



These digital images are
the copyright of
The London Borough of
Barnet 2017

K
L
M
N
O
P
R
S
T
U
V
W
Y

T
C
A
E
C



Borough of Hendon.

NOTICE IS HEREBY GIVEN

That a Special Meeting of the Council of the Borough of Hendon, in the County of Middlesex, will be held on **Monday next, the 17th day of April, 1939**, at **6 o'clock** in the afternoon, at the Town Hall, The Burroughs, Hendon, N.W. 4, and all and several the Members of the said Council are hereby summoned to attend.

The business to be transacted at such meeting is as follows:—

1. To confirm Minutes of the Special Meeting and of the Ordinary Meeting of the Borough Council, held on the 27th March, 1939, and of the Special Meeting held on the 3rd April, 1939.
2. Official Announcements.
3. Mayor's (Easter) Recess Report (*to follow*).
4. To approve, or otherwise, the Report of the Air Raid Precautions Committee (12/4/39—*to follow*).

Town Clerk.

Town Clerk's Office,
Hendon, N.W. 4.
12th April, 1939.

D
E
F
G
H
I
J
K
L
M
N
O
P
Q
R
S
T
U

at

N

A

L

Minutes.

At a Special Meeting of the COUNCIL of the BOROUGH OF HENDON convened pursuant to the provisions of Section 40 of the Local Government Superannuation Act, 1937, held at the Town Hall, The Burroughs, Hendon, N.W 4, on Monday, the 27th day of March, 1939, at 6 o'clock p.m.

PRESENT:

His Worship the Mayor (Councillor H. G. Potter, J.P., F.S.I.), in the Chair.

The Deputy Mayor (Alderman S. H. Egan, J.P.).

Aldermen:

**W. R. Clemens, F.C.A.,
J. J. Copestake, J.P.,**

**B. Flowers,
W. M. Maughan, J.P.,**

**B. J. Monro,
A. J. Reynolds, J.P.,**

Councillors:

**E. Arter, M.C., M.I.A.E.,
F. H. Bate,
F. J. Collins,
E. J. Cox,
A. W. Curton,
A. W. Greville,
C. H. Hignett,
P. Lightfoot,**

**A. A. Naar, M.B.E.,
(Mrs.) F. E. Parvin,
C. Pinkney,
G. J. Pryke, F.I.A.C.,
A.M.I.S.E.,
T. Pugh,
C. R. Richardson,**

**J. H. Rodway,
T. J. Scott,
W. H. N. Shakespeare,
M.C., A.F.C., J.P.,
H. P. Small,
C. F. Windust.**

NOTICE OF MEETING:

The Town Clerk read the Notice convening the meeting.

APOLOGIES FOR ABSENCE:

Apologies for absence were submitted on behalf of Aldermen F. C. Rice and R. A. B. Teare, M.B.E.; Councillors H. Connell, J.P., L. Hirshfield and (Mrs.) M. Thomas.

LOCAL GOVERNMENT SUPERANNUATION ACT, 1937:

Statutory Resolutions. (F. & G.P.C., 20/2/39—14).

Motion moved by Alderman Clemens, seconded by Alderman Copestake, and RESOLVED—

(i) Classification of Servants.

181.—

That all servants falling within the following classifications shall become contributory employees:—

Class A shall consist of

Employees to whom on the 31st March, 1939, the Local Government and Other Officers' Superannuation Act, 1922, applied, and such other employees as satisfy all of the following conditions:—

- (a) Age not to exceed 40 years on the 31st December in the year preceding that in which he is brought into Class A.
- (b) Continuous employment with the Council for not less than 2 consecutive years or who transfer from the service of another Local Authority in such circumstances as will call for the payment of a transfer value to this Council.
- (c) Have been passed medically fit after examination by the Council's Medical Staff.
- (d) Have by specific resolution of the Council been transferred to Class A.

Class B shall consist of

Employees who satisfy all of the following conditions:—

- (a) Whose appointments have been made in the terms of an advertisement inviting applications in which it was stipulated that the person appointed would be required to contribute to the Superannuation Fund.
- (b) Have been passed medically fit after examination by the Council's Medical Staff.
- (c) Have by specific resolution of the Council been included in Class B.

(ii) *Employees of the Managers of Non-Provided Schools.*

182.—

That every Caretaker employed by the Managers of any Public Elementary School maintained but not provided by the Local Education Authority shall be a contributory employee provided such employee satisfies all of the following conditions:—

- (a) Age must not exceed 40 years, provided that in the case of an employee at the 27th March, 1939, the age of such employee must not have exceeded 40 years at the 1st April, 1925, or at the date of entry into the service of the Managers whichever is the later.
- (b) The employment of such employee must be full time employment as School Caretaker on the basis of the normal working day applicable to School Caretakers.
- (c) Such employee shall have been passed medically fit after examination by the Council's Medical Staff.
- (d) Approval to each employee being brought within the scope of the Local Government Superannuation Act, 1937, has been given:—
 - (i) by the appropriate School Managers, and
 - (ii) by a specific resolution passed by the Council on the recommendation of the Education Committee.

Minutes.

At a Monthly Meeting of the COUNCIL of the BOROUGH OF HENDON, held at the Town Hall, The Burroughs, Hendon, N.W.4, on Monday, the 27th day of March, 1939, at 6.10 o'clock p.m.

PRESENT:

His Worship the Mayor (Councillor H. C. Potter, J.P., F.S.I.), *in the Chair.*

The Deputy Mayor (Alderman S. H. Egan, J.P.).

Aldermen:

**W. R. Clemens, F.C.A.,
J. J. Copestake, J.P.,**

**B. Flowers,
W. M. Maughan, J.P.,**

**B. J. Monro,
A. J. Reynolds, J.P.,**

Councillors:

**E. Arter, M.C., M.I.A.E.,
F. H. Bate,
F. J. Collins,
E. J. Cox,
A. W. Curton,
F. W. Gilpin,
A. W. Greville,
W. A. Hicks,**

**G. H. Hignett,
P. Lightfoot,
A. A. Naar, M.B.E.,
(Mrs.) F. E. Parvin,
C. Pinkney,
G. J. Pryke, F.I.A.C.,
A.M.I.S.E.,
T. Pugh,**

**G. R. Richardson,
J. H. Rodway,
T. J. Scott,
W. H. N. Shakespeare,
M.C., A.F.C., J.P.,
H. P. Small,
C. F. Windust.**

NOTICE OF MEETING:

The Town Clerk read the notice convening the Meeting.

MINUTES—CONFIRMATION:

Moved by Councillor Naar, seconded by Alderman Flowers, and

183.—RESOLVED—That the Minutes of the Special Meeting of the Borough Council held on the 20th day of March, 1939, be confirmed.

RESIGNATION OF COUNCILLOR C. B. BAGGS:

The Town Clerk read a letter from Councillor C. B. Baggs tendering his resignation as a Member of the Borough Council and announced that the election to fill the casual vacancy would take place on Tuesday the 25th April, 1939.

QUESTION:

Pursuant to notice duly given in accordance with Standing Order No. 25 Councillor Gilpin asked the Chairman of the Finance and General Purposes Committee (Alderman Clemens) the following question:—

“How many summonses for the non-payment of rates have been issued during each of the last five financial years, and what percentage in each of these years these figures bear to the total number of hereditaments to which rate demands are issued half-yearly?”

Reply by Alderman Clemens:—

The information asked for in the question by Councillor Gilpin is as follows:—

Year ends 31st March.	No. of Summonses.	Percentage to Demands.
1935	4110	8.8
1936	5725	11.8
1937	5675	11.2
1938	6255	12.0
1939	6379	12.0

Alderman Clemens intimated that he was in possession of further figures which he would be pleased to hand to Councillor Gilpin if he so desired.

EDUCATION COMMITTEE:

REPORT NO. 1.

Moved by Alderman Copestake, seconded by Councillor Scott, and

184.—RESOLVED—That Report No. 1 of the Education Committee (Meeting held on the 14th March, 1939—Agenda, pages 458-478) be received.

ADOPTION OF REPORT: Moved by Alderman Copestake, seconded by Councillor Scott, and

185.—RESOLVED—That Report No. 1 of the Committee in so far as it relates to matters requiring the confirmation of the Council be approved and adopted.

REPORT NO. 2.

Moved by Alderman Copestake, seconded by Councillor Gilpin, and

186.—RESOLVED—That Report No. 2 of the Education Committee (Meeting held on the 14th March, 1939—Agenda, pages 479-480) be received.

REPORT NO. 3.

Moved by Alderman Copestake, seconded by Councillor Scott, and

187.—RESOLVED—That Report No. 3 of the Education Committee (Meeting held on the 20th March, 1939—Agenda, pages 481-482) be received.

ADOPTION OF REPORT: Moved by Alderman Copestake, seconded by Councillor Scott, and

188.—RESOLVED—That Report No. 3 of the Committee in so far as it relates to matters requiring the confirmation of the Council be approved and adopted.

REPORT NO. 4.

Moved by Alderman Copestake, seconded by Councillor Scott, and

189.—RESOLVED—That Report No. 4 of the Education Committee (Meeting held on the 21st March, 1939—Agenda, page 483) be received.

PUBLIC HEALTH AND MEDICAL SERVICES COMMITTEE:

Moved by Councillor Scott, seconded by Councillor Bate, and

190.—RESOLVED—That the report of the Public Health and Medical Services Committee (Meeting held on the 6th March, 1939—Agenda, pages 484-490) be received.

ADOPTION OF REPORT: Moved by Councillor Scott, seconded by Alderman Maughan, and

- 191.—RESOLVED—That the report of the Public Health and Medical Services Committee be approved and adopted.

HIGHWAYS COMMITTEE:

Moved by Councillor Curton, seconded by Councillor Windust, and

- 192.—RESOLVED—That the report of the Highways Committee (Meeting held on the 6th March, 1939—Agenda, pages 491-499) be received.

Page 491—Item 2—Standing Orders and Instructions to Committees.

AN AMENDMENT moved by Councillor Collins that the word "become" should be substituted for "remain" in the last line of item 2 of the Committee's Report, was **not seconded**.

ADOPTION OF REPORT: Motion moved Councillor Curton seconded by Councillor Hignett, and

- 193.—RESOLVED—That the report of the Highways Committee be approved and adopted.

ESTATES, PARKS AND ALLOTMENTS COMMITTEE:

Moved by Councillor Collins, seconded by Councillor (Mrs.) Parvin, and

- 194.—RESOLVED—That the report of the Estates, Parks and Allotments Committee (Meeting held on the 6th March, 1939—Agenda, pages 500-506) be received.

Page 500—Item 3—Moat Mount Camp Site.

AMENDMENT moved by Alderman Copestake, seconded by Alderman Flowers:—
THAT the following words be substituted for those appearing in paragraph 1 of the Committee's recommendation hereon:—

"That the Borough Surveyor be instructed to submit a Report to the Chairman of the Committee regarding the provision of an adequate water supply and sanitary accommodation at the Moat Mount Camp Site, and that His Worship the Mayor be authorised to take such action thereon as may be requisite during the Recess."

After discussion, the amendment was submitted and declared **carried**.

SUBSTANTIVE MOTION: Upon submission of the amendment as the substantive motion it was declared **carried**.

- 195.—Accordingly RESOLVED—

- (1) That the Borough Surveyor be instructed to submit a Report to the Chairman of the Committee regarding the provision of an adequate water supply and sanitary accommodation at the Moat Mount Camp Site, and that His Worship the Mayor be authorised to take such action thereon as may be requisite during the Recess.
- (2) That a provisional sum of £500 be included in the Estimates for 1939/40.

*Page 502—Item 10—West Hendon Playing Fields—
Dressing Rooms and Drainage.*

AMENDMENT moved by Alderman Clemens, seconded by Alderman Copestake:—
THAT Recommendation No. 2 be deleted and the following substituted:—

"(2) That application be made to the Minister of Health for sanction to the borrowing of the sum of £5,200 for a period not exceeding 20 years."

On submission, the amendment was declared **carried**.

196.—Accordingly RESOLVED—

- (1) That the plans and estimates amounting to £5,150 be approved.
- (2) That application be made to the Minister of Health for sanction to the borrowing of the sum of £5,250 for a period not exceeding 20 years.

Page 503—Item 11—Clitterhouse Playing Fields—Dressing Room.

AMENDMENT moved by Alderman Clemens, seconded by Councillor Curton:—

THAT Recommendation No. 2 be deleted and the following substituted:—

- “(2) That a nominal rental of £1 per annum be approved subject to the execution of an agreement in form to be approved by the Town Clerk.”

On submission, the amendment was declared **carried**.

197.—Accordingly RESOLVED—

- (1) That the Clitterhouse Community Association (Women's Section) be granted the use of a dressing room in Clitterhouse Playing Fields during one afternoon each week.
- (2) That a nominal rental of £1 per annum be approved subject to the execution of an agreement in form to be approved by the Town Clerk.

Page 505—Item 22—Deans Lane Allotments—Huts.

AMENDMENT (proposed by the Finance and General Purposes Committee) moved by Alderman Clemens, and seconded by Councillor Curton:—

THAT the matter be referred back to enable the Borough Surveyor to report on estimated costs after submission of plans by the Edgware Allotments Society.

After discussion the amendment was submitted and declared **lost**.

ADOPTION OF REPORT: Moved by Councillor Collins, seconded by Councillor Windust, and

198.—RESOLVED—That the report of the Estates, Parks and Allotments Committee, as amended, be approved and adopted.

WORKS AND FIRE BRIGADE COMMITTEE:

Moved by Councillor Naar, seconded by Councillor Greville, and

199.—RESOLVED—That the report of the Works and Fire Brigade Committee (Meeting held on the 13th March, 1939—Agenda, pages 507-515) be received.

Page 509—Item 12—Fire Stations—Open Day.

In reply to a question, the Chairman of the Committee (Councillor Naar) stated that the date on which the Central and Mill Hill Fire Stations would be open for inspection by the public had been fixed for Saturday, the 20th May, from 3 p.m. and that steps would be taken to inform the public.

Page 513—Item 22—Trade Refuse.

AMENDMENT moved by Alderman Clemens, seconded by Councillor Pryke:—

THAT the above matter be referred back for further consideration.

After discussion the amendment was submitted and declared **carried**.

200.—Accordingly RESOLVED—That item 22 of the report of the Works and Fire Brigade Committee be referred back for further consideration.

ADOPTION OF REPORT: Moved by Councillor Naar, duly seconded, and
 201.—RESOLVED—That the report of the Works and Fire Brigade Committee, as amended, be approved and adopted.

LIBRARIES AND LOCAL PENSIONS COMMITTEE:

Moved by Councillor Lightfoot, seconded by Councillor Curton, and
 202.—RESOLVED—That the report of the Libraries and Local Pensions Committee (Meeting held on the 13th March, 1939—Agenda, pages 516-517) be received.

ADOPTION OF REPORT: Moved by Councillor Lightfoot, seconded by Councillor Scott, and
 203.—RESOLVED—That the report of the Libraries and Local Pensions Committee be approved and adopted.

HOUSING COMMITTEE:

Moved by Councillor Gilpin, seconded by Councillor Scott, and
 204.—RESOLVED—That the report of the Housing Committee (Meeting held on the 13th March, 1939—Agenda, pages 518-522) be received.

Pages 520-521—Item 10—Repairs on Municipal Housing Estates.

AMENDMENT moved by Councillor Curton, seconded by Councillor Scott:—
 THAT £7 be substituted for £5 in paragraph 2 of the Committee's recommendation hereon.

After discussion the amendment was submitted and declared **lost**.

Page 522—Item 15—National Housing and Town Planning Council.

On consideration of the above item, amendment moved by Alderman Clemens, seconded by Alderman Copestake:—

THAT the words "Chairman (Councillor F. W. Gilpin) and Councillor G. J. Pryke" be deleted and the following substituted:—

"One representative to be selected from the two nominations before the Committee and the Housing Manager."

The amendment, on submission, was declared **carried**.

Arising out of the adoption of the foregoing amendment, Councillor Gilpin intimated that Councillor G. J. Pryke and the Housing Manager would attend the Conference.

205.—Accordingly RESOLVED—That Councillor G. J. Pryke and the Housing Manager be appointed as the Council's delegates to the Annual Conference of the National Housing and Town Planning Council to be held in London on Tuesday the 6th June, 1939.

ADOPTION OF REPORT: Moved by Councillor Gilpin, seconded by Councillor Scott, and

206.—RESOLVED—That the report of the Housing Committee, as amended, be approved and adopted.

BUILDINGS AND TOWN PLANNING COMMITTEE:

Moved by Councillor Hignett, seconded by Councillor Small, and

- 207.—RESOLVED—That the report of the Buildings and Town Planning Committee (Meeting held on the 13th March, 1939—Agenda, pages 523-535) be received.

Declaration of Interest.

Before consideration of the report the Deputy Mayor (Alderman S. H. Egan, J.P.) intimated that as he was interested in St. Vincent's (Building Application No. A.7976) he would abstain from taking part in the proceedings in so far as the consideration of the report of the Committee was concerned.

Page 526—Item 12—National Housing and Town Planning Council.

On consideration of the above item, amendment moved by Alderman Clemens, seconded by Alderman Reynolds:—

THAT the words "Chairman (Councillor G. H. Hignett), Alderman S. H. Egan, and the Borough Surveyor" be deleted and the following substituted:—

"Two representatives to be selected from the nominations before the Committee."

On submission, the amendment was declared **carried**.

The Chairman of the Committee (Councillor G. H. Hignett) intimated that Alderman Egan and the Borough Surveyor would attend the Conference.

- 208.—Accordingly RESOLVED—That Alderman S. H. Egan, J.P., and the Borough Surveyor be appointed to attend the Annual Conference of Local Authorities in London and the Home Counties to be held at the County Hall, Westminster Bridge, on Tuesday, the 6th June, 1939, and that the annual subscription of £5 5s. 0d. be paid.

Page 535—Item 18—Cranmer Road and Lynford Gardens, Edgware.

AMENDMENT moved by Councillor Curton, seconded by Councillor Gilpin:—

THAT the above matter be referred back for further consideration.

After hearing a statement by the Chairman of the Committee, the amendment was submitted and declared **lost**.

ADOPTION OF REPORT: Moved by Councillor Hignett, duly seconded, and

- 209.—RESOLVED—That the report of the Committee, as amended, be approved and adopted.

RATING AND VALUATION COMMITTEE:

Moved by Councillor Small, seconded by Councillor Windust, and

- 210.—RESOLVED—That the report of the Rating and Valuation Committee (Meeting held on the 22nd March, 1939—Agenda, page 536) be received.

AIR RAID PRECAUTIONS COMMITTEE:

Moved by Councillor Arter, seconded by Councillor Windust, and

- 211.—RESOLVED—That the report of the Air Raid Precautions Committee (Meeting held on the 8th March, 1939—Agenda, pages 537-544) be received.

Page 538—Item 2—Trenches.

AMENDMENT moved by Councillor Curton, seconded by Alderman Copestake:—
THAT the following addition be made to the Committee's recommendation hereon:—

“ That the Council shall immediately place an order for sufficient steelwork to a pattern or patterns approved by the Home Office from at least two firms to enable the Council to complete the Trenches already commenced in the Borough at the earliest possible moment, and that the Council proceed to complete these Trenches as early as possible.”

After discussion, the amendment was submitted and declared **carried**.

SUBSTANTIVE MOTION: Upon submission of the amendment as the Substantive Motion, it was declared **carried**.

212.—Accordingly RESOLVED—

- (1) That the Borough Surveyor be authorised to proceed with the completion of the Trenches at the Isolation Hospital on the lines contemplated.
- (2) That the Council immediately place an order for sufficient steelwork to a pattern or patterns approved by the Home Office from at least two firms to enable the Council to complete the Trenches already commenced in the Borough at the earliest possible moment, and that the Council proceed to complete these Trenches as early as possible.

ADOPTION OF REPORT: Moved by Councillor Arter, seconded by Councillor Curton, and

213.—RESOLVED—That the report of the Air Raid Precautions Committee, as amended, be approved and adopted.

FINANCE AND GENERAL PURPOSES COMMITTEE:

Moved by Alderman Clemens, duly seconded, and

214.—RESOLVED—That the report of the Finance and General Purposes Committee (Meeting held on the 20th March, 1939—Agenda, pages 545-594) be received.

Page 545—Item 2—Estimates, 1939/40.

On consideration of the above item, the Chairman of the Committee (Alderman Clemens) dealt with numerous items of income and expenditure for which provision had been made in the estimates.

Moved by Alderman Clemens, and duly seconded:—

THAT recommendation 2 (2) of the Committee's Report be approved and adopted.

Debate ensued.

AMENDMENT moved by Councillor Richardson, seconded by Councillor Rodway:—

THAT the following words be inserted after the word “ approved ” in the second line of paragraph 1 of the Committee's recommendation:—

“ subject to the reinstatement of the sum of £1,000 for the provision of modern equipment in the children's playing grounds in the parks and open spaces.”

Debate ensued.

The amendment, on being submitted, was declared **lost**, whereupon a Division was demanded by Councillor Pinkney and two other members and taken with the following result:—

For 10.	Against 11.	Abstained from Voting 4.	Absent when Division taken 10.
Alderman Maughan.	The Deputy Mayor.	The Mayor.	Alderman Monro.
Councillor Bate.	Alderman Copestake.	Alderman Clemens.	" Rice.
" Collins.	" Flowers.	Councillor Hicks.	" Teare.
" Cox.	" Reynolds.	" Windust.	Councillor Connell.
" (Mrs.) Parvin.	Councillor Arter.		" Griffiths.
" Pinkney.	" Curton.		" Hignett.
" Pryke.	" Gilpin.		" Harshfield.
" Pugh.	" Greville.		" Scott.
" Richardson.	" Lightfoot.		" Shakespeare.
" Rodway.	" Naar.		" (Mrs.) Thomas.
	" Small.		

The Mayor declared the amendment **lost**.

215.—Accordingly **RESOLVED**—

(2) That the General Rate of 11/- in the £ be approved for the year ending 31st March, 1940, payable by two equal half-yearly instalments on the Rateable Value of each hereditament in the Borough, and that the Borough Treasurer be authorised to prepare such Rate with a view to the said Rate being made and sealed at a Special Meeting of the Council to be held on Monday, 3rd April next.

Page 559—Item 50—Standing Orders and Instructions to Committees.

AMENDMENT moved by Alderman Reynolds, seconded by Alderman Maughan:—

THAT the proposed Standing Orders from paragraph 8 (Standing Committees) on page 571 to the end, be referred back and that the Finance and General Purposes Committee be instructed to consider the advisability of:—

- (i) The Mayor being an ex-officio Member of all Committees, and
- (ii) The Chairmen of Committees being appointed by the Council.

Discussion ensued, upon which the Chairman of the Committee intimated that he had no objection to the Standing Orders being referred back for further consideration in the light of the terms of the amendment proposed.

The Council having indicated their assent, it was

216.—**RESOLVED accordingly.**

(In reply to a question, the Chairman of the Finance and General Purposes Committee intimated that the attendance and views of Members of the Council would be welcomed when the matter was under consideration.)

ADOPTION OF REPORT: Moved by Alderman Clemens, duly seconded, and

217.—**RESOLVED—That the report of the Finance and General Purposes Committee, as amended, be approved and adopted.**

EDGWARE—FINANCIAL ADJUSTMENT:

218.—**RESOLVED—That the report of the Borough Treasurer on the above matter be considered by the Council in Committee this evening.**

EASTER RECESS:

Moved by the Deputy Mayor (Alderman S. H. Egan), seconded by Alderman Reynolds, and

219.—RESOLVED—That His Worship the Mayor, or in his absence the Deputy Mayor, be vested with power to deal with any urgent matters which may arise during the Easter Vacation, i.e., 28th March to the 17th April.

ADJOURNMENT:

At 8.25 p.m. on the motion of the Mayor the Council adjourned to 8.35 this day to be resumed in Committee.

Herbert P. Potters
Mayor.

Council in Committee

27th March, 1939.

PRESENT:

His Worship the Mayor (Councillor H. C. Potter, J.P., F.S.I.), *in the Chair.*

The Deputy Mayor (Alderman S. H. Egan, J.P.).

Aldermen:

J. J. Copestake, J.P.,
B. Flowers,

W. M. Maughan, J.P.,

A. J. Reynolds, J.P.,

Councillors:

E. Arter, M.C., M.I.A.E.,
F. H. Bate,
F. J. Collins,
E. J. Cox,
A. W. Curton,
F. W. Gilpin,

A. W. Greville,
G. H. Hignett,
A. A. Naar, M.B.E.,
(Mrs.) F. E. Parvin,
C. Pinkney,

G. J. Pryke, F.I.A.C.,
A.M.I.S.E.,
T. Pugh,
J. H. Rodway,
H. P. Small,
C. F. Windust.

EDGWARE—FINANCIAL ADJUSTMENT:

Hendon Urban District Council Act, 1929.

The Borough Treasurer reported that further negotiations had taken place on the above matter and that it was now recommended that the Town Council should approve the payment of the sum of £25,000 in full settlement of the claims of the Harrow Urban District Council in respect of the severance of the Parish of Edgware from the late Hendon Rural District. The claim originally made in 1932, including interest, amounted to £100,451.

220.—RESOLVED—

- (1) That approval be given to the payment of the sum of £25,000 to the Harrow Urban District Council (successors to the Hendon Rural District Council) in full settlement of the claim in respect of the transfer, under Part II., of the Hendon Urban District Council Act, 1929, of the Parish of Edgware to the Hendon Urban District on the 1st April, 1931.
- (2) That the Borough Treasurer be authorised to borrow under Section 153 of the Act, 1929, the sum of £25,000 for the purpose of making the payment to the Harrow Urban District Council.

The Meeting terminated at 8.39 p.m.

Herbert Potter
Mayor.



Borough of Hendon.

NOTICE IS HEREBY GIVEN

That a Special Meeting of the Council of the Borough of Hendon, in the County of Middlesex, will be held on **Monday** next, the **3rd** day of **April, 1939**, at **6** o'clock in the afternoon, at the Town Hall, The Burroughs, Hendon, N.W. 4, and all and several the Members of the said Council are hereby summoned to attend.

The business to be transacted at such meeting is as follows:—

1. Official Announcements.
2. General Rate—Year ending 31st March, 1940:—

To RESOLVE—That the Council make a General Rate of 11/- in the pound (payable in two equal half yearly instalments) to meet the expenses of the Council for the year ending 31st March, 1940, and that the Corporate Seal be affixed thereto.

G. W. W. W.

Town Clerk.

Town Clerk's Office,
Hendon, N.W. 4.
29th March, 1939.

P
E
R
T
H
O
L
K
L
M
N
O
P
O
R
S

at

NOT

APC

GEN

Minutes.

At a Special Meeting of the COUNCIL of the BOROUGH OF HENDON, held at the Town Hall, The Burroughs, Hendon, N.W. 4, on Monday, the 3rd day of April, 1939, at 6 o'clock p.m.

PRESENT:

His Worship the Mayor (Councillor H. G. Potter, J.P., F.S.I.), in the Chair.

The Deputy Mayor (Alderman S. H. Egan, J.P.).

Aldermen:

**W. R. Clemens, F.C.A.,
J. J. Copestake, J.P.,**

**W. M. Maughan, J.P.,
A. J. Reynolds, J.P.,**

F. C. Rice.

Councillors:

**F. H. Bate,
F. J. Collins,
H. Connell, J.P.,
E. J. Cox,
A. W. Curton,
F. W. Gilpin,
A. W. Creville,
J. Griffiths,**

**C. H. Hignett,
A. A. Naar, M.B.E.,
(Mrs.) F. E. Parvin,
C. Pinkney,
G. J. Pryke, F.I.A.C.,
A.M.I.S.E.,
T. Pugh,**

**C. R. Richardson,
J. H. Rodway,
T. J. Scott,
W. H. N. Shakespeare,
M.C., A.F.C., J.P.,
H. P. Small,
C. F. Windust.**

NOTICE OF MEETING:

The Town Clerk read the notice convening the meeting.

APOLOGIES FOR ABSENCE:

Apologies for absence were submitted on behalf of Alderman B. J. Monro and Alderman R. A. B. Teare, M.B.E.

GENERAL RATE—YEAR ENDING 31st MARCH, 1940:

Motion moved by Alderman Clemens (Chairman of the Finance and General Purposes Committee), seconded by Alderman Reynolds:—

THAT the Council make a General Rate of 11/- in the pound (payable in two equal half yearly instalments) to meet the expenses of the Council for the year ending 31st March, 1940, and that the Corporate Seal be affixed thereto.

Alderman Clemens submitted an explanatory statement on the rate estimates and gave details of the Middlesex County Council's Rate Precept and details of their financial policy, and also paid a tribute to the Borough Treasurer and his Staff on the excellent manner in which the estimates and accompanying statistics had been prepared.

Debate ensued.

The motion, on being submitted, was declared **carried**.

221.—Accordingly **RESOLVED**—That the Council make a General Rate of 11/- in the pound (payable in two equal half yearly instalments) to meet the expenses of the Council for the year ending 31st March, 1940, and that the Corporate Seal be affixed thereto.

The meeting terminated at 7.18 p.m.

James G. Potter

P
E
G
H
C
K
L
M
N
O
P
Q
R
S
T



At

M

Bo

51



Borough of Hendon

.....

ESTIMATE FOR GENERAL RATE

1939 - 1940

At a Meeting of the Council held 27th March, 1939.

Moved by Alderman W. R. Clemens, F.C.A., J.P., seconded, and

RESOLVED—That the General Rate of 11/0d. in the £ be approved for the year ending 31st March, 1940, payable by two equal half-yearly instalments, on the rateable value of each hereditament in the Borough, and that the Borough Treasurer be authorised to prepare such rate with a view to the said rate being made and sealed at a Special Meeting of the Council to be held on Monday, the 3rd April, 1939.

Borough Treasurer's Department,
Town Hall,
Hendon, N.W. 4.

31st March, 1939.

D
E
F
G
H
I
K
L
M
N
O
P
Q
R
S
T

Bu
Pu
Wo
Est
Pu
Hig
Air
Fin
Ed
Sun
Pre
Det
App

CONTENTS.

General Rate Estimates, 1939-40.

	Outlay Page	Income Page	Notes
Buildings and Town Planning Committee ...	1	1	1
Public Libraries Committee	2	3	3
Works & Fire Brigade Committee ...	4-10	11-13	14-15
Estates, Parks & Allotments Committee ...	16-30	31-35	36-40
Public Health & Medical Services Committee	41-45	46-47	48-49
Highways Committee	50-56	57	58-61
Air Raid Precautions	62	62	62
Finance & General Purposes Committee ...	63-65	66-68	69-70
Education Committee	71-83	71-83	71-83
Summary—All Committees	84-85	84-85	—
Precepts from Other Authorities ...	—	—	86
Details of Gross Requirements and Provision	—	—	87
Appendix (see Detailed Index on Page 88)	—	—	88-114

P
R
E
S
E
N
T
A
B
S
E
N
C
E
O
F
T
H
E
C
O
U
N
C
I
L
O
F
T
H
E
C
O
U
N
T
Y
O
F
S
U
S
S
E
X

Outline
1987/88
£

500

7

81

51

67

1

14

370

78

1079

63

£1016

BUILDINGS AND TOWN PLANNING COMMITTEE

ESTIMATES OF EXPENDITURE, 1939/40.

Outlay 1937/38. £	Item.	Expenditure.	Approved Estimate 1938/39. £	Approx. Outlay 1938/39. £	Estimate for 1939/40. £
TOWN PLANNING.					
500	1	Salaries	552	568	572
7	2	Wages	8	4	6
31	3	Superannuation Contributions	29	28	29
51	4	Statutory Notices, Advertising and Postages	60	36	60
—	5	Printing Scheme and Lithography	75	216	30
67	6	Maps, Map Mounting, Plans, Printing and Stationery	75	60	50
1	7	Travelling Expenses and Sundries	5	3	5
14	8	Conference Expenses	20	19	20
370	9	Inquiry Fees and Costs	—	6	—
—	10	Contingent Item (Compensation)	250	—	250
78	11	Contribution—North Middlesex Com- mittee	—	—	—
1079			1074	940	1022
Income:—					
63	12	Sale of Scheme and Maps, and Fees for Advertisements	74	44	52
£1016		Balance—Rate Charge	£1000	£896	£970

MEMORANDA.

The nett Rate Charge shows a **decrease** of £30 (£1,000, less £970) and is made up as follows:—

	£
Wages	2
Printing Scheme and Lithography	45
Maps, Plans, Printing and Stationery	25
	72
Less:—	
Increase—Salaries (Scale Increments)	20
	52
Deduct:—	
Estimated Decrease in Income	22
	£30

PUBLIC LIBRARIES COMMITTEE

ESTIMATES OF EXPENDITURE, 1939/40.

Item.	Central Library.			Golders Green (Branch) Library.			Mill Hill (Branch) Library.*			Summary of Outlay.		
	Approved Approx. Proposed Outlay Estimate Outlay Figures 1937/38, 1938/39, 1938/39, 1939/40.			Approved Approx. Proposed Outlay Estimate Outlay Figures 1937/38, 1938/39, 1938/39, 1939/40.			Approved Approx. Proposed Outlay Estimate Outlay Figures 1937/38, 1938/39, 1938/39, 1939/40.			Approved Approx. Proposed Outlay Estimate Outlay Figures 1937/38, 1938/39, 1938/39, 1939/40.		
	£	£	£	£	£	£	£	£	£	£	£	£
13 Books, Binding and Numbering	2087	2100	2150	1397	1500	1625	1986	1550	1500	5470	5150	5275
14 Books	205	220	214	81	73	75	38	71	75	354	364	378
15 Papers and Periodicals	237	200	197	156	130	125	191	117	106	584	447	428
16 Printing, Stationery and Office Equipment	78	40	37	26	10	27	9	10	5	113	60	69
17 Furniture and Fittings	224	200	197	103	90	93	34	71	73	361	361	363
18 Postages and Travelling Expenses	3602	4100	4063	1081	1170	1158	875	1268	1190	5558	6338	6411
19 Salaries	226	255	250	79	82	78	51	78	79	356	415	407
20 Superannuation and National Insurance	31	32	36	25	28	28	15	28	28	71	88	92
21 Telephone Service	401	400	426	164	165	175	16	160	208	581	725	809
22 Rates and Insurance	34	35	34	13	15	13	2	15	4	49	65	51
23 Water	92	130	98	43	65	45	17	35	48	152	230	191
24 Repairs and Upkeep of Buildings	352	363	370	148	172	166	150	231	209	650	766	745
25 Heating, Lighting and Cleaning	563	580	574	253	264	265	139	281	289	935	1125	1128
26 Wages of Caretakers and Assistants (including Uniforms)	46	100	100	36	36	36	17	60	60	99	196	196
27 Renewals Fund (Heating Plant)	8178	8755	8696	3605	3800	3784	3540	3975	3924	15323	16539	16404
28 Opening Ceremony	—	—	—	—	—	—	41	—	—	41	—	—
29 Special Painting and Re-decoration	88	125	56	—	20	—	—	—	—	88	145	56
30	£8266	£8880	£8752	£3605	£3820	£3784	£3681	£3975	£3924	£15452	£16675	£16460
			£9124			£4310			£4113			£17547

* The Mill Hill (Branch) Library Estimates are based on a full year's requirements for 1938/39 and 1939/40 as compared with part year for 1937/38.

Income 1937/38.

£	497
£	39
£	536
£	415
£	123
£	33
£	1107

No.

1	1	1
2	2	2
3	3	3

PUBLIC LIBRARIES COMMITTEE

ESTIMATES OF INCOME, 1939/40.

Income 1937/38. £	Item.	Income.	Approved Estimate 1938/39. £	Approx. Income 1938/39. £	Estimate for 1939/40. £
CENTRAL LIBRARY.					
497	29	Sundry Fines and Fees	500	563	575
39	30	Rent—Caretaker's Quarters	40	40	40
536			540	603	615
GOLDERS GREEN (BRANCH) LIBRARY.					
415	31	Sundry Fines and Fees	350	521	550
MILL HILL (BRANCH) LIBRARY.					
123	32	Sundry Fines and Fees	250	300	300
33	33	Heating Service—Clinic	100	100	100
£1107			£1240	£1524	£1565

SUMMARY OF EXPENDITURE AND INCOME.

EXPENDITURE.	Actual.	Estimate.	Approx.	Estimate.
	1937/38	1938/39	1938/39	1939/40
	£	£	£	£
Central Library	8266	8880	8752	9124
Golders Green (Branch) Library	3605	3820	3784	4310
Mill Hill (Branch) Library	3581	3975	3924	4113
	£15452	£16675	£16460	£17547
INCOME.				
Central Library	536	540	603	615
Golders Green (Branch) Library	415	350	521	550
Mill Hill (Branch) Library	156	350	400	400
	£1107	£1240	£1524	£1565
Balance—Rate Charge	£14345	£15435	£14936	£15982

NOTES ON ESTIMATES, 1939/40.

No.	DETAILS.	Comparison 1939/40 Estimates with 1938/39 Results.					
		Outlay.		Income.		Rate Charge.	
		Decrease.	Increase.	Decrease.	Increase.	Decrease.	Increase.
		£	£	£	£	£	£
1	Central Library	—	372	—	12	—	360
2	Golders Green (Branch) Library	—	526	—	20	—	497
3	Mill Hill (Branch) Library	—	189	—	—	—	189
		—	£1087	—	£41	—	£1046

MEMORANDA.

- 1 **Central Library.**—
Increase mainly due to additional staff, and scale increments for existing staff.
- 2 **Golders Green (Branch) Library.**—
Provision made for re-decoration work, and increased allowance for books.
- 3 **Mill Hill (Branch) Library.**—
Sundry minor increases.

WORKS AND FIRE BRIGADE COMMITTEE

ESTIMATES OF EXPENDITURE, 1939/40.

Outlay 1937/38. £	Item.	Expenditure.	Approved Estimate 1938/39. £	Approx. Outlay 1938/39. £	Estimate for 1939/40. £
PUBLIC DEPOT (HENDON WAY).					
1161	34	Wages—Handling Stores	1189	1192	1196
130	35	Wages—Yard and Buildings	65	42	60
79	36	Materials—Repairs	60	26	50
45	37	Fuel and Cleaning Sundries	70	55	60
7	38	Council's Team Labour	9	2	5
6	39	Hired Lorries and Team Labour	6	6	6
148	40	Rent, Rates, Taxes and Insurance	150	363	365
40	41	Telephone Service	44	36	36
49	42	Water and Electricity	55	69	70
13	43	Upkeep of Weighbridge	17	17	17
8	44	Sundries	15	23	20
1686			1680	1831	1885
128	45	Fencing	—	27	—
—	46	Sawing Machine, Lathe, etc.	175	90	—
£1814			£1855	£1948	£1885
PUBLIC DEPOT (MILL HILL).					
541	47	Wages—Handling Stores	494	590	502
—	48	Wages—Yard and Buildings	10	3	5
—	49	Materials—Repairs	10	4	5
—	50	Fuel and Cleaning Sundries	10	26	30
—	51	Hired Lorries and Team Labour	5	2	4
—	52	Rent, Rates, Taxes and Insurance	5	71	125
15	53	Telephone Service	16	20	20
2	54	Water and Electricity	10	14	30
—	55	Upkeep of Weighbridge	6	6	20
3	56	Sundries	3	2	3
£561			£569	£738	£744
GOLDERS GREEN DEPOT.					
£37	57	Rent, Rates, etc.	£38	£38	£38
COUNCIL'S COTTAGES:—					
(a) "Ladore," Hendon Way (Vollar).					
(b) Flat—Clitterhouse Farm (Stevens, W.).					
(c) Flat—Clitterhouse Farm (Smith).					
(d) Cottage—Clitterhouse Farm (Buckingham).					
(e) Brent Farm No. 1 (Reader).					
(f) Brent Farm No. 3 (Stevens, C.).					
(g) Brent Farm No. 5 (Sooby).					
(h) Bungalow—Clitterhouse Lane (Palin).					
(i) Bungalow—Central Depôt (Street).					
(j) Bungalow—Central Depôt (Saxby).					
(k) House—Mill Hill Depôt (Godding).					
(l) House—Mill Hill Depôt (Smith).					
33	58	Wages	89	61	75
17	59	Materials	60	50	55
68	60	Rates and Insurance	90	147	147
7	61	Telephone Service	6	17	17
8	62	Water and Sundries	12	16	15
10	63	Water Heater	—	—	—
£143			£257	£291	£309

Outlay
1937/38.
£

2383

246

44

371

22

5

79

252

136

39

39

45

—

569

56

4286

—

5

30

4

162

—

150

20

3

66

—

4664

—

72

£4736

—

—

—

271

175

77

—

—

10

1

—

—

—

£534

WORKS AND FIRE BRIGADE COMMITTEE (Contd.).

Outlay 1937/38. £	Item.	Expenditure.	Approved Estimate 1938/39. £	Approx. Outlay 1938/39. £	Estimate for 1939/40. £
SEWERS, ETC.					
2383	64	Wages—Cleansing and Maintenance	2763	2440	2750
246	65	Materials—Repairs and Re-building Manholes	250	167	225
44	66	Hired Lorries and Team Labour	40	40	40
371	67	Work done by Council's Lorry	392	329	375
22	68	Water	25	25	25
5	69	Disinfectants	5	5	5
79	70	Tools and Plant	50	67	75
252	71	Drainage of Boundary Property	155	400	400
136	72	Work by Sewer Flushing Vehicle	177	157	157
39	73	Rent of Offices, etc., at Depôt	39	39	39
39	74	Contract Work	30	25	30
45	75	Sundries	30	30	30
—	75a	Telephone Service (Superintendent)	—	7	10
569	76	Upkeep of Lands	250	447	300
56	77	Rain Gauges and Fencing	10	—	—
<u>4286</u>			<u>4216</u>	<u>4178</u>	<u>4461</u>
Sewer Extensions, etc.					
162	78	Barnet Road Sewerage	—	—	—
—	79	Painting Vent Columns	150	93	25
150	80	Watercourse—Ranelagh Drive	—	—	—
—	81	Overflows—Silk Valley Sewer	720	586	—
66	82	Piping-in Stream—Oakhampton Road.....	—	—	—
—	82a	Watercourse—Claremont Road	—	—	170
<u>4664</u>			<u>5086</u>	<u>4857</u>	<u>4656</u>
—	83	Purchase of Gauging Apparatus	75	—	75
72	84	Purchase of Motor Pump	25	—	25
<u>£4736</u>			<u>£5186</u>	<u>£4857</u>	<u>£4756</u>
EMPTYING CESSPOOLS.					
271	85	Wages	261	265	270
175	86	Team Labour	150	162	60
77	87	Maintenance and Depreciation of Cesspool Machine	70	70	15
10	88	Contract Work	10	10	10
1	89	Disinfectants and Sundries	5	2	5
—	90	Work by Cesspool Emptier	—	—	250
—	91	Purchase of Cesspool Emptier (Rate Charge) (Balance)	—	—	450
<u>£534</u>			<u>£496</u>	<u>£509</u>	<u>£1060</u>

WORKS AND FIRE BRIGADE COMMITTEE (Contd.).

Outlay 1937/38. £	Item.	Expenditure.	Approved Estimate 1938/39. £	Approx. Outlay 1938/39. £	Estimate for 1939/40. £	Outlay 1937/38. £
HOUSE REFUSE REMOVAL.						
9565	92	Wages and Salaries	10534	10711	11562	506
603	93	Hired Lorries and Pagefields	559	708	512	4
1103	94	Hired Team Labour	1222	1330	1385	36
3090	95	Council's Team Labour	3070	3298	3273	1
5550	96	Work done by Pagefield Lorries and Containers	5951	5844	6069	70
408	97	Work done by Council's Morris Van	112	325	—	18
—	98	Dustmen's and Drivers' Coats	25	—	120	64
23	99	Baskets, Shovels and Ladders	20	—	25	48
62	100	Disinfectants	75	41	60	37
50	101	Car Allowance—Inspector	50	50	50	61
—	102	Sundries	5	—	5	54
£20454			£21623	£22307	£23091	9
						9
						—
						£926
REFUSE DESTROYER WORKS.						
6577	103	Wages and Salaries	6997	6921	6768	1069
175	104	Repairs to Buildings, Machinery, Plant and Tools	200	257	225	229
1127	105	Plant and Machinery—Upkeep	800	800	1127	129
2	106	Hired Lorries and Team Labour	10	3	5	20
168	107	Water and Electricity	180	160	165	135
18	108	Oil, Waste and Fuel	25	40	35	70
68	109	Rent of Site	68	68	68	118
1140	110	Rates and Insurance	800	864	878	78
5	111	Destruction of Rats	10	10	10	78
14	112	Telephone Service	15	15	15	114
98	113	Upkeep of Tractors	90	80	90	28
12	114	Upkeep of Weighbridge	12	12	12	8
108	115	Construction of Roadways	850	631	—	10
9	116	Sundries	10	21	15	24
9521			10067	9882	9413	—
1421	117	Clinker Crushing Plant (Erection)	266	368	—	£2110
—	117a	Purchase of Mechanical Shovel	—	—	475	—
£10942			£10333	£10250	£9888	420
						3
						4
						44
						67
						26
						120
						107
						10
						52
						6
						12
						£871
HAYMAKING AND GRASS CUTTING.						
598	118	Wages	532	208	205	—
374	119	Council's Team Labour	380	172	175	—
47	120	Sundries	20	18	15	—
£1019			£932	£398	£395	—

WORKS AND FIRE BRIGADE COMMITTEE (Contd.).

Outlay 1937/38. £	Item.	Expenditure.	Approved Estimate 1938/39. £	Approx. Outlay 1938/39. £	Estimate for 1939/40. £
OPEN AIR BATH (WEST HENDON).					
506	121	Wages—Attendants	783	793	825
4	122	Wages—Repairs and Upkeep of Premises	20	45	25
36	123	Materials, etc.—Repairs and Upkeep of Premises	20	28	25
1	124	Upkeep of Filtration and Heating Plant	25	2	20
70	125	Renewals Fund (Plant)	125	136	136
18	126	Towels, Costumes and Laundry	50	35	40
64	127	Chemicals and Cleaning Sundries	105	100	100
48	128	Furniture, Apparatus and Equipment	30	53	45
37	129	Water Supply	75	70	75
61	130	Gas, Electricity and Fuel	193	246	243
54	131	Rents, Rates, Taxes and Insurances	140	190	190
9	132	Printing, Stationery and Advertising	20	15	15
9	133	Telephone Service	10	10	10
9	134	Sundries	6	4	5
—	135	Re-decoration Work	—	25	25
£926			£1602	£1752	£1779
OPEN AIR BATH (MILL HILL).					
1069	136	Wages—Attendants	1026	1027	1080
229	137	Wages—Repairs and Upkeep of Premises	155	167	125
129	138	Materials, etc.—Repairs and Upkeep of Premises	125	138	120
20	139	Upkeep of Filtration, etc., Plant	40	15	30
135	140	Renewals Fund (Plant)	135	135	135
70	141	Towels, Costumes and Laundry	90	63	80
118	142	Chemicals and Cleaning Sundries	135	119	125
78	143	Furniture, Apparatus and Equipment	75	42	60
78	144	Water Supply	105	71	95
114	145	Gas and Electricity	120	93	195
28	146	Insurances	30	33	33
8	147	Printing, Stationery and Advertising	20	10	10
10	148	Telephone Service	10	12	12
24	149	Sundries	10	8	10
£2110			£2076	£1933	£2020
SLIPPER BATHS—WEST HENDON.					
420	150	Wages—Attendants	433	418	432
3	151	Wages—Repairs	15	14	15
4	152	Materials—Repairs	15	14	15
44	153	Electricity and Water	40	42	40
67	154	Fuel	65	81	75
26	155	Soap, Soda and Cleaning Utensils	26	25	25
120	156	Towels	118	111	116
107	157	Rates, Taxes and Insurances	105	111	111
10	158	Rent of Site	10	10	10
52	159	Renewals Fund (Plant)	52	52	52
6	160	Sundries	6	4	5
12	161	Neon Signs	—	—	—
£871			£885	£882	£896

WORKS AND FIRE BRIGADE COMMITTEE (Contd.).

Outlay 1937/38. £	Item.	Expenditure.	Approved Estimate 1938/39. £	Approx. Outlay 1938/39. £	Estimate for 1939/40. £	Outlay 1937/38. £
SLIPPER BATHS—CHILD'S HILL.						
406	162	Wages—Attendants	413	404	420	650
17	163	Wages—Repairs	35	20	25	18
8	164	Materials—Repairs	30	17	20	1426
23	165	Electricity and Water	25	23	25	256
68	166	Fuel	66	63	65	565
10	167	Soap, Soda and Cleaning Utensils	15	15	15	87
60	168	Towels	65	59	60	49
92	169	Rates, Taxes and Insurances	90	95	95	55
48	170	Renewals Fund (Plant)	48	48	48	16
6	171	Sundries	6	4	5	
12	172	Neon Signs	—	—	—	
£750			£793	£748	£778	£3122
PUBLIC CONVENIENCES.						
5692	173	(See details on page 10)	6330	6278	6305	188
—	174	Purchase of Site—Temple Fortune	280	—	280	244
£5692			£6610	£6278	£6585	213
FIRE BRIGADE (CENTRAL STATION).						
2763	175	Salaries and Wages (including Super- annuation)	2869	3624	4830	160
333	176	Rents of Quarters	345	402	430	412
124	177	Uniforms and Boots	88	217	170	531
141	178	Appliances, Hose, Tools, etc.	105	112	120	543
1	179	Upkeep of Buildings—Wages	5	10	10	301
30	180	Upkeep of Buildings—Materials	30	52	40	211
13	181	Electrical Fittings and Repairs	5	19	10	77
239	182	Fuel, Light and Water	215	256	265	£2880
23	183	Furnishings	25	211	25	
60	184	Cleaning Sundries	32	35	45	
7	185	Carriage and Travelling Expenses	13	30	15	
262	186	Rent, Rates, Taxes and Insurance	258	285	298	
—	187	Special Repairs and Alterations to Buildings and Yard—Shower Baths, etc.	—	115	—	1814
£3996			£3990	£5368	£6258	561
FIRE BRIGADE (MILL HILL STATION).						
3767	188	Salaries and Wages (including Super- annuation)	3725	4024	4245	37
748	189	Rents of Quarters	748	748	748	2412
128	190	Uniforms and Boots	124	139	145	143
28	191	Appliances, Hose, Tools, etc.	40	84	50	4730
1	192	Upkeep of Buildings—Wages	5	2	5	534
20	193	Upkeep of Buildings—Materials	25	45	25	29454
10	194	Electrical Fittings and Repairs	8	10	10	10942
179	195	Fuel, Light and Water	190	191	195	1619
—	196	Furnishings	—	1	5	926
26	197	Cleaning Sundries	18	21	20	2110
2	198	Carriage and Travelling Expenses	7	1	5	871
412	199	Rates, Taxes and Insurance	406	423	423	750
57	200	Rent of Site—Station and Cottages	57	57	57	5692
—	201	Smoke Test Chamber	—	235	—	2996
£5378			£5353	£5981	£5933	5378
						3122
						2880
						£65965

WORKS AND FIRE BRIGADE COMMITTEE (Contd.).

Outlay 1937/38. £	Item.	Expenditure.	Approved Estimate 1938/39. £	Approx. Outlay 1938/39. £	Estimate for 1939/40. £
FIRE BRIGADE (GENERAL EXPENSES).					
650	202	Fixing New Fire Hydrants	750	734	750
18	203	Maintenance of Hydrants	75	80	75
1426	204	Rental and Upkeep of Fire Alarms	1712	1404	1532
256	205	Installation of Fire Alarms	400	314	400
565	206	Renewals Fund (Gamewell Alarms)	600	597	636
87	207	Telephone Service	90	100	100
49	208	Workmen's Compensation Insurance	50	68	77
55	209	Printing, Stationery and Postages	50	110	60
16	210	Conference Expenses and Sundries	20	21	20
£3122			£3747	£3428	£3650

MOTOR VEHICLES—FIRE BRIGADE (including Renewals Fund).					
188	211	Fire Engine No. 1 (Central)	200	197	214
244	212	Fire Engine No. 2 (Central)	250	257	257
213	213	Fire Engine No. 3 (Mill Hill)	226	223	231
160	214	Fire Engine No. 4 (Mill Hill)	170	172	175
412	215	Motor Water Tower Ladder	450	409	419
531	216	Ambulance No. 1 (Central)	527	541	512
543	217	Ambulance No. 2 (Mill Hill)	530	505	526
301	218	General Utility Van (Central)	315	287	314
211	219	General Utility Van (Mill Hill)	220	215	228
77	220	Austin Car (Central)	90	90	100
£2880			£2978	£2896	£2976

SUMMARY OF COMMITTEE OUTLAY.					
1814	221	Public Depôt (Hendon Way)	1855	1948	1885
561	222	Public Depôt (Mill Hill)	569	738	744
37	223	Public Depôt (Golders Green)	38	38	38
2412			2462	2724	2667
143	224	Council's Cottages	257	291	309
4736	225	Sewers, etc.	5186	4857	4756
534	226/28	Emptying Cesspools	496	509	1060
20454	229	House Refuse Removal	21623	22307	23091
10942	230	Refuse Destructor Works	10333	10250	9888
1019	231	Haymaking and Grass Cutting	932	398	395
926	232	Open Air Bath (West Hendon)	1602	1752	1779
2110	233	Open Air Bath (Mill Hill)	2076	1933	2020
871	234	Slipper Baths (West Hendon)	885	882	896
750	235	Slipper Baths (Child's Hill)	793	748	778
5692	236	Public Conveniences	6610	6278	6585
3996	237	Fire Brigade (Central Station)	3990	5368	6258
5378	238	Fire Brigade (Mill Hill Station)	5353	5981	5933
3122	239	Fire Brigade (General Expenses)	3747	3428	3650
2880	240	Motor Vehicles—Fire Brigade	2978	2896	2976
£65965			£69323	£70602	£73041

For Loan Charges see Finance, etc.,
Committee Estimates.

PUBLIC CONVENIENCES—Details of Estimates of Expenditure.

Outlay 1937-38	Approximate Outlay 1938-39	Expenditure.	The Bell.		West Hendon.		Child's Hill.		Cricklowood Lane.		Orange Hill Road.		Mill Hill.		Edgware.		Hendon Central.		Total.		
			Estimate 1938-39.	Suggested Figures 1939-40.	Estimate 1938-39.	Suggested Figures 1939-40.	Estimate 1938-39.	Suggested Figures 1939-40.	Estimate 1938-39.	Suggested Figures 1939-40.	Estimate 1938-39.	Suggested Figures 1939-40.	Estimate 1938-39.	Suggested Figures 1939-40.	Estimate 1938-39.	Suggested Figures 1939-40.	Estimate 1938-39.	Suggested Figures 1939-40.	Estimate 1938-39.	Suggested Figures 1939-40.	Estimate 1938-39.
£	£																				
4148	4765	Wages	724	747	724	737	724	731	99	87	719	737	719	737	719	737	360	737	4788	5250	
42	66	Materials—Repairs	25	25	15	12	10	10	25	5	10	12	10	10	10	10	5	5	110	89	
116	144	Cleaning Sundries and Towel Service	15	22	15	15	15	20	18	20	20	20	20	20	20	20	10	20	130	167	
439	482	Electricity, Gas and Water	55	55	70	65	60	65	24	25	64	60	65	65	90	107	35	95	463	537	
113	116	Rates and Insurances	31	32	20	20	22	23	19	19	1	1	19	20	17	1	9	20	138	136	
27	68	Rent of Sites	—	—	—	—	—	—	20	20	—	—	7	7	—	—	25	50	52	77	
771	617	New Conveniences (1/5th of Capital Cost)	—	—	—	—	—	—	—	—	—	—	311	—	306	—	—	—	617	—	
36	20	Uniforms and Sundries	6	8	4	8	4	8	1	3	4	8	5	8	5	8	3	8	32	59	
£5692	£6278		£850	£889	£845	£857	£835	£857	£206	£179	£818	£838	£1156	£867	£1167	£883	£447	£935	£6830	£6305	

Income 1937/38 £
 2200
 167
 176
 98
 £2641
 £350
 339
 2
 £341
 128
 5
 8
 68
 50
 143
 67
 £469
 184
 124
 £308
 1662
 295
 179
 70
 16
 85
 105
 5
 £2417

WORKS AND FIRE BRIGADE COMMITTEE

ESTIMATES OF INCOME, 1939/40.

Income 1937/38. £	Item.	Income.	Approved Estimate 1938/39. £	Approx. Income 1938/39. £	Estimate for 1939/40. £
PUBLIC DEPOTS.					
2200	241	Surplus from Stores	1950	1950	2000
167	242	Rent of Workshop (Transfer)	200	200	200
176	243	Rent of Sheds, Offices, etc. (Transfer)	175	196	260
98	244	Rent of Garages (Transfer)	123	106	141
—	245	Post Office—Rent of Land	—	39	26
<u>£2641</u>			<u>£2448</u>	<u>£2491</u>	<u>£2627</u>
COUNCIL'S COTTAGES (EMPLOYEES).					
£350	246	Rents of Cottages, Flats, etc.	£347	£374	£439
SEWERS.					
339	247	Contributions—Boundary Property	450	330	330
—	248	Contributions—Buildings over Sewers	—	2	2
2	249	Easements	5	5	5
<u>£341</u>			<u>£455</u>	<u>£337</u>	<u>£337</u>
SURPLUS SEWAGE LANDS.					
128	250	Rent—Brent Hill Farm (including Insurance)	128	128	128
5	251	Rent—Rifle Range	15	5	5
8	252	Rent—Sundry Lands	4	4	4
68	253	Rent—Destructor Works (Transfer)	68	68	68
50	254	Rent—Stables (Transfer)	50	—	—
143	255	Rent—Allotments (Transfer)	145	145	145
67	256	Rent—Public Depôts (Transfer)	67	67	67
<u>£469</u>			<u>£477</u>	<u>£417</u>	<u>£417</u>
HOUSE REFUSE REMOVAL.					
184	257	Fees for Special Collections (General)	200	180	220
124	258	Fees for Special Collections (Mill Hill Barracks)	124	124	124
<u>£308</u>			<u>£324</u>	<u>£304</u>	<u>£344</u>
REFUSE DESTRUCTOR WORKS.					
1662	259	Sale of Materials	1350	1186	1100
295	260	Fees—Incoming Trade Refuse	250	319	325
179	261	Fine Ash for Outfall Works (Transfer)	—	185	185
70	262	Destruction of School Refuse	75	70	80
Electricity supplied to:—					
—	263	Clinker Crusher	—	12	15
16	264	Workshop	20	10	15
85	265	Rents of Cottages	85	85	85
105	266	Rents of Garages (Transfer)	90	105	105
5	267	Weighbridge Fees	5	1	1
—	268	Miscellaneous	5	—	5
<u>£2417</u>			<u>£1880</u>	<u>£1973</u>	<u>£1916</u>

WORKS AND FIRE BRIGADE COMMITTEE (Contd.).

Income 1937/38. £	Item.	Income.	Approved Estimate 1938/39. £	Approx. Income 1938/39. £	Estimate for 1939/40. £
HAYMAKING AND GRASS CUTTING.					
500	269	Value of Hay Won	430	75	75
519	270	Charges to Accounts (Transfers)	502	323	320
£1019			£932	£398	£395
OPEN AIR BATH (WEST HENDON).					
563	271	Bathers' Fees and Car Park Charges	1000	797	1000
15	272	Refreshment Privilege	20	25	50
1	273	Miscellaneous	10	2	11
£579			£1030	£824	£1061
OPEN AIR BATH (MILL HILL).					
2205	274	Bathers' Fees and Car Park Charges	3000	1608	3000
100	275	Refreshment Privilege	30	35	65
2	276	Insurance Premium <i>re</i> Café	2	2	2
8	277	Miscellaneous	15	3	10
£3315			£3047	£1648	£3077
SLIPPER BATHS—WEST HENDON.					
£344	278	Bathers' Fees	£325	£323	£325
SLIPPER BATHS—CHILD'S HILL.					
£169	279	Bathers' Fees	£175	£156	£175
PUBLIC CONVENIENCES.					
130	280	West Hendon—Rent of Shops	130	130	130
3	281	West Hendon—Insurance of Shops	3	3	3
65	282	West Hendon—Convenience Fees	65	70	70
10	283	West Hendon—Licence <i>re</i> Staircase	10	—	—
6	284	West Hendon—Weighing Machine	3	3	3
214			211	206	206
116	285	The Bell—Fees and Weighing Machine	123	115	114
1	286	The Bell—Easement	1	1	1
108	287	Child's Hill—Fees	110	105	110
118	288	Cricklewood Lane—Fees	110	115	115
82	289	Orange Hill—Fees	80	75	80
97	290	Mill Hill—Fees	90	103	100
69	291	Edgware—Fees	70	70	70
—	292	Hendon Central—Fees	50	18	60
£805			£845	£808	£856
FIRE BRIGADE (CENTRAL STATION).					
323	293	Rents of Quarters	345	402	430
91	294	Expenses Recovered	80	26	—
—	295	Charges for Special Services	—	5	10
£424			£425	£433	£440

Income
1937/38.
£

748

67

£815

10

18

1

£29

237

312

7

£556

2641

350

341

469

308

2417

1019

579

2315

344

169

805

424

815

29

556

£13581

WORKS AND FIRE BRIGADE COMMITTEE (Contd.).

Income 1937/38. £	Item.	Income.	Approved Estimate 1938/39. £	Approx. Income 1938/39. £	Estimate for 1939/40. £
FIRE BRIGADE (MILL HILL STATION).					
748	296	Rents of Quarters	748	748	748
67	297	Expenses Recovered	75	33	—
—	298	Charges for Special Services	—	5	10
—	299	Hire of Rooms (A.R.P.)	—	3	5
<u>£815</u>			<u>£823</u>	<u>£789</u>	<u>£763</u>

FIRE BRIGADE (GENERAL).					
10	300	Rent—Child's Hill Site	10	10	10
18	301	Fire Appliance Certificates	15	16	16
—	302	Sale of Old Equipment	5	—	5
1	303	Miscellaneous	5	—	5
<u>£29</u>			<u>£35</u>	<u>£26</u>	<u>£36</u>

MOTOR VEHICLES (FIRE BRIGADE).					
237	304	Ambulance No. 1 (Central)—Fees for Hire	325	365	375
312	305	Ambulance No. 2 (Mill Hill)—Fees for Hire	200	208	210
7	306	General Utility Van No. 1 (Central)— Fees for Hire	5	4	5
—	307	General Utility Van No. 2 (Mill Hill)— Fees for Hire	—	1	1
<u>£556</u>			<u>£530</u>	<u>£578</u>	<u>£591</u>

SUMMARY OF COMMITTEE INCOME.					
2641	308	Public Depôts	2448	2491	2627
350	309	Council's Cottages (Employees)	347	374	439
341	310	Sewers	455	337	337
469	311	Surplus Sewage Lands	477	417	417
308	312	House Refuse Removal	324	304	344
2417	313	Refuse Destructor Works	1880	1973	1916
1019	314	Haymaking and Grass Cutting	932	398	395
579	315	Open Air Bath (West Hendon)	1030	824	1061
2315	316	Open Air Bath (Mill Hill)	3047	1648	3077
344	317	Slipper Baths—West Hendon	325	323	325
169	318	Slipper Baths—Child's Hill	175	156	175
805	319	Public Conveniences	845	808	856
424	320	Fire Brigade (Central Station)	425	433	440
815	321	Fire Brigade (Mill Hill Station)	823	789	763
29	322	Fire Brigade (General)	35	26	36
556	323	Motor Vehicles (Fire Brigade)	530	578	591
<u>£13581</u>			<u>£14098</u>	<u>£11879</u>	<u>£13799</u>

Works and Fire Brigade Committee

SUMMARY AND NOTES ON ESTIMATES, 1939/40.

OUTLAY.				INCOME.								COMPARISON 1939/40 ESTIMATES WITH 1938/39 RESULTS.			
1937/38 Actual.		1938/39 1939/40 Estimate. Estimate.		No.	DETAILS.	1938/39 1939/40 Estimate. Estimate.		1938/39 1939/40 Estimate. Estimate.		Outlay.		Income.		Rate Charge.	
£	£	£	£			£	£	£	£	£	£	£	£	£	£
2412	2462	2724	2667	1	Public Depôts	2641	2448	2401	2627	57	—	—	136	193	—
143	257	291	309	2	Council's Cottages (Employees)	350	347	374	439	—	18	—	65	47	—
4736	5186	4857	4756	3	Sewers, etc.	311	455	337	337	101	—	—	—	101	—
534	496	509	1060	4	Emptying Cesspools	—	—	—	—	—	551	—	—	—	551
—	—	—	—	5	Surplus Sewage Lands	469	477	417	417	—	—	—	—	—	—
20474	21623	22307	23091	6	House Refuse Removal	308	324	304	344	—	784	—	40	—	744
10942	10333	10250	9888	7	Refuse Destructor Works	2417	1880	1973	1916	362	—	—	—	303	—
1019	932	398	395	8	Haymaking and Grass Cutting	1019	932	398	395	3	—	3	—	—	—
926	1662	1752	1779	9	Open Air Bath (West Hendon)	579	1030	824	1061	—	27	—	237	210	—
2110	2076	1933	2020	10	Open Air Bath (Mill Hill)	2315	3047	1648	3077	—	87	—	1429	1342	—
871	885	882	896	11	Slipper Baths (West Hendon)	344	325	323	325	—	14	—	2	—	12
759	793	748	778	12	Slipper Baths (Child's Hill)	169	175	156	175	—	30	—	19	—	—
5692	6610	6278	6385	13	Public Conveniences	805	845	808	856	—	807	—	48	—	259
3396	3990	3368	6258	14	Fire Brigade (Central Stn.)	424	425	433	440	—	890	—	7	—	883
5378	5253	5981	5933	15	Fire Brigade (Mill Hill Stn.)	815	823	780	763	48	—	26	—	92	—
3122	3747	3428	3650	16	Fire Brigade (General Expenses)	29	35	26	36	—	222	—	10	—	212
2880	2978	2806	2976	17	Motor Vehicles (Fire Brigade)	556	530	578	591	—	80	—	13	—	67
65065	69323	76602	73041	18	Less Income	£13581	£14098	£11879	£13799	£571	£3010	£86	£2006	£2290	£739
13581	14068	11879	13799	19	Balance—Rate Charge	£52284	£55225	£58723	£59242	Less	2220	—	—	—	£519

MEMORANDA.

Reference
to Table.

Head of Service.

- 1 **Public Depôts.—**
Increased rent income for use of garages, offices, etc., at new Mill Hill Depôt. Provision for fencing and machinery at Hendon Way Depôt does not recur.
- 2 **Council's Cottages (Employees).—**
Full year's income for rent of houses at new Mill Hill Depôt.
- 3 **Sewers, etc.—**
Decrease mainly due to work on Silk Valley Sewer Overflows having been completed in 1938/39.
- 4 **Emptying Cesspools.—**
Provision for purchase of new Cesspool Emptying Machine and the incidental upkeep costs.
- 5 **Surplus Sewage Lands.—**
No observations.
- 6 **House Refuse Removal.—**
Increase mainly on wages due to additional number of men employed to deal with increased volume of house refuse.
- 7 **Refuse Destructor Works.—**
Special provisions for new roadways and erection of Clinker Crushing Plant now disappear from the Estimates. New provision for purchase of Mechanical Shovel.
- 8 **Haymaking and Grass Cutting.—**
No observations.
- 9 **Open Air Bath (West Hendon).—**
Allowance made for increased receipts. The takings for last season were below normal on account of bad weather conditions.
- 10 **Open Air Bath (Mill Hill).—**
See note to previous item.
- 11 **Slipper Baths (West Hendon).—**
No observations.
- 12 **Slipper Baths (Child's Hill).—**
No observations.
- 13 **Public Conveniences.—**
Provision made for full year's charges in respect of new Convenience at Hendon Central, and for uniforms for attendants at all Conveniences.
- 14/15 **Fire Brigade (Central and Mill Hill Stations).—**
Increase due to re-organisation of Brigade, appointment of additional officers and men, and the operation of the London County Council scales of pay for a full year in 1939/40.
- 16 **Fire Brigade (General Expenses).—**
Increase for additional Fire Alarms, and the incidental rental and upkeep thereof.
- 17 **Motor Vehicles—Fire Brigade.—**
Sundry minor increases for upkeep of Engines, Ambulances, etc.

AIR RAID PRECAUTIONS (FIRE SERVICES).

The Estimates for A.R.P. (Fire Service) have been approved by the Air Raid Precautions Committee (see page 62). If, and when, proposals as to revision of the Standing Orders become operative, this service will come under the control of the Works and Fire Brigade Committee.

ESTATES PARKS AND ALLOTMENTS COMMITTEE

ESTIMATES OF EXPENDITURE, 1939/40.

Outlay 1937/38. £	Item.	Expenditure.	Approved Estimate 1938/39. £	Approx. Outlay 1938/39. £	Estimate for 1939/40. £
HENDON PARK (29.358 acres).					
1152	324	Wages	1199	1227	1239
91	325	Materials (Grounds, Courts and Buildings)	120	103	75
11	326	Equipment (Courts and Greens)	20	19	15
120	327	Council's Team Labour	140	35	20
49	328	Hired Lorries and Team Labour	38	55	50
15	329	Work done by Petrol Rollers	16	103	130
18	330	Work done by Motor Tractor and Mowing Units	15	9	10
288	331	Shrubs, Plants and Seeds	225	257	253
17	332	Tools and Plant (including repairs)	20	22	22
3	333	Gymnastic Apparatus (including repairs)	5	11	6
34	334	Water Supply	35	50	40
112	335	Band Performances	120	108	120
—	335a	Children's Entertainments	—	—	10
3	336	Insurance	2	4	4
—	337	Uniforms	12	12	24
1	338	Sundries	3	5	5
1914			1970	2020	2025
—	339	Tree Felling	15	12	15
22	340	Park Seats	10	17	20
266	341	Conversion of Tennis Courts	—	—	—
37	342	Demolition of Cottage	—	—	—
—	343	Spraying Tennis Courts	—	—	100
—	344	Fencing Railway Boundary	60	—	—
34	345	Fencing Convenience	—	—	—
£2273			£2055	£2049	£2160
CHILD'S HILL PARK (7.161 acres).					
493	346	Wages	480	493	497
59	347	Materials (Grounds, Courts and Buildings)	39	47	78
—	348	Equipment (Courts and Greens)	5	4	10
14	349	Council's Team Labour	10	7	10
21	350	Hired Lorries and Team Labour	17	18	17
22	351	Work done by Petrol Rollers	30	28	30
8	352	Work done by Motor Tractor and Mowing Units	10	10	10
44	353	Shrubs, Plants and Seeds	45	26	40
3	354	Tools and Plant (including repairs)	7	3	7
—	355	Gymnastic Apparatus (including repairs)	5	1	5
40	356	Water Supply	45	50	45
—	356a	Children's Entertainments	—	—	10
1	357	Insurance	1	1	1
5	358	Uniforms	—	—	9
—	359	Sundries	5	4	5
710			699	702	774
—	360	Tree Lopping	5	5	5
17	361	Park Seats	10	16	16
—	362	Purchase of Mowing Machine	16	15	—
£727			£730	£738	£795

ESTATES, PARKS AND ALLOTMENTS COMMITTEE (Contd.).

Outlay 1937/38. £	Item.	Expenditure.	Approved Estimate 1938/39. £	Approx. Outlay 1938/39. £	Estimate for 1939/40. £
SUNNY HILL PARK (51.292 acres).					
1029	363	Wages	1104	1135	1147
71	364	Materials (Grounds, Courts and Buildings)	73	95	91
4	365	Equipment (Courts and Greens)	15	14	15
4	366	Council's Team Labour	10	—	5
23	367	Hired Lorries and Team Labour	17	21	20
18	368	Work done by Petrol Rollers	20	9	10
153	369	Work done by Motor Tractor and Mowing Units	140	118	125
3	370	Shrubs, Plants and Seeds	40	16	20
14	371	Tools and Plant (including repairs)	15	21	20
7	372	Gymnastic Apparatus (including repairs)	5	—	25
6	373	Water Supply	12	10	12
—	374	Uniforms	12	12	12
1	375	Sundries	3	5	5
1333			1466	1456	1507
30	376	Provision of Seats	15	23	25
286	377	Fencing Great North Way	—	—	—
—	378	Tree Felling	10	—	5
56	379	Water Supply to Cricket Pitches	—	—	—
—	380	Rebuilding Kiosk (Balance)	—	38	—
—	381	Fencing and Lay-out (Pond)	150	85	45
£1705			£1641	£1602	£1582
MILL HILL PARK (38.753 acres).					
905	382	Wages	930	960	1008
83	383	Materials (Grounds, Courts and Buildings)	96	78	88
3	384	Equipment (Courts and Greens)	5	19	15
—	385	Council's Team Labour	5	—	5
29	386	Hired Lorries and Team Labour	17	29	25
18	387	Work done by Petrol Rollers	10	24	25
92	388	Work done by Motor Tractor and Mowing Units	100	102	105
15	389	Shrubs, Plants and Seeds	20	11	20
12	390	Tools and Plant (including repairs)	15	25	20
2	391	Gymnastic Apparatus (including repairs)	5	—	5
22	392	Water Supply	25	28	25
1	393	Insurances	1	1	1
—	394	Uniforms	14	14	5
29	395	Haymaking and Grass Cutting	45	—	—
2	396	Sundries	3	3	3
1213			1291	1294	1350
14	397	Provision of Seats	10	16	16
45	398	Laying on Water Supply to Cricket Pitches	—	—	—
1	399	Tree Felling and Lopping	10	23	15
—	400	New Footpaths	—	—	100
177	401	Making up Frontage—The Rise	—	—	—
£1450			£1311	£1333	£1481

ESTATES, PARKS AND ALLOTMENTS COMMITTEE (Contd.).

Outlay 1937/38. £	Item.	Expenditure.	Approved Estimate 1938/39. £	Approx. Outlay 1938/39. £	Estimate for 1939/40. £
PRINCES PARK (3.5 acres).					
431	402	Wages	480	442	479
22	403	Materials (Grounds, Courts and Buildings)	70	28	37
—	404	Equipment (Courts and Greens)	10	17	10
23	405	Council's Team Labour	20	18	18
12	406	Hired Lorries and Team Labour	12	17	15
1	407	Work done by Petrol Rollers	3	2	3
3	408	Work done by Tractor and Mowing Units	5	3	5
30	409	Shrubs, Plants and Seeds	30	28	30
4	410	Tools and Plant (including repairs)	5	10	14
—	411	Gymnastic Apparatus (including repairs)	5	12	5
5	412	Water Supply	8	6	8
1	413	Insurance	1	1	1
—	414	Uniforms	2	2	—
—	415	Sundries	—	3	3
532			651	589	628
6	416	Tree Lopping	5	—	5
—	417	Fencing Borders	—	—	16
£538			£656	£589	£649
BASING HILL PARK (6.56 acres).					
459	418	Wages	469	486	485
39	419	Materials (Grounds, Courts and Buildings)	53	39	70
3	420	Equipment (Courts and Greens)	15	8	15
11	421	Council's Team Labour	10	4	5
21	422	Hired Lorries and Team Labour	17	19	18
26	423	Work done by Petrol Rollers	30	27	30
4	424	Work done by Motor Tractor and Mowing Units	5	3	5
51	425	Shrubs, Plants and Seeds	45	51	45
9	426	Tools and Plant (including repairs)	10	15	12
1	427	Gymnastic Apparatus (including repairs)	5	—	5
12	428	Water Supply	15	20	20
1	429	Insurance	1	1	1
—	430	Uniforms	—	—	10
—	431	Sundries	3	3	3
637			678	676	724
—	432	Tree Lopping	—	5	—
8	433	Park Seats	5	8	8
45	434	Purchase of Motor Mower	—	—	—
£690			£683	£689	£732
WATLING PARK (21 acres).					
1205	435	Wages	1413	1384	1490
94	436	Materials (Grounds, Courts and Buildings)	70	74	73
1299		Carried forward	1483	1458	1563

ESTATES, PARKS AND ALLOTMENTS COMMITTEE (Contd.).

Outlay 1937/38. £	Item.	Expenditure.	Approved Estimate 1938/39. £	Approx. Outlay 1938/39. £	Estimate for 1939/40. £
WATLING PARK (Continued).					
1299		Brought forward	1483	1458	1563
7	437	Equipment (Courts and Greens)	10	2	10
6	438	Council's Team Labour	10	11	10
77	439	Hired Lorries and Team Labour	77	42	55
5	440	Work done by Petrol Rollers	10	29	30
18	441	Work done by Motor Tractor and Mow- ing Units	10	18	10
164	442	Shrubs, Plants and Seeds	150	136	140
25	443	Tools and Plant (including repairs)	24	24	25
8	444	Gymnastic Apparatus (including repairs)	5	19	18
18	445	Water Supply	20	27	25
132	446	Band Performances	125	125	125
—	446a	Children's Entertainments	—	—	10
—	447	Uniforms	12	12	24
3	448	Sundries	3	4	5
1762			1039	1907	2050
6	449	Tree Lopping	10	10	10
—	450	Fencing to Stream and Borders	—	—	32
—	451	Fencing between Bridges	50	52	—
—	452	Seats	20	33	16
303	453	Conversion of Two Tennis Courts	60	60	—
—	454	Provision of Shelter	—	—	150
—	455	Provision of Bandstand	—	—	400
£2071			£2079	£2062	£2658
COLINDALE PARK (2.85 acres).					
305	456	Wages	277	257	276
31	457	Materials (Grounds, Courts and Build- ings)	26	7	25
14	458	Council's Team Labour	15	12	15
9	459	Hired Lorries and Team Labour	6	5	6
1	460	Work done by Petrol Rollers	3	3	3
2	461	Work done by Motor Tractors and Mow- ing Units	—	—	—
4	462	Shrubs, Plants and Seeds	5	2	3
1	463	Tools and Plant (including repairs)	2	3	3
8	464	Gymnastic Apparatus (including repairs)	5	—	5
4	465	Water Supply	5	4	5
5	466	Sundries	—	—	2
384			344	293	343
—	467	Tree Lopping	10	5	10
—	468	Fencing Borders	—	—	10
7	469	Park Seats	5	8	—
£391			£359	£306	£363
BITTACY HILL PARK (6.65 acres).					
—	470	Wages	250	203	240
—	471	Materials (Grounds, etc.)	—	4	20
—	472	Hired Lorries and Team Labour	20	4	15
—	473	Work done by Petrol Rollers	5	—	3
—	474	Work done by Motor Tractor	—	2	3
—	475	Shrubs, Plants and Seeds	—	—	20
—	476	Tools and Plant (including repairs)	10	6	5
—	477	Gymnastic Apparatus (including repairs)	5	—	5
—	478	Uniforms	6	—	6
8	479	Haymaking and Grass Cutting	—	—	—
—	480	Sundries	—	—	3
8		Carried forward	296	219	320

ESTATES, PARKS AND ALLOTMENTS COMMITTEE (Contd.).

Outlay 1937/38. £	Item.	Expenditure.	Approved Estimate 1938/39. £	Approx. Outlay 1938/39. £	Estimate for 1939/40. £
BITTACY HILL PARK (Continued).					
8		Brought forward	296	219	320
—	481	Tree Lopping	—	—	5
—	482	Provision of Seats	—	—	8
30	483	Land for New Entrance	—	—	—
—	484	Lay-out of Grounds	400	546	—
<u>£38</u>			<u>£696</u>	<u>£765</u>	<u>£333</u>
YORK PARK (3.572 acres).					
273	485	Wages	277	293	266
11	486	Materials (Grounds, Courts and Buildings)	13	8	23
23	487	Council's Team Labour	25	22	25
8	488	Hired Lorries and Team Labour	6	6	6
—	489	Work done by Petrol Rollers	5	4	5
3	490	Work done by Tractor and Mowing Units	3	1	3
—	491	Shrubs, Plants and Seeds	3	1	8
1	492	Tools and Plant (including repairs)	5	4	5
7	493	Gymnastic Apparatus (including repairs)	5	1	5
4	494	Water Supply	5	4	5
—	495	Uniforms	—	—	11
—	496	Sundries	—	—	3
330			347	344	365
32	497	Park Seats	—	—	16
131	498	Lay-out of Grounds (1/7th Cost)	131	131	131
—	499	Park Keeper's Hut	25	31	—
<u>£493</u>			<u>£503</u>	<u>£506</u>	<u>£512</u>
WOODCROFT PARK (7.26 acres).					
427	500	Wages	462	437	453
18	501	Materials (Grounds, Courts and Buildings)	23	13	37
—	502	Equipment (Courts and Greens)	—	—	5
6	503	Council's Team Labour	5	4	12
13	504	Hired Lorries and Team Labour	12	13	20
3	505	Work done by Petrol Rollers	20	19	—
18	506	Work done by Tractors and Mowing Units	10	8	10
41	507	Shrubs, Plants and Seeds	45	38	40
4	508	Tools and Plant (including repairs)	8	6	8
15	509	Gymnastic Apparatus (including repairs)	5	7	5
6	510	Water Supply	6	4	6
—	511	Uniforms	—	—	3
—	512	Sundries	—	—	—
551			596	549	604
—	513	Fencing	—	—	50
—	514	Tree Lopping	5	—	5
7	515	Seats	10	15	—
<u>£558</u>			<u>£611</u>	<u>£564</u>	<u>£659</u>

ESTATES, PARKS AND ALLOTMENTS COMMITTEE (Contd.).

Outlay 1937/38. £	Item.	Expenditure.	Approved Estimate 1938/39. £	Approx. Outlay 1938/39. £	Estimate for 1939/40. £
SILKSTREAM PARK (10.820 acres).					
445	516	Wages	461	489	454
46	517	Materials (Grounds, Courts and Buildings)	16	38	27
68	518	Council's Team Labour	60	20	45
17	519	Hired Lorries and Team Labour	12	26	10
1	520	Work done by Petrol Rollers	5	4	5
2	521	Work done by Motor Tractor and Mowing Units	3	3	3
43	522	Shrubs, Plants and Seeds	35	38	40
23	523	Tools and Plant (including repairs)	12	8	10
1	524	Gymnastic Apparatus	5	7	5
—	525	Uniforms	—	—	12
4	526	Water Supply	5	4	5
—	527	Sundries	—	—	3
650			614	637	619
—	528	Tree Lopping	5	—	5
14	529	Provision of Seats	10	16	—
—	530	Purchase of Motor Mower	52	48	—
8	531	Laying on Water Supply	—	—	—
£672			£681	£701	£624
WOODFIELD PARK (39.788 acres).					
353	532	Wages	331	351	290
1	533	Materials—Grounds	5	9	18
—	534	Equipment—Grounds	—	—	5
6	535	Coke—Woodfield House	—	—	—
2	536	Council's Team Labour	5	1	5
—	537	Hired Lorries and Team Labour	6	1	5
—	538	Work done by Petrol Rollers	5	11	10
14	539	Work done by Motor Tractor and Mowing Units	5	10	10
—	540	Tools and Plant (including repairs)	5	3	5
—	541	Uniforms	—	—	5
7	542	Insurances	—	—	—
104	543	Haymaking and Grass Cutting	160	118	80
4	544	Water Supply	—	3	—
6	545	Sundries	5	—	5
497			527	507	438
Upkeep of Cottages.					
—	546	Rates and Insurance	10	12	30
—	547	Telephone Service	4	6	8
—	548	Water and Sundries	2	2	2
497			543	527	478
16	549	Fencing and New Entrance Gates	55	40	—
£513			£598	£567	£478

ESTATES, PARKS AND ALLOTMENTS COMMITTEE (Contd.).

Outlay 1937/38. £	Item.	Expenditure.	Approved Estimate 1938/39. £	Approx. Outlay 1938/39. £	Estimate for 1939/40. £
EDGWAREBURY PARK (39.41 acres).					
415	550	Wages	455	438	449
14	551	Materials (Grounds, Courts and Buildings)	20	12	13
—	552	Equipment (Grounds, Courts and Buildings)	—	4	—
5	553	Hired Lorries and Team Labour	10	6	10
155	554	Work done by Petrol Rollers	145	148	150
16	555	Work done by Motor Tractor and Mowing Units	5	5	5
4	556	Shrubs, Plants and Seeds	—	1	2
5	557	Tools and Plant (including repairs)	8	5	8
—	558	Water Supply	3	—	5
—	559	Uniforms	—	—	5
—	560	Sundries	5	1	5
—	561	Tree Lopping	5	—	5
5	562	Seats	10	11	12
<u>£619</u>			<u>£666</u>	<u>£631</u>	<u>£669</u>
LYNDHURST PARK (7.2 acres).					
252	563	Wages	266	265	266
7	564	Materials (Grounds, Courts and Buildings)	5	6	8
—	565	Council's Team Labour	—	—	—
5	566	Hired Lorries and Team Labour	38	21	20
—	567	Work done by Petrol Rollers	5	27	40
—	568	Work done by Motor Tractor	—	1	3
4	569	Shrubs, Plants and Seeds	10	3	5
6	570	Tools and Plant (including repairs)	5	2	5
—	571	Water Supply	3	—	—
—	572	Uniforms	—	—	5
1	573	Sundries	5	—	2
—	574	Tree Lopping	10	—	5
16	575	Haymaking and Grass Cutting	25	—	—
<u>£291</u>			<u>£372</u>	<u>£325</u>	<u>£359</u>
DEANSBROOK PARK (including Station Road (Edgware) Open Space) (9.88 acres).					
482	576	Wages	—	26	—
2	577	Materials (Grounds, Courts and Buildings)	—	—	—
6	578	Hired Lorries and Team Labour	—	—	—
10	579	Work done by Petrol Rollers	—	—	—
1	580	Tools and Plant (including repairs)	—	—	—
7	581	Gymnastic Apparatus	—	—	—
6	582	Haymaking and Grass Cutting	—	—	—
<u>£514</u>			<u>—</u>	<u>£26</u>	<u>—</u>

ESTATES, PARKS AND ALLOTMENTS COMMITTEE (Contd.).

Outlay 1937/38. £	Item.	Expenditure.	Approved Estimate 1938/39. £	Approx. Outlay 1938/39. £	Estimate for 1939/40. £
STONEGROVE PARK (7.13 acres).					
607	583	Wages	636	640	655
51	584	Materials (Grounds, Courts and Buildings)	28	25	41
4	585	Equipment (Courts and Greens)	10	11	12
2	586	Council's Team Labour	—	2	—
37	587	Hired Lorries and Team Labour	22	30	25
17	588	Work done by Petrol Rollers	35	27	35
7	589	Work done by Motor Tractor and Mowing Units	5	2	5
130	590	Shrubs, Plants and Seeds	120	99	115
3	591	Tools and Plant (including repairs)	10	8	10
1	592	Gymnastic Apparatus (including repairs)	5	—	5
23	593	Water Supply	20	25	25
—	594	Uniforms	16	16	2
—	595	Sundries	—	2	3
882			907	887	933
—	596	Spraying Courts	70	96	—
£882			£977	£983	£933
BRENT PARK (6.45 acres).					
429	597	Wages	459	451	458
9	598	Materials (Grounds, Courts and Buildings)	35	21	30
2	599	Council's Team Labour	5	1	5
21	600	Hired Lorries and Team Labour	12	11	12
1	601	Motor Tractor and Mowing Units	3	3	3
9	602	Shrubs, Plants and Seeds	40	19	20
2	603	Tools and Plant (including repairs)	5	5	5
—	604	Water Supply	—	—	3
—	605	Uniforms	—	—	12
8	606	Sundries	8	7	8
481			567	518	556
5	607	Tree Lopping	10	6	10
197	608	Fencing Bridge Lane Entrance	—	—	—
—	609	Gates and Fencing	60	—	80
7	610	Purchase of Mower	—	—	—
10	611	Destruction of Rats	10	—	10
—	612	Laying on Water Supply	—	—	25
£700			£647	£524	£681
ELM PARK (.752 acres).					
270	613	Wages	277	273	270
11	614	Materials (Grounds)	21	22	16
—	615	Council's Team Labour	—	1	—
10	616	Hired Lorries and Team Labour	6	10	10
—	617	Work done by Petrol Roller	2	1	2
2	618	Work done by Tractor and Mowing Units	3	1	3
15	619	Shrubs, Plants and Seeds	20	15	15
16	620	Tools and Plant	5	3	5
6	621	Water Supply	4	3	4
10	622	Uniforms	—	—	—
—	623	Sundries	3	1	3
340			341	330	328
97	624	Layout	10	11	—
—	624a	Park Seats	—	—	20
—	625	Fencing Borders	—	—	—
£437			£351	£341	£348

ESTATES, PARKS AND ALLOTMENTS COMMITTEE (Contd.).

Outlay 1937/38. £	Item.	Expenditure.	Approved Estimate 1938/39. £	Approx. Outlay 1938/39. £	Estimate for 1939/40. £
CLITTERHOUSE PLAYING FIELDS (46.51 acres).					
1081	626	Wages	1130	1106	1193
104	627	Materials (Grounds, Courts and Buildings)	70	51	96
4	628	Equipment (Courts and Greens)	5	9	16
—	629	Council's Team Labour	5	—	—
19	630	Hired Lorries and Team Labour	12	16	15
117	631	Work done by Petrol Rollers	120	40	30
13	632	Work done by Motor Tractor and Mowing Units	10	66	70
9	633	Shrubs, Plants and Seeds	10	5	10
17	634	Tools and Plant (including repairs)	17	21	22
1	635	Gymnastic Apparatus (including repairs)	5	2	5
9	636	Water Supply	12	12	12
—	636a	Children's Entertainments	—	—	10
1	637	Electricity	2	2	2
46	638	Rent and Insurances	46	40	40
5	639	Uniforms	6	6	—
—	640	Sundries	—	3	4
1426			1450	1379	1525
—	641	Shelter	—	—	150
149	642	Refreshment Kiosk	20	31	10
169	643	Water Supply to Pitches and Kiosk	—	—	—
—	644	Destruction of Rats	—	4	4
43	645	Purchase of Motor Mower	—	—	—
—	646	Park Seats	10	17	32
—	647	Fencing Borders	—	—	25
£1787			£1480	£1431	£1746
WEST HENDON PLAYING FIELDS (53.6 acres).					
691	648	Wages	714	689	740
80	649	Materials (Grounds, Courts and Buildings)	45	22	55
—	650	Equipment (Courts and Greens)	10	7	10
9	651	Council's Team Labour	10	—	—
9	652	Hired Lorries and Team Labour	12	10	12
37	653	Work done by Petrol Rollers	30	55	15
76	654	Work done by Motor Tractor and Mowing Units	80	64	95
5	655	Shrubs, Plants and Seeds	5	3	5
10	656	Tools and Plant (including repairs)	12	11	12
—	657	Gymnastic Apparatus (including repairs)	5	—	5
21	658	Water Supply	30	20	25
—	658a	Children's Entertainments	—	—	10
1	659	Insurance	1	1	1
—	660	Uniforms	—	—	14
69	661	Haymaking and Grass Cutting	90	35	40
—	662	Sundries	—	3	5
999			1044	920	1044
—	663	Tree Lopping	5	—	5
94	664	Water Supply to Cricket Pitches	—	—	—
249	665	Conversion of Two Tennis Courts	90	95	—
—	666	Purchase of Motor Mower	52	48	—
£1333			£1191	£1063	£1049

ESTATES, PARKS AND ALLOTMENTS COMMITTEE (Contd.).

Outlay 1937/38. £	Item.	Expenditure.	Approved Estimate 1938/39. £	Approx. Outlay 1938/39. £	Estimate for 1939/40. £
BRENT HILL PLAYING FIELDS (1.7 acres).					
10	667	Wages	15	16	16
2	668	Council's Team Labour	5	4	5
1	669	Hired Lorries and Team Labour	2	—	2
—	670	Gymnastic Apparatus (including repairs)	2	—	2
<u>£13</u>			<u>£24</u>	<u>£20</u>	<u>£25</u>
COPTHALL PLAYING FIELDS (146.25 acres).					
145	671	Wages	460	432	455
6	672	Materials (Grounds, Courts and Buildings)	20	12	28
—	673	Equipment—Football Pitches	—	5	10
13	674	Council's Team Labour	—	6	—
3	675	Hired Lorries and Team Labour	12	11	12
7	676	Work done by Petrol Rollers	35	27	45
16	677	Motor Tractors and Mowing Units	20	27	25
—	678	Work done by Caterpillar Tractor	125	149	130
17	679	Tools and Plant (including repairs)	20	10	10
5	680	Water Supply	5	5	5
5	681	Uniforms	12	12	—
3	682	Sundries	—	—	3
220			718	696	723
—	683	Improving Entrance	—	72	—
—	684	Tree Lopping	10	8	10
—	685	Purchase of 7 Cutting Units	193	183	—
600	686	Purchase of Land—Page Street	600	—	—
<u>£820</u>			<u>£1521</u>	<u>£950</u>	<u>£733</u>
MONTROSE PLAYING FIELDS (30 acres).					
299	687	Wages	699	664	722
10	688	Materials (Grounds, Courts and Buildings)	17	37	63
—	689	Council's Team Labour	—	7	8
—	689a	Equipment (Grounds, Courts and Buildings)	—	1	10
13	690	Hired Lorries and Team Labour	11	17	15
14	691	Work done by Petrol Rollers	10	101	110
45	692	Work done by Motor Tractor and Units	80	12	10
—	693	Shrubs, Plants and Seeds	30	23	30
1	694	Tools and Plant (including repairs)	10	15	15
—	695	Gymnastic Apparatus	5	2	5
2	696	Water Supply	20	16	18
—	697	Uniforms	18	18	—
1	698	Sundries	—	3	3
—	699	Seats	—	2	—
—	700	Tree Lopping	—	—	10
385			900	918	1019
—	701	Pavilion Lighting	—	—	45
<u>£885</u>			<u>£900</u>	<u>£918</u>	<u>£1064</u>

ESTATES, PARKS AND ALLOTMENTS COMMITTEE (Contd.).

Outlay 1937/38, £	Item.	Expenditure.	Approved Estimate 1938/39, £	Approx. Outlay 1938, 39, £	Estimate for 1939/40, £
BURTON HOLE LANE PLAYING FIELDS (9.896 acres).					
—	702	Wages	5	—	5
4	703	Water Supply	4	4	4
£4			£9	£4	£9
MOTE MOUNT OPEN SPACE. (217.239 acres).					
410	704	Wages	464	435	454
7	705	Materials (Grounds, Courts and Build- ings)	20	18	22
3	706	Work done by Petrol Rollers	5	5	5
37	707	Council's Team Labour	30	3	10
10	708	Hired Lorries and Team Labour	12	8	10
11	709	Tools and Plant (including repairs)	7	5	5
—	710	Uniforms	—	—	—
4	711	Sundries	20	8	9
482			558	482	515
—	712	Fencing	50	50	—
—	713	Park Seats	10	11	—
—	713a	Mote Mount Camp Site—Water Supply and Latrines	—	—	500
£482			£618	£543	£1015
ARRANDENE OPEN SPACE (57.27 acres).					
4	714	Wages	5	1	5
4	715	Water Supply	3	4	3
£8			£8	£5	£8
COLINDEEP LANE OPEN SPACE. (7.530 acres).					
2	716	Wages	208	7	25
1	717	Materials—Grounds	10	—	—
—	718	Hired Lorries and Team Labour	12	—	—
—	719	Work done by Petrol Rollers	10	—	—
—	720	Work done by Tractors and Mowing Units	20	—	—
—	721	Tools and Plant	10	—	5
—	722	Uniforms	12	6	—
—	723	Sundries	—	—	3
—	724	Making-up Frontage—Rushgrove Avenue	—	365	—
£3			£282	£378	£33
SCRATCHWOOD OPEN SPACE (145.82 acres).					
416	725	Wages	448	419	446
2	726	Materials (Grounds, Courts and Build- ings)	5	8	10
5	727	Hired Lorries and Team Labour	6	5	6
6	728	Tools and Plant (including repairs)	6	4	6
—	729	Uniforms	—	—	—
—	730	Sundries	3	1	3
429			468	437	471
10	731	Park Seats	10	11	12
134	732	Fencing	—	—	—
7	733	Purchase of Mowing Machine	—	—	—
10	734	Making-up Entrance from Barnet Road	—	—	—
£590			£478	£448	£483

ESTATES, PARKS AND ALLOTMENTS COMMITTEE (Contd.).

Outlay 1937/38. £	Item.	Expenditure.	Approved Estimate 1938/39. £	Approx. Outlay 1938/39. £	Estimate for 1939/40. £
HENDON GROVE (13.25 acres).					
266	735	Wages	266	265	271
6	736	Materials (Grounds and Buildings)	15	20	15
—	737	Council's Team Labour	—	2	—
4	738	Hired Lorries and Team Labour	8	6	8
—	739	Work done by Petrol Rollers	5	—	3
1	740	Work done by Tractor and Mowing Units	—	2	2
5	741	Uniform	2	—	—
4	742	Shrubs, Plants and Seeds	10	5	8
3	743	Tools and Plant	6	4	5
6	744	Rates and Insurance	6	4	—
—	745	Park Seats	5	7	8
7	746	Purchase of Mowing Machine	—	—	—
—	747	Sundries	—	—	5
1	748	Water Supply	2	—	—
—	749	Tree Lopping	—	—	10
£303			£325	£315	£335
THE MILL FIELD (8 acres).					
262	750	Wages	266	269	260
15	751	Materials—Grounds	7	7	14
27	752	Hired Lorries and Team Labour	28	43	50
5	753	Work done by Petrol Rollers	—	2	2
—	754	Work done by Motor Tractor	—	3	2
6	755	Shrubs, Plants and Seeds	3	—	3
7	756	Tools and Plant	6	11	9
5	757	Uniforms	—	—	—
—	758	Sundries	—	—	2
327			310	335	342
15	759	Construction of Paths	—	—	—
26	760	Park Seats	—	7	8
25	761	Parkkeepers' Hut	—	—	—
7	762	Tree Felling	10	10	10
—	763	New Entrance	—	—	15
£403			£320	£352	£375
HARMAN DRIVE OPEN SPACE.					
£663	764	Purchase of Land and Costs	—	—	—
NORTH CIRCULAR ROAD PLAYING FIELDS.					
—	765	Removal of Rifle Range	250	—	—
—	766	Haymaking and Grass Cutting	100	—	—
—			£350	—	—
DEACONS HILL OPEN SPACE (90 acres).					
—	767	Wages	5	3	15
—	768	Materials	5	3	5
194	769	Fencing	—	32	25
96	770	Decorations and Repairs (Farm House)	—	—	—
—	771	Hired Lorries	—	11	5
—	772	Grass Seed	—	—	—
£290			£10	£49	£50
—	772a	EQUIPMENT AND FENCING OF CHILDREN'S PLAYGROUNDS	—	£44	—*

* Provision of £1,000 deleted by Finance and General Purposes Committee, 20/3/39.

ESTATES, PARKS AND ALLOTMENTS COMMITTEE (Contd.).

Outlay 1937/38. £	Item.	Expenditure.	Approved Estimate 1938/39. £	Approx. Outlay 1938/39. £	Estimate for 1939/40. £
RIVERSIDE WALKS.					
265	773	Wages	448	429	444
6	774	Materials	20	12	25
10	775	Hired Lorries and Team Labour	12	12	12
—	776	Work done by Petrol Rollers	—	—	10
—	777	Work done by Motor Tractor	—	3	5
7	778	Shrubs, Plants and Seeds	25	10	10
2	779	Tools and Plant	8	4	7
10	780	Uniforms	—	—	6
300			513	470	519
Making-up Frontages:—					
—	781	Thornfield Avenue	—	306	—
210	782	Lullington Garth	70	—	—
Purchase of Lands:—					
500	783	Thornfield Avenue	—	—	—
80	784	Waverley Grove	—	—	—
—	785	Fencing (Lullington Garth and Fursby Avenue)	55	—	55
—	786	Fencing (Thornfield Avenue)	120	—	120
—	787	Tree Lopping	5	5	10
—	788	Construction of Footbridges	100	—	375
31	789	Park Seats	20	30	16
30	790	Park Keeper's Hut	—	—	—
352	791	Clearing, Levelling and New Paths	400	280	200
£1503			£1283	£1091	£1295
PURCHASE OF PETROL ROLLERS AND TRACTORS.					
—	792	Purchase of Two Tractors	—	—	600
—	793	Purchase of Two Rollers	750	713	—
			£750	£713	£600
NURSERIES ACCOUNT.					
771	794	Wages — Propagators, Gardeners and Watchman	1018	836	948
6	795	Council's Team Labour	5	23	10
29	796	Hired Lorries and Team Labour	25	25	25
94	797	Seeds and Plants	70	44	60
18	798	Manure and Fertilizers	20	15	20
118	799	Coke for Heating Greenhouses	130	133	132
40	800	Flower Pots, Boxes, etc., Chippings and Sand	55	60	65
13	801	Tools and Sundries	15	12	15
75	802	Rent of Nursery Ground (Transfer)	75	75	75
10	803	Insurance	11	15	15
53	804	Repairs and Upkeep of Greenhouses and Buildings	35	70	70
2	805	Work done by Motor Tractor and Mowing Units	5	5	5
—	806	Telephone Service	—	5	6
1229			1464	1318	1441
463	807	Forcing Houses and Cold Frames	—	—	50
—	808	Purchase of Trees	—	—	—
135	809	Lay-out of Tree and Shrub Nursery	100	100	—
—	810	Relaying Water Main	—	19	—
—	811	Replacing Old Greenhouse	—	—	—
£1827			£1564	£1437	£1491

* Provision of £425 deleted by Finance and General Purposes Committee, 20/3/39.

ESTATES, PARKS AND ALLOTMENTS COMMITTEE (Contd.).

Outlay 1937/38. £	Item.	Expenditure.	Approved Estimate 1938/39. £	Approx. Outlay 1938/39. £	Estimate for 1939/40. £
ASSISTANT PARK SUPERINTENDENT'S MOTOR CYCLE (4 H.P. Triumph Combination)—M.Y.644.					
8	812	Petrol	—	—	—
3	813	Repairs and Renewals	—	—	—
5	814	Licence and Insurance	—	—	—
8	815	Depreciation	—	—	—
<u>24</u>			<u>—</u>	<u>—</u>	<u>—</u>
PARKS MOTOR VAN—Austin 7 H.P.					
11	816	Petrol	30	28	30
—	817	Oils and Grease	2	2	2
—	818	Repairs and Renewals	10	8	10
7	819	Wages—Cleaning and Greasing	15	20	15
—	820	Accessories	4	3	4
7	821	Licence and Insurance	16	16	16
2	822	Sundries	—	—	—
9	823	Depreciation	22	22	22
<u>60</u>			<u>99</u>	<u>99</u>	<u>99</u>
64	824	Park Superintendent—Car Allowance	65	65	65
<u>£124</u>			<u>£164</u>	<u>£164</u>	<u>£164</u>
OPEN SPACES, GREENS, AND GARDENS ON HIGHWAYS.					
1128	825	Wages	1265	1310	1551
28	826	Materials	40	42	40
8	827	Council's Team Labour	10	8	10
122	828	Hired Lorries and Team Labour	125	111	120
1	829	Work done by Petrol Rollers	—	2	3
27	830	Work done by Motor Tractor and Mow- ing Units	—	—	—
164	831	Trees, Shrubs, and Plants (Open Spaces)	150	128	145
48	832	Public Seats	30	31	25
17	833	Drinking Fountains and Water Troughs	22	17	20
8	834	Burroughs Pond—Water Supply	10	9	10
31	835	Tools and Plant (including repairs)	25	38	40
13	836	Uniforms (Relief Park Keepers)	—	—	—
6	837	Sundries	3	4	5
<u>1601</u>			<u>1695</u>	<u>1718</u>	<u>1989</u>
57	839	Lay-out—Courtway Open Space (1/7th cost)	57	57	57
127	840	Lay-out—Church Road Open Space	—	—	—
118	841	Holcombe Hill Open Space (Levelling, etc.)	—	—	—
—	842	Purchase of 5 Mowing Machines	—	—	37
—	843	Making up Frontage—Uphill Drive	120	119	—
<u>£1903</u>			<u>£1872</u>	<u>£1894</u>	<u>£2083</u>
<u>£2223</u>	844	ALLOTMENTS	<u>£2400</u>	<u>£2425</u>	<u>£2600</u>

ESTATES, PARKS AND ALLOTMENTS COMMITTEE (Contd.).

Outlay 1937/38. £	Item.	Expenditure.	Approved Estimate 1938/39. £	Approx. Outlay 1938/39. £	Estimate for 1939/40. £
SUMMARY OF COMMITTEE OUTLAY.					
2273	845	Hendon Park	2055	2049	2160
727	846	Child's Hill Park	730	738	795
1705	847	Sunny Hill Park	1641	1602	1582
1450	848	Mill Hill Park	1311	1333	1481
538	849	Princes Park	656	589	649
690	850	Busing Hill Park	683	689	732
2071	851	Watling Park	2079	2062	2658
391	852	Colindale Park	359	306	363
38	853	Bittacy Hill Park	696	765	333
493	854	York Park	503	506	512
558	855	Woodcroft Park	611	564	659
672	856	Silkstream Park	681	701	624
513	857	Woodfield Park	598	567	478
619	858	Edgwarebury Park	666	631	669
291	859	Lyndhurst Park	372	325	359
514	860	Deansbrook Park	—	26	—
882	861	Stonegrove Park	977	983	933
700	862	Brent Park	647	524	681
437	863	Elm Park	351	341	348
1787	864	Clitterhouse Playing Fields	1480	1431	1746
1333	865	West Hendon Playing Fields	1191	1063	1049
13	866	Brent Hill Playing Fields	24	20	25
820	867	Cophall Playing Fields	1521	959	733
385	868	Montrose Playing Fields	900	918	1064
4	869	Burton Hole Lane Playing Fields	9	4	9
482	870	Mote Mount Open Space	618	543	1015
8	871	Arrandene Open Space	8	5	8
3	872	Colindeep Lane Open Space	282	378	33
590	873	Scratchwood Open Space	478	448	483
303	874	Hendon Grove	325	315	335
403	875	The Mill Field	320	352	375
662	876	Harman Drive Open Space	—	—	—
—	877	North Circular Road Playing Fields	350	—	—
250	878	Deacons Hill Open Space	10	49	50
—	879	Equipment of Children's Playgrounds	—	44	—
1503	880	Riverside Walks	1283	1091	1295
1827	881	Nurseries Account	1564	1437	1491
—	882	Purchase of Petrol Rollers and Tractors	750	713	600
124	883	Parks Motor Van and Car Allowance	164	164	164
1902	884	Open Spaces, etc., on Highways	1872	1894	2083
2223	885	Allotments	2400	2425	2600
<u>£30226</u>			<u>£31165</u>	<u>£29554</u>	<u>£31174</u>

For Loan Charges see Finance, etc.,
Committee Estimates.

ESTATES, PARKS AND ALLOTMENTS COMMITTEE

ESTIMATES OF INCOME, 1939/40.

Income 1937/38. £	Item.	Income.	Approved Estimate 1938/39. £	Approx. Income 1938/39. £	Estimate for 1939/40. £
HENDON PARK.					
554	886	Tennis Court Fees	520	607	650
40	887	Rent of Cricket Pitches	40	37	40
145	888	Putting Green Fees	140	126	140
2	889	Lavatory Fees	3	3	3
5	890	Privilege—Chairs	5	5	5
25	891	Privilege—Refreshments	18	5	15
1	892	Insurance—Refreshment Kiosk	1	1	1
—	893	Miscellaneous	8	—	—
<u>£772</u>			<u>£735</u>	<u>£784</u>	<u>£854</u>
CHILD'S HILL PARK.					
80	894	Tennis Court Fees	75	92	90
53	895	Bowling Green Fees	55	52	55
5	896	Privilege—Refreshments	5	5	5
2	897	Miscellaneous	5	1	5
<u>£140</u>			<u>£140</u>	<u>£150</u>	<u>£155</u>
SUNNY HILL PARK.					
144	898	Tennis Court Fees	140	145	140
31	899	Putting Green Fees	30	27	30
25	900	Rent of Cricket Pitches	40	39	40
4	901	Lavatory Fees	5	4	5
—	902	Privilege—Chairs	5	—	5
25	903	Privilege—Refreshments	15	—	15
1	904	Insurance—Refreshment Kiosk	1	—	1
—	905	Miscellaneous	5	—	5
<u>£230</u>			<u>£241</u>	<u>£215</u>	<u>£241</u>
MILL HILL PARK.					
192	906	Tennis Court Fees	200	212	215
126	907	Bowling Green Fees	150	128	220
143	908	Miniature Golf—Fees	140	165	175
42	909	Rents—Cricket Pitches	40	41	40
16	910	Rents—Football Pitches	15	12	15
13	911	Rents—Hockey Pitches	13	13	13
—	912	Rents—Lacrosse Pitches	5	—	5
1	913	Rents—Lands	1	1	1
7	914	Lavatory Fees	10	6	10
1	915	Privilege—Refreshments	5	5	5
—	916	Privilege—Chairs	5	—	5
—	917	Miscellaneous	5	—	—
<u>£541</u>			<u>£589</u>	<u>£583</u>	<u>£704</u>
PRINCES PARK.					
150	918	Tennis Court Fees	140	141	140
4	919	Lavatory Fees	4	4	4
—	920	Miscellaneous	5	2	5
<u>£154</u>			<u>£149</u>	<u>£147</u>	<u>£149</u>

ESTATES, PARKS AND ALLOTMENTS COMMITTEE (Contd.).

Income 1937/38. £	Item.	Income.	Approved Estimate 1938/39. £	Approx. Income 1938/39. £	Estimate for 1939/40. £
BASING HILL PARK.					
116	921	Tennis Court Fees	110	119	120
33	922	Putting Green Fees	40	43	45
6	923	Rents—Cricket Pitches	5	13	13
11	924	Lavatory Fees	12	12	12
2	925	Easement	2	2	2
—	926	Privilege—Refreshments	2	2	2
<u>£168</u>			<u>£171</u>	<u>£191</u>	<u>£194</u>
WATLING PARK.					
89	927	Tennis Court Fees	85	90	100
54	928	Putting Green Fees	55	46	50
—	928a	Bowling Green Fees	—	—	20
25	929	Rent of Refreshment Kiosk	10	—	15
1	930	Insurance—Refreshment Kiosk	1	—	1
2	931	Repairs to Kiosk	—	—	—
<u>£171</u>			<u>£151</u>	<u>£136</u>	<u>£186</u>
WOODCROFT PARK.					
8	932	Rents—Football Pitches	—	2	5
—	933	Rents—Cricket Pitches	—	1	5
—	934	Lavatory Fees	—	—	10
<u>£8</u>			<u>—</u>	<u>£3</u>	<u>£20</u>
WOODFIELD PARK.					
—	935	Rent of Cottages	—	51	94
75	936	Rent of Nursery Ground (Transfer)	75	75	75
33	937	Rent—Football Pitches	35	34	35
2	938	Privilege—Refreshments	3	3	—
15	939	Demolition of Woodfield House	—	—	—
<u>£125</u>			<u>£113</u>	<u>£163</u>	<u>£204</u>
EDGWAREBURY PARK.					
33	940	Rents—Cricket Pitches	30	33	35
42	941	Rents—Football Pitches	35	39	40
—	942	Lavatory Fees	—	—	5
<u>£75</u>			<u>£65</u>	<u>£72</u>	<u>£80</u>
DEANSBROOK PARK.					
£2	943	Privilege—Refreshments	—	—	—
STONEGROVE PARK.					
161	*944	Tennis Court Fees	155	171	175
28	945	Putting Green Fees	30	28	30
6	946	Lavatory Fees	10	9	10
—	947	Miscellaneous	5	—	5
<u>£205</u>			<u>£200</u>	<u>£208</u>	<u>£220</u>

ESTATES, PARKS AND ALLOTMENTS COMMITTEE (Contd.).

Income 1937/38. £	Item.	Income.	Approved Estimate 1938/39. £	Approx. Income 1938/39. £	Estimate for 1939/40. £
CLITTERHOUSE PLAYING FIELDS.					
90	948	Tennis Court Fees	90	106	110
74	949	Rents—Cricket Pitches	80	84	85
30	950	Rents—Hockey Pitches	30	36	40
142	951	Rents—Football Pitches	130	120	120
175	952	Rents—Golders Green Football Club	175	175	175
—	953	Rents—Allotment Land (Transfer)	13	—	—
7	954	Privilege—Refreshments	15	15	15
2	955	Lavatory Fees	5	5	10
2	956	Miscellaneous	5	3	—
<u>£522</u>			<u>£543</u>	<u>£544</u>	<u>£555</u>
WEST HENDON PLAYING FIELDS.					
43	957	Tennis Court Fees	40	49	50
61	958	Rents—Cricket Pitches	60	66	70
118	959	Rents—Football Pitches	120	117	120
5	960	Lavatory Fees	5	4	5
2	961	Privilege—Refreshments	5	5	5
18	962	Rent of Open Air Bath Site (Transfer)	18	18	18
—	963	Miscellaneous	5	—	—
<u>£247</u>			<u>£253</u>	<u>£259</u>	<u>£268</u>
COPTHALL PLAYING FIELDS.					
65	964	Rents—Football Pitches	55	75	80
—	965	Rents—Cricket Pitches	40	27	30
—	966	Rents—Lacrosse Pitches	—	3	5
13	967	Rents—Land for Grazing	—	—	—
—	968	Miscellaneous	5	1	—
<u>£78</u>			<u>£100</u>	<u>£106</u>	<u>£115</u>
MONTROSE PLAYING FIELDS.					
—	969	Tennis Fees	50	27	50
24	970	Rents—Cricket Pitches	38	65	75
—	971	Rents—Football Pitches	52	41	50
—	972	Privilege—Refreshments	—	1	—
—	973	Lavatory Fees	—	3	5
<u>£24</u>			<u>£140</u>	<u>£137</u>	<u>£180</u>
BURTON HOLE PLAYING FIELDS.					
£4	974	Grazing Rights	£5	—	—
MOTE MOUNT OPEN SPACE.					
2400	975	Rent—Mote Mount Golf Club	2400	2400	2400
5	976	Fishing Permits	5	6	5
128	977	Grazing Rights and Miscellaneous	120	120	120
<u>£2533</u>			<u>£2525</u>	<u>£2526</u>	<u>£2525</u>

ESTATES, PARKS AND ALLOTMENTS COMMITTEE (Contd.).

Income 1937/38. £	Item.	Income.	Approved Estimate 1938/39. £	Approx. Income 1938/39. £	Estimate for 1939/40. £
ARRANDENE OPEN SPACE.					
<u>£18</u>	978	Grazing Rights	<u>£20</u>	—	—
SCRATCHWOOD OPEN SPACE.					
<u>—</u>	979	Grazing Rights	<u>£40</u>	—	—
HENDON GROVE.					
13	980	Rent of Cottage	13	9	—
—	981	Grazing Rights, etc.	5	—	—
—	982	Miscellaneous	—	2	—
<u>£13</u>			<u>£18</u>	<u>£11</u>	—
THE MILL FIELD.					
9	983	Rents—Hockey and Lacrosse Pitches	12	10	10
11	984	Rents—Cricket Pitches	5	—	—
<u>£20</u>			<u>£17</u>	<u>£10</u>	<u>£10</u>
DEACONS HILL OPEN SPACE.					
<u>£122</u>	985	Rent	<u>£163</u>	<u>£165</u>	<u>£169</u>
RIVERSIDE WALKS.					
<u>£12</u>	986	Rent of Land, etc.	<u>£5</u>	<u>£5</u>	<u>£5</u>
NURSERIES ACCOUNT.					
<u>£1027</u>	987	Trees and Plants supplied to Parks, etc.	<u>£1100</u>	<u>£1000</u>	<u>£1100</u>

ESTATES, PARKS AND ALLOTMENTS COMMITTEE (Contd.).

Income 1937/38. £	Item.	Income.	Approved Estimate 1938/39. £	Approx. Income 1938/39. £	Estimate for 1939/40. £
OPEN SPACES, ETC., ON HIGHWAYS.					
Rent of Land:—					
30	988	Hendon Way	31	30	30
15	989	Police Hut (Hartley Avenue)	15	15	15
1	990	Albert Road (Mill Hill)	1	1	1
—	991	Tennyson Road (Mill Hill)	—	1	1
6	992	Renters Avenue	6	6	6
28	993	Allotments (Transfer)	13	28	25
57	994	Mill Hill Fire Station (Transfer)	57	57	57
7	995	Public Convenience, Mill Hill (Transfer)	7	7	7
5	996	Branch Library (Transfer)	11	11	11
2	997	Mill Hill Clinic (Transfer)	6	6	6
—	998	Harman Drive Open Space	—	25	20
3	999	Miscellaneous	5	5	5
£164			£152	£192	£184

ALLOTMENTS.

£882	1000	Rents	£700	£950	£975
------	------	-------------	------	------	------

SUMMARY OF COMMITTEE INCOME.

772	1001	Hendon Park	735	784	854
140	1002	Child's Hill Park	140	150	155
230	1003	Sunny Hill Park	241	215	241
541	1004	Mill Hill Park	589	583	704
154	1005	Princes Park	149	147	149
168	1006	Basing Hill Park	171	191	194
171	1007	Watling Park	151	136	186
8	1008	Woodcroft Park	—	3	20
125	1009	Woodfield Park	113	163	204
75	1010	Edwarebury Park	65	72	80
2	1011	Deansbrook Park	—	—	—
295	1012	Stonegrove Park	200	208	220
522	1013	Clitterhouse Playing Fields	543	544	555
247	1014	West Hendon Playing Fields	253	259	268
78	1015	Copthall Playing Fields	100	106	115
24	1016	Montrose Playing Fields	140	137	180
4	1017	Burton Hole Lane Playing Fields	5	—	—
2523	1018	Mote Mount Open Space	2525	2526	2525
18	1019	Araudene Open Space	20	—	—
—	1020	Scratchwood Open Space	40	—	—
13	1021	Hendon Grove	18	11	10
20	1022	The Mill Field	17	10	—
122	1023	Deacons Hill Open Space	163	165	169
12	1024	Riverside Walks	5	5	5
1027	1025	Nurseries Account	1100	1000	1100
164	1026	Open Spaces, etc., on Highways	152	192	184
882	1027	Allotments	700	950	975
£8257			£8335	£8557	£9093

ESTATES, PARKS AND ALLOTMENTS COMMITTEE

ESTIMATES, 1938/39 AND 1939/40—SUMMARY—DISSECTION OF EXPENDITURE.

WAGES, MATERIALS, TEAM LABOUR, ETC. (see page 38)	Estimate 1938/39. £	Estimate 1939/40. £
	22397	22876
SPECIAL ITEMS.—		
Conversion of Tennis Courts.—		
Watling Park	60	
West Hendon Playing Fields	90	
	150	
Spraying Tennis Courts.—		
Hendon Park	—	100
Stonogrove Park	70	—
	70	100
Fencing Works.—		
Hendon Park	60	—
Sunny Hill Park	150	45
Princes Park	—	18
Watling Park	50	32
Colindale Park	—	10
Woodcroft Park	—	50
Woodfield Park	55	—
Brent Park	60	80
Elm Park	—	20
Clitterhouse Playing Fields	—	25
Mote Mount Open Space	50	—
Deacons Hill Open Space	—	25
Riverside Walks	175	175
	600	478
Lay-out Schemes.—		
Mill Hill Park	—	100
Bittacy Park	400	—
York Park	131	131
Courtway	57	57
	588	288
Making-up Frontages.—		
Riverside Walks	70	
Uphill Drive	120	
	190	
Purchase of Mowers and Cutting Units.—		
Silkstream Park	52	—
West Hendon Playing Fields	52	—
Cophall Open Space	193	—
Open Spaces on Highways	—	37
	297	37
Shelters.—		
Watling Park	—	150
Clitterhouse Playing Fields	—	150
		300
Purchase of Petrol Rollers	750	—
Purchase of Tractors	—	600
Removing Rifle Range	250	—
Refreshment Kiosk—Clitterhouse Playing Fields	20	10
Purchase of Land	600	—
Construction of Footbridge—Riverside Walks	100	375
Clearing and Levelling—Riverside Walks	400	200
Tree Nursery	100	—
Bandstand—Watling Park	—	400
Water Supply—Brent Park	—	25
Water Supply and Latrines—Mote Mount	—	500
Lighting Pavilion—Montrose Park	—	45
New Greenhouse	—	—
Equipment of Children's Playgrounds	—	—
Allotments	2400	2600
OTHER ITEMS	2253	2340
TOTAL ESTIMATES	£31165	£31174

Estimate
1939/40.
£
22878

ESTATES, PARKS AND ALLOTMENTS

ESTIMATES, 1938/39 AND 1939/40—DISSECTION OF EXPENDITURE

Account.	Wages.		Materials (Grounds, Courts and Buildings).		Council's Team Labour.		Hired Lorries and Team Labour.		Work Petrol 1938/39.
	1938/39.	1939/40.	1938/39.	1939/40.	1938/39.	1939/40.	1938/39.	1939/40.	
	£	£	£	£	£	£	£	£	£
Hendon Park	1199	1239	120	75	140	20	38	50	16
Child's Hill Park	480	497	39	78	10	10	17	17	30
Sunny Hill Park	1104	1147	73	91	10	5	17	20	20
Mill Hill Park	930	1008	96	88	5	5	17	25	10
Princes Park	480	479	70	37	20	18	12	15	3
Basing Hill Park	469	485	53	70	10	5	17	18	30
Watling Park	1413	1490	70	73	10	10	77	55	10
Colindale Park	277	276	26	25	15	15	6	6	3
Bittacy Hill Park	250	240	—	20	—	—	20	15	5
York Park	277	266	13	23	25	25	6	6	5
Woodcroft Park	462	453	23	37	5	5	12	12	20
Silkstream Park	461	454	16	27	60	45	12	10	5
Woodfield Park	331	290	5	18	5	5	6	5	5
Edgwarebury Park	455	449	20	13	—	—	10	10	145
Lyndhurst Park	266	268	5	8	—	—	38	20	5
Stonegrove Park	636	655	28	41	—	—	22	25	35
Brent Park	459	458	35	30	5	5	12	12	—
Elm Park	277	270	21	16	—	—	6	10	2
Clitterhouse Playing Fields	1130	1193	70	98	5	—	12	15	120
West Hendon Playing Fields	714	740	45	55	10	—	12	12	30
Brent Hill Playing Fields	15	16	—	—	5	5	2	2	—
Copthall Playing Fields	469	455	20	28	—	—	12	12	35
Montrose Playing Fields	699	722	17	63	—	8	11	15	10
Burton Hole Lane Playing Fields	5	5	—	—	—	—	—	—	—
Mote Mount Open Space	464	454	20	22	30	10	12	10	5
Arrandene Open Space	5	5	—	—	—	—	—	—	—
Colindeep Lane Open Space	208	25	10	—	—	—	12	—	10
Scratchwood Open Space	448	446	5	10	—	—	6	6	—
Hendon Grove	266	271	15	15	—	—	8	8	5
The Mill Field	266	260	7	14	—	—	28	50	—
Deacons Hill Open Space	5	15	5	5	—	—	—	5	—
Riverside Walks	448	444	20	25	—	—	12	12	—
Nurseries Account	1018	943	185	197	5	10	25	25	—
Open Spaces, etc., on Highways	1265	1551	40	40	10	10	125	120	—
	£17651	17867	1172	1340	385	216	622	623	564

100

478

288

37

300

680

10

375

290

400

25

500

45

2600

2340

E31174

ESTATES, PARKS AND ALLO

ESTIMATES, 1938/39 AND 1939/40—SUMMA

WAGES, MATERIALS, TEAM LABOUR, ETC. (see page 28) 37

SPECIAL ITEMS.—

Conversion of Tennis Courts.—

Watling Park
West Hendon Playing Fields

Spraying Tennis Courts.—

Hendon Park
Stonegrove Park

Fencing Works.—

Hendon Park
Sunny Hill Park
Princes Park
Watling Park
Colindale Park
Woodcroft Park
Woodfield Park
Brent Park
Elm Park
Clitterhouse Playing Fields
Mote Mount Open Space
Deacons Hill Open Space
Riverside Walks

Lay-out Schemes.—

Mill Hill Park
Bittacy Park
York Park
Courtway

Making-up Frontages.—

Riverside Walks
Uphill Drive

Purchase of Mowers and Cutting Units.—

Silkstream Park
West Hendon Playing Fields
Copthall Open Space
Open Spaces on Highways

Shelters.—

Watling Park
Clitterhouse Playing Fields

Purchase of Petrol Rollers

Purchase of Tractors

Removing Rifle Range

Refreshment Kiosk—Clitterhouse Playing Fields

Purchase of Land

Construction of Footbridge—Riverside Walks

Clearing and Levelling—Riverside Walks

Tree Nursery

Bandstand—Watling Park

Water Supply—Brent Park

Water Supply and Latrines—Mote Mount

Lighting Pavilion—Montrose Park

New Greenhouse

Equipment of Children's Playgrounds

Allotments

OTHER ITEMS

TOTAL ESTIMATES

ESTATES, PARKS AND ALLO

ESTIMATES, 1938/39 AND 1939/40—DISSE

Pages.	Materials (Grounds, Courts and Buildings).		Council's Team Labour.		Hired Lorries and Team Labour.	
	1938/39.	1939/40.	1938/39.	1939/40.	1938/39.	1939/40.
	£	£	£	£	£	£
	1239	120	75	140	20	38
	497	39	78	10	10	17
	1147	73	91	10	5	17
	1008	96	88	5	5	17
	479	70	37	20	18	17
	485	53	70	10	5	17
	1490	70	73	10	10	77
	276	26	25	15	15	6
	240	—	20	—	—	20
	266	13	23	25	25	6
	453	23	37	5	5	12
	454	16	27	60	45	12
	290	5	18	5	5	6
	449	20	13	—	—	10
	268	5	8	—	—	38
	655	28	41	—	—	22
	458	35	30	5	5	12
	270	21	16	—	—	6
	1193	70	96	5	—	12
	740	45	55	10	—	12
	18	—	—	5	5	2
	455	20	28	—	—	12
	722	17	63	—	8	11
	5	—	—	—	—	—
	454	20	22	30	10	12
	5	—	—	—	—	—
	25	10	—	—	—	12
	446	5	10	—	—	6
	271	15	15	—	—	8
	260	7	14	—	—	28
	15	5	5	—	—	—
	444	20	25	—	—	12
	943	185	197	5	10	25
	1551	40	40	10	10	125
	17967	1172	1340	385	216	622
						623

PARKS AND ALLOTMENTS COMMITTEE

1938/39 AND 1939/40 - DISSECTION OF EXPENDITURE.

Council's Team Labour. 1938/39 AND 1939/40.	Hired Ladies and Team Labour. 1938/39. 1939/40.		Work Done by Petrol Rollers. 1938/39. 1939/40.		Motor Tractor and Mowing Units. 1938/39. 1939/40.		Shrubs, Plants and Seeds. 1938/39. 1939/40.		Tools and Plant (includ- ing Repairs). 1938/39. 1939/40.		Totals.	
	£	£	£	£	£	£	£	£	£	£	£	£
20	38	50	16	130	15	10	225	255	20	22	1773	1801
10	17	17	30	30	10	10	45	40	7	7	638	689
5	17	20	20	10	140	125	40	20	15	20	1419	1438
5	17	25	10	25	100	105	20	20	15	20	1193	1296
18	12	15	3	3	5	5	30	30	5	14	625	601
5	17	18	30	30	5	5	45	45	10	12	639	670
10	77	55	10	30	10	10	150	140	24	25	1764	1833
15	6	6	3	3	—	—	5	3	2	3	334	331
—	20	15	5	3	—	3	—	20	10	5	285	306
25	6	8	5	5	3	3	3	3	5	5	337	336
5	12	12	20	20	10	10	45	40	8	8	585	585
45	12	10	5	5	3	3	35	40	12	10	604	594
5	6	5	5	10	5	10	—	—	5	5	362	343
—	10	10	145	150	5	5	—	2	8	8	643	637
—	33	20	5	40	—	3	10	5	5	5	329	347
—	22	25	35	35	5	5	120	115	10	10	856	886
5	12	12	—	—	3	3	40	20	5	5	559	533
—	6	10	2	2	3	3	20	15	5	5	334	321
—	12	15	120	30	10	70	10	10	17	22	1374	1436
—	12	12	30	15	80	95	5	5	12	12	908	934
—	—	—	—	—	—	—	—	—	—	—	22	23
5	2	2	—	—	—	—	—	—	—	—	576	575
—	12	12	35	45	20	25	—	—	20	10	857	873
—	11	15	10	110	80	10	30	30	10	15	5	5
8	—	—	—	—	—	—	—	—	—	—	538	506
—	12	10	5	5	—	—	—	—	7	5	5	5
10	—	—	—	—	—	—	—	—	—	—	270	30
—	12	—	10	—	20	—	—	—	10	5	465	468
—	6	6	—	—	—	—	—	—	6	6	312	312
—	8	8	5	3	2	2	10	8	6	5	310	340
—	28	50	—	2	—	2	3	3	6	9	10	25
—	—	5	—	—	—	—	—	—	—	—	513	513
—	12	12	—	10	—	5	25	10	8	7	1323	1255
—	25	25	—	—	5	5	70	60	15	15	1630	1929
10	125	120	—	3	15	20	150	145	25	40	—	—
10	—	—	—	—	—	—	—	—	—	—	—	—
216	622	623	564	754	554	552	1136	1084	313	340	*92397	*22876

* see page 36.

Estates, Parks and Allotments Committee

SUMMARY AND NOTES ON ESTIMATES, 1939/40.

OUTLAY.				No.	DETAILS.	INCOME.				COMPARISON
1937/38	1938/39	1938/39	1939/40			1937/38	1938/39	1938/39	1939/40	Outlay
Actual.	Estimate.	Approx.	Estimate.			Actual.	Estimate.	Approx.	Estimate.	Decrease. In
1.	2.	3.	4.						9.	
£	£	£	£			£	£	£	£	
2273	2055	2049	2160	1	Hendon Park	772	735	784	854	—
727	730	738	795	2	Child's Hill Park	140	140	150	155	—
1705	1641	1602	1582	3	Sunny Hill Park	230	241	215	241	20
1450	1311	1333	1481	4	Mill Hill Park	541	589	583	704	—
538	656	589	649	5	Princes Park	154	149	147	149	—
690	683	689	732	6	Basing Hill Park	168	171	191	194	—
2071	2079	2062	2658	7	Watling Park	171	151	136	186	—
391	359	306	363	8	Colindale Park	—	—	—	—	—
38	696	765	333	9	Bittacy Hill Park	—	—	—	—	432
493	503	506	512	10	York Park	—	—	—	—	77
558	611	564	659	11	Woodcroft Park	8	—	3	20	—
672	681	701	624	12	Silkstream Park	—	—	—	—	—
513	598	567	478	13	Woodfield Park	125	113	163	204	89
619	666	631	669	14	Edgwarebury Park	75	65	72	80	—
291	372	325	359	15	Lyndhurst Park	—	—	—	—	—
514	—	26	—	16	Deansbrook Park	2	—	—	—	26
882	977	983	933	17	Stonegrove Park	205	200	268	220	50
700	647	524	681	18	Brent Park	—	—	—	—	—
437	351	341	348	19	Elm Park	—	—	—	—	—
1787	1480	1431	1746	20	Clitterhouse Playing Fields	522	513	544	555	—
1333	1191	1063	1049	21	West Hendon Playing Fields	247	253	259	268	14
13	24	20	25	22	Brent Hill Playing Fields	—	—	—	—	—
820	1521	959	733	23	Copthall Playing Fields	78	100	106	115	226
385	900	918	1064	24	Montrose Playing Fields	24	140	137	180	—
4	9	4	9	25	Burton Hole Playing Fields	4	5	—	—	—
482	618	543	1015	26	Mote Mount Open Space	2533	2525	2526	2525	—
8	8	5	8	27	Arrandene Open Space	18	20	—	—	—
3	282	378	33	28	Colindeep Lane Open Space	—	—	—	—	345
590	478	448	483	29	Scratchwood Open Space	—	40	—	—	—
303	325	315	335	30	Hendon Grove	13	18	11	—	—
403	320	352	375	31	The Mill Field	29	17	10	10	—
663	—	—	—	32	Harman Drive Open Space	—	—	—	—	—
—	350	—	—	33	North Circular Road Playing Fields	—	—	—	—	—
290	10	49	50	34	Deacons Hill Open Space	122	163	165	169	—
—	—	44	—	35	Equipment of Children's Playgrounds	—	—	—	—	44
1503	1283	1091	1295	36	Riverside Walks	12	5	5	5	—
1827	1564	1437	1491	37	Nurseries Account	1027	1100	1000	1100	—
—	759	713	600	38	Purchase of Petrol Rollers and Tractors	—	—	—	—	113
124	164	164	164	39	Parks Motor Van and Car Allowance	—	—	—	—	—
1903	1872	1894	2083	40	Open Spaces, etc., on Highways	164	152	192	184	—
2223	2400	2425	2600	41	Allotments	882	700	950	975	—
30226	31165	29554	31174			£8257	£8335	£8557	£9093	£1348
8257	8335	8557	9093	42	Deduct Income	—	—	—	—	—
£21369	£22830	£20997	£22081	43	Balance—Rate Charge	—	—	—	—	—

MEMORANDA.

The above table shows an estimated nett increased Rate Charge of £1,084. This increase is mainly due to the following items: Bandstand and Shelter at Watling Park (£550); Shelter at Clitterhouse Playing Fields (£150); Water at Mote Mount Open Space (£500); Footbridges at Riverside Walks (£375); and Sandy Minor Nett Interest (£109). Recurring items of expenditure which now disappear from the Estimates are, Lay-out of Bittacy Hill Park (£300) and Frontage—Colindale Park (£365).

SUMMARY

1939/40 Estimate	No.	DETAILS.
4.		
£		
2160	1	Hendon Park
795	2	Child's Hill Park
1582	3	Sunny Hill Park
1481	4	Mill Hill Park
649	5	Princes Park
732	6	Basing Hill Park
2658	7	Watling Park
363	8	Colindale Park
333	9	Bittacy Hill Park
512	10	York Park
659	11	Woodcroft Park
624	12	Silkstream Park
478	13	Woodfield Park
669	14	Edgwarebury Park
359	15	Lyndhurst Park
—	16	Deansbrook Park
933	17	Stonegrove Park
681	18	Brent Park
348	19	Elba Park
1746	20	Clitterhouse Playing Fields.....
1049	21	West Hendon Playing Fields.....
25	22	Brent Hill Playing Fields.....
733	23	Copthall Playing Fields
1064	24	Montrose Playing Fields
9	25	Burton Hole Playing Fields.....
1015	26	Mote Mount Open Space
8	27	Arrandene Open Space
33	28	Colindeep Lane Open Space
483	29	Scratchwood Open Space
335	30	Hendon Grove
375	31	The Mill Field
—	32	Harman Drive Open Space.....
—	33	North Circular Road Playing Fields
50	34	Deacons Hill Open Space
—	35	Equipment of Children's Playgrounds
1295	36	Riverside Walks
1491	37	Nurseries Account
600	38	Purchase of Petrol Rollers and Tractors
164	39	Parks Motor Van and Car Allowance
2083	40	Open Spaces, etc., on High- ways
2600	41	Allotments
31174		
9093	42	Deduct Income
£22081	43	Balance—Rate Charge

The above table shows an estimated nett increase for Bandstand and Shelter at Watling Park (£500); Footbridges at Mote Mount Open Space (£500); Footbridges and recurring items of expenditure which now disappear Proutage—Colindale Park (£365).

Estates, Parks and Allotments Committee

SUMMARY AND NOTES ON ESTIMATES, 1939/40.

No.	DETAILS.	INCOME.				COMPARISON 1939/40 ESTIMATES WITH 1938/39 RESULTS.						
		1937/38	1938/39	1938/39	1939/40	Outlay.		Income.		Rate Charge.		
		Actual.	Estimate.	Approx.	Estimate.	Decrease.	Increase.	Decrease.	Increase.	Decrease.	Increase.	
		5.	6.	7.	8.	9.	10.	11.	12.	13.	14.	
1	Hendon Park	£	£	£	£	£	£	£	£	£	£	
2	Child's Hill Park	772	735	784	854	—	111	—	70	—	41	
3	Sunny Hill Park	140	140	150	155	—	57	—	5	—	52	
4	Mill Hill Park	230	241	215	241	20	—	—	26	46	—	
5	Princes Park	541	589	583	704	—	148	—	121	—	27	
6	Basing Hill Park	154	149	147	149	—	60	—	2	—	58	
7	Watling Park	168	171	191	194	—	43	—	3	—	40	
8	Colindale Park	171	151	136	186	—	596	—	50	—	546	
9	Bitney Hill Park	—	—	—	—	—	57	—	—	—	57	
10	York Park	—	—	—	—	432	—	—	—	—	—	
11	Woodcroft Park	—	—	—	—	77	—	—	—	432	—	
12	Silkstream Park	8	—	3	20	—	—	—	—	77	—	
13	Woodfield Park	—	—	—	—	—	6	—	—	—	6	
14	Edgwarebury Park	125	113	163	204	89	—	—	17	—	76	
15	Lynnhurst Park	75	65	72	80	—	—	—	41	139	—	
16	Deansbrook Park	—	—	—	—	—	38	—	8	—	39	
17	Stonegrove Park	2	—	—	—	—	34	—	—	—	34	
18	Brent Park	205	200	208	220	26	—	—	—	26	—	
19	Elm Park	—	—	—	—	50	—	—	12	62	—	
20	Clitterhouse Playing Fields	522	543	544	555	—	157	—	—	—	157	
21	West Heaton Playing Fields	247	253	259	268	—	7	—	—	—	7	
22	Brent Hill Playing Fields	—	—	—	—	14	315	—	11	—	304	
23	Cupthall Playing Fields	78	100	106	115	—	5	—	9	23	—	
24	Montrose Playing Fields	24	140	137	180	226	—	—	9	235	5	
25	Burton Hole Playing Fields	4	5	—	—	—	146	—	43	—	103	
26	Note Mount Open Space	2533	2525	2526	2525	—	5	—	—	—	5	
27	Arrandene Open Space	18	20	—	—	—	472	1	—	—	473	
28	Colindeep Lane Open Space	—	—	—	—	—	3	—	—	—	3	
29	Scratchwood Open Space	—	40	—	—	345	—	—	—	345	—	
30	Hendon Grove	13	18	11	—	—	35	—	—	—	35	
31	The Mill Field	20	17	10	10	—	20	11	—	—	31	
32	Harman Drive Open Space	—	—	—	—	—	23	—	—	—	23	
33	North Circular Road Playing Fields	—	—	—	—	—	—	—	—	—	—	
34	Deacons Hill Open Space	122	163	165	169	—	—	—	—	—	—	
35	Equipment of Children's Playgrounds	—	—	—	—	44	—	—	4	3	—	
36	Riverside Walks	12	5	5	5	—	—	—	—	44	—	
37	Nurses' Account	1027	1100	1000	1100	—	204	—	—	—	204	
38	Purchase of Petrol Rollers and Tractors	—	—	—	—	113	54	—	100	46	—	
39	Parks Motor Van and Car Allowance	—	—	—	—	—	—	—	—	113	—	
40	Open Spaces, etc. on Highways	164	152	192	184	—	189	8	—	—	197	
41	Allotments	882	700	950	975	—	175	—	25	—	150	
		£8257	£8335	£8557	£9093	£1348	£3056	£20	£556	£1582	2666	
										Less	1582	
											Nett Increase 1939/40	£1084

MEMORANDA.

shows an estimated nett increased Rate Charge of £1,084. This increase is mainly due to provision being made for Shelter at Watling Park (£550); Shelter at Clitterhouse Playing Fields (£150); Water Supply and Latrines at Clitterhouse (£375); and Sundry Minor Nett Increases (£120). Non-provision for Footbridges at Riverside Walks (£500); Purchase of Petrol Rollers and Tractors (£500); and Purchase of Motor Van and Car (£200) which now disappear from the Estimates are, Lay-out of Bitney Hill Park (£546) and Making-up (£265).

Outlay
1937/38

4280

590

239

3

44

235

155

693

136

48

11

660

25

159

172

331

12

7802

175

189

123

124

£8413

23

1

31

£66

16

3

4

£24

PUBLIC HEALTH AND MEDICAL SERVICES COMMITTEE

ESTIMATES OF EXPENDITURE, 1939/40.

Outlay 1937/38. £	Item.	Expenditure.	Approved Estimate 1938/39. £	Approx. Outlay 1938/39. £	Estimate for 1939/40. £
SANITATION AND PREVENTION OF INFECTIOUS DISEASES.					
4289	1028	Salaries of Medical Officers, Sanitary Inspectors and Staff	4220	4142	4408
590	1029	Wages—Drivers, Drain Testers, etc.	580	631	637
239	1030	Superannuation and National Insurance	220	222	235
3	1031	Uniforms—Motor Drivers	10	11	10
44	1032	Printing M.O.H. Report	50	48	50
235	1033	Printing, Stationery and Postages	210	226	230
155	1034	Disinfectants and Appliances	140	154	150
693	1035	Notifications and Fees for Tests	480	695	700
136	1036	Car Allowances and Travelling Expenses, etc. (proportion)	190	204	210
48	1037	Filing, Record, Office Equipment and Furniture	25	22	25
11	1038	Telephone Service—M.O.H.	10	10	10
—	1039	Compensation—Damaged Clothing, Bed- ding, etc.	10	—	10
660	1040	Rent of Rooms—Town Hall	660	660	660
25	1041	Conference Expenses	60	77	60
159	1042	Diphtheria Immunisation	275	177	500
172	1043	Treatment of Verminous Premises	200	254	200
331	1044	Expenses under Housing Act, 1936	300	218	110
12	1045	Carriage and Sundries	5	5	5
7802			7645	7756	8210
MOTOR VEHICLES—MAINTENANCE, UPKEEP AND DEPRECIATION.					
175	1046	Austin Car (DMK 516)	160	151	160
189	1047	Austin Van (CMH 716)	170	181	170
123	1048	Infectious Diseases Ambulance No. 1	130	131	135
124	1049	Infectious Diseases Ambulance No. 2	125	132	135
£8413			£8230	£8351	£8810
DISEASES OF ANIMALS ACT ACCOUNT.					
25	1050	Salaries (Proportion)	25	25	25
1	1051	Superannuation Contribution	1	1	1
34	1052	Compensation, Veterinary Fees, etc.	—	10	4
—	1053	Printing and Stationery	—	—	—
£60			£26	£36	£30
MORTUARY.					
160	1054	Wages—Repairs and Upkeep	161	163	161
5	1055	Materials—Repairs and Upkeep	5	2	5
35	1056	Rates, Taxes and Insurance	35	40	44
40	1057	Water, Gas and Electricity	40	42	40
2	1058	Cleaning Sundries	2	1	2
£242			£243	£248	£252

PUBLIC HEALTH AND MEDICAL SERVICES COMMITTEE (Contd.).

Outlay 1937/38. £	Item.	Expenditure.	Approved Estimate 1938/39. £	Approx. Outlay 1938/39. £	Estimate for 1939/40. £	Outlay 1937/38. £
ISOLATION HOSPITAL.						
4316	1059	Salaries of Medical, Nursing, Domestic Staff and Chief Engineer	4600	4920	5000	2040
1649	1060	Wages of Stokers, Drivers, Porters and Attendants	1814	1825	1816	147
315	1061	Superannuation and National Insurance—Staff	335	346	366	£2187
162	1062	Uniforms and Overalls	100	110	120	
2029	1063	Provisions and Comestibles—Patients and Staff	2000	2274	2260	
563	1064	Furniture, Bedding, Linen, Hardware and Crockery	200	260	275	2178
171	1065	Cleaning Sundries	160	156	169	1512
450	1066	Drugs, Patent Foods, Medicines, Dressings, Instruments, etc.	425	557	550	2
1254	1067	Fuel	1300	1482	1466	£3722
429	1068	Gas and Electricity	410	507	475	
147	1069	Water	150	158	150	
724	1070	Rates, Taxes and Insurance	735	774	775	
55	1071	Telephone Service	52	52	52	73
105	1072	Printing, Stationery and Postages ..	85	82	85	84
151	1073	Electrical Fittings, Repairs and Maintenance	50	59	60	453
149	1074	Repairs and Upkeep of Buildings—Wages	160	165	169	—
172	1075	Repairs and Upkeep of Buildings—Materials, etc.	100	100	100	105
42	1076	Repairs to Plant, Machinery and Tools ..	40	56	50	202
373	1077	Renewals Fund (Plant and Machinery) ..	373	373	373	—
456	1078	Upkeep of Grounds and Gardens—Wages ..	475	482	485	270
137	1079	Upkeep of Grounds and Gardens—Other Items	120	116	120	£1188
21	1080	Haymaking and Grass Cutting	35	47	35	—
31	1081	Carriage, Travelling Expenses and Sundries	50	42	50	350
246	1082	Re-decorations	300	115	200	19
—	1083	Asphalte Contract (Paths, etc.)	—	84	—	—
—	1084	Drainage Work	—	217	—	200
—	1085	Fire Alarm Control	15	24	—	—
173	1086	Alteration to Sanitary Arrangements ..	—	—	—	£569
—	1087	Electric Sewing Machine	—	24	—	—
14320			14084	15347	15081	—
—	1088	Messroom, Ash-pit, etc.	100	—	100	—
387	1089	Sterilizing Plant and Surgical Lighting—Operating Theatre	—	—	—	529
299	1090	Fees—Special Operations and Consultations	300	320	330	23
—	1091	Oxygen Tent Service	—	25	25	6
£15006			£14484	£15702	£15536	116
MATERNITY AND CHILD WELFARE.						
Medical, Administrative and Health Visiting Services.						
2451	1092	Salaries of Medical Officer and Staff	4106	4604	4841	11
170	1093	Superannuation and National Insurance ..	221	236	248	11
59	1094	Uniforms—Health Visitors (proportion) ..	52	48	52	9
154	1095	Fares and Expenses	160	160	160	5
320	1096	Rent of Rooms—Town Hall	330	330	330	36
351	1097	Printing, Stationery and Postages	300	368	325	107
—	1098	Typewriters and Office Appliances	—	58	15	—
£4545			£5169	£5804	£5971	162
						6
						£1026

PUBLIC HEALTH AND MEDICAL SERVICES COMMITTEE (Contd.).

Outlay 1937/38. £	Item.	Expenditure.	Approved Estimate 1938/39. £	Approx. Outlay 1938/39. £	Estimate for 1939/40. £
MATERNITY AND CHILD WELFARE (Continued).					
Health Centres.					
2040	1099	Upkeep of Centres (Details page 45)	2035	2072	2091
147	1100	Medical Requisites and Dressings	70	85	100
<u>£2187</u>			<u>£2105</u>	<u>£2157</u>	<u>£2191</u>
Milk, Drugs, Dried Milk, etc.					
2178	1101	Drugs, Dried Milk, etc., for Sale	1800	2100	2150
1542	1102	Assisted Milk Supply	1300	1480	1550
2	1103	Carriage and Sundries	8	5	8
<u>£3722</u>			<u>£3108</u>	<u>£3585</u>	<u>£3708</u>
Special Treatment and Hospital Provision.					
73	1104	Orthopædic Defects (Hospital)	50	264	200
84	1105	Orthopædic Defects (Centres)	50	80	80
453	1106	Dental Defects—Dental Staff	280	273	357
—	1107	Dental Defects—Other Items	215	245	250
—	1108	Visual Defects	20	—	20
106	1109	Convalescent Treatment	25	100	100
202	1110	Treatment of Puerperal Fever and Ophthalmia Neonatorum	115	75	100
—	1111	Consultations, etc.—Complicated Labour	10	8	10
270	1112	Hospital Provision (Maternity)	200	323	260
<u>£1188</u>			<u>£965</u>	<u>£1368</u>	<u>£1317</u>
Voluntary Associations.					
350	1113	Contribution to Day Nursery	350	350	350
19	1114	Day Nursery—Upkeep of Buildings	20	5	20
—	1115	Day Nursery—Decorations	—	60	—
200	1116	Grant to Nursing Associations	200	200	300
<u>£569</u>			<u>£570</u>	<u>£615</u>	<u>£670</u>
Midwives Acts (including 1936 Act).*					
—	1117	Salary of Medical Officer (proportion)	73	73	75
—	1118	Salary of Inspector of Midwives	64	64	66
529	1119	Salaries of Midwives	1076	999	1359
—	1120	Salaries of Clerical Staff	42	43	45
23	1121	Superannuation and National Insurance	75	61	80
6	1122	Compensation to Midwives—Loss of Fees	20,	6	—
116	1123	Midwives for Necessitous Women	—	55	—
—	1124	Rent Allowance	75	52	78
11	1125	Uniforms	42	96	60
11	1126	Travelling Expenses	40	90	100
9	1127	Telephone Service	43	32	45
5	1128	Drugs, Dressings and Appliances	50	48	50
5	1129	Laundry	25	20	25
36	1129	Laundry	25	57	25
36	1130	Printing, Stationery and Postages	25	99	100
107	1131	Doctors' Fees (Medical Aid Notes)	100	150	200
—	1132	Watling Nursing Association	190	167	750
162	1133	Compensation (Loss of Practice)	—	—	—
6	1134	Sundries	—	—	—
<u>£1026</u>			<u>£1940</u>	<u>£2112</u>	<u>£3052</u>

* Part year only, 1938/39.

PUBLIC HEALTH AND MEDICAL SERVICES COMMITTEE (Contd.).

Outlay 1937/38. £	Item.	Expenditure.	Approved Estimate 1938/39. £	Approx. Outlay 1938/39. £	Estimate for 1939/40. £
Summary—Maternity and Child Welfare.					
4545	1135	Medical, Administrative and Health Visiting Service	5169	5804	5971
2187	1136	Health Centres	2105	2157	2191
3722	1137	Milk, Drugs, Dried Milk, etc.	3108	3585	3708
1188	1138	Special Treatment and Hospital Pro- vision	965	1368	1317
569	1139	Voluntary Associations	570	615	670
1026	1140	Midwives Acts	1940	2112	3052
£13237			£13857	£15641	£16909

SUMMARY OF COMMITTEE OUTLAY.

8413	1141	Sanitation, etc. (including Motor Vehicles)	8230	8351	8810
60	1142	Diseases of Animals Act Account	26	36	30
242	1143	Mortuary	243	248	252
15006	1144	Isolation Hospital	14484	15702	15536
13237	1145	Maternity and Child Welfare	13857	15641	16909
£36958			£36840	£39978	£41537

MATERNITY AND CHILD WELFARE—UPKEEP OF CENTRES
Details of Estimates of Expenditure

Outlay 1937-38.	Approximate Outlay 1938-39.	Expenditure.	Central Hendon.		Child's Hill.		West Hendon.		Wading Estate.		Mill Hill.		Edgware (Temporary).		Temple Fortune (Temporary).		Colindale (Temporary).		Woodside Park. (Temporary).		Total.		
			Estimates 1938-39	Estimates 1939-40	Estimates 1938-39	Estimates 1939-40	Estimates 1938-39	Estimates 1939-40	Estimates 1938-39	Estimates 1939-40	Estimates 1938-39	Estimates 1939-40	Estimates 1938-39	Estimates 1939-40	Estimates 1938-39	Estimates 1939-40	Estimates 1938-39	Estimates 1939-40	Estimates 1938-39	Estimates 1939-40	Estimates 1938-39	Estimates 1939-40	
£ 410	£ 466	Wages—Cleaning	133	70	64	68	116	120	69	75	—	—	—	—	—	—	—	—	—	—	—	£ 451	£ 464
120	135	Wages—Repairs and Upkeep	35	25	12	12	40	60	35	20	—	—	—	—	—	—	—	—	—	—	—	147	152
44	27	Materials, etc., Repairs	12	10	8	8	20	20	12	10	—	—	—	—	—	—	—	—	—	—	—	62	60
69	59	Laundry and Domestic Sundries	12	8	6	6	12	15	12	12	—	—	—	—	—	—	—	—	—	—	—	50	56
343	365	Electricity, Gas and Water	20	30	55	55	150	150	30	45	—	—	—	—	—	—	—	—	—	—	—	355	370
121	78	Furnishing and Equipment	10	10	10	10	20	15	10	10	—	—	—	—	—	—	—	—	—	—	—	18	78
527	599	Rents, Rates and Insurances	65	70	55	58	85	90	76	85	120	120	33	33	104	52	52	52	52	52	52	642	615
64	87	Telephone Service	—	20	15	14	20	20	15	15	—	—	—	—	—	—	—	—	—	—	—	70	89
83	150	Heating Plant (Transfer)	50	50	—	—	—	—	—	100	100	—	—	—	—	—	—	—	—	—	—	150	180
1781	1966		347	375	284	288	463	480	359	372	120	120	33	33	104	52	70	52	2005	2011	—	—	—
36	106	Decorations	30	15	—	15	—	20	—	15	—	—	—	—	—	—	—	—	—	—	—	30	80
151	—	Mill Hill Clinic—Equipment	—	—	—	—	—	—	—	—	—	—	—	—	—	—	—	—	—	—	—	—	—
34	—	Re-Decorations and Glass Screens	—	—	—	—	—	—	—	—	—	—	—	—	—	—	—	—	—	—	—	—	—
38	—	Opening Ceremony—Mill Hill	—	—	—	—	—	—	—	—	—	—	—	—	—	—	—	—	—	—	—	—	—
£2040	£2072		£377	£390	£284	£303	£225	£244	£103	£510	£359	£387	£120	£120	£33	£33	£104	£52	£70	£52	£2035	£2081	

Estimate for 1939-40. £
 5971
 2191
 3708
 1317
 670
 3052
 £16069
 8810
 30
 252
 15526
 16009
 £41337

PUBLIC HEALTH AND MEDICAL SERVICES COMMITTEE

ESTIMATES OF INCOME, 1939/40.

Income 1937/38. £	Item.	Income.	Approved Estimate 1938/39. £	Approx. Income 1938/39. £	Estimate for 1939/40. £
SANITATION AND PREVENTION OF INFECTIOUS DISEASES.					
628	1146	M.C.C. <i>re</i> Sanitary Officers' Salaries	1547	1538	1588
32	1147	Disinfections	50	30	50
38	1148	Drain Tests	40	29	40
5	1149	General	10	7	10
13	1150	Licences (Milk, Slaughterhouse, and Slaughtermen)	15	5	15
716			1662	1609	1703
MOTOR VEHICLES—PUBLIC HEALTH DEPARTMENT.					
2	1151	Infectious Diseases Ambulance—Fees...	5	2	5
—	1152	Cost of Repairs Recovered	5	—	—
£718			£1672	£1611	£1708
DISEASES OF ANIMALS ACT.					
£6	1153	Grant—Ministry of Agriculture and Fisheries	—	—	—
MORTUARY.					
—	1154	Fees	—	—	£10
ISOLATION HOSPITAL.					
2177	1155	Maintenance of Patients	1500	1985	2500
112	1156	Rents—Cottages	112	112	112
6	1157	Telephone	5	7	10
54	1158	Fees Recovered	—	250	250
10	1159	Miscellaneous	10	—	10
£2359			£1627	£2354	£2882
MATERNITY AND CHILD WELFARE.					
Health Centres.					
Rents Charged to Education Committee:—					
350	1160	Central Hendon Centre	350	350	350
200	1161	West Hendon Centre	200	200	200
220	1162	Child's Hill Centre	220	220	220
550	1163	Watling Centre	550	550	550
100	1164	Mill Hill Centre	400	400	400
5	1165	Miscellaneous	5	—	—
£1425			£1725	£1720	£1720
Milk, Drugs, Dried Milk, etc.					
£2550	1166	Sale of Drugs, Dried Milk, etc.	£1950	£2450	£2500

Income
1937/38.
£

6

103

6

6

£121

115

48

1

115

1

93

£374

£80

£2760

1425

2550

121

374

80

4550

2760

£7310

718

6

2350

7310

£10300

PUBLIC HEALTH AND MEDICAL SERVICES COMMITTEE (Contd.).

Income 1937/38. £	Item.	Income.	Approved Estimate 1938/39. £	Approx. Income 1938/39. £	Estimate for 1939/40. £
MATERNITY AND CHILD WELFARE (Continued).					
Treatment.					
6	1167	Orthopaedic Defects—Fees	5	30	20
103	1168	Dental Defects—Fees	100	166	160
—	1169	Anaesthetists Fees	1	2	5
6	1170	Convalescent Treatment—Fees	10	3	10
6	1171	Sundries	—	8	10
<u>121</u>			<u>116</u>	<u>209</u>	<u>205</u>
Midwives Acts.					
115	1172	Hospital Cases (Maternity)—Fees	80	100	100
48	1173	Obstetric Consultants' Fees and Fees for Doctors called in by Midwives.....	40	35	40
1	1174	Sterile Dressings and Accouchement Sets	10	8	20
115	1175	Midwives—Fees	540	260	600
1	1176	Midwives—Fees, Necessitous Cases	—	—	—
1	1177	Telephone Fees—Midwife	5	6	10
93	1178	Grant Receivable—Midwives Act, 1936:— (a) Compensation to Midwives on Surrender of Certificates	—	83	375
—	1179	(b) Provisional—for Increased Out- lay	190	200	250
<u>374</u>			<u>865</u>	<u>692</u>	<u>1395</u>
Voluntary Associations.					
£80	1180	Rent—Day Nursery	£80	£80	£80
Grant—Ministry of Health.					
£2760	1181	General Exchequer Grant	£2760	£2760	£2760
Summary—Maternity and Child Welfare.					
1425	1182	Health Centres	1725	1720	1720
2550	1183	Milk, Drugs, Dried Milk, etc.	1950	2450	2500
121	1184	Treatment	116	209	205
374	1185	Midwives Acts	865	692	1395
80	1186	Voluntary Associations	80	80	80
<u>4550</u>			<u>4736</u>	<u>5151</u>	<u>5900</u>
2760	1187	Grant—Ministry of Health	2760	2760	2760
<u>7310</u>			<u>7496</u>	<u>7911</u>	<u>8660</u>
SUMMARY OF COMMITTEE INCOME.					
718	1188	Sanitation and Prevention of Infectious Diseases	1672	1611	1708
6	1189	Diseases of Animals Act Account	—	—	10
—	1190	Mortuary	1627	2354	2882
2359	1191	Isolation Hospital	7496	7911	8660
7310	1192	Maternity and Child Welfare	—	—	—
<u>10303</u>			<u>10795</u>	<u>11876</u>	<u>13260</u>

Public Health and Medical Services Committee

SUMMARY AND NOTES ON ESTIMATES, 1939/40.

OUTLAY.		INCOME.				COMPARISON 1939/40 ESTIMATES WITH 1938/39 RESULTS.							
1937/38 Actual.	1938/39 Estimate.	1938/39 Estimate.	1938/39 Approx.	1939/40 Estimate.	Outlay.		Income.		Rate Charge.				
1.	2.	3.	4.	5.	6.	7.	8.	9.	10.	11.	12.	13.	14.
£	£	£	£	£	£	£	£	£	£	£	£	£	£
8443	8230	8351	8810	718	1672	1611	1708	—	459	—	97	—	362
69	26	36	30	6	—	—	—	6	—	—	—	6	—
242	243	248	252	—	—	—	10	—	4	—	10	6	—
15695	14484	15702	15536	2359	1627	2354	2882	166	—	—	528	694	—
1227	13837	15641	16909	7310	7496	7911	8660	—	1268	—	749	—	519
23928	36349	39378	41537	£10393	£10795	£11876	£13260	£172	£1731	—	£1384	£706	881
10363	10745	11476	13260					Deduct Income		Less			
226765	229015	228102	228277					Balance—Rate Charge		Nett Increase 1939/40			
								£175					

Referer
to Tab
1
2
3
4
5

MEMORANDA.

Reference
to Table.

Head of Service.

1 **Sanitation and Prevention of Disease.—**

Increased provision for expenditure in connection with Diphtheria Immunisation.

2 **Diseases of Animals Acts.—**

No observations.

3 **Mortuary.—**

No observations.

4 **Isolation Hospital.—**

Decrease in rate charge mainly due to expected increase in income from other Authorities for maintenance of extra-district patients.

The Committee has made certain proposals as to the provision of a Surgical Unit, and has under consideration the question of residential accommodation for the Resident Medical Officer. No provision is made in this Committee's Estimates for any expenditure which might thereby be involved.

5 **Maternity and Child Welfare.—**

The principal increase is in connection with the service provided under the Midwives Acts, 1902-1936, which operates for a full year's charges in 1939/40 as against 8 months in 1938/39. Provision is also made for compensation claims pending in connection with the surrender of certificates by Midwives in private practice.

HIGHWAYS COMMITTEE

ESTIMATES OF EXPENDITURE, 1939/40.

Outlay 1937/38. £	Item.	Expenditure.	Approved Estimate 1938/39. £	Approx. Outlay 1938/39. £	Estimate for 1939/40. £
TRUNK AND COUNTY ROADS— GENERAL MAINTENANCE.					
8373	1193	Edgware Road (Trunk Road) (A. 5)	8399	8987	9298
5140	1194	Finchley Road (A. 598)	6092	5063	3769
2673	1195	Other Main Roads (A. 502)	4243	3610	3932
1125	1196	Cricklewood Lane (A. 407)	1422	1105	1216
17311			20156	18765	18215
281	1197	Finchley Lane (A. 5000)	478	392	422
1014	1198	The Broadway, Hale Lane and Lower Hale Lane (A. 5100)	1181	1333	1520
610	1199	Colindeep Lane and Queen's Road (B. 551)	885	850	910
1426	1200	The Ridgeway, Parson Street, etc. (B. 552)	2419	2387	2463
1627	1201	Deansbrook Road, Marsh Lane, etc. (B. 553)	2319	2300	2519
682	1202	Hendon Wood Lane (B. 554)	322	339	451
714	1203	Hammers Lane and Daws Lane (B. 5361)	629	625	687
33	1204	Dollis Road (B. 5362)	55	60	62
450	1205	Hale Lane and Station Road, Edgware (Agency Road) (A. 5100)	3583	3529	2167
£24148			£32027	£30580	£29416
TRUNK AND COUNTY ROADS— IMPROVEMENT WORKS.					
Finchley Road, A.598.—					
2124	1206	Improvement—Mutton Brook	—	—	—
—	1207	Stone Paving (Special Maintenance)	775	—	525
114	1208	Traffic Control—Cross Roads	—	250	—
Other Main Roads, A.502.—					
—	1209	Woodpaving and Dux Contract	850	850	850
—	1210	Stone Paving (Special Maintenance)	248	248	334
1308	1211	Improvement by Victoria Road	—	—	—
—	1212	Improvement, Burroughs, opposite " Fenella "	750	—	750
—	1213	Improvement by Woodlands	140	140	—
28	1214	Improvement by Elm Lodge	—	—	—
2735	1215	Church Road Widening	—	—	—
Colindeep Lane, B.551.—					
702	1216	Stonepaving	—	—	—
The Ridgeway, Parson Street, etc., B.552.—					
—	1217	Parson Street—Globe Crescent	750	—	—
7011		Carried forward	3513	1488	2459

Outlay
1937/3
£

7011

44

10

50

£7123

£63

6

2

2

19

8

1

£30

115

115

HIGHWAYS COMMITTEE (Contd.).

Outlay 1937/38. £	Item.	Expenditure.	Approved Estimate 1938/39. £	Approx. Outlay 1938/39. £	Estimate for 1939/40. £
TRUNK AND COUNTY ROADS— IMPROVEMENT WORKS (Continued).					
7011		Brought forward	3513	1488	2459
Deansbrook Road, Marsh Lane, etc., B.553.—					
—	1218	Marsh Lane, Hendon Wood Lane, etc., Footpaths	1250	—	1250
—	1219	Marsh Lane by Hylmary Cottage	50	—	50
—	1220	Stone Paving (Special Maintenance)	139	139	—
44	1221	Marsh Lane (corner of Highwood Hill)	—	—	—
Daws Lane, B.5381.—					
10	1222	Widening Forecourts	—	—	—
Hammers Lane, B.5361.—					
—	1223	Widening by "Three Hammors" P.H.....	—	1197	—
58	1224	Construction of Refuges	—	—	350
<u>£7123</u>			<u>£4952</u>	<u>£2824</u>	<u>£4109</u>
1225		TRUNK AND COUNTY ROADS— SUPERANNUATION CONTRIBUTIONS	£701	£631	£658
<u>£636</u>					
LOCAL HIGHWAYS AND STREETS— TARPAINTING.					
603	1226	Wages	730	757	760
268	1227	Hired Lorries and Team Labour	360	339	350
	1228	Council's Diesel Roller	—	52	50
205	1229	Hired Rollers	250	216	220
	1230	Fuel, Waste, etc.	25	28	30
1941	1231	Tar	2400	2244	2250
866	1232	Chippings, Sand, etc.	910	942	930
116	1233	Tools and Plant	138	137	138
<u>£3999</u>			<u>£4813</u>	<u>£4715</u>	<u>£4728</u>
LOCAL HIGHWAYS AND STREETS— MAINTENANCE AND SCAVENGING.					
11584	1234	Wages—Scavenging, Snow Removal, etc.	12435	13505	14279
11255	1235	Wages—General Maintenance, etc.	10584	10288	12652
13	1236	Council's Team Labour—Scavenging	50	10	20
79	1237	Council's Team Labour—Maintenance.....	200	12	25
<u>22931</u>		Carried forward	<u>23269</u>	<u>23815</u>	<u>26976</u>

HIGHWAYS COMMITTEE (Contd.).

Outlay 1937/38. £	Item.	Expenditure.	Approved Estimate 1938/39. £	Approx. Outlay 1938/39. £	Estimate for 1939/40. £	Outlay 1937/38. £
LOCAL HIGHWAYS AND STREETS— MAINTENANCE AND SCAVENGING (Continued).						
22931		Brought forward	23269	23815	26976	2329
733	1238	Hired Lorries and Team Labour— Scavenging	800	902	950	612
1891	1239	Hired Lorries and Team Labour— Maintenance	1950	1714	1900	16 41
10210	1240	Materials—Tarmac, Granite, Hardcore, Shingle, etc. (including flags for paths and minor improvements)	10337	8618	9878	1 8
230	1241	Council's Diesel Roller, Petrol Rollers, and Tractors	325	187	250	24 29
—	1242	Council's Bedford Lorries	—	132	200	—
558	1243	Hired Steam Rollers	550	554	560	£3060
—	1244	Hired Petrol Rollers	20	5	10	—
7	1245	Hire of Compressor	10	5	10	—
25	1246	Water	30	20	25	—
1120	1247	Tools, Plant and Repairs thereto	1176	1094	1257	—
1420	1248	Tarpaving and Other Repairs by Contractors	1050	451	850	7825
78	1249	Rent of Offices and Sheds at Depôts	78	44	59	236
660	1250	Gully Emptying by Motor Pump	675	568	600	27
7	1251	Sundries	—	3	5	2867
39870		Total—Ordinary Outlay	40270	38112	43530	207 78
—	1252	Making up Frontages — Devonshire Crescent	150	—	150	—
—	1252a	Making up Frontages—Southover	—	—	581	11240
525	1253	Making up Frontage — Wildwood Road (1/6th Cost) (Final Payment, 1940/41)	525	525	525	7737 990 34
1111	1254	The Vale Widening	1407	929	—	—
—	1255	Purchase of Bedford Lorry	—	308	—	5682
—	1256	Walmington Fold—S.W. Drain	—	271	100	—
—	1257	Park View Gardens—S.W. Drain	—	94	—	13
20	1258	Traffic Census	—	—	—	—
29	1259	Footpaths Improvement—Wise Lane	—	—	—	—
—	1260	Fencing—Abercorn Road	—	—	121	7
£41555			£42352	£40239	£45007	22
STREET TREES AND GRASS MARGINS (Local Highways).						
Street Trees.—						
1242	1261	Wages	1068	1378	1270	58 39
152	1262	Materials	149	294	200	—
65	1263	Council's Team Labour	58	—	—	—
409	1264	Hired Lorries and Team Labour	350	391	395	16
81	1265	Work done by Tractors and Mowing Units	75	140	145	1125
371	1266	Trees (including Felling and Lopping)	350	461	350	—
9	1267	Tools and Plant	10	13	10	70
2329		Carried forward	2060	2677	2370	27033

HIGHWAYS COMMITTEE (Contd.).

Outlay 1937/38. £	Item.	Expenditure.	Approved Estimate 1938/39. £	Approx. Outlay 1938/39. £	Estimate for 1939/40. £
STREET TREES AND GRASS MARGINS (Local Highways) (Continued).					
2329		Brought forward	2060	2677	2370
Grass Margins.—					
612	1268	Wages	573	717	750
16	1269	Materials	60	42	50
41	1270	Hired Lorries and Team Labour	50	40	45
1	1271	Work done by Petrol Rollers	—	—	—
8	1272	Work done by Tractors and Mowing Units	5	12	10
24	1273	Tools and Plant (including Repairs)	10	12	12
29	1274	Purchase of Long Grass Mowers	—	—	45
£3060			£2758	£3500	£3282
STREET LIGHTING.					
Gas Light and Coke Co.'s Area.—					
7825	1275	2 light lamps—2011 lamps at £3 17s. 6d.	7905	7894	7792
236	1276	3 light lamps—115 lamps at £5 15s. 0d.	385	279	661
27	1277	4 light lamps—5 lamps at £6 17s. 6d.	28	35	34
2867	1278	6 light lamps—274 lamps at £8 10s. 0d. to £10 16s. 0d.	2869	2869	2964
207	1279	10 light lamps—14 lamps at £14 15s. 0d.	207	206	207
78	1280	12 light lamps—5 lamps at £15 10s. 0d.	78	77	78
—	1281	Improved Lighting	220	—	220
11240			11692	11360	11956
North Middlesex Gas Co.'s Area.—					
7737	1282	2 light lamps—1600 lamps at £4 14s. 0d.	7863	7620	7520
990	1283	3 light lamps—415 lamps at £5 14s. 0d.	1202	1538	2365
34	1284	4 light lamps (No. 2)—4 lamps at £7 8s. 0d. to £9 0s. 0d.	34	35	34
5682	1285	6 light lamps—134 lamps at £10 15s. 0d.) 6 light lamps—354 lamps at £12 0s. 0d.)	5688	5688	5688
—	1286	10 light lamps—65 lamps at £13 13s. 0d.	395	395	884
13	1287	2 light lamps (Rochester)—2 lamps at £6 5s. 0d.	12	12	13
—	1288	3 light Magnolux—2 lamps at £10 15s. 0d.	—	11	22
—	1289	Improved Lighting	393	—	486
7	1290	Brent Terrace Lighting (Gas Light and Coke Co.)	8	8	8
22	1291	Northway, etc., Lighting (Finchley Corporation)	22	22	22
25725			27309	26689	28998
Brent Hill Housing Estate.—					
58	1292	Electricity	58	58	58
39	1293	Maintenance (by Council)	35	32	35
Hendon Local Board Act, 1880—Gas Light and Coke Co.'s Area.—					
16	1294	12 light lamps—1 lamp at £15 10s. 0d.	16	16	16
1125	1295	6 light lamps—104 lamps at £10 16s. 0d.	1123	1124	1124
—	1296	Conversion of 20—6 light lamps to 12 light (half cost)	—	—	140
70	1297	Lighting "Osira" Lamps—Kingsbury Road	70	70	70
27033			28611	27989	30441
		Carried forward			

HIGHWAYS COMMITTEE (Contd.).

Outlay 1937/38. £	Item.	Expenditure.	Approved Estimate 1938/39. £	Approx. Outlay 1938/39. £	Estimate for 1939/40. £	Outlay 1937/38. £
STREET LIGHTING (Continued).						
27033		Brought forward	28611	27989	30441	
North Metropolitan Electric Power Supply Co.'s Area.—						
3109	1298	100 watt lamps— 20 lamps at £3 11s. 0d.	71	71	71	3
	1299	100 watt lamps—541 lamps at £4 0s. 0d.	1928	1975	2164	18
	1300	200 watt lamps— 2 lamps at £5 19s. 0d.	24	21	12	—
	1301	200 watt lamps— 9 lamps at £1 11s. 0d.	14	—	—	1
	1302	250 watt lamps— 98 lamps at £12 19s. 0d.	1269	—	—	—
	1303	250 watt lamps— 14 lamps at £10 0s. 0d.	140	1425	1448	22
	1304	65 watt lamps—Sodium—40 lamps at £5 4s. 6d. (average)	—	28	209	—
Renewals and Repairs.—						
239	1305	Lamps, Lanterns and Fittings	215	252	250	19
Extensions—New Streets and Roads.—						
200	1306	Lamp Columns	112	84	140	23
304	1307	Lamps, Lanterns, Fittings and Fixing....	350	462	450	1
Lullington Garth.—						
14	1308	Electricity and Maintenance	90	56	60	—
Improvement Schemes.—						
1438(Cr.)	1309	General Improvement Scheme—				£65
		Reinstatements, etc.	350	—	—	
	1310	Vivian Avenue—Columns, etc.	—	—	420	
£29461			£33174	£32363	£35665	10
STREET REFUGES AND TRAFFIC SIGNS—LOCAL ROADS (includ- ing Painted Lines).						
792	1311	Lighting Refuges (all Roads)	1020	920	1278	39
140	1312	General Maintenance (Refuges and Signs)	150	94	150	1
35	1313	Construction of New Refuges	200	486	250	1
3	1314	New Warning and Directional Signs	50	161	150	7
£970			£1420	£1661	£1828	—
" MAJOR ROAD AHEAD " SIGNS.						
Erection.—						
247	1315	County Roads (Class 1)	25	12	20	—
—	1316	County Roads (Class 2)	15	8	10	—
—	1317	Local Roads	—	12	15	—
247			40	32	45	—
Maintenance.—						
10	1318	County Roads (Class 1)	15	8	15	1075
1	1319	County Roads (Class 2)	—	—	5	—
—	1320	Local Roads	—	—	8	—
£258			£55	£40	£73	1075
SPEED LIMIT SIGNS.						
5	1321	County Roads	10	9	10	—
15	1322	Local Roads	5	3	5	—
£20			£15	£12	£15	1075

HIGHWAYS COMMITTEE (Contd.).

Outlay 1937/38. £	Item.	Expenditure.	Approved Estimate 1938/39. £	Approx. Outlay 1938/39. £	Estimate for 1939/40. £
PEDESTRIAN CROSSING PLACES (CONSTRUCTION).					
(a) County Roads.—					
3	1323	Wages	15	1	13
18	1324	Materials, Beacons and Studs	55	11	45
—	1325	Hired Lorries and Team Labour	5	1	2
1	1326	Tools, Plant and Sundries	1	—	—
<u>22</u>			<u>76</u>	<u>13</u>	<u>60</u>
PEDESTRIAN CROSSING PLACES (MAINTENANCE).					
(a) County Roads. (b) Local Roads.					
19	1327	Wages	10	8	15
23	1328	Materials, Beacons and Studs	40	25	40
1	1329	Hired Lorries and Team Labour	1	1	2
—	1330	Tools, Plant and Sundries	1	—	1
<u>£65</u>			<u>£128</u>	<u>£47</u>	<u>£118</u>
BARRIER RAILS (ERECTION).					
(a) County Roads. (b) Local Roads.					
10	1331	Wages	30	17	50
39	1332	Guard Rails and Materials	70	32	220
1	1333	Hired Lorries and Team Labour	2	2	5
1	1334	Tools, Plant and Sundries	2	—	—
<u>£51</u>			<u>£104</u>	<u>£51</u>	<u>£275</u>
PARKING PLACES.					
1	1335	Wages	5	1	5
7	1336	Materials	5	3	5
—	1337	Signs	15	2	15
1	1338	Sundries	—	—	—
<u>£9</u>			<u>£25</u>	<u>£6</u>	<u>£25</u>
TRAFFIC SIGNALS (AUTOMATIC AND TRAFFIC ACTUATED).					
Installation of Signals.—					
1075	1339	Parson Street (Church Road)	—	—	—
—	1340	Watling Avenue (Orange Hill Road)	870	926	—
—	1341	Golders Green Cross Roads	—	—	950
<u>1075</u>			<u>870</u>	<u>926</u>	<u>950</u>
Maintenance of Signals.—					
Golders Green Cross Roads:—					
—	1342	Electricity	—	—	15
—	1343	Contract Maintenance	—	—	26
—	1344	Insurance and Sundries	—	—	3
<u>1075</u>		Carried forward — — —	<u>870</u>	<u>926</u>	<u>994</u>

HIGHWAYS COMMITTEE (Contd.).

Outlay 1937/38. £	Item.	Expenditure.	Approved Estimate 1938/39. £	Approx. Outlay 1938/39. £	Estimate for 1939/40. £
TRAFFIC SIGNALS (AUTOMATIC AND TRAFFIC ACTUATED) (Continued).					
1075		Brought forward	870	926	994
Finchley Road (Cricklewood Lane):—					
19	1345	Electricity	20	20	20
44	1346	Contract Maintenance	44	44	44
3	1347	Insurance and Sundries	6	6	6
<u>1141</u>			<u>940</u>	<u>996</u>	<u>1064</u>
Parson Street (Church Road):—					
—	1348	Electricity	20	24	25
—	1349	Contract Maintenance	36	35	36
—	1350	Insurance and Sundries	5	5	6
<u>1141</u>			<u>1001</u>	<u>1060</u>	<u>1131</u>
Watling Avenue (Orange Hill Road):—					
—	1351	Electricity	10	12	40
—	1352	Contract Maintenance	18	16	26
—	1353	Insurance and Sundries	3	3	6
<u>1141</u>			<u>1032</u>	<u>1091</u>	<u>1203</u>
23	1354	Contributions (County Council Signals)	23	23	23
<u>£1164</u>			<u>£1055</u>	<u>£1114</u>	<u>£1226</u>

**PUBLIC CLOCKS (LIGHTING AND
MAINTENANCE).**

22	1355	Golders Green	20	20	20
4	1356	All Saints' School	4	4	4
<u>£26</u>			<u>£24</u>	<u>£24</u>	<u>£24</u>

STREET NAMING AND NUMBERING.

159	1357	Wages	183	234	200
57	1358	Materials	50	60	50
36	1359	Hired Lorries and Team Labour	28	45	35
239	1360	Name Plates	250	240	220
<u>£491</u>			<u>£511</u>	<u>£579</u>	<u>£505</u>

MILL HILL SUBWAY.

52	1361	Wages	276	78	65
37	1362	Materials			63
99	1363	Electricity			85
4	1364	Water and Sundries			6
<u>£192</u>			<u>£276</u>	<u>£232</u>	<u>£221</u>

HIGHWAYS COMMITTEE (Contd.).

Outlay 1937/38. £	Item.	Expenditure.	Approved Estimate 1938/39. £	Approx. Outlay 1938/39. £	Estimate for 1939/40. £
SUMMARY OF COMMITTEE OUTLAY.					
24148	1365	Trunk and County Roads—General Maintenance	32027	30580	29416
7123	1366	Trunk and County Roads—Improve- ments	4952	2824	4109
636	1367	Trunk and County Roads—Superannua- tion Contributions	701	631	658
31907		Total—Trunk Roads and County Roads	37680	34035	34183
3999	1368	Local Highways and Streets— Tarpainting	4813	4715	4728
41555	1369	Local Highways and Streets— Maintenance and Scavenging	42352	40239	45907
3060	1370	Street Trees and Grass Margins (Local Highways)	2758	3500	3282
29461	1371	Street Lighting	33174	32363	35665
970	1372	Street Refuges and Traffic Signs	1420	1661	1828
258	1373	“Major Road Ahead” Signs	55	40	73
20	1374	Speed Limit Signs	15	12	15
65	1375	Pedestrian Crossings Places	128	47	118
51	1376	Barrier Rails	104	51	275
9	1377	Parking Places	25	6	25
1164	1378	Traffic Signals	1055	1114	1226
26	1379	Public Clocks	24	24	24
491	1380	Street Naming and Numbering	511	579	505
192	1381	Mill Hill Subway	276	232	221
£113228			£124390	£118618	£127175
		For Loan Charges see Finance, etc., Committee Estimates.			

HIGHWAYS COMMITTEE

ESTIMATES OF INCOME, 1939/40.

Income 1937/38. £	Item.	Income.	Approved Estimate 1938/39. £	Approx. Income 1938/39. £	Estimate for 1939/40. £
31907	1382	Trunk Roads and County Roads	37680	34035	34183
82	1383	Local Roads—General	75	76	75
1264	1384	Trenches and Private Works (Surplus)	1000	1150	1000
1800	1385	Street Lighting and Harvist's and Lyons' Fund	1800	1850	1800
74	1386	Street Refuges and Signs	272	558	322
155	1387	“Major Road Ahead” Signs	31	16	28
14	1388	Speed Limit Signs	10	11	13
51	1389	Pedestrian Crossing Places	111	38	95
—	1390	Barrier Rails	69	31	156
5	1391	Parking Places	15	4	15
1135	1392	Traffic Signals	655	702	1167
—	1393	Mill Hill Subway	276	—	—
£36487			£41994	£38471	£38854

SUMMARY OF NETT EXPENDITURE.

113228	Expenditure	124390	118618	127175
36487	Income	41994	38471	38854
£76741	Nett Expenditure	£82396	£80147	£88321

(Items 1193 to 1205).

Details of Estimates for Trunk Roads and County Roads, 1939/40.

	Edgware Road (Trunk Road).	Finchley Road.	Other Main Roads.	Cricklewood Lane.	Finchley Lane.	Broadway, Hale Lane, etc.	Colindeep Lane and Queen's Road.	The Ridge-way, Parson Street, etc.	Deansbrook Road, Marsh Lane, etc.	Hendon Wood Lane.	Hammers Lane and Daws Lane.	Dollis Road.	Hale Lane and Station Road (Edgware).	Totals
	£	£	£	£	£	£	£	£	£	£	£	£	£	£
Scavenging, Gully Cleaning and Watering—														
Wages	821	605	915	385	70	300	230	445	545	60	100	16	285	477
Haulage and Team Labour	101	95	190	70	35	95	50	80	120	20	50	12	110	102
Gully Machine	79	40	70	25	8	15	14	25	12	—	8	3	6	30
Shoot	11	10	10	5	—	—	—	—	—	—	—	—	—	3
Snow Removal—														
Wages	159	200	150	75	20	70	65	170	200	30	70	5	100	131
Materials	53	60	65	30	8	10	15	55	45	5	15	1	40	40
Haulage	106	75	45	25	5	40	30	70	75	5	30	3	50	55
Shoot	11	10	10	8	3	5	5	10	5	—	5	1	5	5
Tools and Plant	21	17	22	9	3	9	6	13	15	3	5	1	9	13
Totals—Scavenging, etc.	£1362	£1112	£1477	£632	£152	£544	£415	£868	£1017	£123	£283	£42	£605	£863

(continued on page 59).

Details of Estimates for Trunk Roads and County Roads—continued.

	Edgware Road (Trunk Road).	Finchley Road.	Other Main Roads.	Cricklewood Lane.	Finchley Lane.	Broadway, Hale Lane, etc.	Colindeep Lane and Queen's Road.	The Ridge-way, Purson Street, etc.	Deansbrook Road, Marsh Lane, etc.	Uendon Wood Lane.	Hammers Lane and Daws Lane.	Dollis Road.	Hale Lane and Station Road (Edgware).	Total.
	£	£	£	£	£	£	£	£	£	£	£	£	£	£
Ordinary Maintenance.														
Wages	1749	700	700	150	50	200	120	265	370	70	75	10	160	4619
Materials	4119	1498	1094	300	90	202	152	394	426	145	112	8	280	8820
Haulage and Rolling	509	150	200	30	15	30	20	50	70	25	25	2	40	1166
Traffic Control, etc.	726	—	—	—	—	—	—	—	—	—	—	—	—	726
Heavy Plant	159	60	30	10	—	5	5	—	25	—	—	—	10	304
Tools and Plant	7262	2408	2024	490	155	437	297	709	891	240	212	20	490	15635
Contract Work	102	36	30	7	3	7	5	10	13	5	3	—	7	228
	212	—	—	—	50	450	100	500	400	—	100	—	1000	2812
Tarpainting	7576	2444	2054	497	208	894	402	1219	1304	245	315	20	1497	18675
	360	213	401	87	62	82	93	376	198	83	89	—	65	2109
Total Maintenance	£7936	£2657	£2455	£584	£270	£976	£495	£1595	£1502	£328	£404	£20	£1562	£20784
Summary.														
Scavenging, etc.	1362	1112	1477	632	152	544	415	868	1017	123	283	42	605	8632
Maintenance	7576	2444	2054	497	208	894	402	1219	1304	245	315	20	1497	18675
Tarpainting	360	213	401	87	62	82	93	376	198	83	89	—	65	2109
Totals	£9298	£3769	£3932	£1216	£422	£1520	£910	£3463	£2519	£451	£687	£62	£2167	£29416

Highways Committee

SUMMARY AND NOTES ON ESTIMATES, 1939/40.

OUTLAY.				INCOME.				COMPARISON 1939/40 ESTIMATES WITH 1938/39 RESULTS.						
1937/38		1938/39		1938/39		1939/40		1937/38		1938/39		1939/40		
Actual.	Estimate.	Approx.	Estimate.	Actual.	Estimate.	Approx.	Estimate.	Actual.	Estimate.	Decrease.	Increase.	Decrease.	Increase.	
				No. DETAILS.				Outlay.		Income.		Rate Charge.		
								£	£	£	£	£	£	
1.	2.	3.	4.					9.	10.	11.	12.	13.	14.	
				Trunk Roads and County Roads:—				£	£	£	£	£	£	£
				Local Highways and Streets:—				£	£	£	£	£	£	£
24148	32027	30580	29416	1	General Maintenance			1164	—	1164	—	—	—	
7123	4952	2824	4109	2	Improvement Works			—	1285	—	1285	—	—	
636	701	651	658	3	Superannuation Contributions			—	27	—	27	—	—	
3909	4813	4715	4728	4	Tarpainting			—	13	—	—	—	13	
41555	42352	40239	45007	5	Maintenance & Scavenging			—	4768	1	—	—	4769	
—	—	—	—	6	Trenches and Private Works (Surplus)			—	—	150	—	—	150	
3960	2758	3500	3282	7	Street Trees & Grass Margins			218	—	—	—	218	—	
29461	32174	32363	35665	8	Street Lighting			—	3302	50	—	—	3352	
970	1420	1661	1828	9	Street Refuges and Signs			—	167	236	—	—	403	
258	55	40	73	10	"Major Road Ahead" Signs			—	33	—	—	12	21	
29	15	12	15	11	Speed Limit Signs			—	3	—	—	2	1	
65	128	47	118	12	Pedestrian Crossing Places			—	71	—	—	37	14	
51	104	51	275	13	Barrier Rails			—	224	—	—	125	99	
9	25	6	25	14	Parking Places			—	19	—	—	11	8	
1164	1655	1114	1226	15	Traffic Signals			—	112	—	—	465	353	
26	24	24	24	16	Public Clocks			—	74	—	—	—	—	
491	511	579	505	17	Street Naming & Numbering			—	11	—	—	—	—	
192	276	232	221	18	Mill Hill Subway			—	—	—	—	—	—	
113228	124390	118618	127175	19	Deduct Income			£1407	£10024	£1601	£1984	£656	£830	
36487	41904	34471	38854	20	Balance—Rate Charge			—	—	—	—	Less	656	
£79741	£82396	£80147	£88321					Nett Increase 1939/40		£8174				

18
17
16
15
14
13
12
11
10
9
8
7
6
5
4
3
2
1
 Before to Tab

MEMORANDA.

Reference
to Table.

Head of Service.

1/3 **Trunk and County Roads.—**
No observations.4 **Local Highways and Streets—Tarpainting.—**
No observations.5 **Local Highways—Maintenance and Scavenging.—**

The estimated increase is due mainly to extra mileage of new streets taken over. In the year 1937/38 approximately 6 miles of private streets were dedicated as highways repairable by the public. The following is a summary of the increases as compared with the outlay for 1938/39:—

	£
Wages, etc.	3138
Transport	357
Rolling, etc.	79
Tools and Plant	163
Materials	1260
Sundries	23
	<hr/>
Contract Work	5020
	399
	<hr/>
	5419
Less Saving on Special Works	650
	<hr/>
	£4769

6 **Trenches and Private Works.—**
No observations.7 **Street Trees and Grass Margins.—**

Decrease due to exceptional work in connection with replacement of street trees carried out in 1938/39, not recurring.

8 **Street Lighting.—**

Increase due to scheme of improving standard of street lighting in various parts of the district and the incidental increase in upkeep costs. Provision is also made for lighting new streets and roads.

9 **Street Refuges and Signs.—**

Increase for lighting and maintenance of refuges and conversion of concrete guard posts to illuminated bollards.

10 **"Major Road Ahead" Signs.—**
No observations.11 **Speed Limit Signs.—**
No observations.12 **Pedestrian Crossing Places.—**
No observations.13 **Barrier Rails.—**

Provision for erection of Barrier Rails at Golders Green Cross Roads, part cost of which falls upon the Corporation.

14 **Parking Places.—**
No observations.15 **Traffic Signals.—**

Increased income in respect of cost of Traffic Signals at Golders Green Cross Roads wholly recoverable from County Council and Ministry of Transport.

16 **Public Clocks.—**
No observations.17 **Street Naming and Numbering.—**
No observations.18 **Mill Hill Subway.—**
No observations.

AIR RAID PRECAUTIONS COMMITTEE

AIR RAID (FIRE) PRECAUTIONS.

ESTIMATES OF EXPENDITURE, 1939/40.

Outlay 1937/38. £	Item.	Expenditure.	Approved Estimate 1938/39. £	Approx. Outlay 1938/39. £	Estimate for 1939/40. £
		Administration and Staff.—			
—	1394	Additional Staff		—	440
—	1395	Printing, Stationery and Postages		49	25
		Storage and Training Accommodation.—			
—	1396	Floodlighting Yards		43	—
—	1397	Structural Alterations, Repairs and Decorations		25	200
—	1398	Rents and Upkeep of Premises		5	510
		Recruitment, Equipment and Training.—			
—	1399	Medical Examination Fees, etc.		98	87
—	1400	Uniforms, Overalls, etc.		1429	1600
—	1401	Instructors' Fees	5000	220	630
—	1402	Insurance of Personnel		45	60
		Emergency Appliances and Equipment.—			
—	1403	Running Expenses		10	40
—	1404	New Appliances and Equipment		110	450
		Vehicles.—			
—	1405	Hire of Vehicles		—	100
		Other Expenses.—			
—	1406	Telephone Service		10	30
—	1407	Bonus to Auxiliary Firemen		40	660
—	1408	Sundries		10	18
			5000	2094	4850
		Income.			
—	1409	Home Office Grant—60 per cent.	3000	1256	2910
		Balance—Rate Charge	£2000	£838	£1940

MEMORANDA.

The nett rate charge shows a decrease of £60 (£2,000, less £1,940). The items are self-explanatory and do not call for any special observations.

AIR RAID (GENERAL) PRECAUTIONS.

ESTIMATES OF EXPENDITURE, 1939/40.

Expenditure.	Approx. Outlay 1938/39.		Estimate for 1939/40. £
	Routine. £	Crisis. £	
Instruction of and Advice to Public	29	—	125
Air Raid Warnings	—	—	100
Reports re Casualties	—	—	100
Air Raid Wardens	15	—	100
First Aid, etc., Services	115	605	400
Rescue and Decontamination Work	50	185	500
Gas Detection	—	—	50
Repair Services	—	—	500
Recruitment and Training	1311	148	2600
Protection of Premises	—	391	500
Shelters and Trenches	—	16923	3000
Lighting of Highways	—	160	1000
Respirators—Distribution	—	340	150
Equipment—Storage and Maintenance	349	21	765
Other Expenses	100	—	200
Administration	1900	—	2310
		18773	
Less Surplus Timber, etc.	—	6120	—
Balance—M.C.C. Charge	£3869	£12653	£12400

MEMORANDA.

The Middlesex County Council has provided, in the County Budget, a sum of £77,277 for nett expenditure on Air Raid (General) Precautions over the whole of the County. The Corporation's share is estimated at £7,145 and is included in the County Precept (page 86).

FINANCE AND GENERAL PURPOSES COMMITTEE

ESTIMATES OF EXPENDITURE, 1939/40.

Outlay 1937/38. £	Item.	Expenditure.	Approved Estimate 1938/39. £	Approx. Outlay 1938/39. £	Estimate for 1939/40. £
SALARIES ACCOUNT.					
5118	1410	Town Clerk's Department	5172	5225	5400
9610	1411	Treasurer's Department—General	9110	9321	9584
4997	1412	Treasurer's Department—Cost of Rate Collection Account	5382	5519	5592
14481	1413	Engineer's Department	15328	15842	16605
2659	1414	Typists' Offices	2836	2914	3085
<u>£36865</u>			<u>£37828</u>	<u>£38821</u>	<u>£40266</u>
SUPERANNUATION CONTRIBUTIONS AND ALLOWANCES.					
£4226	1415	Rate Charge	£5070	£5127	£5316
LEGAL EXPENSES.					
352	1416	Solicitors' Costs and Counsels' Fees	400	329	400
1383	1417	Costs—Rate Summonses	1300	1370	1400
<u>£1735</u>			<u>£1700</u>	<u>£1699</u>	<u>£1800</u>
TOWN HALL.					
2058	1418	Wages—Caretakers, Cleaners, Tele- phonist, and Hall Porters	2062	2203	2230
281	1419	Fuel	300	310	300
385	1420	Gas and Electricity	360	388	390
75	1421	Water	80	62	70
1201	1422	Rates, Taxes and Insurance	1270	1357	1405
184	1423	Cleaning and Domestic Sundries	160	190	190
96	1424	Upkeep of Buildings—Wages	200	172	200
97	1425	Upkeep of Buildings—Other Items	100	152	100
422	1426	Telephone Service	420	420	420
15	1427	Uniforms—Hall Porters	12	10	12
68	1428	Electrical Fittings, Inspections and Repairs	65	75	65
291	1429	Decorations	220	421	220
26	1430	Towel Service	26	26	26
154	1431	Furnishing	100	118	100
6	1432	Sundries	25	10	15
77	1433	Renewals Fund (Heating Plant)	77	77	77
<u>£5526</u>			<u>£5477</u>	<u>£5991</u>	<u>£5820</u>
"FENELLA," THE BURROUGHS.					
42	1434	Wages (Contingent)	50	34	—
11	1435	Sundries	10	8	—
<u>£53</u>			<u>£60</u>	<u>£42</u>	<u>—</u>
CHURCH ROAD PROPERTIES.					
18	1436	Cost of Demolition	—	—	—
—	1437	Rates, Taxes and Insurances (Wingfield Cottages)	36	—	36
<u>£18</u>			<u>£36</u>	<u>—</u>	<u>£36</u>

imate
for
9/40.
£

440
25

200
510

87
600

630
60

40
450

100

30
660

18

4550

2910

1940

nd do not

imate
for
30/40.
£

125
100

100
100

400
500

50
500

2000
500

3000
1000

150
765

200
2310

400

iture on
145 and

FINANCE AND GENERAL PURPOSES COMMITTEE (Contd.).

Outlay 1937/38. £	Item.	Expenditure.	Approved Estimate 1938/39. £	Approx. Outlay 1938/39. £	Estimate for 1939/40. £
THE BURROUGHS PROPERTY.					
£425	1438	Purchase Money (Balance—Methodist Trustees)	—	—	—
RAVENSFIELD HOUSE.					
3	1439	Insurances	3	3	3
81	1440	Upkeep of Building (including Care-taker's Wages)	80	105	100
123	1441	Rates, Water, Gas and Electricity	130	132	140
£207			£213	£240	£243
INSURANCES AND STAMP DUTY.					
Insurance Premiums:—					
692	1442	Workmen's Compensation	700	—*	—*
331	1443	Third Party and Public Liability	280	435	450
103	1444	Fidelity Guarantee	80	100	100
31	1445	Cash in Transit	60	43	50
—	1446	Loss of Rent	36	41	41
2	1447	Personal Accident	17	13	17
1	1448	Miscellaneous Insurances	8	5	5
195	1449	Special Insurance—Coronation Celebrations (Council's Fund)	—	—	—
1355			1181	637	663
102	1450	National Health Insurance	180	186	190
Stamp Duty:—					
350	1451	Audit Stamp Duty (Financial Statement)	250	500	500
208	1452	Cheques, Agreements, Contracts, etc.	230	218	230
£2015		* Allocated to Sundry Accounts.	£1841	£1541	£1583
PRINTING, STATIONERY, ADVERTISING, POSTAGES, RECEIPT STAMPS, ETC.					
2018	1453	Printing, Stationery, Account Books, Statutory Notices, Advertising, Periodicals and Publications	2200	2151	2200
242	1454	Maps and Lithography	250	280	300
888	1455	Minutes, Agendas, and Abstract of Accounts	1000	986	1000
1430	1456	Postage and Receipt Stamps	1550	1448	1500
£4578			£5000	£4865	£5000
OFFICIAL MOTOR CARS AND CYCLES (Working Accounts, including Depreciation).					
351	1457	Surveyor's Austin 12 Car (including Driver) H.M.K. 915	364	362	370
375	1458	Surveyor's Wolseley 14 Car (including Driver) K.M.D. 930	375	393	406
344	1459	Surveyor's Austin 12 Car (including Driver) H.M.X. 998	345	365	370
170	1460	Surveyor's Rover 14 Car, H.M.K. 911	186	190	195
364	1461	Treasurer's Austin 14 Car (including Driver) D.M.K. 515	363	374	337
210	1462	Treasurer's Wolseley 14 Car (including Driver) K.M.D. 932	225	222	240
4	1463	Assistant Foremen's Cycles	5	10	5
£1818			£1863	£1916	£1973

FINANCE AND GENERAL PURPOSES COMMITTEE (Contd.).

Outlay 1937/38. £	Item.	Expenditure.	Approved Estimate 1938/39. £	Approx. Outlay 1938/39. £	Estimate for 1939/40. £
OTHER EXPENSES.					
357	1464	Travelling Expenses and Conference Expenses	360	437	500
447	1465	Shops Acts and Street Trading Inspection	610	629	700
1236	1466	Office Appliances and Machinery	1000	1171	1000
57	1467	Local Inquiry Expenses	100	263	100
233	1468	Loan Costs	600	1375	850
544	1469	Election Expenses	500	584	500
931	1470	Valuation Expenses	350	427	450
500	1471	Mayor's Allowance	500	500	500
552	1472	Mayor's Car—Upkeep	520	521	520
13	1473	Ceremonials, etc.	—	119	—
1972	1474	Sundry Charges (including L.C.C. Commission for Rate Collection)	1500	1437	1500
<u>£6842</u>			<u>£6040</u>	<u>£7463</u>	<u>£6620</u>

LOAN CHARGES.

31827	1475	Sewerage and Sewage Disposal	30193	30238	29272
10013	1476	County Roads	10135	10276	11600
15116	1477	Local Roads	14946	14342	14630
—	1477a	Public Lighting	—	—	476
28774	1478	Parks and Pleasure Grounds	31672	31740	32382
6039	1479	Public Offices and Buildings	6173	6173	6369
1097	1480	Dépôts	1202	1272	1786
3368	1481	Fire Station and Appliances	3459	3459	3203
3673	1482	Disposal of House Refuse	3582	3582	3507
5775	1483	Hospital	5187	5187	5136
1393	1484	Maternity and Child Welfare	1576	1576	1542
662	1485	Public Conveniences	686	775	910
3726	1486	Baths and Washhouses	3880	3883	3873
52	1487	Mortuary	45	45	45
3492	1488	Public Libraries	3549	3549	3484
1192	1489	Allotments	823	863	853
<u>£116199</u>			<u>£117108</u>	<u>£116960</u>	<u>£119068*</u>

SUMMARY OF COMMITTEE OUTLAY.

36865	1490	Salaries Account	37828	38821	40266
4226	1491	Superannuation Contributions	5070	5127	5316
1735	1492	Legal Expenses	1700	1699	1800
5526	1493	Town Hall	5477	5991	5820
53	1494	"Penella," The Burroughs	60	42	—
18	1495	Church Road Properties	36	—	36
425	1496	The Burroughs Property	—	—	—
207	1497	Ravensfield House	213	240	243
2015	1498	Insurances and Stamp Duty	1841	1541	1583
4578	1499	Printing, Stationery, Postages, etc.	5000	4865	5000
1818	1500	Official Motor Cars	1863	1916	1973
6842	1501	Other Expenses	6040	7463	6620
64308			65128	67705	68637
116199	1502	Loan Charges	117108	116960	119068
<u>£180507</u>			<u>£182236</u>	<u>£184665</u>	<u>£187725</u>

* Includes provision for New Loans.

FINANCE AND GENERAL PURPOSES COMMITTEE

ESTIMATES OF INCOME, 1939/40.

Income 1937/38. £	Item.	Income.	Approved Estimate 1938/39. £	Approx. Income 1938/39 £	Estimate for 1939/40. £	Income 1937/38. £
SALARIES ACCOUNT.						
300	1503	Grant—Surveyor's Salary	300	300		321
1175	1504	Education Committee (Transfer)	1175	1175	300	2
14	1505	Miscellaneous Items	10	31	1450	32
		Fees Repaid by Sundry Officers:—			20	£355
56	1506	Registration Fees (Town Clerk)	65	63	65	
285	1507	Registration Fees (Treasurer)	240	257	260	
58	1508	Old Age Pension Fees (Town Clerk)	60	58	60	
1139	1509	County Roads Establishment—M.C.C.	1601	1529	1470	
1119	1510	Official Search Fees	1100	950	1100	84
531	1511	Supervision Charges—Special Private Works	—	—	—	—
<u>£4677</u>			<u>£4551</u>	<u>£4363</u>	<u>£4725</u>	<u>£84</u>
LEGAL EXPENSES.						
14	1512	General Legal Expenses Recovered	25	131	25	
1327	1513	Cost of Rate Summonses Recovered	1300	1370	1400	
22	1514	Stamp Duties—Private Improvement Expenses (Agreements)	30	14	20	
<u>£1363</u>			<u>£1355</u>	<u>£1515</u>	<u>£1445</u>	<u>£130</u>
TOWN HALL.						
155	1515	Fees for Hire of Rooms	200	200	200	
13	1516	Rent—Metropolitan Water Board	13	13	13	
25	1517	Inquest Fees	20	24	25	
6	1518	Telephone Fees Repaid	5	14	5	15
		Rent of Offices (Transfers):—				
1365	1519	Education Department	1365	1365	1365	16
		Public Health Department:—				
660	1520	Sanitation Account	660	660	660	
330	1521	Maternity and Child Welfare	330	330	330	£31
183	1522	Treasurer's Department (Rates Collection)	183	183	183	
100	1523	Treasurer's Department (Housing Section)	100	100	100	
59	1524	Rent of Garages at Rear of Town Hall (Transfer)	54	54	54	£47
50	1525	Heating Service—Central Hendon Clinic	50	50	50	
—	1526	Miscellaneous	5	2	5	
<u>£2046</u>			<u>£2985</u>	<u>£2995</u>	<u>£2990</u>	
ST. GEORGE'S HOUSE.						
£151	1527	Rent and Insurance	£151	£151	£151	1473 34
"FENELLA," THE BURROUGHS.						
£85	1528	Rents	£100	£100	£150	118 9 10 £1644

FINANCE AND GENERAL PURPOSES COMMITTEE (Contd.).

Income 1937/38. £	Item.	Income.	Approved Estimate 1938/39. £	Approx. Income 1938/39. £	Estimate for 1939/40. £
RAVENSFIELD HOUSE.					
321	1529	Rent of Rooms	259	272	252
2	1530	Insurances Recoverable	2	2	2
32	1531	Rent—Caretaker	32	42	65
<u>£355</u>			<u>£293</u>	<u>£316</u>	<u>£319</u>
BURROUGHS PARADE AND EGERTON GARDENS PROPERTIES.					
84	1532	Rent of Epworth Cottage	38	38	38
—	1533	Ground Rents	73	73	73
—	1534	Other Rents	—	1	1
<u>£84</u>			<u>£111</u>	<u>£112</u>	<u>£112</u>
CHURCH ROAD PROPERTIES (Wingfield Cottages).					
—	1535	Rents	£230	—	£230
INSURANCES AND STAMP DUTY.					
£130	1536	Stamp Duty, Postages, etc., Recovered	£115	£145	£150
PRINTING AND STATIONERY.					
15	1537	Sale of Bye-Laws, Maps, Plans and other Publications	15	10	15
16	1538	Sale of Copies of Council's Agenda	20	22	22
—	1539	Election Stationery	5	—	5
<u>£31</u>			<u>£40</u>	<u>£32</u>	<u>£42</u>
OFFICIAL CARS.					
£47	1540	Grant—Ministry of Transport re Sur- veyor's Car	£45	£45	£45
OTHER ITEMS.					
1473	1541	Bank Interest	1250	1450	1500
34	1542	Valuation Account, Copies of Lists, etc.	35	20	30
Licences:—					
118	1543	Petrol and Carbide Storage	120	131	130
9	1544	Sale of Game	10	9	10
10	1545	Street Trading	10	11	10
—	1546	Miscellaneous Income	10	—	10
<u>£1644</u>			<u>£1435</u>	<u>£1621</u>	<u>£1690</u>

Estimate
for
1939/40.
£306
1450
2665
280
60
1470
1100

£4725

25
1400

20

£1445

200
13
25
5

1365

660
330

183

100

54
50
5

£2000

£151

£150

FINANCE AND GENERAL PURPOSES COMMITTEE (Contd.).

Income 1937/38. £	Item.	Income.	Approved Estimate 1938/39. £	Approx. Income 1938/39. £	Estimate for 1939/40. £
LOAN CHARGES.					
8388	1547	County Roads per M.C.C.	10422	10569	11971
6868	1548	Sewage Works per M.C.C.	8966	8738	8226
484	1549	Housing Account, for Brent Hill Sites	484	484	484
11411	1550	Loan Charges re Unemployment Grant Schemes	10635	10635	10464
127	1551	Education Committee re Transferred Lands—Page Street School Site	127	127	127
23	1552	Subsidy—Housing Act, 1923	23	23	23
£27281			£30657	£30576	£31295

SUMMARY OF COMMITTEE INCOME.

4677	1553	Salaries Account	4551	4363	4725
1363	1554	Legal Expenses	1355	1515	1445
2946	1555	Town Hall	2985	2995	2990
151	1556	St. George's House	151	151	151
85	1557	"Fenella," The Burroughs	100	100	150
355	1558	Ravensfield House	293	316	319
84	1559	Burroughs Parade and Egerton Gardens Property	111	112	112
—	1560	Church Road Properties	230	—	230
130	1561	Insurances and Stamp Duty	115	145	150
31	1562	Printing and Stationery	40	32	42
47	1563	Official Cars	45	45	45
1644	1564	Other Items	1435	1621	1690
27281	1565	Loan Charges	30657	30576	31295
38794			42068	41971	43344
Rateable Refunds from County Council:—					
—	1566	re West Middlesex Drainage (Twickenham Review Order)	—	985	—
204	1567	re Diseases of Animals Acts	250	250	250
£38998			£42318	£43206	£43594

Estimate for 1939/40 2

11971
8226
484
10464
127
23
31295

4725
1445
2900
151
150
319

112
230
150
42
45
1690
1295
3344

250
3594

Finance and General Purposes Committee

SUMMARY AND NOTES ON ESTIMATES, 1939/40.

OUTLAY.			INCOME.										
1938/39		1939/40		COMPARISON 1939/40 ESTIMATES WITH 1938/39 RESULTS.									
Actual.	Estimate.	Approx.	Estimate.	DETAILS.									
1.	2.	3.	4.	5.	6.	7.	8.	9.	10.	11.	12.	13.	14.
£	£	£	£	£	£	£	£	£	£	£	£	£	£
36865	37828	38821	40266	1	4677	4551	4363	4725	—	1445	—	—	1083
4226	5070	5127	3316	2	—	—	—	—	—	189	—	—	180
1735	1700	1699	1800	3	1363	1355	1515	1445	—	101	70	—	171
5226	5477	5691	5820	4	2946	2985	2995	2990	171	—	—	166	—
53	60	42	—	5	151	151	151	151	—	—	—	—	—
18	36	—	—	6	85	100	100	150	42	—	50	92	—
425	—	—	36	7	—	230	—	230	—	36	230	194	—
207	213	240	—	8	84	111	112	112	—	—	—	—	—
2015	1841	1541	1583	9	355	293	316	319	—	3	3	—	—
4578	5090	4865	5000	10	139	115	145	150	—	42	5	—	37
1818	1863	1916	1973	11	31	40	32	42	—	135	10	—	125
6842	6040	7463	6620	12	47	45	45	45	—	37	—	—	57
116139	117108	116960	119068	13	1644	1495	1621	1690	843	—	69	912	—
—	—	—	—	14	27241	30657	30376	31295	—	2108	719	—	1389
—	—	—	—	15	—	—	—	—	—	—	—	—	—
180507	182236	181655	187725	16	204	250	1235	250	—	—	985	—	985
35998	42518	43206	43594	17	£38998	£42318	£43206	£43594	£1056	£4116	£1448	£1364	4036
£141509	£139018	£141459	£141131									Less	1364
													Nett Increase 1939/40
													£2672

MEMORANDA.

Reference
to Table.

Head of Service.

- 1 **Salaries Account.—**
Increments per scales and resolutions of the Council.
- 2 **Superannuation Contributions and Allowances.—**
Estimated increase based on salary increments and proportion of allowances to new pensioners chargeable to Rate Fund.
- 3 **Legal Expenses.—**
Increase due to non-recurring item for legal costs recoverable.
- 4 **Town Hall.—**
Decreased provision for re-decoration work, the greater part of which was carried out in 1938/39.
- 5 **St. George's House.—**
No observations.
- 6 **"Fenella," The Burroughs.—**
Decrease due to upkeep costs being charged to Air Raid Precautions Account in respect of occupation by Auxiliary Fire Service.
- 7 **Church Road Properties.—**
Provision for expected rents from tenants of Wingfield Cottages.
- 8 **The Burroughs Property.—**
No observations.
- 9 **Ravensfield House.—**
No observations.
- 10 **Insurances and Stamp Duty.—**
No observations.
- 11 **Printing, Stationery and Postages.—**
No observations.
- 12 **Official Motor Cars.—**
Value of new cars now being written down over a period of **4 years** instead of **5 years**.
- 13 **Other Expenses and Income.—**
Decrease for costs of raising loans based on loans expected to be raised in 1939/40. Certain expenditure items of a non-recurring nature (viz., Ceremonials, etc.) now disappear from the Estimates.
- 14 **Loan Charges.—**
Provision for loan charges in respect of new capital works.
- 15 **Rateable Refunds.—**
The amalgamation of certain districts in Middlesex with the Borough of Twickenham resulted in a refund from the County Council of £985 in 1938/39 in connection with the amount precepted for the West Middlesex Drainage Scheme. This income will not recur in 1939/40.

PROP

E

A

J

A

S

Rent—

Station

Miscel

Loan

King

Minist

Middle

Middle

Middle

isn

Deficien

Rate A

HIGHER EDUCATION ACCOUNT—ESTIMATES, 1939/40.

EXPENDITURE.	General Higher Account.	Choice of Employment and Unemployment Insurance.	Juvenile Organisation Account.	Total.
	£	£	£	£
Proportion of Salaries:—				
Executive Officer	145	72	—	217
Assistants (Juvenile Employment Bureau)	—	1133	—	1133
Juvenile Organisations Officer and Typist	—	—	346	346
Assistants (General)	574	—	—	574
Superannuation and National Insurance	38	66	19	123
	757	1271	365	2393
Rent—Office Accommodation	35	105	35	175
Stationery and Postages	50	175	40	265
Miscellaneous (Car Hire, Equipment, etc.)	—	75	30	105
Loan Charges—Hendon County School	466	—	—	466
King George VI. Scholarships	300	—	—	300
	£1608	£1626	£470	£3704
INCOME.				
Ministry of Labour—(Grant 75%)	—	1220	—	1220
Middlesex County Council—Loan Charges Repayable	466	—	—	466
Middlesex County Council—Higher Account Contribution	250	—	—	250
Middlesex County Council—Grant re Juvenile Organisation	—	—	470	470
	£716	£1220	£470	£2406
Total—Income	£716	£1220	£470	£2406
Deficiencies	£892	£406	—	£1298
Rate Aid Required	£900	£100	—	£1300

sioners

1938/39.

pect of

Certain
from theresulted
pted for

Estimate of Education Committee's Requirements (submitted to on Elementary Account—

Item.	EXPENDITURE.	1. Outlay 1937/38. £	2. Estimate for 1938/39. £	3. Approximate Outlay 1938/39. £	4. Estimate for 1939/40. £
MAINTENANCE OF SCHOOLS.					
1	Teachers' Salaries (including Superannuation)	129298	132403	131296	134550
2	School Furniture	955	1060	1024	1170
	Books, Stationery, Needlework, etc.:—				
3	(a) Existing Schools	6477	7839	6677	7767
4	(b) New Schools	—	988	550	488
5	School Libraries	894	1050	1047	1275
6	Fuel	2051	2487	2464	2640
7	Gas, Electricity and Water	2389	2550	2494	2620
8	Wages of Caretakers, and Allowances	6436	6522	6302	7172
9	Cleaning Materials	745	815	846	880
10	Repairs to Schools, Playgrounds and Fields	8675	8126	8000	8500
11	Renewals Fund (Heating, etc., Plant)	250	250	250	500
12	Rents, Rates and Insurances	5979	6272	6467	6628
13	Conveyance of Children and School Journeys	224	310	593	666
14	Physical Training—Equipment	201	1750	855	1675
15	General Maintenance	781	968	1097	1297
		165355	173390	170052	177828
ADMINISTRATION.					
16	Salaries of Officers (including Superannuation)	8683	9099	9001	9527
17	Printing, Advertising, Postages, etc.	591	600	704	710
18	Rents	864	860	860	860
19	National Insurance	250	250	201	215
20	Legal Expenses and Stamp Duty	228	230	293	300
21	Travelling Expenses—Candidates, etc.	150	140	160	170
22	Miscellaneous Expenses	172	120	150	160
		176293	184689	181421	189770
SPECIAL SERVICES.					
23	Organisation of Physical Training	188	766	919	1003
24	Medical Services	12824	14622	13327	14870
25	Special Schools (Defective Children)	4300	4259	4320	5297
26	Provision of Meals	202	200	261	300
27	Nursery Schools and Classes	—	1665	—	—
		193807	206201	200248	211240
OTHER SERVICES.					
28	Maintenance Allowances	225	250	208	250
29	Children and Young Persons Act (Boarding out)	17	—	—	—
30	Border and Institution Children	2755	2450	2500	2000
31	Approved Schools	512	741	554	663
32	Coronation Celebrations	2217	—	—	—
33	Loan Charges	30146	31500	31196	33000
		229679	241142	234706	247153
34	Estimated Balance at End of Period	7544	2319	10729	6594
		£237223	£243461	£245435	£253747

**Finance & General Purposes Sub-Committee 28th February, 1939),
12 months to 31st March, 1940.**

Item.	INCOME.	5. Income 1937/38. £	6. Estimate for 1938/39. £	7. Approximate Income 1938/39. £	8. Estimate for 1939/40. £
GENERAL.					
35	Hire of Rooms	640	660	930	925
36	Sale of Materials	637	700	700	700
37	Contributions from Non-Provided Schools	49	40	45	45
38	Transfer of Salaries, etc., from other Accounts	2082	2286	2264	2393
39	Contribution from M.C.C. re Physical Training Organisation	19	15	75	75
40	Contributions from Parents	350	400	375	400
41	Border Children	4590	3700	4824	4800
42	Medical Services—Fees, etc.	976	750	775	800
43	Rents—Caretakers' Quarters	411	416	423	460
44	Children and Young Persons Act (Agency)	331	215	230	220
45	Other Items	157	100	250	200
		10242	9282	10891	11018
GRANTS.					
46	Board of Education—Substantive Grant	73490	77000	74500	79500
47	Home Office—Children & Young Persons Act	S	—	—	—
		83740	86282	85391	90518
48	RATE AID	152500	152500	152500	152500
		236240	238782	237891	243018
49	Estimated Balance at Beginning of Period	983	4679	7544	10729
		£237223	£243461	£245435	£253747

ted to
count—
4.
Estimate
for
1939/40.
£
134550
1170
7767
489
1275
2649
2620
7172
860
8500
500
6628
665
1675
1297
177523
9527
710
860
215
300
170
160
159770
1003
14570
5297
300
211249
250
2000
663
33000
247153
6594
2253747

HENDON EDUCATION COMMITTEE.

ESTIMATES FOR THE FINANCIAL YEAR 1st April, 1939, to 31st March, 1940.

EXPENDITURE.

Item.	Particulars.	£	Estimate. £
1	TEACHERS' SALARIES.—		
	It is estimated that there will be an average enrolment of 15000 children, in respect of which 426 Teachers will be required.		
	Salaries of existing Staff (415) based on actual salaries of Teachers in service at 1/2/39, 10 extra Assistants, and the Head Teacher from St. Vincent's Orphanage		128817
	"Supply" Teachers		1250
	Student Teachers—2 at £40		128067
			80
			128147
	Superannuation (Committee's contribution of 5 per cent. of £128,067)		6403
			£134550
2	FURNITURE.—		
	Provision for Repairs		265
	Provision for normal replacements and extras		200
	Radio-grauphones and Cinema Projectors (Committee's contribution)		200
	Tuning pianos		30
	Large dual locker desks (Raising of School Leaving Age)		200
	Miscellaneous items for various schools		275
			£1170
3	BOOKS, STATIONERY, NEEDLEWORK MATERIALS, ETC.—		
	(a) Books and Stationery.—		
	9280 Seniors at average of 4/7d. per head	2127	
	4500 Infants at 3/1d. per head	694	
	720 Seniors at Orange Hill Central School at 7/6d. per head	270	
	250 Children from St. Vincent's Orphanage at 4/7d. per head	57	
	250 Children from Finchley and Private Schools at 4/7d. per head	57	
	<u>15000</u>	<u>3205</u>	
	Add 10% for Increase in Contract Prices	320	3525
	(b) Typewriters.—		
	Allow for 10 new machines	140	
	Maintenance of 87 machines	23	163
	(c) Needlework Materials.—		
	5000 Girls at 2/3d.	562	
	3000 Infants at 1/-	150	
	Allow for initial stocking—Dole Street	50	762
	(d) Manual Instruction Centres (13).—		
	2600. at 7/- per head	910	
	Metalwork equipment in other Centres	100	1010
	Carried forward		5460

EDUCATION COMMITTEE (Contd.).

Item.	Particulars.	£	Estimate. £
	Brought forward		5460
(c)	Domestic Science Centres (11).—		
	11 Centres at £60	660	
	Replacements	40	
			700
(f)	Prizes.—		
	10500 Seniors, 10% = 1050 at 4/6d.	236	
	4500 Infants, 10% = 450 at 2/3d.	51	
			287
(g)	School Registers		50
(h)	Science, Arts and Crafts Materials		875
(i)	School Pictures and Framing		75
(j)	Books for Teachers' Reference Library		100
(k)	Educational Films—Hire Charges		120
(l)	Miscellaneous		100
			<u>£7767</u>
4	BOOKS, ETC., NEW SCHOOLS.—		
	(a) Dole Street Junior and Infant School (450 at 15/-) ..		338
	(b) St. Vincent's Orphanage		150
			<u>£488</u>
5	SCHOOL LIBRARIES.—		
	Books and Binding		920
	Periodicals		15
	Book Cases		23
	Printing, Stationery and Office Equipment		38
	Carriage and Travelling Expenses		15
	Postages		12
	Salaries (Proportion)		252
			<u>£1275</u>
6	FUEL (Based on new contract prices).—		
	897 tons Coke at 37/2d.		1667
	138 tons Coal at 36/6d.		252
	13 tons Anthracite at 60/5d.		39
	94 tons Scotch Washed Singles at 33/-		155
	127 tons Scotch Washed Peas at 32/-		203
	46 tons Eureka Nuts at 36/6d.		84
	Colindale School—Oil Fuel		130
	Firewood		50
	Allow for New Schools		60
			<u>£2640</u>
7	GAS, ELECTRICITY AND WATER.—		
	Gas		867
	Electricity (Lighting only)		940
	Electricity, Heating (Deansbrook)		230
	Water		539
	Allow for New Schools		44
			<u>£2620</u>

EDUCATION COMMITTEE (Contd.).

Item.	Particulars.	Estimate. £
8	CARETAKERS—WAGES AND ALLOWANCES.—	
	Wages	5097
	Lettings Fees	150
	Allowances for Cleaners	1105
	School Windows	200
	Washing of School Towels	160
	Rents of Quarters	460
		<hr/> £7172
9	CLEANING MATERIALS, ELECTRIC LAMPS AND CHIMNEY SWEEPING.—	
	Cleaning Materials	454
	Caretakers' Overalls, Knee Boots, Tools, etc.	50
	Electric Lamps	77
	Chimney Sweeping	22
	"Dusmo" Sweeping Powder and Brooms	260
	Allow for New Schools	17
		<hr/> £880
10	REPAIRS TO SCHOOLS, PLAYGROUNDS, ETC.—	
	(a) General Repairs, including Workmen's Wages	1989
	(b) Special Repairs—Floors, Planing and Relaying	100
	(c) Special Repairs and Improvements submitted by Head Teachers	806
	(d) Playgrounds, treatment of	600
	(e) Upkeep of Playing Fields	850
	(f) Collection and Destruction of School Refuse	190
	(g) Burnt Oak School—Stripping and re-roofing	600
	(h) 3 Netball Pitches at Cressingham Road Field (2) and Burroughs Field (1)	200
	(i) Meads School, extending playground and levelling	180
	(j) Fire Extinguishers, replacement in existing schools	225
	(k) Frith Manor School, levelling of Playing Field	500
	(l) Redecoration of Schools—Midsummer, 1939.—	
	Algernon Road and Caretaker's Cottage—external	175
	Brent Modern and Caretaker's Cottage—external	275
	Colindale and Caretaker's Cottage—external	185
	Goldbeaters and Caretaker's Cottage—internal	370
	Woodcroft and Caretaker's Cottage—external	210
	Meads—external	110
	St. Mary's R.C.—internal	60
	Deansbrook Infants' (old building)—external	180
	St. Paul's C.E.—internal	70
	(m) Surveyor's Department—proportion of salaries	275
	(n) Surveyor's Department—proportion of salaries, now schools	350
		<hr/> £8500
11	LIGHTING AND HEATING PLANTS.—	
	Provision for Renewals Fund, per Hendon U.D.C. Act, 1929	£500

EDUCATION COMMITTEE (Contd.).

Item.	Particulars.	£	Estimate. £
12	RATES, INSURANCES AND RENTS.—		
	(a) Rates		5598
	(b) Insurances.—Boilers, Electric Motors, Fire, W.C.A., Scholars, etc.		730
	(c) Rents.—		
	St. John's Church Hall	30	
	All Saints' Institute	35	
	St. Vincent's R.C. Manual Centre (to 30/6/39)	5	
	St. Paul's Church Hall	20	
	St. Andrew's Hall	220	
			310
			£6628
13	CONVEYANCE OF CHILDREN—FARES AND SCHOOL JOURNEYS.—		
	(a) Hale Area Children		15
	(b) Children travelling to Manual and Domestic Science Centres		80
	(c) Ex-St. Paul's Senior and Dole Street Senior children travelling to St. Mary's C.E. and other Schools		100
	(d) Elstree Children travelling to Edgware School		21
	(e) Children travelling to Swimming Baths		80
	(f) Coach for Dole Street children to Bell Lane (2 months)		100
	(g) Coach for Devonshire Road and Sanders Lane children to Sunnyfields and Bell Lane Schools (2 months)		60
	(h) Guide for (g) above (2 months)		10
	(i) School Journeys		200
			£666
14	PHYSICAL TRAINING—EQUIPMENT, ETC.—		
	Physical Training Equipment		525
	Clothing and Shoes		400
	Lockers		300
	Gymnasium Equipment—Senior Schools		400
	Initial Stocking—New Schools		50
			£1675
15	GENERAL MAINTENANCE.—		
	Telephone Service—Schools		250
	Swimming Instruction		280
	Examination Fees		92
	Grant—Juvenile Organisations Committee		200
	Grant—School Sports Association		100
	Grant—Summer Camp Fund		25
	Play Leadership Schemes		100
	Subscription—British Ship Adoption Society		50
	Miscellaneous		170
			£1297
16	SALARIES OF OFFICERS, ETC.—		
	Per Scale, existing Staff		7928
	Treasurer's Department—proportion		750
	Superannuation (5% Committee's Share).—		
	Officers and Caretakers	603	
	Fund (40 years' annual charges paid by Committee)	246	
			849
			£9527

EDUCATION COMMITTEE (Contd.).

Item.	Particulars.	£	Estimate. £
17	PRINTING POSTAGES, ADVERTISEMENTS, ETC.—		
	Printing and Stationery		420
	Postages		230
	Advertisements		60
			<u>£710</u>
18	RENT OF OFFICES		<u>£860</u>
19	NATIONAL HEALTH AND UNEMPLOYMENT INSURANCES.—		
	Employer's Contributions		<u>£215</u>
20	LEGAL EXPENSES AND STAMP DUTY.—		
	Solicitor's Department—Proportion of Salaries		75
	Stamp Duty, Financial Statement, Cheques, etc.		225
			<u>£300</u>
21	CONDIDATES' TRAVELLING EXPENSES, CAR HIRE, ETC.		<u>£170</u>
22	MISCELLANEOUS—ADMINISTRATION.—		
	Subscriptions, Conference Expenses, Office Furniture, etc.		<u>£160</u>
23	ORGANISATION OF PHYSICAL TRAINING (HENDON'S PROPORTION).—		
	Salaries of Organisers		809
	Superannuation Contributions		40
	Travelling Expenses		88
	Office Accommodation		66
			<u>£1003</u>
24	MEDICAL SERVICES.—		
	Salaries (proportions).—		
	Medical Officer	500	
	Medical Officer (Assistant)	375	
	Medical Officer (Assistant)	331	
	Medical Officer (Assistant)	328	
	Medical Officer (Assistant)	303	
	Medical Officer (Assistant—Resident M.O.)	150	
		<u>1987</u>	
	Nurses	1757	
	Clerks	1299	
	Dentists and Dental Attendants	2715	
	Anæsthetist	350	
	Oculist	350	
	Doctor's Fees (Henrietta Barnet School, etc.)	110	
	Superannuation Contributions	387	
	National Insurance	25	
		<u>8980</u>	
	Carried forward		<u>8980</u>

EDUCATION COMMITTEE (Contd.).

Item.	Particulars.	£	Estimate. £
	Brought forward		8980
	Stationery, Postages, etc.		400
	Drugs and Medical Requisites—Schools, Dental and Eye Clinics		450
	Cleaning and Domestic Sundries		100
	Travelling Expenses and Car Allowances—Proportion of Costs		160
	Rents.—		
	Central Hendon Clinic	350	
	Child's Hill Clinic	220	
	Watling Clinic	550	
	West Hendon Clinic	200	
	Mill Hill Clinic	400	
	Public Health Department (Offices, etc.)	330	
		<hr/>	2050
	Uniforms and Overalls		75
	Equipment and Furnishing of Clinics.—		
	Normal Provision	175	
	Dental Equipment (West Hendon)	200	
	Dental Equipment (Watling Clinic)	200	
		<hr/>	575
	Orthopædic Treatment—Clinics and Hospitals		800
	Optical Treatment (Hospitals)		50
	Tonsils and Adenoids—Treatment at Hospitals		450
	Russell Cotes School of Recovery		450
	Orthoptic Treatment of Squint		200
	North-Western Child Guidance Clinic—Fees		130
			<hr/>
			£14870
25	DEFECTIVE CHILDREN.—		
	5 Blind		425
	3 Myopic		142
	12 Deaf and Dumb		713
	2 Epileptic		130
	8 Physically Defective		614
	33 Mentally Defective		1067
	Short Term Convalescent Cases (exclusive of Russell Cotes)		1000
	Provision for New Long Term Cases		500
	Motor Coach for M.D. Children at Oak Lodge		350
	Guide for M.D. Children at Oak Lodge		78
	Guide for Myopic Child		78
	Provision for Stammerers' Class		200
			<hr/>
			£5297
26	PROVISION OF MEALS.—		
	Milk, cod liver oil, etc., for under-nourished children		£300
28	MAINTENANCE ALLOWANCES.—		
	Provisional sum for Scheme approved by Committee and Board of Education		£250
30	BORDER AND INSTITUTION CHILDREN		<hr/>
			£2000

EDUCATION COMMITTEE (Contd.).

Item.	Particulars.	Estimate. £
31	APPROVED SCHOOLS.—	
	13 Cases at £39 per annum	507
	Allow for 4 additional cases	156
		<u>£663</u>
33	LOAN CHARGES (see pages 82 and 83)	<u>£33000</u>
INCOME.		
35	HIRE OF ROOMS.—	
	Middlesex County Council Evening Classes and Contribution to Expenses	650
	General Lettings	105
	Lettings for Air Raid Precaution Lectures	170
		<u>£925</u>
36	SALE OF MATERIALS.—	
	Cookery, Needlework, etc., including New Centres	<u>£700</u>
37	CONTRIBUTIONS—NON-PROVIDED SCHOOLS.—	
	Proportion—Gas, Water, etc.	<u>£45</u>
38	TRANSFER OF SALARIES AND EXPENSES.—	
	Higher Education Account	757
	Choice of Employment and Administration of Unemploy- ment Insurance	1271
	Juvenile Organisations Account	365
		<u>£2393</u>
39	CONTRIBUTION FROM M.C.C. RE ORGANISATION OF PHYSICAL TRAINING.—	
	Full Year's Income (per Scheme)	<u>£75</u>
40	CONTRIBUTIONS FROM PARENTS.—	
	Based on present and probable new cases	<u>£400</u>
41	BORDER CHILDREN.—	
	The probable income is based on figures extracted by the Chief Attendance Officer	<u>£4800</u>
42	MEDICAL SERVICES.—	
	General (Dental, Tonsils, etc.)	360
	Middlesex County Council Fees	440
		<u>£800</u>

EDUCATION COMMITTEE (Contd.).

Item.	Particulars.	Estimate. £
43	RENTS—CARETAKERS' QUARTERS.—	
	Equivalent Rent Allowances Recoverable	£460
44	CHILDREN AND YOUNG PERSONS ACT, 1933.—	
	Proportion of Officers' Salaries, etc.	208
	Commission re Parental Contributions Collected	12
		£220
45	OTHER ITEMS.—	
	Sundry Small Items of Income, including Refunds of Salaries, National Insurance, Stationery, etc.	£200
46	BOARD OF EDUCATION SUBSTANTIVE GRANT.—	
	Provisional Sum	£79500

Estimate.
£507
156

£563

2000

650

105

170

£925

£700

£45

757

1271

365

£2393

£75

£400

£1800

360

440

£500

EDUCATION COMMITTEE (Contd.).

ELEMENTARY EDUCATION—LOAN CHARGES, 1939/40.

ESTIMATE—ITEM 33.

Original Loan.	Purpose.	Annual Charge.	Rate of		Method of Repay- ment.	Period.		Loan Debt 31/3/1939.	
			Interest.	of		From.	Years.		
£		£	s.	d.				£	
24000	Barnfield School	1237	13	9	P.	P.	1928	50	19050
28300	Barnfield School	1795	5	8	5	1	1930	50	21932
4180	Barnfield and Woodcroft School—Sanitary Accommodation	241	4	5	P.	P.	1938/9	—	2717
3278	Bell Lane School—Extension	182	18	10	3½	2	1909	30	178
1080	Brent Modern School—Site	186	15	0	P.	P.	1933/4	7	180
16500	Brent Modern School	1572	10	0	P.	P.	1935/6	15	12600
3600	Brent Modern School	344	2	2	P.	P.	1935/6	15	2767
1180	Brent Modern School—Heating	115	10	4	P.	P.	1936/7	15	956
700	Brent Modern School—Furniture	88	7	6	P.	P.	1936/7	10	490
5250	Burroughs Playing Field	324	18	8	6	2	1922	59	4963
6800	†Clitterhouse School—Site	485	4	2	P.	P.	1933/4	25	5383
11767	Clitterhouse School	1124	3	4	P.	P.	1933/4	15	7565
720	Clitterhouse School—Heating	69	12	0	P.	P.	1936/7	15	576
394	Clitterhouse School—Furniture	47	10	6	P.	P.	1934/5	10	217
5160	Colindale School—Site	307	9	0	P.	P.	1933/4	27	3612
10280	Colindale School	1131	8	11	P.	P.	1933/4	15	5689
750	Colindale School—Heating	71	13	0	P.	P.	1933/4	15	482
395	Colindale School—Furniture	50	9	5	P.	P.	1933/4	10	176
5000	†Colindale School—Extension	525	10	0	P.	P.	1938/9	15	5000
4300	†Deansbrook School—Site	327	9	4	P.	P.	1934/5	16	2550
7620	†Deansbrook School	848	11	10	P.	P.	1933/4	12	4156
10800	Deansbrook (No. 2) School	990	0	0	P.	P.	1933/4	15	7200
730	Deansbrook (No. 2) School—Heating	70	11	4	P.	P.	1936/7	15	584
250	Deansbrook (No. 2) School—Furniture	30	3	2	P.	P.	1934/5	10	137
20000	†Dole Street School	1250	0	0	P.	P.	1938/9	40	20000
4000	†*Dole Street School—Site (Transfer)	200	0	0	P.	P.	—	—	4000
3000	†Edgware Junior and Infants' School—Site.....	161	11	3	P.	P.	1938/9	60	2975
19330	†Edgware Junior and Infants' School	1192	7	4	P.	P.	1937/8	40	18836
3590	†Frith Manor School—Site	243	19	0	P.	P.	1937/8	30	3332
21386	†Frith Manor School	2261	3	0	P.	P.	1937/8	15	20724
17052	Garden Suburb School	776	18	0	3½	3	1930	30	11998
48200	Goldbeaters School	2460	8	0	P.	P.	1938/9	—	38210
365	Hyde School—Furniture	20	7	4	3½	2	1911	30	39
900	*Hyde School—Land (Transfer)	57	16	8	6½	2	—	—	889
35/1/4	*Hyde Playing Field (Transfer)	2	16	4	5	2	—	—	28
6600	†Orange Hill School	399	9	5	P.	P.	1933/4	35	5550
1800	†Orange Hill School	104	8	5	P.	P.	1933/4	40	1561
45000	†Orange Hill School	2713	8	3	P.	P.	1933/4	36	38307
1180	†Orange Hill School—Furniture	255	18	4	P.	P.	1933/4	7	247
	Carried forward	24269	13	8					275856

† See Memo, page 83.

Original
Loan.

£

2500
4000
1350
8740
475
350
3800
2100
958
4000
6466
7000
1200
600
53700
3495
1672
1500
11965

EDUCATION COMMITTEE (Contd.).

Original Loan.	Purpose.	Annual Charge.		Method of Interest. Repay- ment.		Period.		Loan Debt 31/3/1939.
		£	s. d.			From.	Years.	
	Brought forward	24269	13 8					275856
2500	Page Street School—Site (Transfer)	127	2 0	4½	2	—	—	2432
4000	Sites for Four Schools	51	16 7	3½	1	1900	40	51
1350	Sunnyfield School—Site	233	8 9	P.	P.	1933/4	7	225
8740	Sunnyfields School	790	9 3	P.	P.	1933/4	15	5319
475	Sunnyfields School—Heating	45	18 4	P.	P.	1936/7	15	380
350	Sunnyfields School—Furniture	44	14 5	P.	P.	1933/4	10	156
3800	† Watling Playing Fields	296	17 5	P.	P.	1934/5	16	2312
2100	† Watling Playing Fields—Pavilion	265	4 5	P.	P.	1933/4	7	256
12600	958 Wessex Gardens School—Site	41	5 2	3½	2	1913	60	776
2767	4000 Wessex Gardens School	186	16 8	4	2	1913	50	2969
956	6466 Wessex Gardens School	300	1 2	4	2	1914	50	4769
490	7000 Wessex Gardens School	326	10 0	4	2	1915	49	5137
4963	1200 Wessex Gardens School	72	12 7	P.	P.	1933/4	35	1009
5383	600 Wessex Gardens School—Pathway	54	11 6	6½	2	1921	20	124
7555	53700 Woodcroft School	3647	2 6	5	1	1930	60	37590
576		30754	13 5					339361
217	3495 Edgware School	155	18 9	C.	C.	1895	50	813
3612	1672 Edgware School	54	16 7	C.	C.	1911	30	104
5699	1500 Edgware School	63	1 8	C.	C.	1927	60	1360
482	11965 Edgware School	734	3 0	C.	C.	1931	26	9237
176		31762	13 5					£350875
5000								
2550	Provision for New Loans	1237	6 7					
4156		£33000	0 0					
7200								
584								
137	Principal	17837	15 7					
10000	Interest	15162	4 5					
4000		£33000	0 0					
2075								
8836								
3332								
0724								
1998								
8210								
39								
889								
28								
5550								
1561								
1307								
247								
556								

Memo as to Grants Receivable.

	£
† 50% Grant Items	12768
20% Grant Items	20232
	£33000

Notes.

1. Half Yearly Instalments.
2. Half Yearly Annuity.
3. Yearly Annuity.
- P. Equalised Rate (advance from Loans Pool).
- C. Equalised Rate (advance from Middlesex County Council Consolidated Loans Fund).
- * Transfer with General Account.

HENDON Summary of Rate

Item.	COMMITTEE.	Page herein.	NETT CHARGE TO RATES.		
			1937/38 Actual Charge.	1938/39 Estimates.	
				Approved March, 1938.	Approximate Results.
			1.	2.	3.
			£	£	£
LOCAL EXPENSES:—					
1	Buildings and Town Planning	1	1016	1000	896
2	Public Libraries	3	14345	15435	14936
3	Works and Fire Brigade	14	52384	55225	58723
4	Estates, Parks and Allotments	39	21969	22830	20997
5	Public Health and Medical Services	48	26565	26045	28102
6	Highways	60	76741	82396	80147
7	Air Raid Precautions (Fire Protection)	62	—	2000	838
			193020	204931	204639
8	Finance and General Purposes	69	141509	139918	141459
			334529	344849	346098
9	Higher Education	71	1100	1200	1200
10	Elementary Education	73	152500	152500	152500
11	Housing Rate Contributions	—	10850	9224	10986
12	Coronation Celebrations	—	2563	—	—
13			501542	507773	510784
EXPENSES UNDER PRECEPTS:—					
14	Middlesex County Council	87	452826	498072	499505
15	Metropolitan Police	87	85746	91856	91830
16	Assessment Committee	87	1179	1330	1330
17			1041293	1099031	1103449
18	Less General Exchequer Grant	—	115597	113240	113240
			£925696	£985791	£990209

COMPARISON OF NETT REQUIREMENTS AND INCREASES.								
Year.	NETT REQUIREMENTS.				INCREASE ON PRECEDING YEAR.			
	Local Expenses.	Education Account.	Other Authorities.	Total.	Local Expenses.	Education Account.	Other Authorities.	Total.
1937/38	£347942	£153600	£539751	£1041293	£31504	£10200	£14665	£56369
1938/39	£354073	£153700	£591258	£1099031	£6131	£100	£51507	£57738
1939/40	£369932	£153800	£634775	£1158507	£15859	£100	£43517	£59476
			Cumulative Increase		£53494	£10400	£109689	£173583

PROPOSALS.				
	Amount Required. £	Provision from Balances and Exchequer Grant. £	Amount to be Raised. £	Proposed Rate in the £ pence.
Purposes of Hendon Corporation:—				
Item 13, Column 6	523732	17563	506169	64.89
Purposes of Middlesex County Council (Precept)	539760	—	539760	69.20
Purposes of Metropolitan Police (Precept)	94010	478	93532	11.99
Purposes of Central Middlesex Assessment Committee (Precept)	1005	18 (Cr.)	1023	13
	1158507	18023	1140484	146.21
General Exchequer Grant	—	110884	110884	14.21
	£1158507	£128907	£1029600	132.00

CORPORATION
Estimate

Item.

1

2

3

4

5

6

7

8

9

10

11

12

13

14

15

16

17

18

CORPORATION.
Estimates, 1939/40.

Item.	COMMITTEE.	1939/40 ESTIMATES.			NETT RATE CHARGE, 1939/40.	
		Outlay.	Income.	Nett Charge to Rates.	Decreases on 1938/39 Estimates.	Increases on 1938/39 Estimates.
		4.	5.	6.	7.	8.
		£	£	£	£	£
LOCAL EXPENSES:—						
1	Buildings and Town Planning	1022	52	970	—	—
2	Public Libraries	17547	1565	15982	30	—
3	Works and Fire Brigade	73041	13799	59242	—	547
4	Estates, Parks and Allotments	31174	9093	22081	—	4017
5	Public Health and Medical Services	41537	13260	28277	749	—
6	Highways	127175	38854	88321	—	2232
7	Air Raid Precautions (Fire Protection)	4850	2910	1940	60	5925
		296346	79533	216813	—	—
8	Finance and General Purposes	187725	43594	144131	839	12721
		484071	123127	360944	—	4213
9	Higher Education	1300	—	1300	839	16934
10	Elementary Education	152500	—	152500	—	100
11	Housing Rate Contributions	8988	—	8988	—	—
12	Coronation Celebrations	—	—	—	236	—
13		646859	123127	523732	—	—
EXPENSES UNDER PRECEPTS:—						
14	Middlesex County Council	539760	—	539760	—	41688
15	Metropolitan Police	94010	—	94010	—	2154
16	Assessment Committee	1005	—	1005	325	—
17		1281634	123127	1158507	1400	60876
18	Less General Exchequer Grant.....	—	110884	110884	—	2356
		£1281634	£234011	£1047623	£1400	63232
					Less	1400
						£61832

**A Statement shewing how the amounts re-
quired are to be provided is given on page 87.**

**The Statement includes all Rate Fund
Accounts.**

AR.
Total.
£56269
£57738
£59476
£173588
Proposed
Rate in
the £
pence.
64.80
69.20
11.90
13
16.21
14.21
12.00

Precepts from Other Authorities

Actual Outlay 1937/38.		Expenditure.	Approved Estimate 1938/39.		Approximate Outlay 1938/39.	Precepts for 1939/40.	
per £. pence.	Amount. £		per £. pence.	Amount. £	Amount. £	per £. pence.	Amount. £
MIDDLESEX COUNTY COUNCIL.—							
30.694	231073	Public Health (including Public Assistance)	33.039	252583	253310	34.108	266043
8.376	63057	Highways and Bridges	8.602	65762	65952	8.251	64558
2.197	16540	Care of the Mentally Defective	2.252	17217	17266	2.355	18369
1.709	12866	Mental Hospitals	1.689	12912	12949	1.638	12776
.909	6843	Administration of Justice935	7148	7169	.981	7652
.826	6219	Blind Persons Act786	6009	6026	.968	7550
.666	5014	County Buildings832	6361	6379	.643	5015
.615	4630	Open Spaces743	5680	5696	.997	7777
.436	3282	Rivers Pollution Prevention489	3738	3749	.567	4423
.125	941	County Valuation271	2072	2078	.141	1100
.161	1212	Public Control133	1017	1020	.151	1177
—	—	Air Raid Precautions198	1514	1518	.916	7145
2.732	20567	Other Services and Expenses	3.394	25947	26022	4.257	33205
1.000	7528	Contribution towards General Exchequer Grant974	7446	7468	.939	7324
8.475	63802	Higher Education	8.765	67009	67201	8.500	66300
.173	1303	Registration of Electors167	1277	1280	.200	1560
6.037	45448	West Middlesex Drainage	6.068	46390	46523	6.000	46800
65.131	490325		69.337	530082	531606	71.612	558574
4.981	37499	Less Proceeds of Local Taxation Licences and Appropriation from Balances	4.187	32010	32101	2.412	18814
60.150	452826	Total—Middlesex County Council	65.150	498072	499505	69.200	539760
11.000	85746	METROPOLITAN POLICE	11.500	91856	91830	11.500	94010
	1179	CENTRAL MIDDLESEX ASSESSMENT COMMITTEE		1330	1330		1005
	£539751			£591258	£592665		£634775

MEMORANDUM AS TO PRECEPTS.

Year Ended.	Middlesex County Council.	Metropolitan Police.	Assessment Committee.	Totals.
31st March, 1930	£126986	£53944	£1326	£226900
31st March, 1931	£269975	£57630	£1180	£328785
31st March, 1932	£281454	£63621	£683	£345758
31st March, 1933	£287856	£65300	£1089	£354245
31st March, 1934	£324798	£65959	£642	£391399
31st March, 1935	£317746	£71680	£1320	£390746
31st March, 1936	£369536	£78947	£1405	£440888
31st March, 1937	£441011	£82488	£1587	£525086
31st March, 1938	£452826	£85746	£1179	£539751
31st March, 1939	£498072	£91856	£1330	£591258
31st March, 1940	£539760	£94010	£1005	£634775

Receipts for 1933/34. Amount £

256093
64576
19329
12776
7052
7000
7005
7777
4422
1100
1177
7145
33205

7224
66200
1560
46800
558574

15814
530750
94010
1005
2624775

Receipts for 1933/34. Amount £

256093
64576
19329
12776
7052
7000
7005
7777
4422
1100
1177
7145
33205

7224
66200
1560
46800
558574

15814
530750
94010
1005
2624775

Rate Estimates, 1939/40.

STATEMENT OF GROSS REQUIREMENTS AND PROVISION - RATE FUNDS.

PURPOSES OF HENDON CORPORATION.—	Gross Requirements.		Provision.			
	£	£	Government Grants.	Middlesex County Council.	Other Income.	Total.
General Fund Accounts.—						
Page 85—Col. 4—Item 13		646859	27125	49486	46516	123127
Less Education (Page 85—Item 9/10)						
Net	153800		1220	1186		2406
Housing (Page 85—Item 11) Net	8988	162788	79500		11018	90518
Education Account.—						
Higher Education (page 71)	3704					
Elementary Education (page 72)	247153	484071				
Housing Account (page 64)						
Small Dwellings Acts Account			3468		54440	57908
Private Street Improvements Account (page 107)					1576	1976
GENERAL EXCHEQUER GRANT.—						
Page 85—Item 18		250857				2960
FREE BALANCES.—						
General Revenue Account (page 106)		66896				
Less Provision under Section 12 of the Rating and Valuation Act, 1925	807277	2092				
Rate Appropriation Account (page 106)		3361				
TRANSFER ADJUSTMENTS.—						
Education Account						75582
Small Dwellings Acts Account						58019
Private Street Improvements Account						17563
Rate Appropriation Account (page 106)						460
AMOUNT TO BE RAISED.—						
Rate Required: 11/- in the £ (132d. x £7,800 per penny)						18023
Net						4650
PURPOSES OF MIDDLESEX COUNTY COUNCIL (Precept) (page 86)						
PURPOSES OF METROPOLITAN POLICE (Precept) (page 86)						
PURPOSES OF CENTRAL MIDDLESEX ASSESSMENT COMMITTEE (Precept) (page 86)						
Net						1029600
Net						£1442052

Approved by Council—27th March, 1939.

GENERAL RATE ESTIMATES

1939-1940.

APPENDIX.

Contents of Appendix.

	Pages.
LOANS POOL REVENUE ACCOUNT	89
LOANS POOL ADVANCES	89
SUMMARY OF LOAN CHARGES	90—91
LOAN CHARGES FALLING OUT—1939/40 TO 1953/54	92
GENERAL EXCHEQUER GRANT	93
HOUSING REVENUE ACCOUNT	94
HOUSING SCHEMES LOAN CHARGES	95
CAPITAL ITEMS INCLUDED IN THE ESTIMATES	96—97
CAPITAL WORKS (PROVISIONAL) ESTIMATES	98—99
PUBLIC HEALTH AND JOINT MEDICAL SERVICES	100—102
SALARIES AND GENERAL ESTABLISHMENT CHARGES—APPORTIONMENT	103
COMPARISON OF ESTIMATES WITH APPROXIMATE RESULTS—1938/39	104
RATES COLLECTED AND EXCHEQUER GRANT PER HEAD OF POPULATION.....	105
RATE INCOME ACCOUNT AND RATE APPROPRIATION ACCOUNT—1938/39	106
GENERAL RATE FUND REVENUE ACCOUNT—1938/39	106
SMALL DWELLINGS ACQUISITION ACTS REVENUE ACCOUNT—1939/40	107
PRIVATE STREET IMPROVEMENTS REVENUE ACCOUNT—1939/40	107
GENERAL INSURANCE FUND—1939/40	107
SUMMARY OF RETURNS OF HOUSES BROUGHT INTO RATING	108
ESTIMATE OF RATEABLE VALUES AND RATE PRODUCT	109
DETAILS OF RATES LEVIED	110
DETAILED COMPARISON OF ESTIMATES.....	111
SUMMARY OF RATEABLE VALUES AND DISTRIBUTION OF RATE BURDEN	112
ANALYSIS AND TOTAL OF RATEABLE VALUES AS AT 31st MARCH, 1939	113—114

Repaym
PrinReinvest
Repay
able AReinvest
writte
AccouInterest
age ra
£3 12

Estimate

(a) The
of I
exte(b) The
as fSewers
County
Local R
Parks a
Public
Public
Fire St
Disposa
Hospita
Matern
Public
Baths a
Public
Allotme
PublicPrivate
S.D.A.
Housin
Housin

Elemen

LOANS POOL REVENUE ACCOUNT—1939-1940.

Expenditure.				Income.			
		£	s. d.			£	s. d.
Repayments to Lenders.—				Balance in hand, 1st April, 1939			
Principal			45795 13 6	(estimated)		109568 19 0	
Reinvestment of Instalment				Advances Repaid—Instalments.—			
Repayments on Recoverable Accounts	18185 19 5			From Revenue Accounts.—			
Reinvestment of amounts				General Rate Fund A/c	49764 18 7		
written off Education				Housing Account	3668 3 8		
Accounts	13553 9 10			Education Account	13553 9 10		
			31739 9 3	Advances Repaid—Instalments.—			
Interest estimated to be payable at average rate of interest of approximately £3 12s. 6d. per cent.				From Recoverable Accounts.—			
			34301 1 5	Private Street Improvements	15535 8 8		
			131836 4 2	Small Dwellings Acts	2650 10 9		
Estimated Balance at 31st March, 1940			117226 8 6			66986 12 1	
			£249062 12 8	Interest Charged to Borrowing Accounts			54301 1 5
							£249062 12 8

NOTES.

(a) The estimated balances at 1st April, 1939, and 31st March, 1940, represent the sum available for Redemption of Debt. Statutory powers exist to invest the sum in Corporation Funds against Loan Sanctions or in external investments, and £77,938 1s. 5d. was so invested as at 31st March, 1939.

(b) The Contributions from the Borrowing Accounts (Income above) are included in the Estimates for Loan Charges as follows:—

	Principal.		Interest.	
	£	s. d.	£	s. d.
General Rate Fund (included page 65)	49764	18 7	33561	18 1
Education Account (included page 72)	13553	9 10	9875	14 1
	63318	8 5	43437	12 2
Housing Accounts (page 95)	3668	3 8	7203	18 2
Private Street Improvement (page 107)	15535	8 8	2361	1 10
S.D.A. Acts—Advances (page 107)	2650	10 9	1298	9 3
(See Summary—Page 91)	£85172	11 6	£54301	1 5

LOANS POOL ADVANCES.

(including Transfers and Re-borrowings.)

Purposes.	Year	Year	Year	Year	Year	Year
	1933/34.	1934/35.	1935/36.	1936/37.	1937/38.	1938/39.
		£	£	£	£	£
Sewers and Sewage Disposal	182770	22240	2990	4500	43124	22410
County Roads	45157	8965	5000	—	5000	24205
Local Roads	69570	11722	6100	8612	4000	12582
Parks and Pleasure Grounds	83512	86800	86275	100798	11601	42340
Public Offices and Buildings	38510	1500	4850	—	5575	2650
Public Depôts	12650	—	—	—	—	8000
Fire Stations and Appliances	13210	1000	—	—	4000	6500
Disposal of House Refuse	13130	1800	—	—	—	—
Hospital	74697	—	—	317	4625	—
Maternity and Child Welfare	10315	975	—	—	—	2900
Public Conveniences	2500	250	—	—	—	450
Baths and Washhouses	—	15000	1900	12750	5000	—
Public Libraries	27770	—	8000	10318	3273	—
Allotments	5900	4700	—	—	—	2500
Public Lighting	—	—	—	—	—	—
	579691	154952	115115	137295	86198	124537
Private Street Improvements	45100	16852	6000	12000	12000	16800
S.D.A. Acts Advances	—	25000	10000	6500	3500	5000
Housing (Council) Schemes	45400	19450	9500	22947	62886	52152
Housing—Subsidies to Owners	—	300	—	—	—	—
	670191	216554	140615	178742	164584	198489
Elementary Education	128432	10274	18500	7507	25000	85946
	£798623	£226828	£159115	£186249	£189584	£284435

SUMMARY OF LOAN CHARGE ESTIMATES, 1939/40.

Purpose.	Earmarked Loans.		Pool Advances.		Total Estimated Charges		Loan Debt at		Approximate Outlay					
	Principal.	Interest.	Principal.	Interest.	1939/40.		31st March, 1939.		1938/39.					
					£	s. d.	£	s. d.	£	s. d.	£	s. d.		
Sewers and Sewage Disposal	6853	7 11	5785	3 0	10422	15 0	5718	15 6	28880	1 5	280368	12 3	30237	17 1
do.	—	—	—	—	210	13 4	180	18 1	391	11 5	—	—	—	—
do. —New Loans	—	—	—	—	4476	19 8	2148	4 0	11134	13 6	84647	2 0	10276	2 6
Main and County Road Improvement	3281	9 6	1228	0 4	100	0 0	365	0 9	465	0 9	—	—	—	—
do.	—	—	—	—	—	—	—	—	—	—	—	—	—	—
do. —New Loans	—	—	—	—	3070	15 10	1225	15 0	13873	18 8	84210	7 2	14342	9 9
Local Road Improvements	—	—	—	—	61	6 8	695	1 11	756	8 7	—	—	—	—
do.	—	—	—	—	340	0 0	90	12 6	430	12 6	2500	0 0	—	—
do. —New Loans	—	—	—	—	—	—	45	6 3	45	6 3	—	—	—	—
Public Lighting	—	—	—	—	12398	11 9	12524	7 10	31859	13 8	449888	2 0	31740	8 6
do.	1572	10 11	5364	3 2	8	10 0	513	4 4	521	14 4	—	—	—	—
do. —New Loans	—	—	—	—	945	19 10	1059	11 5	2846	15 2	6313	9 9	6173	8 9
Parks and Pleasure Grounds	—	—	—	—	—	—	—	—	—	—	—	—	—	—
do.	—	—	—	—	—	—	—	—	—	—	—	—	—	—
do. —New Loans	—	—	—	—	—	—	—	—	—	—	—	—	—	—
Public Offices and Buildings	—	—	—	—	—	—	—	—	—	—	—	—	—	—
do.	—	—	—	—	—	—	—	—	—	—	—	—	—	—
do. —New Loans	—	—	—	—	—	—	—	—	—	—	—	—	—	—
Public Depôts, etc.	—	—	—	—	—	—	—	—	—	—	—	—	—	—
do.	—	—	—	—	1152	0 0	602	7 9	1754	7 9	16617	10 0	1271	14 9
do. —New Loans	—	—	—	—	—	—	—	—	—	—	—	—	—	—
Fire Stations and Appliances	—	—	—	—	—	—	—	—	—	—	—	—	—	—
do.	284	8 4	336	0 2	1587	5 2	678	12 2	2886	5 10	22959	17 8	3459	7 11
do. —New Loans	—	—	—	—	—	—	—	—	—	—	—	—	—	—
House Refuse Removal	1570	7 10	685	19 2	925	2 4	325	17 3	3507	6 7	23753	2 8	3581	10 8
Hospitals	—	—	—	—	3002	17 0	2075	12 6	5078	9 6	57258	11 6	5187	6 5
do.	—	—	—	—	—	—	—	—	—	—	—	—	—	—
do. —New Loans	—	—	—	—	—	—	—	—	—	—	—	—	—	—
Maternity and Child Welfare	200	0 0	207	10 0	669	7 2	464	14 0	1541	11 2	17018	19 1	1575	16 2
Mortuary	39	11 7	5	1 5	—	—	—	—	44	13 0	145	0 9	44	13 0
Public Conveniences	271	18 10	180	10 2	261	17 6	164	9 2	878	15 8	8356	10 6	775	6 5
do.	—	—	—	—	—	—	—	—	—	—	—	—	—	—
do. —New Loans	—	—	—	—	—	—	—	—	—	—	—	—	—	—
Baths and Washhouses	683	7 11	528	17 1	1543	13 4	1116	15 9	3872	14 1	40917	7 4	3882	12 4
Public Libraries	—	—	—	—	2036	2 2	1458	7 1	3484	9 3	40230	16 5	3548	11 6
Allotments	19	19 4	241	1 8	268	18 4	322	16 10	852	16 2	13502	4 10	862	11 3
S.T. { Existing Loans	18803	17 10	16847	12 7	40384	8 7	31267	19 6	116383	18 6	1205741	18 8	116959	17 0
do. { New Loans	—	—	—	—	380	10 0	2293	18 7	2674	8 7	—	—	—	—
Carried forward	18803	17 10	16847	12 7	49764	18 7	33561	18 1	119068	7 1	1205741	18 8	116959	17 0

CARRIAGE FORWARDED 18803 17 10 10847 12 7 49764 18 7 33561 18 1 110068 7 1 1205741 18 8 116659 17 0

Summary of Loan Charge Estimates, 1939/40—Continued.

Purpose.	Earmarked Loans.		Pool Advances.		Total Estimated Charges		Loan Debt at 31st March, 1939.		Approximate Outlay 1938/39.	
	Principal £ s. d.	Interest £ s. d.	Principal £ s. d.	Interest £ s. d.	1939/40. £ s. d.	£ s. d.	£ s. d.	£ s. d.	£ s. d.	£ s. d.
Brought forward	18893 17 10	10847 12 7	49764 18 7	33561 18 1	119068 7 1	1205741 18 8	116959 17 0			
Private Street Improvements	—	—	15535 8 8	2361 1 10	17896 10 6	53133 4 10	14931 2 2			
Small Dwellings Acts Advances	2811 15 2	531 10 11	2650 10 9	1298 9 3	7292 6 1	47151 13 0	7970 19 7			
Housing (Council) Schemes	2798 5 4	13752 19 7	3650 13 4	6904 6 0	27106 4 3	476243 17 10	27203 16 0			
do. —New Loans	—	—	—	294 10 7	294 10 7	—	—			
Housing (Assisted) Schemes	2247 2 10	12005 12 3	—	—	14252 15 1	190546 2 4	14081 3 4			
Housing—Subsidies to Owners	—	—	17 10 4	5 1 7	22 11 11	140 2 8	23 4 8			
S.T. { Existing Loans	26751 1 2	43137 15 4	71238 11 8	41836 18 2	182964 6 4	1981956 19 4	181170 2 9			
do. { New Loans	—	—	380 10 0	2588 9 2	2968 19 2	—	—			
Elementary Education	4284 5 9	5286 10 4	13273 6 6	8918 10 10	31762 13 5	350875 1 11	31195 10 0			
do. —New Loans	—	—	280 3 4	657 3 3	1237 6 7	—	—			
Higher Education	161 19 7	303 12 11	—	—	465 12 6	7689 1 0	465 12 6			
S.T. { Existing Loans	31197 6 6	48727 18 7	84511 18 2	50755 9 0	215192 12 3	2840521 2 3	212831 5 3			
do. { New Loans	—	—	660 13 4	3545 12 5	4206 5 9	—	—			
Grand Total	£31197 6 6	£48727 18 7	£85172 11 6	£51301 1 5	£219398 18 0	£2340521 2 3	£212831 5 3			

Loan Charges on existing Loans falling out—1939/40 to 1953/54.

Year ending 31st March.	Rate Fund.			Education.			Total.			Non-Rate Accounts.			Total all Accounts. £ s. d.	Year ending 31st March.
	Earmarked Loans, Principal and Interest.	Pool Advances, Principal only.	Earmarked Loans, Principal and Interest.	Pool Advances, Principal only.	Rate Accounts.	Earmarked Loans, Principal and Interest.	Pool Advances, Principal only.	Rate Accounts.	Earmarked Loans, Principal and Interest.	Pool Advances, Principal only.	Total			
											£	s.		
1940	565 7 11	347 13 4	234 15 5	1228 19 4	2376 16 0	121 9 8 (a)	—	—	—	—	—	2498 5 8	1940	
1941	811 10 7	2225 5 0	75 7 4	—	3112 2 11	527 2 6 (a)	—	—	—	5628 18 8 (c)	—	9268 4 1	1941	
1942	1355 2 1	869 3 6	27 5 9	—	2251 11 4	577 14 7 (d)	—	—	—	—	—	2829 5 11	1942	
1943	271 3 2	715 19 2	—	82 15 6	1069 17 10	266 15 9 (d)	—	—	—	428 11 6 (c)	—	1765 5 1	1943	
1944	997 8 8	2843 8 6	—	—	3840 17 2	949 15 2 (d)	—	—	—	7 2 11 (e) 1714 0 0 (c)	—	6511 15 3	1944	
1945	1545 12 2	294 17 6	—	724 18 6	2565 8 2	148 2 7 (d) 11 18 10 (b)	—	—	—	1714 0 0 (c)	—	4439 9 7	1945	
1946	555 7 7	1907 3 5	152 0 0	70 0 0	2684 11 0	78 14 0 (b)	—	—	—	2400 0 0 (c)	—	5163 5 0	1946	
1947	561 15 7	818 3 7	—	—	1379 19 2	86 3 4 (b)	—	—	—	17 10 4 (b)	—	1483 12 10	1947	
1948	1342 4 8	988 3 10	—	2081 9 11	4411 18 5	—	—	—	—	46 10 4 (b)	—	4458 8 9	1948	
1949	297 10 0	626 3 11	—	720 0 0	1553 13 11	—	—	—	—	243 13 4 (b)	—	1797 7 3	1949	
1950	53 5 5	886 8 8	—	542 0 2	1481 14 3	443 6 2 (a) 171 8 4 (b)	—	—	—	—	—	2096 8 9	1950	
1951	312 7 4	1194 14 4	—	831 13 4	2338 15 0	218 8 4 (b)	—	—	—	1013 5 5 (d) 49 4 9 (b)	—	3619 13 6	1951	
1952	2943 11 9	1636 16 1	—	—	3680 7 10	—	—	—	—	156 5 0 (d)	—	3836 12 10	1952	
1953	119 0 5	112 0 0	—	1480 0 0	1711 0 5	—	—	—	—	393 17 0 (d)	—	2104 17 5	1953	
1954	174 14 5	1895 9 2	—	333 0 0	2403 3 7	—	—	—	—	218 15 0 (d) 98 0 0 (b)	—	2719 18 7	1954	

Note re Loans Pool Advances. Interest at the average rate for the year also falls out of charge.
Reference to Non-Rate Accounts:—

- (a)—Assisted Housing Schemes.
- (b)—Council Housing Schemes.
- (c)—Private Street Improvements.
- (d)—Small Dwellings Acts Advances.
- (e)—Allotments.

STATEMENT
 any) as
 fixed gr
 1. CAPITAL
 provision
 Appropri
 On 14
 the 31st
 2. DEFECT
 of the 1
 losses o
 the ope
 part of
 3. EXCESS
 4. Add—the
 partly b
 the "lo
 III. V.
 Edg
 Ren
 5. Add—the
 Section
 Section
 Health
 6. TOTAL o
 (includi
 First Fixed
 193
 193
 193
 Second Fixed
 193
 193
 193
 193
 193
 Third Fixed
 193
 193
 193

GENERAL EXCHEQUER GRANT.

BOROUGH OF HENDON.

STATEMENT showing the amount of the General Exchequer Grant (including the Supplementary Exchequer Grant, if any) as provisionally calculated to be payable to the Council in respect of the third year (1939/40), of the third fixed grant period under the Local Government Acts, 1929 and 1937.

Items.	£	£
1. CAPITATION SUM, being the sum, calculated on the basis of estimated population, at the provisionally calculated figure of 149d. per head, which is set aside out of the County Apportionment under Section 91 (1) of the 1929 Act:— On 140,650, being the estimated population in 1936 of the Borough as constituted on the 31st March, 1939		87320
2. DEDUCT—the contribution (if any) which falls under Section 94 (1) (c) (ii) of the 1929 Act to be made out of the above sum towards making good a proportion of the losses of "losing" separately rated areas in the Administrative County resulting from the operation of Parts I., III., V. and VI. (apart from Section 94) of that Act <i>re</i> added part of Finchley		2
3. EXCESS of Item 1 over Item 2		87318
4. ADD—the contribution which falls under Section 94 (1) (b) of the 1929 Act to be made, partly out of moneys provided by Parliament as a Supplementary Exchequer Grant and partly by the gaining areas in the Administrative County, to make good a proportion of the "losses" (if any) to the Borough or District resulting from the operation of Part I., III., V. and VI. (apart from Section 94) of that Act:—		
Edgware	1638	
Remainder of Borough	33711	
	£35349	
Ten-fifteenths thereof =		23566
		110884
5. ADD—the amount of the increase (if any) under a Scheme made by the Minister under Section 93 of the 1929 Act, in the sum set aside out of the County Apportionment under Section 91 (1) by reason of the Council being a Welfare Authority under the Public Health Act, 1936		2760
6. TOTAL of amounts shown against Items 3, 4 and 5, being the General Exchequer Grant (including the Supplementary Exchequer Grant, if any) payable to the Council		£113644
	£	
Estimates, page 47	2760	
Estimates, page 85	110884	
	£113644	

MEMORANDUM AS TO GENERAL EXCHEQUER GRANTS IN PREVIOUS YEARS.

	Capitation Sum. £	Supplementary Exchequer Grant. £	Maternity and Child Welfare Grant. £	Total £
First Fixed Grant Period.—				
1930/31	50137	33788	2300	86225
1931/32	52231	35426	2300	89957
1932/33	52231	35426	2300	89957
Second Fixed Grant Period.—				
1933/34	74133	35426	2300	112159
1934/35	74400	35349	2300	112049
1935/36	74400	32992	2300	109692
1936/37	74400	30636	2300	107336
Third Fixed Grant Period (Provisional).—				
1937/38	87318	28279	2760	118357
1938/39	87318	25922	2760	116000

HOUSING REVENUE ACCOUNT.

Year Ending 31st March, 1940.

Expenditure.	£	s.	d.	Income.	£	s.	d.
Loan Charges.—				Rent Income from Houses.—			
Per details, page 95	41850	10	9	Child's Hill No. 1	1161	6	8
Contribution to Repairs Fund	7962	17	10	Child's Hill No. 3	1534	17	4
General Rate Fund.—				Child's Hill (1919 Act)	1231	15	0
Supervision and Management—5% on Rents Collectable	1990	14	5	Brent Hill (1919 Act)	6261	0	4
Insurances	412	8	10	Brent Hill (90 Houses)	2728	14	0
Lighting Passages and Staircases (Flats)	45	0	0	Bittacy Hill (Flats)	1303	9	4
				Kingsbury Road (1923 Act)	1566	1	4
				The Hyde	4883	13	4
				Goldsmith Avenue and Clitterhouse Lane (Flats) (1924 Act)	936	0	0
				Clitterhouse Lane	9456	4	0
				Reets Farm (1924 Act, 1930 Act and General Powers)	3330	7	8
				Dole Street	5421	0	0
				<u>39814</u>	<u>9</u>	<u>0</u>	
				Government Subsidies.—			
				£	s.	d.	
				1919 Act	662	4	5
				1923 Act	1280	0	0
				1924 Act	682	10	0
				1930 Act	843	15	0
				<u>3468</u>	<u>9</u>	<u>5</u>	
				Rate Contribution.—			
				1919 Act	7800	0	0
				1930 Act	307	10	0
				<u>8107</u>	<u>10</u>	<u>0</u>	
				<u>51390</u>	<u>8</u>	<u>5</u>	
				Balance—Deficit	880	3	5
				<u>£52270</u>	<u>11</u>	<u>10</u>	
				<u>£52270</u>	<u>11</u>	<u>10</u>	

RATES AND WATER CHARGES ACCOUNT.

Amount payable for Local Rates and Water Charges	£	s.	d.	Amount chargeable to Tenants	£	s.	d.
	14101	0	0		11625	0	0
General Rate Fund.—							
For Supervision and Management	524	0	0				
<u>£14625</u>	<u>0</u>	<u>0</u>		<u>£11625</u>	<u>0</u>	<u>0</u>	

HOUSING SCHEMES.

Estimated Loan Charges, 1939/40.

Scheme.	No. of Houses.	Sites.	Houses.		Roads and Sewers.		Total.							
			£	s. d.	£	s. d.	£	s. d.						
Bittacy Hill	52	58	6	6	945	1	0	18	15	4	1022	2	10	
Brent Hill (Assisted)	178	286	11	6	10742	0	7	1273	2	8	12301	14	9	
Brent Hill No. 2	90	197	14	2	2023	1	8	341	14	9	2562	10	7	
Child's Hill No. 1	50	28	1	5	418	18	0	—	—	—	446	19	5	
Child's Hill (Assisted)	37	45	13	4	1922	8	2	281	3	0	2249	4	6	
Child's Hill No. 3	52	96	3	8	1185	17	4	227	0	4	1509	1	4	
Clitterhouse Lane	300	493	8	10	6294	11	9	1109	8	5	7897	9	0	
Clitterhouse Lane and Goldsmith Avenue Flats	45	32	15	8	806	10	2	91	18	9	931	4	7	
The Hyde	156	261	5	6	3323	15	7	544	3	8	4129	4	9	
Kingsbury Road	52	96	19	2	1289	2	8	70	1	2	1456	3	0	
Reets Farm	138	153	13	0	2366	15	10	438	14	10	2959	3	8	
		1150	1750	12	9	31318	2	9	4396	2	11	37464	18	5
Dole Street	140	857	12	2	2919	2	6	617	17	8	4394	12	4	
Total Charges after Land, etc., Transfers	1290	£2608	4	11	£34237	5	3	£5014	0	7	£41859	10	9	
Estimated 1938/39	—	£2626	11	4	£33865	15	6	£4905	19	5	£41398	6	3	

**Proposed Outlay on Permanent and Semi-Permanent Works
(other than Repairs and Replacements) included in Revenue
Estimates, 1939/40.**

Items not Covered by Loan Sanctions.

Estimate Item.		£	£	Estimate Item.
	BUILDINGS.—			
454	Shelter—Watling Park	150		
455	Bandstand—Watling Park	400		
641	Sholter—Clitterhouse Playing Fields	150		
1088	Messroom, etc.—Isolation Hospital	100		
			800	
	ROADWAYS AND SEWERS.—			
1206/1224	Improvement Works on County Roads	4109		
1256	Surface Water Drain—Wilmington Fold	100		
			4209	
	MECHANICAL AND OTHER VEHICLES.—			
91	Cesspool Emptying Machine	450		
792	Parks Tractors	600		
			1050	
	FENCING.—			
381	Fencing—Sunny Hill Park	45		
417	Fencing—Princes Park	16		
450	Fencing—Watling Park	32		
468	Fencing—Colindale Park	10		
513	Fencing—Woodcroft Park	50		
608/9	Fencing—Brent Park	80		
625	Fencing—Elm Park	20		
647	Fencing—Clitterhouse Playing Fields	25		
785/6	Fencing—Riverside Walks	175		
1260	Fencing—Abercorn Road	121		
			574	
	PARKS AND OPEN SPACES—LAY-OUTS, ETC.—			
400	New Footpaths—Mill Hill Park	100		
701	Pavilion Lighting—Montrose Playing Fields	45		
713a	Water Supply and Latrines—Mote Mount Open Space	500		
788	Footbridges—Riverside Walks	375		
791	Clearing and Levelling—Riverside Walks	200		
			1220	
	STREET LIGHTING, FIRE HYDRANTS AND ALARMS.—			
	Street Lighting Extensions—New Streets and Roads.—			
1306	Lamp Columns	140		
1307	Lanterns and Fittings	450		
1310	Lamp Columns—Vivian Avenue	420		
202	Fixing New Fire Hydrants	750		
205	New Fire Alarms	400		
			2160	
	INSTALLATION OF AUTOMATIC TRAFFIC SIGNALS.—			
1341	Golders Green Cross Roads		950	
	FURNITURE, EQUIPMENT AND PLANT.—			
83	Gauging Apparatus (Sewers)	75		
84	Motor Pump (Sewers)	25		
—	Mechanical Shovel—Destructor Works	475		
1404	Appliances—Air Raid (Fire) Precautions	450		
—	Radiograms, etc., for Schools (Contribution)	*200		
—	Dual Locker Desks (Schools)	*200		
—	Physical Training Equipment (Schools)	*1675		
—	Dental Equipment (School Clinics)	*400		
			3500	
			14463	

Carried forward

* Education Account—£2475

Outlay on Permanent and Semi-Permanent Works (other than Repairs and Replacements) included in Estimates, 1939/40—Continued.

		RECOVERABLE ITEMS.		
Estimate Item.		£	£	£
	Brought forward			14463
ROADWAYS AND SEWERS.—				
1206/1224	Improvement Works on County Roads (from Middlesex County Council)		4109	
INSTALLATION OF AUTOMATIC TRAFFIC SIGNALS.—				
1341	From Middlesex County Council		950	
FURNITURE AND EQUIPMENT.—				
1404	Air Raid Precautions (from Home Office)		270	
—	Education Account (from Board of Education).—			
	Radiograms, etc.	40		
	Dual Desks	40		
	Physical Training Equipment	335		
	Dental Equipment	80		
			495	
				5824
				<u>£8639</u>

Items Covered by Loan Sanctions.

Estimate Item.	Loan Sanction.			
	£			
ROADWAYS AND SEWERS.—				
1252	—	Frontage—Devonshire Road	150	
1252a	—	Frontage—Southover	581	
1253	16327	Frontage—Wildwood Road (1/6th cost)	525	1256
PARKS AND OPEN SPACES—LAY-OUTS, ETC.—				
498	1150	Lay-out—York Park (1/7th cost)	131	
839	450	Lay-out—Courtway Open Space (1/7th cost)	57	188
				<u>£1444</u>

SUMMARY.

	£
Items not Covered by Loan Sanctions	8639
Items Covered by Loan Sanctions	1444
	<u>£10083</u>

York
avenue

£

500

420

1050

574

1230

2160

950

3500

4453

Capital Works (Provisional) Estimates 1939/40.

Item.	Per Borough Engineer.		Provision in M.C.C. Estimates 1939/40.	Item.
	Total Estimated	1939/40		
	Cost.	Estimate.		
	1.	2.	3.	
	£	£	£	
COUNTY ROADS.—				
Special Maintenance Works.—				
1	North End Road	14000	14000	7
2	Cricklewood Lane	16000	11000	8
3	Finchley Road	31000	19000	
4	Golders Green Road	334	334	9
Special Grant.—				
Improvement Works.—				
5	Mill Hill Broadway	43600	30000	11
6	Marsh Lane	50	50	12
7	Deans Lane Bridge	7100	7100	13
Widening Improvements, etc.—				
8	The Burroughs	750	750	14
9	The Burroughs	600	600	15
10	Station Road	10000	10000	16
11	Finchley Road	25000	25000	17
12	Cricklewood Lane Bridge	65000	30000	18
13	North End Road	5000	5000	19
14	Parson Street	3500	3500	20
15	Selvage Lane Bridge	17000	17000	21
16	Hammers Lane	13500	12303	
17	Bittacy Hill Bridge	21000	21000	
18	Marsh Lane and Hendon Wood Lane	1250	1250	22
19	Traffic Signals, Refuges, etc.	2400	2400	
		<u>£277084</u>	<u>£210287</u>	<u>£203277</u>

OBSERVATIONS.

For purposes of the Hendon Corporation Estimates the following Deductions are made from Column 2:—

Total per Column 2.....	£ 210287
Item 11—Retentions, etc.	4610
Amount taken to the Hendon Corporation Estimates	<u>£205677</u>

Item.	Total Estimated Cost.		Estimated Outlay 1939/40.
	Brought forward from previous year.	Included for 1939/40.	
	1.	2.	
	£	£	£
LOCAL ROAD, ETC., IMPROVEMENTS.—			
1	Edgwarebury Lane	1600	1600
2	Edgwarebury Lane	—	1400
3	Edgwarebury Lane	9500	8850
4	Frith Lane Bridge	7350	9400
5	Page Street	15000	15000
6	Page Street Bridge	7000	9000
	Carried forward	<u>40450</u>	<u>45250</u>

A sub
Charges of

Capital Works (Provisional) Estimates, 1939/40 (continued).

Item.	Total Estimated Cost.			
	Brought forward from previous year.	Included for 1939/40.	Estimated Outlay 1939/40.	
	1. £	2. £	3. £	
	Brought forward	40450	45250	45250
SEWERS, ETC.—				
7	Edgware Main Drainage (2nd Section)			
8	North Circular Road	9900	9900	4900
PRIVATE STREET IMPROVEMENTS.—				
9	Accommodation Road, West Heath Drive to Finchley Road; Footpath, Sturgess Avenue to Park Road		4254	4254
10	Devonshire Road, Aberdare Gardens, Osborne Gardens, Devonshire Crescent	814	1350	1350
11	Manor Hall Avenue, Manor Hall Drive	—	7000	7000
12	Hillside Gardens (part)	—	3129	3129
13	Talbot Crescent, Woodward Avenue	—	290	290
		—	3972	3972
PARKS AND PLEASURE GROUNDS.—				
Edgwarebury Park.—				
14	Bowling Greens	—	1250	1250
15	Tennis Courts	—	1200	1200
16	Land Purchases	—	94500	20000
17	Lyndhurst Park—Lay-out	—	2600	1000
18	Sunny Hill Park—Bowling Green	—	1600	1600
19	West Hendon Playing Fields—Buildings	—	2500	2500
20	Woodcroft Park—Shelter	—	510	510
PUBLIC BUILDINGS AND OFFICES.—				
21	Burroughs Property	—	6150	6150
PUBLIC DEPOTS, ETC.—				
22	Stables	—	3500	3500
FIRE STATIONS AND APPLIANCES.—				
23	Hendon Way Station	—	65000	32500
24	Fire Alarm System	—	5000	2500
ISOLATION HOSPITAL.—				
25	Surgical Unit	—	3200	3200
PUBLIC CONVENIENCES.—				
26	Temple Fortune	—	3500	3500
HOUSING.—				
27	Brent Hill Scheme (No. 4)	—	65000	32500
		<u>£51164</u>	<u>£330655</u>	<u>£182055</u>
SCHOOL BUILDINGS AND FURNITURE.—				
28	Broadfields Avenue	23280	23280	11250
29	Dole Street	23280	26763	6000
30	Edgware Senior—Reconstructions	19428	19428	18678
SCHOOL SITES.—				
31	Broadfields Avenue	8000	8000	8000
		<u>£73988</u>	<u>£77471</u>	<u>£43928</u>
SUMMARY.			£	
COUNTY ROADS (per Borough Engineer's Estimate, as adjusted)			205677	
LOCAL SERVICES			182055	
EDUCATION SERVICES			43928	
			<u>£431660</u>	

A sum of £4,206 (including £1,237 for Education) has been provided in the rate estimates in respect of Loan Charges on projected Capital Outlay and further advances in respect of works recently completed.

PUBLIC HEALTH AND JOINT MEDICAL SERVICES.
Apportionment of Estimated Costs, 1939/40.

	General Health Service. £	Maternity and Child Welfare £	School Medical Services. £	Total. £
SALARIES AND FEES.—				
Medical Officer and Assistant Medical Officers	1000*	1787	1987	4774
Dentists	—	245	2205	2450
Dental Attendants	—	58	510	568
Health Visitors	—	2142	1797	3939
Midwives	—	1350	—	1350
Sanitary Inspectors (General)	2595	—	—	2595
Sanitary Inspector (Diseases of Animals Acts)	25	—	—	25
Clerical Staff	1292*	898	1250	3449
Anæsthetist	—	39	350	389
Oculist	—	—	350	350
Doctors' Fees	—	200	110	310
	4912	6719	8568	20199
* Less Included for Isolation Hospital	479	—	—	479
	4433	6719	8568	19720
MEDICAL, ADMINISTRATIVE AND HEALTH VISITING SERVICE.—				
Superannuation Contributions and National Insurance	235	248	412	895
Wages	637	—	—	637
Uniforms	10	52	75	137
Fares and Expenses	270	160	160	590
Rent of Rooms—Town Hall	660	330	330	1320
Rent of Clinics	—	—	1720	1720
Disinfectants and Sanitary Appliances	150	—	—	150
Printing, Stationery and Postages	280	325	400	1005
Fees for Notifications and Tests	700	—	—	700
Office Furniture and Equipment	25	15	—	40
Diphtheria Immunisation	500	—	—	500
Treatment of Verminous Premises	200	—	—	200
Expenses under Housing Act, 1936	110	—	—	110
Telephone Service and Sundries	25	—	—	25
Upkeep of Motor Vans and Ambulances	600	—	—	600
HEALTH CENTRES.—				
Upkeep of Centres	—	2091	675	2766
Medical Requisites and Dressings	—	100	450	550
Carried forward	8835	10040	12790	31665

MILK,
Dro
Ass
Car

TREAT

Ort

Der

Vis

Con

Opt

Tor

Rus

Ort

Not

Tre

Con

Hos

VOLUN

Con

Day

Gra

MIDWI

Sup

Con

Ret

Uni

Tra

Tel

Dro

Law

Pri

Doc

Wa

DISEA

Sup

Pri

Outla

Outla

Outla

Outla

LOAN

Public Health and Joint Medical Services—Continued.

Total		General Health Service.	Maternity and Child Welfare	School Medical Services.	Total.
£	Brought forward	£	£	£	£
		8835	10040	12790	31665
	MILK, DRUGS, DRIED MILK, ETC.—				
	Drugs, Dried Milk, etc., for Sale	—	2150	—	2150
474	Assisted Milk Supply	—	1550	—	1550
2459	Carriage and Sundries	—	8	—	8
56					
3939	TREATMENT.—				
	Orthopædic Defects	—	280	800	1080
1350	Dental Defects (M. & C.W. Cases)	—	265	—	265
2565	Visual Defects	—	20	—	20
25	Convalescent Treatment	—	100	—	100
3449	Optical Treatment (Hospitals)	—	—	50	50
389	Tonsils and Adenoids	—	—	450	450
350	Russell Cotes School	—	—	450	450
310	Orthoptic Treatment of Squint	—	—	200	200
	North Western Child Guidance Clinic	—	—	130	130
20169	Treatment of Puerperal Fever, etc.	—	100	—	100
479	Consultations, etc.—Complicated Labour	—	10	—	10
19729	Hospital Provision (Maternity)	—	200	—	200
	VOLUNTARY ASSOCIATIONS.—				
	Contribution to Day Nursery	—	350	—	350
895	Day Nursery—Upkeep of Buildings	—	20	—	20
637	Grant to Nursing Associations	—	300	—	300
137	MIDWIFERY SERVICE.—				
500	Superannuation Contributions and National Insurance	—	80	—	80
1329	Compensation to Midwives—Loss of Practice	—	750	—	750
1720	Rent Allowance	—	78	—	78
150	Uniforms	—	60	—	60
1005	Travelling Expenses	—	100	—	100
700	Telephone Service	—	48	—	48
40	Drugs, Dressings and Appliances	—	50	—	50
500	Laundry	—	25	—	25
200	Printing, Stationery and Postages	—	25	—	25
110	Doctors' Fees (Medical Aid Notes)	—	100	—	100
25	Watling Nursing Association	—	200	—	200
600	DISEASES OF ANIMALS ACT ACCOUNT.—				
	Superannuation Contributions	1	—	—	1
	Printing and Stationery	4	—	—	4
		£			
	Outlay—Page 44—Sanitation, etc.	8810	—	—	—
	Outlay—Page 44—Diseases of Animals Acts	30	—	—	—
		8840	—	—	—
	Outlay—Page 44—Maternity and Child Welfare	—	16900	—	40619
	Outlay—Page 72—School Medical Services	—	—	14870	—
		—	1542	—	1542
2766	LOAN CHARGES (see page 91)				
550		£8840	£18451	£14870	£42161
31665	Gross Outlay				

Public Health and Joint Medical Services—Continued.

	General Health Service. £	Maternity and Child Welfare £	School Medical Services. £	Total. £
INCOME.				
MEDICAL, ADMINISTRATIVE AND HEALTH VISITING SERVICE.—				
Sanitary Officers' Salaries (from M.C.C.)	1588	—	—	1588
Fees for Disinfections and Drain Tests	90	—	—	90
Milk Retailers and Other Licences	25	—	—	25
Ambulance Fees	5	—	—	5
HEALTH CENTRES.—				
Rents charged to Education Committee	—	1720	—	1720
MILK, DRUGS, DRIED MILK, ETC.—				
Sale of Drugs, Dried Milk, etc.	—	2500	—	2500
TREATMENT.—				
Orthopædic Defects	—	20	90	110
Dental Defects	—	160	200	360
Tonsils and Adenoids	—	—	110	110
Anæsthetists Fees	—	5	—	5
Examinations—Secondary Schools	—	—	400	400
Convalescent Treatment—Fees	—	10	—	10
Sundry Fees	—	10	—	10
MIDWIFERY SERVICE.—				
Hospital Cases (Maternity) Fees	—	100	—	100
Consultants and Doctors Fees	—	40	—	40
Sale of Sterile Dressings	—	20	—	20
Midwives Fees	—	600	—	600
Grant Receivable	—	625	—	625
Miscellaneous	—	10	—	10
VOLUNTARY ASSOCIATIONS.—				
Rent—Day Nursery	—	80	—	80
Total Income	£1708	£5900	£800	£8408
SUMMARY.				
Gross Outlay	8840	18451	14870	42161
Income	1708	5900	800	8408
	£7132	£12551	£14070	£33753

Salaries and General Establishment Charges.
Apportionment of Estimated Nett Outlay to Services and Accounts.

Head of Charge.	Outlay.	Income.	Nett.
	£	£	£
Salaries	40266	4725	35541
Superannuation Contributions	5316	—	5316
Legal Expenses	1800	1445	355
Insurances and Stamp Duty	1583	150	1433
Printing, Stationery and Postages	5000	42	4958
Official Motor Cars and Cycles	1973	45	1928
Other Expenses	6620	1690	4930
Unallocated Depôt Charges	1826	—	1826
Per Details in Approved Estimates	<u>£64384</u>	<u>£8097</u>	<u>£56287</u>

Allocation to Services and Accounts.

	£	£
Sewers and Sewage Disposal	3436	
Collection and Disposal of Refuse	2114	
Hospitals and Maternity and Child Welfare	1169	
Parks, Pleasure Grounds and Open Spaces	4661	
Other Health Services	<u>1872</u>	13252
Town Planning		4134
Local Highways		9340
Fire Brigade Services		935
Street Lighting		935
Town Hall and Public Buildings		702
Public Libraries		702
		<u>30000</u>
		26287
General Establishment (Unallocated)		<u>£56287</u>

Total
£
1585
54
25
5
1720
2500
110
260
110
5
40
10
10
100
40
20
600
625
10
50
£2405
42161
5408
£30753

1938/1939.
Comparison of Estimates with Approximate Results.

ESTIMATES.				PURPOSE.				APPROXIMATE RESULTS.					
Estimated		Estimated Rate Account.						Probable		Probable Rate Account.			
Nett	Outlay.	Total.	Surplus.	Deficit.					Total.	Surplus.	Deficit.		
£	£	£	£	£					£	£	£		
	507773	—	—	—	HENDON CORPORATION				510784	—	—		
	8277	—	—	—	Less Renewals Fund Contributions				2414	—	—		
	499496	479322	—	20174	Less Exchequer Grant				508370	496247	—	12123	
	113240	113240	—	—					113240	113240	—	—	
	386256	366082	—	20174	Less Transfer to Collection Account				395130	383007	—	12123	
	—	—	—	—					9471	9471	—	—	
	386256	366082	—	20174					385659	373536	—	12123	
	498072	498831	759	—	MIDDLESEX COUNTY COUNCIL				499505	500272	767	—	
	91856	90673	—	1183	METROPOLITAN POLICE				91830	90931	—	899	
	1330	1324	—	6	ASSESSMENT COMMITTEE				1330	1303	—	27	
	977514	£956910	£759	21363	Totals				978324	£966042	£767	13049	
	956910	—	—	759	Deduct				966042	—	—	767	
	£20604	—	—	£20604					£12282	—	—	£12282	
												Deficit	
Provision to Meet Deficit as Estimated.								Approximate Results.					
	General Rate Fund Balance	—	—	£					Deficit as Estimated	—	—	£	
	Rate Appropriation Account	—	—	20174					Add Nett Outlay in Excess of Estimates	—	—	20604	
				430								810	
									Deduct Rate Yield in Excess of Estimates	—	—	21414	
												9132	
	Deficit (1938/29) as Estimated	—	—	£20604					Deficit (1938/39) Provisional	—	—	£12282	

As to Appropriation from Balances (Details, page 106).

Provisional.	General Rate Account.	Rate Appropriation Account.	Total.
£	£	£	£
Balance, 1st April, 1938	87705	610	88324
Deficit	12123	159	12282
Balance, 31st March, 1939	£75582	£460	£76042

Rates Collected and Exchequer Grant: Statement shewing amounts realised and equivalent charge per Head of Population.

Year ended 31st March.	Rates in the £ Levied.	Rate Yield and Distribution.					General Exchequer Grant.	Population.	Rate Charge per Head of Population.					General Exchequer Grant per Head.
		Other Authorities.		Local Purposes.		Total Rate Yield.			Other Authorities.		Local Purposes.		Total Rate Charge.	
		£	£	£	£				£ s. d.	£ s. d.	£ s. d.	£ s. d.		
1931	9/8	269552	59374	74450	157485	560861	86225	115682*	2 6 7	10 3	12 10	1 7 3	4 16 11	14 11
1932	9/2	280352	63569	96200	163731	603852	89957	124477	2 5 1	10 2	15 5	1 6 4	4 17 0	14 5
1933	9/-	288203	65155	112700	161101	627159	89957	129698	2 4 5	10 1	17 4	1 4 10	4 16 8	13 10
1934	9/2	321461	67377	118300	166015	673153	112159	138643	2 6 4	9 8	17 1	1 4 0	4 17 1	16 2
1935	9/2	325638	70263	131450	197615	724966	112049	146720	2 4 5	9 7	17 11	1 6 11	4 18 10	15 3
1936	9/4	360278	78681	135150	198901	773010	109692	155800	2 6 3	10 2	17 4	1 5 6	4 19 3	14 1
1937	10/-	436324	84983	146672	203462	871341	107336	162079	2 13 10	10 6	18 1	1 5 1	5 7 6	13 3
1938	10/-	452450	84994	155459	210491	903304	118357	165343	2 14 7	10 4	18 10	1 5 6	5 9 3	14 4

Population.—

* Census figure.
 Estimate of Medical Officer as at 30th June, 1932, and following years.

Rate Income Account and Rate Appropriation Account (Provisional) 1938/39.

Outlay.	£	£	Income.	£	£
Precepts payable 1938/39.—			Balance, 1st April, 1938		£ 619
Middlesex County Council	499505		Gross Rate Income	975513	
Metropolitan Police	91830		Less Cost of Rate Collection—see		
Assessment Committee	1330		Revenue Account (below)	9471	
	592665			£966042	
Transfer to General Rate Fund Account (below)		373536	Allocation.—		
		966201	Middlesex County Council	500272	
Balance (Estimated Surplus), 31st March, 1939		460	Metropolitan Police	90931	
			Assessment Committee	1303	
			General Rate Fund	373536	
				966042	
		£966661			£966661

General Rate Fund Revenue Account (Provisional) 1938/1939.

Outlay.	Estimates page.	£	£	Income.	Estimates page.	£	£
Committee Outlay.—				Balance, 1st April, 1938			£ 87705
Buildings and Town Planning	1	940		Committee Income.—			
Public Libraries	3	16460		Buildings and Town Planning	1	44	
Works and Fire Brigade	14	70602		Public Libraries	3	1524	
Estates, Parks, etc.	39	29554		Works and Fire Brigade	14	11879	
Public Health	48	39978		Estates, Parks, etc.	39	8557	
Highways	60	118618		Public Health	48	11876	
Air Raid (Fire) Precautions	62	2094		Highways	60	38471	
Finance and General Purposes	68	184665		Air Raid (Fire) Precautions	62	1256	
Higher Education (Rate Aid)	84	1200		Finance and General Purposes	68	43206	
Elementary Education (Rate Aid)	84	152500				116813	
Housing (Contributions)	84	10986		Transfer from Rate Income Appropriation			
		627597		Account (above)		373536	
Less Contributions to Re-				General Exchequer Grant			113240
newals Fund (suspended							
in 1938/39)		2414					
		625183					
Less Cost of Rate Collection							
—see Rate Appropriation							
Account (above)		9471					
		615712					
Balance—31st March, 1939			75582				
			£691294				£691294

BOROUGH OF HENDON.

Small Dwellings Acquisition Acts. Estimated Revenue Account, 1939/40.

Expenditure.			Income.				
	£	s. d.		£	s. d.	£	s. d.
Interest on Loans	1830	0 0	Balance, 1st April, 1939			2539	0 0
Insurance Premiums	125	0 0	Interest on Advances	1800	0 0		
Stamp Duties and Other Disbursements	20	0 0	Insurance Premiums Recoverable	125	0 0		
Salaries	72	0 0	Survey Fees	20	0 0		
Printing, Stationery and Postages	45	0 0	Sale of Regulations, etc.	1	0 0		
		2092	Legal Expenses (including Stamps, etc.) Recoverable	30	0 0		
Estimated Surplus, 31st March, 1940	2423	0 0				1976	0 0
		<u>£4515</u>				<u>£4515</u>	<u>0 0</u>

(Charges for repayment of Principal are provided out of Capital Repayments by Borrowers.)

Private Street Improvements. Estimated Revenue Account, 1939/40.

Expenditure.			Income.				
	£	s. d.		£	s. d.	£	s. d.
Interest on Loans	2361	0 0	Balance, 1st April, 1939			5403	0 0
Exemptions, Allowances and Other Charges	1000	0 0	Supervision Charges	1500	0 0		
		3361	Interest Chargeable to Frontagers	1425	0 0		
Estimated Surplus, 31st March, 1940	5002	0 0	Fees—Copy Agreements, etc.	35	0 0		
		<u>£8363</u>				2960	0 0
						<u>£8363</u>	<u>0 0</u>

General Insurance Fund. Hendon U.D.C. Act, 1929 (Sec. 179). Estimated Revenue Account, 1939/40.

Expenditure.			Income.				
	£	s. d.		£	s. d.	£	s. d.
Claims	50	0 0	Balance, 1st April, 1939			8855	0 0
Estimated Surplus, 31st March, 1940	10758	0 0	Commissions, Discounts, etc.	580	0 0		
		<u>£10808</u>	Premiums charged to Accounts	1100	0 0		
			Interest	273	0 0		
						1953	0 0
						<u>£10808</u>	<u>0 0</u>

BOROUGH OF HENDON.

Summary of Returns to Ministry of Health of Houses brought into Rating (not including Corporation Houses).

Period.	Totals.	Rateable Values.			Per cent- age of Values to £35.	Per cent- age of Values over £35.
		Not Exceeding £35.	£36 to £70.	Over £70.		
31st March, 1939	857	632	215	10	74%	26%
31st March, 1938	878	618	214	46	70%	30%
31st March, 1937	1836	1251	544	41	68%	32%
31st March, 1936	1986*	1303	595	88	65%	35%
31st March, 1935	946	666	259	21	71%	29%
31st March, 1934	705	503	167	35	71%	29%
31st December, 1933	75	48	20	7	64%	36%
30th September, 1933	759	541	190	28	71%	29%
31st March, 1933	499	271	178	50	54%	46%
30th September, 1932	647	418	194	35	64%	36%
31st March, 1932	1053	845	176	32	80%	20%
30th September, 1931	1030	815	174	41	79%	21%
31st March, 1931	1069	857	183	29	80%	20%
30th September, 1930	770	564	177	29	73%	27%
TOTALS	13110	9332	3286	492	71%	29%

* Includes 288 houses on Hampstead Borough Council's "Westcroft" Estate.

Analysis of Returns—1923 to 1927.

Period.	Totals.	Rateable Values.			Per cent- age of Values to £35.	Per cent- age of Values over £35.
		Not Exceeding £35.	£36 to £70.	Over £70.		
30th September, 1923	660	130	459	71	20%	80%
31st March, 1924	596	205	350	41	34%	66%
30th September, 1924	572	199	336	37	35%	65%
30th September, 1925	500	185	279	36	37%	63%
31st March, 1925	363	155	181	27	42%	58%
31st March, 1926	1068	424	576	68	40%	60%
31st March, 1927	1026	552	422	52	54%	46%
TOTALS	4785	1850	2603	332	37%	63%

For further details see pages 113-114.

ESTIMATE OF RATEABLE VALUES AND RATE PRODUCT to 31st March, 1940.

Rateable Values—March, 1933, to 31st March, 1939:

	Hendon Area.	Edgware Area.	Total.	Increase in 12 months.
Reduced Rateable Value, 31st March, 1933	£1400130	£107514	£1507644	£82924
Reduced Rateable Value, 31st March, 1934	£1517263	£121158	£1638401	£130757
Reduced Rateable Value, 31st March, 1935	£1584940	£137533	£1722473	£84072
Reduced Rateable Value, 31st March, 1936	£1649757	£149987	£1799744	£77271
Reduced Rateable Value, 31st March, 1937	£1697574	£173257	£1870831	£71087
Reduced Rateable Value, 31st March, 1938	£1729369	£187082	£1916451	£45620
Reduced Rateable Value, 31st March, 1939	£1763221	£199015	£1962236	£45785

Estimate of Reduced Rateable Value to 31st March, 1940:

	Total. £	Productive Value. £
Reduced Rateable Value per Valuation List, including 64th Proposal List	1962236	1962236
Add:—Estimated Nett Increase in Values from 1st April, 1939, to 31st March, 1940, not all of which will be fully productive	37764	20050
Estimated Reduced Rateable Value, 31st March, 1940	£2000000	£1982285

Estimate of Produce of 1d. Rate to 31st March, 1940:

1d. in the £ on Estimated Value of £1,962,236	£ 8176
1d. in the £ for Supplementals	84
	8260
Less: For Reductions on Appeals, Voids, Losses and Cost of Collection	460
Estimated 1d. Rate Produce, 31st March, 1940	£7800

Year Ended 31st March.	Gross Rate Income	Voids, etc., and Collection Expenses.	Nett Rate Income.	Rates in £.					Product of 1d. Rate. £
				Other Authorities.	Local Purposes.	Gross Rates.	Less Exchequer		
							Grant.	Total.	
s. d.	s. d.	s. d.	s. d.	s. d.	s. d.				
1933	668362	41203	627159	5 1	5 2	10 3	1 3	9 0	5807
1934	709849	36696	673153	5 4	5 4	10 8	1 6	9 2	6120
1935	775086	50120	724966	5 0	5 7	10 7	1 5	9 2	6591
1936	824746	51736	773010	5 4	5 4	10 8	1 4	9 4	6902
1937	927351	56010	871341	6 0	5 3	11 3	1 3	10 0	7261
1938	952201	48807	903394	6 0	5 3	11 3	1 3	10 0	7528
1939*	1021880	55848	966042	6 5	5 4	11 9	1 3	10 6	7667
1940*	1089660	60060	1029600	6 9	5 5	12 2	1 2	11 0	7800
Increase in Rates since 1933				1-8	3	1-11 (Dr.) 1	2-0		

* Provisional.

Details of Rates Levied to 31st March, 1940.

Purposes for which the General Rate for Twelve Months to 31st March, 1940, was made ; estimated sum required for each purpose ; and approximate pence in the £ now levied.

The following statement shows how the rate demanded is made up. It sets out the rate in the pound which would be required to meet the nett expenses of each of the principal services, after allowing for specific Government Grants towards the expenses of the services marked * but without allocation to particular services, of the Government Grants under the Local Government Acts, 1929 and 1937.

The Government Grants under the Acts of 1929 and 1937, being in aid of local government expenses generally, cannot be allocated to any particular service. They reduce, by the amount shown, the total rate in the pound which would otherwise be demanded.

Services Administered by the Council of the Borough of Hendon.			Services Administered by the Middlesex County Council.		
SUM REQUIRED to 31st March, 1940.	PURPOSES	Pence in £ now levied	SUM REQUIRED to 31st March, 1940	PURPOSES	Pence in £ now levied
£	PUBLIC HEALTH.—		£	*HIGHER EDUCATION	8.50
19675	*Sewers and Sewage Disposal	2.52	66300	PUBLIC HEALTH & PUBLIC ASSISTANCE	34.11
36340	Collection and Disposal of House Refuse	4.66	266043	*HIGHWAYS AND BRIDGES	8.25
28750	*Hospital, Maternity and Child Welfare	3.68	31145	MENTALLY DEFECTIVE AND MENTAL HOSPITALS	3.99
59429	*Parks, Pleasure Grounds and Open Spaces	7.62	17215	COUNTY BUILDINGS, OPEN SPACES AND RIVERS	2.21
20365	Other Health Services	2.61	1560	*REGISTRATION OF ELECTORS20
164559		21.09	46800	*W E S T M I D D L E S E X D R A I N - A G E	6.00
14092	*HOUSING AND TOWN PLAN- NING	1.81	7324	CONTRIBUTION — GENERAL EXCHEQUER GRANT94
1393	*TRUNK & COUNTY ROADS18	7145	*AIR RAID PRECAUTIONS91
75850	*LOCAL HIGHWAYS	9.73	50684	OTHER SERVICES	6.50
21125	FIRE BRIGADE AND APPLI- ANCES	2.72	558574		71.61
35300	STREET LIGHTING	4.52	18814	<i>Deduct—Proceeds of Local Taxa- tion Licences and Appropria- tion from Balances</i>	2.41
9218	TOWN HALL AND OFFICES	1.18			
26287	GENERAL ESTABLISHMENT	3.37	£339760	Taken to Summary	69.20
20168	PUBLIC LIBRARIES	2.58			
1940	*AIR RAID PRECAUTIONS (FIRE SERVICES)25			
152500	*ELEMENTARY EDUCATION	19.55			
1300	*HIGHER EDUCATION16			
523732	Total Expenses	67.14			
17563	<i>Deduct — Appropriation from Balances</i>	2.25			
£506169	Taken to Summary	64.89			
	Services Administered by Other Precepting Authorities.				
£			SUM REQUIRED	Summary.	Pence in £
93532	*METROPOLITAN POLICE	11.99	£	Council of the Borough of Hendon	61.89
1023	CENTRAL MIDDLESEX ASSESSMENT COMMITTEE13	506169	Middlesex County Council	69.20
£94555	Taken to Summary	12.12	339760	Metropolitan Police	11.99
			1023	Assessment Committee13
			1140484		146.21
			110884	<i>Deduct—Exchequer Grants under Local Government Acts, 1929 and 1937</i>	14.21
			£1029600	Rate in Pound Payable by Rate- payer.	132.00
				11s. 0d. in the £.	

Detailed Comparison of Nett Requirements from Rates.

Particulars. (Including Loan Charges).	Estimated Nett Amount.		Comparison— Col. 1 with Col. 2.	
	1938/39. (1).	1939/40. (2).	Increases. (3).	Decreases. (4).
	£	£	£	£
LOCAL PURPOSES.—				
PUBLIC HEALTH.—				
Sewers and Sewage Disposal	17,837	19,675	1,838	—
Collection and Disposal of House Refuse	31,529	36,340	4,811	—
Hospital, Maternity and Child Welfare	26,653	28,750	2,097	—
Parks, Pleasure Grounds and Open Spaces	57,955	59,429	1,474	—
Other Health Services	20,390	20,365	—	25
	<u>154,364</u>	<u>164,559</u>	<u>10,220</u>	<u>25</u>
HOUSING AND TOWN PLANNING	13,829	14,092	263	—
TRUNK AND COUNTY ROADS	1,352	1,393	41	—
LOCAL HIGHWAYS	71,140	75,850	4,710	—
STREET LIGHTING	32,138	35,300	3,162	—
FIRE BRIGADE AND APPLIANCES	16,687	21,125	4,438	—
TOWN HALL AND OFFICES	8,626	9,218	592	—
GENERAL ESTABLISHMENT	26,280	26,287	7	—
PUBLIC LIBRARIES	19,380	20,168	788	—
AIR RAID PRECAUTIONS (FIRE PROTECTION)	2,000	1,940	—	60
ELEMENTARY EDUCATION	152,500	152,500	—	—
HIGHER EDUCATION	1,200	1,300	100	—
	<u>499,496</u>	<u>523,732</u>	<u>24,321</u>	<u>85</u>
Deduct: Appropriation from Balances	13,814	17,563	—	3,749†
	<u>485,682</u>	<u>506,169</u>	<u>24,321</u>	<u>3,834</u>
PRECEPTS OF OTHER AUTHORITIES.—				
MIDDLESEX COUNTY COUNCIL	498,831	539,760	40,929	—
METROPOLITAN POLICE	90,673	93,532	2,859	—
CENTRAL MIDDLESEX ASSESSMENT COMMITTEE	1,324	1,023	—	301
	<u>1,076,510</u>	<u>1,140,484</u>	<u>68,109</u>	<u>4,135</u>
Deduct:—				
GENERAL EXCHEQUER GRANT	113,240	110,884	2,356*	—
	<u>£963,270</u>	<u>£1,029,600</u>	<u>70,465</u>	<u>£4,135</u>
			<u>4,135</u>	Less.
			<u>£66,330</u>	Nett.

† Increased Income.
* Decreased Income.

SUMMARY OF RATEABLE VALUES, 1936/1939.

	1936.		1937.		1938.		1939.	
	Numbers.	Per cent.	Numbers.	Per cent.	Numbers.	Per cent.	Numbers.	Per cent.
Hereditaments.								
Residences:—								
R.V. £30 and under.....	18315	47.8	20243	47.8	20699	47.7	21266	47.0
R.V. over £30	16543	43.1	18453	43.5	18897	43.6	19415	43.7
	34858	90.9	38696	91.3	39596	91.3	40681	91.6
Corporation properties	91	.3	93	.2	92	.2	100	.2
Crown properties	68	.2	68	.2	69	.2	71	.2
De-rated properties	100	.3	103	.2	104	.2	104	.2
Other	3227	8.3	3420	8.1	3517	8.1	3454	7.8
	38344	100.0	42380	100.0	43378	100.0	44410	100.0
Rateable Value.								
Residences:—								
R.V. £30 and under.....	393709	21.9	440648	23.6	452495	23.6	466855	23.8
R.V. over £30	850820	47.2	940817	50.3	963285	50.3	980233	49.9
	1244529	69.1	1381465	73.9	1415780	73.9	1447068	73.7
Corporation properties	23884	1.3	17715	.9	17707	.9	19036	1.0
Crown properties	26343	1.5	30931	1.7	31101	1.6	33146	1.7
De-rated properties	59428	3.3	53066	2.8	52472	2.8	53506	2.7
Other	445560	24.8	387654	20.7	399391	20.8	409480	20.9
	£1799744	100.0	£1870831	100.0	£1916451	100.0	£1962236	100.0
Population—								
As estimated at June in preceding year	146720		155800		162079		165343	
Rateable Value per head	£12.267		£12.008		£11.824		£11.868	
Number of persons per residence	4.209		4.026		4.093		4.064	
Average R.V.								
All Hereditaments	£46 18 9		£44 2 11		£44 3 7		£44 3 8	
Residences	£35 14 1		£35 14 0		£35 15 1		£35 11 5	

1939/40—DISTRIBUTION OF RATE BURDEN.

Purpose.	Residences.	Other Properties.	Total.
	(73.7%).	(26.3%).	
	£	£	£
Hendon Corporation	373047	133122	506169
Middlesex County Council	307803	141957	539760
Metropolitan Police	68933	24599	93532
Assessment Committee	754	269	1023
	840537	299947	1140484
Less Exchequer Grant	81722	29162	110884
Amount to be Raised	£758815	£270785	£1029600

Analysis and Total of Rateable Values as at 31st March,

	Up to £20.		£21 to £30.		£31 to £35.		£36 to £40.		£41 to £50.		No.	Value.
	No.	Value. £	No.	Value. £	No.	Value. £	No.	Value. £	No.	Value. £		
Private Houses	4227	71342	11392	290466	3674	120638	2657	100738	4085	183890		
Flats	2688	37824	1654	42972	730	24014	439	16734	859	39163		
Shops with Houses			15	419	8	267	9	356	57	2570		
Lock-up Shops	30	412	74	1914	41	1461	60	2317	145	6607		
Corporation Houses	873	14763										
Corporation Flats	105	1576										
TOTALS	7923	£125917	13447	£343244	4456	£146383	3165	£120145	5446	£232230		

CORPORATION UNDERTAKINGS:—

	No.
Schools and Playing Fields	21
Caretakers' Houses and Bungalows	16
Depôts	3
Stables	1
Refuse Disposal Works	1
Town Hall	1
Mortuary	1
Public Libraries	3
Fire Stations	2
Firemen's Houses and Flat	19
Welfare Centres, Clinics and Hospital	6
Slipper and Swimming Baths	3
Public Conveniences	7
Cottages, Bungalows and Lodges	16

STATUTORY UNDERTAKINGS:—

	No.
Electricity	13
Water	4
Gas	12
Trolley-Bus Depôt, etc.	3
Railways	13

MISCELLANEOUS:—

	No.
Crown Properties	71
Tithes	15
Metropolitan Police Stations and College	17
Garages	439
Petrol Service Stations	26
Stables and Yards	50
Sports and Tennis Grounds	75
Offices	171
Land and Garden Plots	155
On-licensed Premises	37
Off-licensed Premises	30
Workshops	150
Advertisement Stations, Hoardings, etc.	220
Halls	56
Banks	42
Warehouses and Depositories	10
Private Schools	21
Public and Secondary Schools	18
Clubs	23
Cinemas and Theatres	11
Refreshment Bars and Huts	37
Stores and Store Yards	172
Homes and Convents	35
Golf Links	3
Hotels	4
Factories and Laundries	91
Hospitals	11
Cemeteries and Crematoriums	8
Bread and Milk Depôts	7
Unclassified	87

Total to 31st March

SUMMARY OF RATEABLE VALUES, 1

	1936.		1937.		1938.
	Numbers.	Per cent.	Numbers.	Per cent.	
Hereditaments.					
Residences:—					
R.V. £30 and under.....	18315	47.8	20243	47.8	20699
R.V. over £30	16543	43.1	18453	43.5	18897
	34858	90.9	38696	91.3	39596
Corporation properties	91	.3	93	.2	92
Crown properties	68	.2	68	.2	69
De-rated properties	100	.3	103	.2	104
Other	3227	8.3	3420	8.1	3517
	38344	100.0	42380	100.0	43378
Rateable Value.					
Residences:—	£	Per cent.	£	Per cent.	£
R.V. £30 and under.....	393709	21.9	440648	23.6	452495
R.V. over £30	850820	47.2	940817	50.3	963285
	1244529	69.1	1381465	73.9	1415780
Corporation properties	23884	1.3	17715	.9	17707
Crown properties	26343	1.5	30931	1.7	31101
De-rated properties	59428	3.3	53066	2.8	52472
Other	445560	24.8	387654	20.7	399391
	£1799744	100.0	£1870831	100.0	£1916451
Population—					
As estimated at June in preceding year	146720		155800		162079
Rateable Value per head	£12.267		£12.008		£11.824
Number of persons per residence	4.209		4.026		4.093
Average R.V.					
All Hereditaments	£46 18 9		£44 2 11		£44 3 7
Residences	£35 14 1		£35 14 0		£35 15 1

Up to £20.		£21 to £30.	
No.	Value.	No.	Value.
4227	71342	11302	290466
2688	37824	1654	42972
—	—	15	419
30	412	74	1914
873	14763	312	7473
105	1576	—	—
7923	£125917	13447	£343244

CORPORA

STATUTO

MISCELL

1939/40—DISTRIBUTION OF RATE BI

Purpose.	Residences. (73.7%).	Other Properti (26.3%).
	£	£
Hendon Corporation	373047	133122
Middlesex County Council	397803	141957
Metropolitan Police	68933	24599
Assessment Committee	754	269
	810537	299947
Less Exchequer Grant	81722	29162
Amount to be Raised	£758815	£270785

is and Total of Rateable Values as at 31st March, 1939.

No.	£21 to £30.		£31 to £35.		£36 to £40.		£41 to £50.		£51 and over.		Total.	
	No.	Value. £	No.	Value. £	No.	Value. £	No.	Value. £	No.	Value. £	No.	Value. £
71342	11392	290466	3674	120638	2657	100738	4085	183890	5514	394471	31549	1161545
37824	1654	42972	730	24014	439	16734	859	39163	1003	65604	7373	226311
—	15	410	8	267	9	356	57	2570	280	31788	369	35400
412	74	1914	44	1164	60	2317	145	6607	1239	130993	1592	143707
14763	312	7473	—	—	—	—	—	—	—	—	1185	22236
1576	—	—	—	—	—	—	—	—	—	—	105	1576
125917	13447	£343244	4456	£146383	3165	£120145	5146	£232230	8036	£622856	42173	£1590775

CORPORATION UNDERTAKINGS:—

	No.	Value. £		
Schools and Playing Fields	21	9775		
Caretakers' Houses and Bungalows	16	348		
Depôts	3	642		
Stables	1	100		
Refuse Disposal Works	1	1396		
Town Hall	1	1626		
Mortuary	1	48		
Public Libraries	3	1361		
Fire Stations	2	624		
Firemen's Houses and Flat	19	418		
Welfare Centres, Clinics and Hospital	6	1727		
Slipper and Swimming Baths	3	395		
Public Conveniences	7	278		
Cottages, Bungalows and Lodges	16	298		
			100	19036

STATUTORY UNDERTAKINGS:—

	No.	Value. £		
Electricity	13	52430		
Water	4	20636		
Gas	12	16352		
Trolley-Bus Depôt, etc.	3	457		
Railways	13	15436		
			45	105311

MISCELLANEOUS:—

	No.	Value. £		
Crown Properties	71	33146		
Tithes	15	491		
Metropolitan Police Stations and Collego	17	6713		
Garages	439	20884		
Petrol Service Stations	26	13490		
Stables and Yards	50	1316		
Sports and Tennis Grounds	75	5499		
Offices	171	9354		
Land and Garden Plots	155	970		
On-licensed Premises	37	10984		
Off-licensed Premises	30	3462		
Workshops	150	6664		
Advertisement Stations, Hoardings, etc.	220	5482		
Halls	56	2532		
Banks	42	8330		
Warehouses and Depositories	10	4161		
Private Schools	21	6818		
Public and Secondary Schools	18	6507		
Clubs	23	4357		
Cinemas and Theatres	11	14577		
Refreshment Bars and Huts	37	970		
Stores and Store Yards	172	6192		
Homes and Convents	35	11886		
Golf Links	3	1838		
Hotels	4	3753		
Factories and Laundries	91	38070		
Hospitals	11	7325		
Cemeteries and Crematoriums	8	4788		
Bread and Milk Depôts	7	2213		
Unclassified	87	4342		
			2092	247114

Total to 31st March, 1939... 44410 £1962236



These digital images are
the copyright of
The London Borough of
Barnet 2017

Tha
Coun
Apri
Burro
Counc

Town



Borough of Hendon.

NOTICE IS HEREBY GIVEN

That a Special Meeting of the Council of the Borough of Hendon, in the County of Middlesex, will be held on **Monday** next, the **24th** day of **April, 1939**, at **6** o'clock in the afternoon, at the Town Hall, The Burroughs, Hendon, N.W. 4, and all and several the Members of the said Council are hereby summoned to attend.

The business to be transacted at such meeting is as follows:—

To approve, or otherwise, the Report of the Air Raid Precautions Committee
(19/4/39—to follow).

Town Clerk.

Town Clerk's Office,
Hendon, N.W. 4.

19th April, 1939.

K
L
M
N
O
P
Q
R
S
T
U
V
W
X
Y
Z

TH
in
day
Bu
Co



Borough of Hendon.

NOTICE IS HEREBY GIVEN

That an Ordinary Meeting of the Council of the Borough of Hendon, in the County of Middlesex, will be held on **Monday** next, the **8th** day of **May, 1939**, at **6** o'clock in the afternoon, at the Town Hall, The Burroughs, Hendon, N.W. 4, and all and several the Members of the said Council are hereby summoned to attend.

The business to be transacted at such meeting is as follows:—

1. To confirm Minutes of the Special Meetings of the Borough Council held on the 17th and 24th April, 1939.
2. Official Announcements.
3. Report of Town Clerk on election to fill Casual Vacancy—Central Ward.
4. To fill vacancies on the following Standing Committees of the Council:—
 - Estates, Parks and Allotments Committee.
 - Libraries and Local Pensions Committee.
 - Housing Committee.
5. Questions.
6. To approve, or otherwise, the Reports of the following Committees, viz.:—
 - Education; Public Health and Medical Services; Highways; Estates, Parks and Allotments; Works and Fire Brigade; Libraries and Local Pensions; Housing; Buildings and Town Planning; Rating and Valuation; Air Raid Precautions; and Finance and General Purposes.

7. To authorise the sealing of the following documents:—

Duplicate Conveyance	All Souls' College, Oxford, and the Corporation —of land at the junction of Brampton Grove and The Burroughs, Hendon.
Duplicate Conveyance	Mill Hill Homesteads Ltd., and the Corporation —of greensward opposite 8-14, Devonshire Crescent.
Agreement	The Corporation and Mr. E. E. Richardson—as to engagement of Quantity Surveyor in connection with Broadfields Avenue School.
Lease	The Corporation and Handley Page Limited— of land for use as a sports ground at Woodfield Park, Hendon.
Agreement	The Corporation and Sir Charles McRea—as to grazing rights — Arrandene Open Space, Hendon.
Transfers	Aubrey Bell Hewett, Esq., and others to the Corporation—of land on the south-west side of Hendon Wood Lane, Hendon.

8. Reports (if any) of Officers.

9. To consider the following Motion, notice of which has been duly given by Alderman W. M. Maughan, J.P., Alderman R. A. B. Teare, M.B.E., and Councillor C. F. Windust:—

“ THAT the Council's resolution (18/7/38), in reference to ex-Station Officer Stimpson, be rescinded and that Mr. R. E. Stimpson be re-instated as Station Officer in Hendon Fire Brigade.”

10. Whitsun Recess.

To RESOLVE—That His Worship the Mayor, or in his absence the Deputy Mayor, be vested with power to deal with any urgent matters which may arise during the Whitsun Recess, *i.e.*, 23rd May to the 12th June.



Town Clerk.

Town Clerk's Office,

Hendon, N.W. 4.

3rd May, 1939.

INDEX.

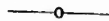

MINUTES --- --- --- --- --- --- --- --- --- --- Page 608 to 642

REPORTS:—

EDUCATION COMMITTEE --- --- --- --- --- --- --- --- --- --- „ 643 to 658

PUBLIC HEALTH & MEDICAL SERVICES COMMITTEE „ 659 to 665

HIGHWAYS COMMITTEE --- --- --- --- --- --- --- --- --- --- „ 666 to 670

ESTATES, PARKS & ALLOTMENTS COMMITTEE --- --- --- --- --- --- --- --- --- --- „ 671 to 675

WORKS & FIRE BRIGADE COMMITTEE --- --- --- --- --- --- --- --- --- --- „ 676 to 681

LIBRARIES & LOCAL PENSIONS COMMITTEE --- --- --- --- --- --- --- --- --- --- „ 682 to 683

HOUSING COMMITTEE --- --- --- --- --- --- --- --- --- --- „ 684 to 688

BUILDINGS & TOWN PLANNING COMMITTEE --- --- --- --- --- --- --- --- --- --- „ 689 to 702

RATING & VALUATION COMMITTEE --- --- --- --- --- --- --- --- --- --- „ 703 to 704

AIR RAID PRECAUTIONS COMMITTEE --- --- --- --- --- --- --- --- --- --- „ 705 to 709

FINANCE & GENERAL PURPOSES COMMITTEE --- --- --- --- --- --- --- --- --- --- „ 710 to 752

S
T
R
O
P
O
P
H
I
C
S
P
H
E
R
I
C
A
L
G
E
O
M
E
T
R
Y



Minutes.

At a Special Meeting of the COUNCIL of the BOROUGH OF HENDON, held at the Town Hall, The Burroughs, Hendon, N.W. 4, on Monday, the 17th day of April, 1939, at 6 o'clock p.m.

PRESENT:

His Worship the Mayor (Councillor H. G. Potter, J.P., F.S.I.), in the Chair.

The Deputy Mayor (Alderman S. H. Egan, J.P.).

Aldermen:

**J. J. Copestake, J.P.,
B. Flowers,**

**W. M. Maughan, J.P.,
A. J. Reynolds, J.P.,**

**F. C. Rice,
R. A. B. Teare, M.B.E.**

Councillors:

**E. Arter, M.C., M.I.A.E.,
F. H. Bate,
F. J. Collins,
H. Connell, J.P.,
E. J. Cox,
A. W. Curton,
F. W. Gilpin,
A. W. Greville,
J. Griffiths,**

**W. A. Hicks,
G. H. Hignett,
P. Lightfoot,
A. A. Naar, M.B.E.,
(Mrs.) F. E. Parvin,
G. Pinkney,
G. J. Pryke, F.I.A.C.,
A.M.I.S.E.,**

**T. Pugh,
G. R. Richardson,
J. H. Rodway,
T. J. Scott,
W. H. N. Shakespeare,
M.C., A.F.C., J.P.,
H. P. Small,
C. F. Windust.**

NOTICE OF MEETING:

The Town Clerk read the notice convening the meeting.

MINUTES—CONFIRMATION:

Moved by Alderman Maughan, seconded by Councillor Curton, and

222.—RESOLVED—That the Minutes of the Special Meeting and of the Ordinary Meeting of the Borough Council held on the 27th March, 1939, and of the Special Meeting held on the 3rd April, 1939, be confirmed.

APOLOGIES FOR ABSENCE:

Apologies for absence were submitted on behalf of Alderman B. J. Mouro and Councillor L. Hirshfield.

RECESS (EASTER) REPORT:

223.—RESOLVED—That the following report be received:—

To the Aldermen and Councillors,

HENDON BOROUGH COUNCIL.

Ladies and Gentlemen,

RECESS (EASTER) REPORT.

The following matters have been dealt with under authority of the Council's resolution No. 219 of the 27th March:—

1.—OLD AGE PENSIONS:

12 Claims, 1 Question and 1 Appeal have been considered and decisions given having the following effect:—

Claims.

7 allowed at the full rate of 10/- weekly.

1 allowed at the rate of 6/- weekly.

1 disallowed—yearly means estimated to exceed £49 17s. 6d. and no evidence of age.

1 disallowed—yearly means estimated to exceed £49 17s. 6d.

1 disallowed—unsatisfactory evidence of blindness.

1 Claim inadmissible—Claimant has not been a British subject for the last ten years.

—
12
—

Question.

Pensioner not entitled to any pension as from 10th March, 1939, inclusive, by reason of non-medical relief.

Appeal.

With regard to the Appeal, the Ministry of Health have been informed that the Local Pensions Committee have no observations to offer, but, based on the revised calculations, it is assumed that the Claimant is entitled to a pension at the rate of 10/- weekly.

2.—ARRANDENE OPEN SPACE:

I gave authority for a small piece of land on the Arrandene Open Space to be used for grazing purposes until March, 1940, at a rent of £2.

3.—RESTRICTIONS ON SALES, ETC., BY PERSONS COLLECTING, OR DEALING IN RAGS, OLD CLOTHES OR SIMILAR ARTICLES:

On a report from the Police, I authorised the Town Clerk to take proceedings against Arthur Day, 35, Palmerston Road, Forest Gate, in respect of a contravention of Section 154 of the Public Health Act, 1936, in the vicinity of Algernon Road Council School.

4.—WATLING CLINIC—DAMAGE TO WINDOWS:

I gave authority for proceedings to be instituted against three boys in respect of damage to the windows of the above Clinic on the 12th February, 1939.

5.—LIMITATION BILL:

A communication from the Association of Municipal Corporations was submitted with regard to the proposed amendment to the Public Authorities Protection Act, 1893. It did not appear that objection could be taken to the extension of the period from six months to twelve months within which proceedings against a Local Authority must be instituted, but I caused a letter to be addressed to the Member of Parliament asking him to oppose certain other amendments that would add to the difficulties of Local Authorities.

6.—DEDICATION OF LAND, CHURCH ROAD, HENDON:

I approved the acceptance of an offer by Mr. Harold Bevir to dedicate to the public free of cost a small piece of land adjoining the Odeon Cinema, and gave authority for payment of reasonable legal costs and for the Corporate Seal to be affixed to the Conveyance.

7.—LAND AT BITTACY HILL, MILL HILL:

With reference to the proposed acquisition by the Council of a piece of land bounded by Bittacy Hill, Station Villas and Bittacy Road, I gave authority as follows:—

- (i) That in view of the inability of the Council to purchase by agreement the Council pursuant to powers vested in them by Section 25 of the Town and Country Planning Act, 1932, make an Order for the compulsory acquisition of the piece of land 3,046 square yards or thereabouts in extent bounded by Bittacy Hill, Station Villas and Bittacy Road.
- (ii) That the Corporate Seal be affixed to the Plan and Order, both documents being identified by the title "Hendon Planning Scheme No. 1 (Bittacy Hill) Compulsory Purchase Order, 1939."
- (iii) That the Order be published in the manner prescribed by Part I. of the Third Schedule to the Town and Country Planning Act, 1932; and
- (iv) That the Order be submitted in due course for the confirmation of the Minister of Health.

8.—SEALING OF DOCUMENTS:

The Corporate Seal has been affixed to the following documents:—

Tenancy Agreement	The Corporation to the Golders Green Bowling Club—for the use of rooms in a building in Child's Hill Park.
Agreement	Mr. E. J. Batchelor to the Corporation—for Conveyance of land adjoining Nos. 16, 20 and 22, Church Road, Hendon.

9.—TENDERS FOR SALE OF REFRESHMENTS IN PARKS:

The following tenders for the sale of refreshments in parks for the year ending 31st March, 1940, have been accepted:—

	£	s.	d.
Woodfield Park—Mr. J. T. Enright	2	10	0
Sunny Hill Park—The Park Supplies	5	0	0

10.—LAND ADJACENT TO SCRATCHWOOD OPEN SPACE:

I considered an application received from the Officer Commanding the Eastern Command for permission for a camp to be held at week-ends between the 1st March and 30th September, 1939, for a small number of men being trained in anti-aircraft work, and gave authority for an agreement to be entered into under which the War Office will pay the sum of £1 for this privilege, and also undertake to pay any compensation in respect of any damage done by reason of the usage of the land in question.

11.—MOAT MOUNT CAMP SITE:

A plan of the proposed sanitary conveniences on this site was submitted to me, and I gave authority for this work to be put in hand at an estimated cost of £850, including the provision of a water supply to the camp site and the park itself.

12.—STABLES:

I considered a certificate received from the Veterinary Surgeon relating to horse No. 13, "Sharper," and gave authority for the horse to be destroyed.

13.—SURFACING TO PRIVATE STREETS:

A schedule of tenders received for surfacing work to the following roads was submitted to me, and I gave authority for the tenders of G. Wimpey & Co. Ltd. at 3/10d. per square yard for the surfacing to the carriageways and 3/3d. per square yard for the surfacing of the margins to footways to be accepted:—

Devonshire Road,
Devonshire Crescent,
Aberdare Gardens,
Osborne Gardens,

and for the Corporate Seal to be affixed to any necessary documents.

14.—STREET DIRECTION SIGNS:

An application from the London Passenger Transport Board for permission to change the existing sign at present on lamp standard No. 1896 at the junction of Chanctonbury Way and Lullington Garth for one of the standard type was submitted to me, and I gave authority for the necessary approval to be given.

15.—UPCROFT AVENUE, EDGWARE:

A letter from Mr. J. Williamson of 2, Upercroft Avenue, Edgware, suggesting that this road should be made up was submitted to me, and I gave authority for the necessary plans and estimates to be prepared (Section 150 of the Public Health Act of 1875).

16.—HENDON PLANNING SCHEME NO. 1:

It was reported to me that representations had been received regarding the oak tree, known as "Goldsmith's Oak," in the front gardens of the houses known as Nos. 10 and 11, Lawrence Street, Mill Hill.

In order to prevent the tree being removed or lopped without the permission of the Council, I gave authority for it to be registered under Clause 49 of the above Scheme and notices served on the owners and occupiers of the above-mentioned houses.

17.—"RAVENSFIELD" AND "FENELLA," THE BURROUGHS, HENDON:

In view of the decision taken some time ago that the Firemen should be removed to "Fenella," I have instructed the Borough Surveyor to proceed with such a moderate amount of work as is necessary in order to get "Fenella" ready for occupation by those Firemen who are now in "Ravensfield" at the earliest possible moment. This will then facilitate the removal of the Firemen from "Ravensfield" and let the British Red Cross Society have the whole of "Ravensfield" and be responsible for it.

18.—TALBOT AMBULANCE, BML 945:

Upon consideration of the Chief Fire Officer's report, the above ambulance was sent to Sunbeam-Talbot Ltd. for general overhaul, and an estimate for necessary repairs amounting to £82 2s. 0d. was submitted and approved.

It is understood that the Chief Officer proposes to report to the Works and Fire Brigade Committee on the question of additional ambulance provision.

19.—SCHOOLS—FUEL:

Owing to the intended mode of delivery and charges on the tender accepted (E.C. 14/2/39—F. & G.P.S./C., 31/1/39—8) for certain classes of fuel from C. Franklin Ltd. items (d) and (e), I approved the substitution and acceptance of the tender of J. Hudson and Co. Ltd. for the following, for the period 1/4/39 to 31/3/40:—

Scotch washed peas for automatic stokers—32/6d. per ton.

Scotch washed singles for automatic stokers—33/6d. per ton.

with the necessary variation to the Council's resolution No. 151, and authorised the Corporate Seal to be affixed to the necessary Contract.

20.—DEFECTIVE CHILDREN:

On the reports of the Medical Officer, the following cases have been dealt with:—

J.G., N.W. 2	Carditis (rheumatic)	3 months' convalescence at a suitable Heart Home and the case reviewed prior to the expiration of that period with a view to extension, if necessary.
D.M., Burnt Oak	General debility and catarrh of chest	4 weeks' convalescence at a Roman Catholic Convalescent Home.
M.M., Burnt Oak	General debility and malnutrition	4 weeks' convalescence at a Roman Catholic Convalescent Home.
A.M., Burnt Oak	Debility	2 months' convalescence.
A.M., N.W. 2	General debility and malnutrition	1 month's convalescence.
B.W., N.W. 7	Bronchiectasis	3 months' convalescence.
E.B., Burnt Oak	Blepharitis	Admission to the White Oak Hospital, Swanley, Kent.
D.B., N.W. 2	General debility after pleurisy	6 weeks' convalescence at Victoria Home, Margate.
J.M., Burnt Oak	Chronic Bronchitis and general debility	6 weeks' convalescence at a Roman Catholic Convalescent Home.
J.S., Burnt Oak	Anæmia and slightly sub-normal nutrition	4 weeks' convalescence at a Roman Catholic Convalescent Home.
R.M., N.W. 4	Mentally defective (feeble-minded)	Admission to the Special Day School for Educable Mentally Defective Children, Oak Lodge, Finchley.
A.H., Edgware	Imbecile	Notification to the Middlesex County Council under Article 2 (a) of the Mental Deficiency (Notification of Children) Regulations, 1928.

C.G., Hendon, N.W. 9.

The above child was admitted to Swiss Cottage School for the Blind on the 24th October, 1938, whilst his parents were resident in New Romney, Kent.

The parents have recently removed to an address in this area and authority has been given for financial responsibility to be accepted as from the date of the parents' removal into this area, i.e., 23rd January, 1939.

21.—NURSING HOMES REGISTRATION:

(A). *Exemptions.*

Applications have been approved from the Manor House Hospital, N.W. 11, Hendon Cottage Hospital, N.W. 4, and the Community of S. Mary at the Cross, Edgware, for exemption for a period of one year under Section 192 of the Public Health Act, 1936, to 31/3/40.

(B). *"Cartref," 196, Watford Way, N.W. 4.*

Application has been received from Mrs. G. H. Chandler for registration of the above premises as a Nursing Home under Section 187 of the Public Health Act, 1936.

Investigations having been made and satisfactory reports submitted, I authorised registration in respect of two chronic invalid persons.

22.—SMALL DWELLINGS ACQUISITION ACTS:

I have authorised the necessary steps in the issue of a Vacating Receipt arising from the premature repayment of advance S.D.A. Reference 5/R.3157.

23.—SUPERANNUATION (ACT, 1937):

A. E. Cox (Clerk of Works) retires under age limit on the 29th April, 1939. A calculation of pension made on the basis approved by the Council shews he is entitled to the sum of £63. 15s. 0d. per annum. I have authorised payment accordingly.

24.—PAY ORDERS:

The following Pay Orders have been examined and signed:—

				£	s.	d.	
No. 260	----	----	-----	3520	3	3	of 1938/39.
No. 261/6	----	----	-----	3248	10	1	of 1938/39.
No. 1	----	----	-----	6602	6	6	of 1939/40.

25.—HOUSING STUDENT:

I have interviewed Miss R. C. Brown of Wimbledon and have agreed to her employment on probation for a period of 3 months in accordance with the Council's resolution.

26.—HOUSING TENANTS:

I have approved the following allotments of houses and transfer of tenancies:—

Allotment of Council Houses.

Appln. No.	Name and Address.	Family.	House allotted.
5980*	Potter, F. J., 229, Cricklewood Lane	H. & W. 1 child	42, Clitterhouse Road.
5977	Condon, C., 76, Dartmouth Road	H. & W. 1 child	19, Riverside.
5700	Penny, H. W., 20, Ravenstone Road	H. & W. 2 children	113, Clitterhouse Road.
6216	Canning, J., 20, Meadow Gardens	H. & W. 4 children	37, Bittacy Hill.

* House to be demolished.

Transfers of Tenancies.

Appl. No.	Name.	From.	To.
4097	Rayner, A.E.	113, Clitterhouse Road	79, Clitterhouse Crescent.
5640	Gammon, E.	48, Clitterhouse Road	64, Clitterhouse Road.
3346	Jamison, G. M.	106, Park Road	48, Clitterhouse Road.
2462	Loader, B. G.	56, Park Road	106, Park Road.

27.—REQUISITIONS:

The following were submitted and approved:—

	£	s.	d.
General Stationery	219	17	3
Borough Surveyor's	153	18	1
Public Health	52	3	10
School Medical Services	37	1	11
Libraries (Bindings)	111	0	0

28.—BUILDING APPLICATIONS:

The attached statement shows the applications submitted and action taken thereon.

HERBERT G. POTTER,

Mayor.

14th April, 1939.

BUILDING APPLICATIONS.

(a) The following applications were approved:—

Appln. No.	Description and Situation.	Public Health Act, 1936.	Town Planning.	Restriction of Ribbon Development Act, 1935.
A.6633a	Plan showing revised position for garage, 145, Station Road, Hendon. Owner and Applicant—T. Rowland	Approved	Consent given Conditions:— (1) That the existing advertisement boards shall be removed (2) That the portions of the premises not built upon shall be kept in good condition	Approved.
A.7812a	House, plot 5, Tudor Close, Mill Hill. Owner and Applicant—T. C. Walker	Approved	Consent given under Clause 43 (3) two feet Conditions:— (1) That the distance between the west wall of the house and the owner's west boundary shall not be less than two feet (2) That Consent No. 422 is hereby cancelled	—
A.7956	Garage, 29, New Way Road, N.W. 9. Owner and Applicant—C. J. Cross	Approved	—	—
A.7952	Garage, 12, Beech Walk, Mill Hill (Amended application). Owner and Applicant—A. Haerdiacux	Approved	—	—
A.7959	Garage, 12, Holders Hill Crescent, Hendon (Amended application). Owner—E. Nichols. Applicant—J. Earl	Approved	—	—
A.7972	Garage, "Abbotsford," High Street, Edgware. Owner—H. Ingledew. Applicant—Highgates (Builders) Ltd.	Approved	—	—
A.7973	2 garages, plots 10 and 22, Kenilworth Road, Edgware. Owner and Applicant—Neusden Property Co.	Approved	—	—

Appl. No.	Description and Situation.	Public Health Act, 1936.	Town Planning.	Restriction of Ribbon Development Act, 1935.
A.7975	Porch, 52, Highview Avenue, Edgware. Owner—W. Carr. Applicant—Oram (Builders) Ltd	Approved	—	—
A.7978	10 houses and garages, Nos. 29-43, 40 and 42, Worcester Crescent, N.W.7. Owner an Applicant—G. Wimpey and Co. Ltd.	Approved	Consent given under Clause 43 (3) Condition:— That the distance between the north-east walls of houses Nos. 35 and 42 and the owners' north-east boundaries shall not be less than three feet, and that the distance between the south-west walls of houses Nos. 33 and 40 and the owners' south-west boundaries shall not be less than three feet	—
A.7979	Garage, 347, Watford Way, Hendon. Owner—Mrs. Knight. Applicant—Housales, Ltd.	Approved	Consent given under Clause 43 (3) Condition:— That the north wall of the garage may be erected up to the owner's north boundary	—
A.7980	Garage, 27, Ashley Lane, Hendon. Owner—A. Lunnon. Applicant—G. Ramsbotham	Approved	—	—
A.7985	Addition, 24, Sunningfields Road, Hendon. Owner—Mrs. Trotter. Applicant—T. Bowen	Approved	—	—
A.7989	Addition, 11, Brockley Avenue, Edgware. Owner and Applicant—R. & E. Davis	Approved	—	—
A.7990	Room over garage, 65, The Vale, N.W.11. Owner and Applicant—Dr. P. V. Pritchard	Approved	Consent given under Clause 43 (3) Condition:— That the distance between the south-west wall of the addition and the owner's south-west boundary shall not be less than two feet nine inches	—

Appla. No.	Description and Situation.	Public Health Act, 1936.	Town Planning.	Restriction of Ribbon Development Act, 1935.
A.7994	Garage, 32, Glenwood Road, Mill Hill. Applicant—G. Wimpey & Co. Ltd.	Approved	—	—
A.7995	Alterations, Hendon Golf Club, Holders Hill Road, Hendon. Owner—Hendon Golf Club. Applicant—Welch & Lander	Approved	—	Approved.
A.7997	Garage, 7, Saddlescombe Way, N.12. Owner and Applicant—J. J. Gayer	Approved	—	—
A.7998	Garage, 185, Hampstead Way, N.W.11. Owner—Mr. Bates. Applicant—Armitage & Son	Approved	—	—
A.7999	Alterations, 109, Station Road, Edgware. Owner—Barclays Bank Ltd. Applicant—Welch & Lander	Approved	Consent given under Clause 42 (ii) Condition:— That the proportion of site covered by buildings shall not exceed ninety-three per cent.	—
A.8001	Garage, 112, Broadfields Avenue, Edgware. Owner and Applicant—S. Lighthband	Approved	—	—
A.8003	House and garage, plot 4, Tenterden Gardens, Hendon. Owner—W. Bolton. Applicant—D. Myers	Approved.	Consent given under Clause 43 (3) Condition:— That the distance between the north-west wall of the house and the owner's north-west boundary shall not be less than three feet	—
A.8006	Extension to bedroom and kitchen, 32, Uphill Road, Hill Hill. Owner and Applicant—Miss B. A. B. Harrington	Approved.	—	—
A.8002	Air raid shelter, north-east side, Edgware Road, N.W.9. Owner and Applicant—Ever Ready Razor Products Ltd.	Approved	—	Approved.
A.7968	Lay-out of new roads and construction of private sewers in connection therewith, Edgwarebury House Estate, south-east side, Elstree Hill, Elstree. Owner—Farhills Estates Ltd. Applicant—W. F. Thorpe	Approved	Consent given under Clause 21 Condition:— That the building line for all streets shall not be less than twenty-five feet	—

(b) The following applications were not in order:—

Appln. No.	Description and Situation.	Public Health Act, 1936.	Town Planning.	Restriction of Ribbon Development Act, 1935.
A.4146	Conversion of 10, Parkside, Mill Hill, into two flats. Owner and Applicant—E. W. Leech	—	Consent refused under Clause 28	—
A.8007	Store, west side, Page Street, N.W.7. Owner and Applicant—J. Laing & Son Ltd.	Approved.	Consent refused under Clauses 28 and 43 (3)	—
(c) The following applications for portable buildings were approved for a period expiring 30th September, 1941:—				
A.7899	Conservatory, 27, Osborn Gardens, N.W.7. Owner and Applicant—A. J. Cockerell	Approved.	—	—
A.7974	Garage, Hillview Gardens, N.W.4. Owner and Applicant—British Launderers' Research Association	Approved	—	—
A.7982	Garage, 189, Colindale Avenue, N.W.9. Owner and Applicant—F. H. Godwin	Approved	—	—
A.7984	Shed, rear of Brotherhood Hall, West Hendon Broadway, N.W.9. Owner and Applicant—Royal Society for the Prevention of Cruelty to Animals	Approved	Approved (Scheme 2) Interim Development Order:— That the work shall be actively commenced within twelve months of the date of this Order	Approved.
A.7986	Extension to garage, 95, Southfields, N.W.4. Owner and Applicant—F. A. Peachey	Approved	—	—
A.7988	Garage, 145, Bittacy Rise, N.W.7. Owner and Applicant—N. T. White	Approved	—	—
A.7991	Garage, 18, Windsor Avenue, Edgware. Owner and Applicant—A. Allen	Approved	—	—
A.7993	Garage and glass lean-to, 46, Southfields, N.W.4. Owner and Applicant—S. J. Ablitt	Approved	—	—
A.8000	Garage, 73, Cumbrian Gardens, N.W.2. Owner and Applicant—H. I. Hogarth	Approved.	—	—
A.7981	Workshop, north-east side, Edgware Road, N.W.9. Owner and Applicant—Romac Motor Accessories Ltd.	Approved	Consent given under Clause 43 (3) Condition:— That the distance between the north-west wall of the new building and the owner's north-west boundary shall not be less than two feet	—

Item No. 17—Ravensfield and Fenella, The Burroughs, Hendon.

On consideration of the above item, the Town Clerk reported that His Worship the Mayor had authorised the use, subject to the consent of the County Council, of No. 1, Ravensfield for A.R.P. purposes owing to the necessity for additional accommodation and that an endeavour was being made to provide other accommodation for the British Red Cross Society.

ADOPTION OF REPORT: Moved by His Worship the Mayor, seconded by the Deputy Mayor (Alderman Egan), and

224.—RESOLVED—**That the foregoing report, as amended, be approved and adopted.**

VOTE OF THANKS TO THE MAYOR:

Moved by Alderman Maughan, seconded by Alderman Rice, and

225.—RESOLVED Unanimously—**That the warmest thanks of the Council be extended to His Worship the Mayor, for the manner in which he had carried out the official duties imposed upon him during the Easter Recess and for his comprehensive report thereon.**

REPORT OF THE AIR RAID PRECAUTIONS COMMITTEE:

Moved by Councillor Arter, seconded by Councillor (Mrs.) Parvin, and

226.—RESOLVED—**That the following report be received.**

**Report of the
Air Raid Precautions Committee**

27th March, and 12th April, 1939.

COMMITTEE:

*†Councillor E. Arter, M.C., M.I.A.E. (*Chairman*).

Aldermen:

W. R. Clemens, F.C.A.,

*J. J. Copestake, J.P.

Councillors:

*†F. H. Bate,
* F. J. Collins,
*†A. W. Curton,
†J. Griffiths,
†W. A. Hicks,

*†C. H. Hignett,
L. Hirshfield,
*†A. A. Naar, M.B.E.,
*†C. Pinkney,
H. C. Potter, J.P., F.S.I.

T. J. Scott,
†W. H. N. Shakespeare,
M.C., A.F.C., J.P.,
*†C. F. Windust.

(*Mayor*),

* denotes member present 27th March, 1939.

† denotes member present 12th April, 1939.

1.—CHIEF AIR RAID WARDEN—NOMINATIONS:

The Council on the 27th March decided that the whole of the Air Raid Wardens should be asked to nominate a Chief Warden for appointment by the Council if they think fit (Resolution No. 179) and referred to this Committee the question of the procedure to be adopted. Very full consideration has been given to the matter, and it was

RESOLVED—That the following procedure be adopted:—

- (a) A nomination paper shall forthwith be supplied to each Warden (trained or in training) on which they shall record the name and address of the persons they desire to nominate; the filled in nomination paper to be enclosed in an envelope to be provided on which the name and address of the person submitting the nomination should be written, and the envelope containing the nomination paper returned to the Town Hall in the "Reply Paid" envelope to be provided.
- (b) The closing date for the receipt of the nominations to be agreed by the Chairman.
- (c) The Town Clerk to notify each member of the Committee of the day and time fixed for opening of the envelopes and the counting of the nomination papers.

Nominations were duly counted on the 12th instant, and the nominee receiving the highest number of votes was Mr. T. Kirkland Bridge (Lt. Commander Paget intimated that he did not desire to stand for nomination).

RESOLVED—That the matter be reported to the Council for such action as they deem necessary.

2.—CO-OPTION ON AIR RAID PRECAUTIONS COMMITTEE:

RESOLVED TO RECOMMEND—That each of the following Air Raid Precautions Services be invited to appoint one representative to attend at the commencement of each meeting of the Committee in an advisory capacity in so far as the services which they represent are concerned:—

Air Raid Wardens' Organisation (The Chief Warden),
 St. John Ambulance Brigade,
 The British Red Cross Society,
 The Auxiliary Fire Service,
 Decontamination Service,
 Rescue and Demolition Service.

The question of any further co-option to the Committee will be considered by the Committee as and when necessity arises.

3.—MEETINGS OF THE COMMITTEE:

The Committee have had under consideration the question of the frequency of Meetings and decided that as far as possible meetings of the Committee should be held fortnightly, and they have asked the Town Clerk to report on the matter at the next meeting and to suggest suitable dates.

4.—APPOINTMENT OF RAID PRECAUTIONS OFFICER.

The Committee considered a schedule of 200 applications for the above appointment, and

RESOLVED—That the following be called for interview by the Committee on the 19th instant:—

Capt. D. Cameron Chisholm, M.C. (A.R.P. Officer, Walsall),
 Capt. J. C. Shepherd (A.R.P. Officer, Truro),
 C. le S. Metcalfe, Esq. (County Anti-Gas Instructor and Technical Adviser,
 Surrey County Council),
 Capt. D. R. G. Peal (A.R.P. Officer, County of Northumberland),

Capt. L. Travers Griffin (A.R.P. Officer, Gillingham),
 Capt. R. Matheson, M.C. (Divisional A.R.P. Officer, County and City of Gloucester),
 Capt. E. C. Grover (A.R.P. Organiser, No. 6 Area, County of Northumberland),
 Capt. L. C. Burcher (A.R.P. Officer, Leyton),
 Capt. E. C. Smith (A.R.P. Officer, Pontefract).

5.—WARDENS' ORGANISATION:

A letter dated the 24th March from the Home Office A.R.P. Department was submitted stating that the Lord Privy Seal in the exercise of the powers of the Secretary of State, had given careful consideration to the views expressed at the Conferences which had been held with representatives of the Local Authorities in the part of the London region outside the County of London, on the question of the organisation of the Wardens' service. The Lord Privy Seal recognises that divergent views are held by Local Authorities and by wardens as to the expediency of making a change on the existing organisation, but after a careful review of the position he has come to the conclusion that a central control of the practical training of the wardens in time of peace, and of their operations in time of war is desirable, and that this can best be effected on the lines set out in Sir Phillip Game's note of the 11th of February. (The general lines of the suggested re-organisation set out in Sir Phillip Game's note were reported to the Council on the 20th of March last—Minutes, pages 449 and 450). The Lord Privy Seal has accordingly decided that throughout the London Region while the recruitment and preliminary training of wardens will remain the function of the Local Authority, their practical training in time of peace and their operations in time of war shall be under the control of Sir Phillip Game acting through the Principal Warden.

The Hon. Arthur Howard, ex-Mayor of Westminster, and Chief Warden of the Westminster Air Raid Wardens' Service, has been appointed Principal Warden and he will be provided with an office and staff at New Scotland Yard and he, or his representative, will shortly get into touch with the various Authorities in the outer London area with a view to arranging the details and time of the transfer. The letter states that the change of control will not involve any change of financial responsibility and it is proposed that the Commissioner of Police of the Metropolis shall recover any expenses incurred in connection with the Organisation of the Wardens' service by way of the annual police precept on all Authorities in the Metropolitan Police District. It is not anticipated that any large expenditure will be incurred by the Commissioner of Police in this connection.

The letter further states that Sir John Anderson is confident that a decision having been taken, all concerned, whatever may have been their views on this question, will co-operate with Sir Phillip Game and the Principal Warden to bring the organisation of the Wardens' service as quickly as possible to a state of full preparedness on the new basis.

The Committee have noted the terms of the communication, and

RESOLVED—That a copy of the letter referred to be forwarded to each Divisional Warden with a request that the terms of the letter shall be notified to all Wardens in their respective Divisions.

6.—TRENCHES:

The Committee have had under consideration the question of proceeding with the digging and completion of trenches to provide accommodation up to 10 per cent. of the population of the Borough, and

RESOLVED TO RECOMMEND—That the Council press the Home Office for authority to proceed with the completion of the balance of the trenches required to provide accommodation for 10 per cent of the population of the Borough.

7.—CASUALTY ORGANISATION AND EMERGENCY AMBULANCE SCHEME:

Councillor Curton submitted a letter he had received from the Secretary of the Conference of Ratepayers Associations of Hendon on the above subject, and it was

RESOLVED—That the correspondence be referred to the Medical Officer of Health for a full report to be submitted to the next meeting of the Committee.

8.—OTHER BUSINESS:

The Committee gave consideration to a further matter, details of which will be reported to the Council in Committee.

Item 1—Chief Air Raid Warden—Nominations.

On consideration of the above item the Town Clerk reported the receipt of a letter from Lt. Commander R. F. Paget, R.N. (Retired), the Divisional Warden for Division III. (South) in the following terms:—

“Gentlemen,

Since writing you withdrawing my name from nomination as Chief Warden, it has become known that Mr. Bridge is a candidate to the Borough Council.

I have received numerous protests from the Wardens against a Councillor holding the post of Chief Warden. This principle has already been rejected by the Council at their Meeting on March 20th.

Had I known of Mr. Bridge's intention to stand for election to the Council, I would certainly not have withdrawn my name, or recommended the South Division to nominate him as Chief Warden, as I feel that the principle of the Warden's Organisation being controlled by Warden volunteers has been conceded and endorsed by the Council on various occasions and is essential to the well-being of A.R.P. in the Borough.

Yours faithfully,

(Signed) R. F. PAGET.”

MOTION moved by Councillor Arter, seconded by Councillor Curton:—

THAT Mr. T. Kirkland Bridge be appointed Chief Air Raid Warden.

AMENDMENT moved by Alderman Maughan, seconded by Alderman Flowers:—

THAT the item relating to the appointment of a Chief Air Raid Warden be referred back.

After discussion, the amendment was submitted and declared **carried**.

SUBSTANTIVE MOTION: Upon submission of the amendment as the Substantive Motion, it was declared **carried**.

227.—Accordingly **RESOLVED—That Item 1 of the Committee's report regarding the nomination of a Chief Air Raid Warden be referred back.**

Item 2—Co-option on Air Raid Precautions Committee.

AMENDMENT moved by Councillor Pinkney, seconded by Councillor Richardson:—

THAT the words “The Chief Warden” following “Air Raid Wardens' Organisation” in the Committee's recommendation be deleted.

After discussion, the amendment was submitted and declared **carried**.

SUBSTANTIVE MOTION: Upon submission of the amendment as the Substantive Motion, it was declared **carried**, whereupon a Division was demanded by Councillor Curton and two other Members and taken with the following result:—

For 15.	Against 13.	Abstained from Voting 3.	Absent when Division taken 4.
Alderman Copestake.	Alderman Reynolds.	The Mayor.	Alderman Clemens.
" Maughan.	" Rice.	The Deputy Mayor.	" Mour.
" Teare.	Councillor Arter.	Alderman Flowers.	Councillor Birshfield.
Councillor Bate.	" Curton.		" (Mrs.) Thomas.
" Collins.	" Gilpin.		
" Connell.	" Hicks.		
" Cox.	" Hignott.		
" Greville.	" Lightfoot.		
" Griffiths.	" Naar.		
" Pinkney.	" (Mrs.) Parvin.		
" Pryke.	" Shakespeare.		
" Pugh.	" Small.		
" Richardson.	" Windust.		
" Rodway.			
" Scott.			

228.—Accordingly **RESOLVED**—That the words "The Chief Warden" following "Air Raid Wardens' Organisation" in the Committee's recommendation be deleted.

Item 4—Appointment of Air Raid Precautions Officer.

On consideration of the above item the Town Clerk reported the receipt of twelve letters from certain Wardens in the South Division relative to the non-inclusion of Lt. Commander Paget, R.N. (Retired) in the list of candidates selected for interview by the Committee.

AMENDMENT moved by Alderman Maughan, seconded by Alderman Copestake:—

THAT the name of Lt. Commander R. F. Paget, R.N. (Retired) be added to the list of candidates selected for interview.

Discussion ensued.

Councillor Scott gave notice of a further amendment.

After further discussion, the amendment was submitted and declared **lost**.

FURTHER AMENDMENT moved by Councillor Scott, seconded by Councillor Greville:—

THAT it be an instruction to the Air Raid Precautions Committee to select three of the candidates called for interview for final selection by the Council at a Special Meeting to be held on Monday the 1st May.

After discussion, the amendment was submitted and declared **lost**.

The Mayor ruled out of order an amendment moved by Alderman Copestake, seconded by Councillor Scott, to the intent that a Special Meeting of the Council be convened for Wednesday next, the 19th instant, to interview the nine selected candidates.

ADOPTION OF REPORT: Moved by Councillor Arter, duly seconded, and

229.—**RESOLVED**—That, with the exception of item 8, the report of the Air Raid Precautions Committee, as amended, be approved and adopted.

ADJOURNMENT:

At 7.34 p.m., on the motion of the Mayor, the Council adjourned to 7.44 p.m. this day to be resumed in Committee to consider item 8 of the report of the Air Raid Precautions Committee.

Herbert G. Patten
Mayor.

Council in Committee

17th April, 1939.

PRESENT:

His Worship the Mayor (Councillor H. G. Potter, J.P., F.S.I.), *in the Chair.*

The Deputy Mayor (Alderman S. H. Egan, J.P.).

Aldermen:

J. J. Copestake, J.P.,
B. Flowers,

W. M. Maughan, J.P.,
A. J. Reynolds, J.P.,

F. C. Rice,
R. A. B. Teare, M.B.E.

Councillors:

E. Arter, M.C., M.I.A.E.,
F. J. Collins,
E. J. Cox,
A. W. Curton,
F. W. Gilpin,
A. W. Greville,
J. Griffiths,
W. A. Hicks,

G. H. Hignett,
P. Lightfoot,
A. A. Naar, M.B.E.,
(Mrs.) F. E. Parvin,
G. Pinkney,
G. J. Pryke, F.I.A.C.,
A.M.I.S.E.,
T. Pugh,

G. R. Richardson,
J. H. Rodway,
T. J. Scott,
W. H. N. Shakespeare,
M.C., A.F.C., J.P.,
H. P. Small,
C. F. Windust.

The Council in Committee gave consideration to the matter referred to under item 8 of the Report of the Air Raid Precautions Committee, full details of which are recorded in MS.

Moved by Councillor Arter, seconded by Councillor Curton, and

230.—RESOLVED—That item 8 of the report of the Air Raid Precautions Committee, *as amended*, be approved and adopted.

SPECIAL MEETING OF THE COUNCIL:

Moved by Councillor Arter, seconded by Councillor Curton, and

231.—RESOLVED—That a Special Meeting of the Council be convened for Monday next, the 24th April, 1939, at 6 p.m., to consider the report of the Meeting of the Air Raid Precautions Committee to be held on the 19th instant.

The meeting terminated at 8.28 p.m.

Mayor.

Minutes.

At a Special Meeting of the COUNCIL of the BOROUGH OF HENDON, held at the Town Hall, The Burroughs, Hendon, N.W. 4, on Monday, the 24th day of April, 1939, at 6 o'clock p.m.

PRESENT:

His Worship the Mayor (Councillor H. G. Potter, J.P., F.S.I.), in the Chair.

Aldermen:

W. R. Clemens, F.C.A.,
J. J. Copestake, J.P.,
B. Flowers,

W. M. Maughan, J.P.,
A. J. Reynolds, J.P.,

F. C. Rice,
R. A. B. Teare, M.B.E.

Councillors:

E. Arter, M.C., M.I.A.E.,
F. H. Bate,
H. Connell, J.P.,
A. W. Curton,
F. W. Cilpin,
A. W. Creville,
J. Griffiths,
W. A. Hicks,
G. H. Hignett,

L. Hirshfield,
P. Lightfoot,
A. A. Naar, M.B.E.,
(Mrs.) F. E. Parvin,
C. Pinkney,
C. J. Pryke, F.I.A.C.,
A.M.I.S.E.,
T. Pugh,

G. R. Richardson,
J. H. Rodway,
T. J. Scott,
W. H. N. Shakespeare,
M.C., A.F.C., J.P.,
H. P. Small,
C. F. Windust.

NOTICE OF MEETING:

The Town Clerk read the Notice convening the Meeting.

APOLOGIES FOR ABSENCE:

Apologies for absence were submitted on behalf of the Deputy Mayor (Alderman S. H. Egan, J.P.), Alderman B. J. Monro, Councillors (Mrs.) M. Thomas, F. J. Collins and E. J. Cox.

His Worship the Mayor reported that Alderman Egan (Deputy Mayor) was prevented from attending by reason of illness which had necessitated his admission to hospital, and that the absence of Alderman Monro and Councillor (Mrs.) Thomas was also occasioned by illness.

On the motion of the Mayor, it was

232.—RESOLVED—That the Town Clerk be instructed to convey to Aldermen Egan and Monro, and Councillor (Mrs.) Thomas the sincere sympathy of the Council and best wishes for a speedy recovery.

ACCELERATION OF CIVIL DEFENCE MEASURES:

The Mayor referred to the letter from the Under-Secretary of State, Home Office (A.R.P. Department)—see Item 6 of the Report of the Air Raid Precautions Committee—and asked the several Committees to have regard to the terms of the communication and in particular the direction as to priority being given to civil defence matters. In this connection he emphasised that all work other than that of an essentially urgent character should be postponed to enable the Chief Officers and their staffs to concentrate on work in relation to Air Raid Precautions.

REPORT OF THE AIR RAID PRECAUTIONS COMMITTEE:

Moved by Councillor Arter, seconded by Councillor Windust, and

233.—RESOLVED—That the following report of a meeting of the Air Raid Precautions Committee held on the 19th April, 1939, be received:—

19th April, 1939.

COMMITTEE:

*Councillor E. Arter, M.C., M.I.A.E. (Chairman).

Aldermen:

W. R. Clemens, F.C.A.,

*J. J. Copestake, J.P.

Councillors:

*F. H. Bate,
F. J. Collins,
*A. W. Curton,
*J. Griffiths,
*W. A. Hicks,

*C. H. Hignett,
L. Hirshfield,
*A. A. Naar, M.B.E.,
*C. Pinkney,
H. G. Potter, J.P., F.S.I.,
(Mayor),

*T. J. Scott,
*W. H. N. Shakespeare,
M.C., A.F.C., J.P.,
*C. F. Windust.

* denotes Member present.

Also present: Alderman B. Flowers, Councillors E. J. Cox, A. W. Greville and G. J. Pryke, F.I.A.C., A.M.I.S.E.

Apologies for absence were tendered on behalf of Councillors F. J. Collins and L. Hirshfield.

1.—MULTI-PURPOSE BUILDINGS—REPORT CENTRES—DEPOTS:

The Council on the 27th March (A.R.P.C., 8/3/39—1) approved the designs and estimates prepared by the Borough Surveyor for three multi-purpose buildings and authorised their submission to the County Council for approval. On the 13th April the Borough Surveyor, in company with the County A.R.P. Officer interviewed officials at the Home Office on the matter, when the need for the provision of a Report Centre in the basement of each building was stressed in order that each Division could operate as a self-contained unit; leaving the basement of the Hendon Technical Institute to be used as a Control Centre only. The plans for the Report Centres submitted at the interview had been revised by the Borough Surveyor at short notice to meet the latest Home Office requirements, and, additional provision had now been made for:—

Locker accommodation for clothing of stretcher bearers, bunk room, and increased messroom accommodation.

Sketch plans of the buildings were submitted to the Committee.

After a lengthy discussion the Home Office officials intimated approval in principle to the erection of three multi-purpose buildings equipped with Report Centres.

The Town Clerk reported the receipt of a letter addressed to the Middlesex County Council by the Home Office A.R.P. Department, a copy of which had been transmitted just prior to the meeting of the Committee, stating that the Home Office were prepared to agree in principle to the construction of the three multi-purpose buildings referred to above for use in peace time as:—

- (a) Equipment Stores,
- (b) Training and Social Centres.
- (c) Offices for Divisional Wardens.

and in war time:—

- (a) Report Centres,
- (b) Depôts for Reseue, First Aid and Repair Parties and Decontamination Squads.

The letter stated that the Lord Privy Seal would arrange a meeting later in the present week with representatives of the County Council to discuss certain modifications to the plans, and that when these had been agreed, he would require detailed priced specifications before approving any specific figure of expenditure on the buildings.

The estimated cost of the buildings is approximately £9,300 each, and it is understood that all three will be erected on Council property, but before proceeding further in the matter the Council are requested to take any necessary steps to see that the sites proposed are free from any restrictions on building. It is proposed to erect the multi-purpose buildings on the following sites:—

To serve the Southern No. III.				
Division	In Claremont Road on the Surplus (Sewage Disposal) Lands;
To serve the Central No. II.				
Division	On land at the rear of the Town Hall;
To serve the Northern No. I.				
Division	Lyndhurst Park.

The Committee have noted the progress made with this matter and have instructed the Borough Surveyor to submit a further report regarding the site of the multi-purpose building to serve the Northern No. I. Division after certain enquiries have been completed.

2.—STORAGE ACCOMMODATION:

The Town Clerk reported that he was proposing to arrange for three stores to be provided, one in each Division, and for the requisite equipment for the various personnel who will operate in each Division to be stored thereat, so that in the event of a state of emergency arising the distribution of equipment would be facilitated.

So far as the Northern No. 1 Division is concerned, it was reported that Councillor Curton had offered to place certain accommodation at the disposal of the Council and that such accommodation would be suitable, subject to the carrying out of any necessary internal fittings for the purpose which it is intended to serve.

The equipment for the Central No. II. Division will continue to be stored at Batty's Repository for the time being.

With regard to the Southern No. III. Division, considerable difficulty is at present being experienced, but efforts were still being made with a view to suitable accommodation being obtained. In this connection it was suggested that a portion of the Child's Hill Slipper Baths should be utilised for the purpose of storing equipment, and the Committee have instructed the Chief Officers to explore the possibilities of the proposal and to report thereon in conjunction with any further development in the matter.

RESOLVED TO RECOMMEND—That the report of the Town Clerk be approved and that the best thanks of the Council be accorded to Councillor Curton for his generous offer to place accommodation at the disposal of the Council.

3.—EQUIPMENT:

The Town Clerk reported that the following air raid precautions equipment had been supplied to the Council:—

	Large.	Medium.	Small.	Total.
Civilian Respirators	57329	85741	17761	160831

The majority of these Respirators have been assembled and distributed, and on the 17th instant there were still in stock approximately

2000	9000	2100	13100
------	------	------	-------

General Service Respirators	Large. 54	Normal. 1550	Small. 46	Total. 1650
Civilian Duty Respirators		Normal. 1918	Small. 568	Total. 2486
Light Anti-Gas Clothing	1300 suits.
Heavy Anti-Gas Clothing	89 suits.
Gum Boots	1112 pairs (men's). 143 pairs (women's).
Oilskin Hoods	162
Oilskin Gloves	1699 pairs
Steel Helmets	1090
Whistles (for Air Raid Wardens)	846
Torches	846
Danger Signs	36
Bleach Powder	36 cwts.
Stretchers	380 Steel. 14 Service pattern.

An intimation had been received that a consignment of eye shields would shortly be delivered and that supplies of whistles, torches, rattles, handbells, and Wardens' notebooks are now available. These supplies will be obtained as soon as possible.

The Committee have noted the above information with **satisfaction**.

4.—HENDON DIVISION, BRITISH MEDICAL ASSOCIATION—DEPUTATION:

The Council on the 27th February last (A.R.P.C., 8/2/39—1) on the recommendation of the Committee, after receiving a deputation from the Hendon Division of the British Medical Association, decided that the Chairmen of the Air Raid Precautions Committee and the Public Health and Medical Services Committee with the Medical Officer of Health be authorised to call into consultation representatives of the Association to consider matters of mutual interest as they arise and to report to this Committee thereon. The Town Clerk reported the receipt of a letter from the Secretary of the Hendon Branch of the Association referring to the Council's decision and stating that the Executive Committee of the Branch had formed the following conclusions:—

- (1) The position remains unsatisfactory in as much as the onus of consulting the Medical profession is unilaterally in the hands of the Air Raid Precautions Committee.
- (2) Many London authorities have Liaison Committees of the British Medical Association with whom consultations can easily be arranged on questions of air raid precautions.

The letter stated that the Executive Committee of the Local Branch of the British Medical Association would welcome evidence that the Council would consult the Committee freely as soon as occasion arises.

The Committee have received the observations of the Medical Officer of Health on the matter generally, and in particular with regard to the manning of first aid posts, which, being situated at existing hospitals already have a nucleus of Doctors which will be supplemented by local practitioners in consultation with the Local Branch of the British Medical Association.

RESOLVED TO RECOMMEND—That the Hendon Branch of the British Medical Association be informed that the Council will consult the Executive Committee of the Association freely as occasion arises.

5.—DIVISIONAL WARDENS' EXPENDITURE—MAPS, ETC.:

The Council on the 20th March (A.R.P.C., 8/3/39—2 (2), Minutes page 451) gave authority for the Divisional Wardens to be supplied with such maps as the County Council may approve for the purposes of their respective Divisions.

The Town Clerk reported the receipt of a letter from the County Air Raid Precautions Officer intimating approval to the provision of such maps and also payment of the actual expenditure incurred on typing assistance for the Divisional Wardens, heating and lighting of a room in the Divisional Wardens' residences, payment of postages, provision of stationery, and the provision of a telephone extension, and stating that such expenditure would rank for grant.

With regard to the question of car mileage allowance for Divisional and Head Wardens (A.R.P.C., 8/3/39—2 (2), Recommendation V, Minutes page 451), the County Council were unable to approve the granting of allowances in accordance with the Councils' scale, but intimated that the Home Office had indicated that only the actual cost of petrol and oil consumed should rank (apparently with no allowance for depreciation and overhead costs) and it was suggested that an allowance in the region of 1d. per mile should suffice.

The Committee have **duly noted** the terms of the County Air Raid Precautions Officer's communication.

6.—PRIORITY OF AIR RAID PRECAUTIONS AND DATES OF MEETINGS OF COMMITTEE:

In accordance with the Committee's directions, the Town Clerk submitted suggested dates for holding fortnightly meetings of the Committee, and in this connection reported the receipt of Home Office (A.R.P. Dept.) Circular No. 86/1939 on the subject of the acceleration of civil defence measures.

The letter stated that His Majesty's Government have had under review measures which can be taken to accelerate the process of organising National Defence in its various branches and that Sir John Anderson (Lord Privy Seal) has, in particular, directed his attention to the organisation and development of Civil Defence measures for which local authorities are primarily responsible. He fully recognises the pressure of work upon local authorities and their Officers which the organisation of these measures must entail, but he is confident that local authorities will appreciate the imperative need, in present circumstances, for taking all practical steps to ensure the greatest possible expedition. His Majesty's Government have, therefore, decided to request Local Authorities so to arrange their business that during the next three months priority is given to Civil Defence matters over other business before the authority, and to ensure that all responsible officers of the authority are instructed accordingly. The Government believe that the progress already made in Civil Defence is, in general, such that sustained effort for this period will mark a definite stage in the preparedness of the country to meet an emergency should it arise, and that this can be done without serious delay or interference in any essential social service for which the authority is responsible. The letter further points out that authorities have already been given general sanction from the Air Raid Precautions Department to incur expenditure on various items of Air Raid Precautions without the need for specific approval in each case and that authority had now been delegated to Regional Officers of the Department to authorise expenditure in a number of matters. Sir John Anderson regards it as unnecessary to indicate in detail to scheme-making authorities the various steps that might suitably be taken to ensure that progress over the area for which they are responsible is expedited, but he feels it desirable again to call the attention of the authorities to the need for making adequate provision in staff, both for the purpose of accelerating measures now in progress and for meeting the additional work which will arise in connection with the new Civil Defence Bill. In engaging any necessary additional staff, local authorities should have regard to the claims of the Defence Services on younger men, particularly

in the case of non-technical officers, and should bear in mind the age limits and classifications laid down in the schedule of reserved occupations or any modification thereof which may have been issued. The letter further states that the Lord Privy Seal indicated in his statement on the Second Reading of the Bill on the 4th April, if progress at a satisfactory rate under that measure is to be made it will be necessary for action to be taken before formal sanction of Parliament to the measure has been given, and the necessary preparations for this must be made beforehand. The letter contained a request that it should be brought forthwith to the notice of the Mayor in order that necessary steps may be taken at once to expedite action in this urgent matter.

The Town Clerk reported that he had been unable to bring the letter before the notice of the Mayor, but would inform His Worship by letter that the communication had been reported to the Committee.

The Committee considered the Town Clerk's suggestion regarding the proposed dates of further Meetings of the Committee, and it was

RESOLVED—That meetings of the Committee be held on Tuesday the 25th instant (following the meeting of the Education Committee), Tuesday the 2nd May at 6.30 p.m., and thereafter fortnightly at 6.30 p.m., until the end of July, and that in cases where the date of the meeting coincides with the Rating and Valuation Committee the latter Committee be convened for 6 p.m.

7.—HENDON AND DISTRICT TRADES COUNCIL—DEPUTATION:

The Committee received a deputation consisting of Messrs. J. Collyer, F. Price, F. Findley, and J. Thompson, representing the Hendon and District Trades Council.

Messrs. Findley and Collyer addressed the Committee and stressed the need for bomb-proof shelters for the protection of the civil population of Hendon, and urged the Council to prepare plans now for such shelters to be in readiness for proceeding with their construction if and when authority to proceed is given.

The Deputation urged the Committee to give a lead to the other authorities throughout the country by constructing one bomb-proof shelter in Hendon in a central position in order to illustrate to the inhabitants of Hendon that protection could be given from high explosive bombs by underground tunnels or shelters.

The deputation referred to the transfer of the Wardens' Service to the Commissioner of Police and viewed such transfer with suspicion and expressed the view that the protection of the people of Hendon should be as much as possible in the hands of the people themselves and that no force such as the Police or other State Body should have control over them whatsoever.

The Committee were urged to stimulate the employers of labour in the Borough to provide adequate protection for their employees and also to endeavour to persuade such employers to pay their employees for any time lost and also their expenses in undertaking the necessary aid raid precautions training.

The deputation also referred to the question of evacuation and urged the desirability of steps being taken with a view to Hendon being scheduled as an evacuation area.

The deputation also suggested that the training of Wardens should be improved and urged that less emphasis should be laid upon the anti-gas training as they were of opinion that gas was the weapon least likely to be used in aerial warfare.

The question of publicity was raised and the deputation contended that if an efficient publicity organiser were appointed the Council would readily obtain the full complement required. It was also urged that the agents of organised Trade Unions could help in the matter of recruiting and the co-option of a representative on the Committee was suggested as being essential.

The Committee were urged to initiate the co-ordination of industrial undertakings and suggested that a technical adviser should be appointed who should be paid jointly by the employers.

After the deputation had replied to questions put by members of the Committee they were thanked for their attendance. The Committee thereupon gave consideration to the points raised by the deputation and after very full deliberation

RESOLVED TO RECOMMEND—

- (1) **That the Town Clerk be instructed to circularise all employers of labour within the Borough employing fifty employees or over urging them to make provision for the protection of their employees and also to arrange for the training of their employees in air raid precautions.**
- (2) **That the attention of the various branches of the Chamber of Commerce within the Borough be drawn to the Home Office (A.R.P. Department) Handbook No. 6 "Air Raid Precautions in Factories and Business Premises."**

8.—APPOINTMENT OF AIR RAID PRECAUTIONS OFFICER:

The Committee interviewed the under-mentioned six candidates for the appointment of Air Raid Precautions Officer:—

Capt. D. Cameron Chisholm, M.C. (A.R.P. Officer, Walsall).

Capt. J. C. Shepherd (A.R.P. Officer, Truro).

C. le S. Metcalfe, Esq. (County Anti-Gas Instructor and Technical Adviser, Surrey County Council).

Capt. D. R. Peal (lately A.R.P. Officer, County of Northumberland).

Capt. L. Bureher (A.R.P. Officer, Leyton).

Capt. E. C. Smith (A.R.P. Officer, Pontefract Area Joint A.R.P. Committee).

The following candidates selected for interview were unable to attend:—

Capt. L. Travers Griffin (A.R.P. Officer, Gillingham).

Capt. R. Matheson, M.C. (Divisional A.R.P. Officer, County and City of Gloucester).

Capt. E. C. Grover (A.R.P. Organiser, No. 6 Area, County of Northumberland).

In connection with this appointment the Committee have duly noted a letter from Mr. A. S. Cavender, a Warden in the South No. III. Division, expressing regret that the Council had not deemed fit to include Lt. Commander Paget, the Divisional Warden for the South in the list of candidates selected for interview.

Each candidate for appointment was accorded a lengthy interview, and after very full consideration of their respective qualifications for the position, the Committee

RESOLVED TO RECOMMEND—**That, subject to satisfactory medical examination, Captain E. C. Smith, Air Raid Precautions Officer to the Pontefract Area Joint Air Raid Precautions Committee, be appointed full-time Air Raid Precautions Officer for the Borough of Hendon at a salary of £500 per annum, the engagement to be determinable by three months' notice on either side, in accordance with the terms and conditions prescribed in the advertisement.**

A further recommendation, together with certain instructions given to the Town Clerk in connection with the appointment of one of the selected candidates in the event of Captain Smith not taking up the appointment, is recorded in MS.

9.—APPOINTMENT OF CHIEF AIR RAID WARDEN:

The Committee have given further consideration to the question of the appointment of Chief Air Raid Warden which was referred back at the meeting of the Council on the 17th instant.

In this connection a petition received on the 19th instant and bearing 255 signatures addressed to the Chairman of the Committee was submitted in the following terms:—

"We, the undersigned, Air Raid Wardens, view with the greatest possible concern the action of the Hendon Borough Council held on Monday the 17th instant in referring back the appointment of Chief Air Raid Warden.

As a body of volunteers invited by the Council to use our democratic rights to nominate our Chief Air Raid Warden, we seriously deplore the delay in ratifying the result of the ballot."

A resolution in the following terms passed at a meeting of the Hendon Ratepayers' Association this evening was also submitted:—

"That the Hendon Borough Council having asked the Wardens for nominations for the post of Chief Air Raid Warden, this Association urges the Council to proceed with the appointment of such Officer in accordance with these nominations."

The Committee have further considered the question of the appointment of a Chief Air Raid Warden, and

RESOLVED TO RECOMMEND—That, subject to the approval of the Home Office, the Air Raid Precautions Officer when appointed be requested to undertake the duties of Chief Air Raid Warden.

10.—UNDERGROUND SHELTERS:

The Committee have **noted** a letter from the Southall Borough Council inviting the Council to support the following resolution passed by that authority on the subject of deep shelters:—

"That the Town Clerk be authorised to make representations to the County Council for an examination to be initiated into the question of the provision of deep underground shelters in Middlesex."

11.—AIR RAID WARDENS' ORGANISATION—RESIGNATION:

A letter was submitted from one of the Air Raid Wardens resigning from the Air Raid Wardens' Service for the reasons indicated in the letter and the Committee have instructed the Town Clerk as to the action to be taken thereon.

12.—PROGRESS REPORT OF BOROUGH ENGINEER:

The Borough Engineer submitted a report showing the progress made in the various sections of his Department engaged upon Air Raid Precautions work since the 8th March last as follows:—

(A). *Engineering Section.*
(i). *Lining of Trenches.*

The Engineering Section had completed the experimental length of trench at the Isolation Hospital. During the carrying out of the work the opportunity was taken of training eight of the Council's employees in the handling of this type of steel lining so that they could subsequently be split over other gangs working in the different parks.

Work is at present proceeding with the steel linings in Hendon and Child's Hill Parks. In addition the steel linings are being delivered to Watling Park and deliveries to Stonegrove Park will commence on Monday next. The whole of these linings are being supplied by the Steel Ceilings Ltd., Lewis Construction Department.

The Borough Engineer stated that up to the present Messrs. Guest Keen Baldwins Iron and Steel Co., had not been able to effect delivery of any linings. **Noted.**

(ii). *Completion of Trenches.*

The Borough Engineer reported that in accordance with the resolution passed by the Council on the 17th instant, to press for authority to proceed with the completion of the plans of the trenches to provide accommodation up to 10 per cent. of the population, viz., 17,250 persons, plans and estimates were being submitted to the Middlesex County Council. As previously reported, the cost of this work is estimated at £32,500. **Noted.**

(B). *Architectural Section.*

(i). *First Aid Posts.*

In addition to the preparation of the plans for the three multi-purpose buildings reported under Item 1 the Borough Engineer reported that pursuant to the arrangement arrived at with the Middlesex County Council that first aid posts are necessary at the Isolation Hospital and the Hendon Cottage Hospital, he had prepared a provisional sketch plan of the suggested buildings. He estimated the cost of each post in accordance with the plans submitted to the Committee, at £3,750.

RESOLVED TO RECOMMEND—That the plans and estimates prepared by the Borough Engineer be approved and forwarded to the Middlesex County Council for final approval.

(ii). *Sub-Report Centre—Mill Hill Swimming Pool.*

The Borough Engineer reported that the adaptation work necessary for the conversion of the dressing room at the women's swimming pool for a Sub-Report Centre under the Council's short term policy is now well in hand.

(C). *Administration Section.*

(i). *Census of Vehicles.*

This Section has been almost entirely occupied since the last meeting in preparing a Census of the available vehicles in the area. Much of the work carried out had been rendered abortive consequent upon a late decision by the Home Office that only vehicles which had been registered for two years could be available for local air raid precautions purposes. The requirements of the different sections and the progress reached in the scheduling of vehicles is as follows:—

Ambulance Services—78 vehicles are required.

The whole of these vehicles have now been obtained and vehicles for the ambulance service with an unladen weight of between one and two tons have been duly registered. All owners have been interviewed and there will be no difficulty in taking possession of such vehicles if and when the necessity arises. Details of the vehicles with registration numbers have been forwarded as required to the County Council.

General Services—45 vehicles.

These services include the light and heavy rescue parties, decontamination and repair squads for which purpose 45 lorries are required, the whole of which have been obtained and registered, and the registration numbers transmitted to the Traffic Commissioner in accordance with the regulations.

Auxiliary Fire Service—60 vehicles.

For this section 60 vehicles including 10 heavy type vehicles for water carrying purposes are required. Up to the present time 48 vehicles, including the 10 heavy type lorries have been obtained and registered, and the Borough Engineer anticipates that the balance will be obtained during the present week.

From the foregoing details it will be observed that out of a total of 183 vehicles, 171 have already been registered. The Borough Engineer points out that vehicles owned by contractors who are likely to be engaged on Government work have been omitted from the lists and due consideration has been given, in negotiating with the different traders concerned, to the problems of food supplies.

The Borough Engineer has informed the Committee that all the local traders and vehicle owners have co-operated with him in every possible way, and the Committee desire that this should be recorded in their report.

(ii). *Training of Ambulance Drivers.*

Arrangements have been made for commencing the actual training of the first 48 women volunteers as ambulance drivers and four classes of 12 each have been organised. The training in the first place will be on the roads at the Council Dépôt at Hendon Way.

(D). *Building Section.*

(i). *Advice to the Public.*

The Buildings Section have been engaged in giving advice to a large number of owners of buildings on the protection of buildings. In addition, 30 premises, including factories, schools, etc., have been visited and inspected and advice given as to the adaptation of portions of the buildings for shelter purposes. 16 applications have been submitted for air raid shelters in connection with private houses, and a number of these are under construction.

A large number of persons attend at the Building Inspector's Office each day for information and advice as to private shelters.

(ii). *Shelters for Persons caught in the Streets.*

Concurrently with the work carried out in the Building Section referred to above, quantities are being prepared of all the materials required to provide shelters for persons who may be caught in the streets during a raid. The Borough Surveyor reports that in the main, it will be necessary to use empty shops for shelter purposes as very few basements are available.

13.—PERSONNEL:

Decontamination, Rescue and Demolition Services.

The total number of volunteers required for the decontamination, rescue, demolition and repair services is 586, of which number 250 have already been enrolled. Of this number 100 are either trained or in course of training at the present time. The Borough Engineer reports that it will not be possible to accelerate the rate of training until additional C.A.G.S. Instructors are available.

In order to speed up the training the Committee have given instructions for the services of Mr. F. H. Day, C.A.G.S. (Special) of the Public Health Department to be utilised as far as possible, and that endeavours be made to obtain the services of a further C.A.G.S. Instructor mentioned by the Town Clerk.

14.—STORAGE ACCOMMODATION:

(i). *Generally.*

The Borough Engineer reported that the question of storage accommodation is giving rise to serious difficulties and that negotiations which he had been conducting for acquiring suitable accommodation for air raid precautions services generally in the southern area had proved abortive.

(ii).

Sandbags.

The question of the storage of sandbags is also one presenting considerable difficulty, and in this connection the Borough Engineer informed the Committee that he had submitted an application to the London Passenger Transport Board for consent to use a large arch under the Board's Railway in the vicinity of Montrose Playing Fields, and that if the application was successful the problem of the storage of sandbags would be solved.

The Committee have approved the steps taken by the Borough Engineer, and

RESOLVED TO RECOMMEND—That the Borough Engineer be authorised to conclude negotiations with the London Passenger Transport Board for the use of the Company's arch in question, subject to reasonable terms being agreed upon.

(iii).

Hendon Way Depot.

The Borough Engineer reported that he had prepared plans and specification for a building of a temporary construction to be erected at the Hendon Way Depot to take the place of the building destroyed by fire some months ago which was used for air raid precautions purposes.

The tenders were due to be received during the course of the next few days, and he asked for authority to give instructions for the work to be proceeded with, providing the lowest tender did not exceed the sum of money available.

RESOLVED TO RECOMMEND—That as a matter of urgency the Borough Engineer in consultation with the Chairman of the Committee be authorised to accept a suitable tender.

15.—EQUIPMENT FOR RESCUE PARTIES:

The Borough Engineer reported that pursuant to Home Office (A.R.P. Department) Circular No. 70/1939, he was preparing a schedule of the equipment which will be required for the light and heavy rescue parties. A certain amount of the requisite equipment is already available, but it will be necessary for a considerable amount to be supplied by the Government.

No information is yet to hand as to when further deliveries may be expected. **Noted.**

16.—FIRST AID POSTS:

Consequent upon the work which had been carried out since the transfer of control of the medical services to the Ministry of Health, the Medical Officer reported on the progress which had been made. A letter was submitted from the County Medical Officer of Health confirming the following as First Aid Posts:—

- (1) Health Centre, Hartley Avenue,
- (2) Redhill County Hospital,
- (3) Colindale (L.C.C.) Hospital,
- (4) Infectious Diseases Hospital, Hendon (Isolation Hospital),
- (5) Hendon "King Edward VII. Memorial" Cottage Hospital.
- (6) Manor House Hospital.

The letter stated that owing to the absence of accommodation for a first aid post at the Isolation Hospital and the Hendon Cottage Hospital, buildings will be required to be erected and that the Ministry of Health looked with favour on the provision of Nissen Huts for this purpose. Owing to the fact that it is not possible to have a first aid post within the Manor House Hospital, it is suggested that the house in Golders Hill Park be used as a first aid post. These premises belong to the London County Council and the County Medical Officer has communicated with that Authority enquiring whether

the house will be available and will notify the Medical Officer of their decision in due course. The preparation of plans and estimates for the first aid post at Redhill County Hospital will be undertaken by the staff of the Middlesex County Council, and it can be accepted that the plans and estimates of the work to be undertaken at Colindale (L.C.C.) Hospital and the house in Golders Hill Park will be done by the London County Council or the Middlesex County Council. The plans and estimates for the other first aid posts will be carried out by the Borough Surveyor's staff. The County Medical Officer requested that plans and estimates on completion should be submitted to the Middlesex County Council for transmission to, and approval by, the Ministry of Health before the actual works are put in hand. The plans for first aid posts are to include details of the work to be undertaken for the protection of buildings and personnel. With regard to the first aid posts to be provided at the Isolation Hospital and the Hendon Cottage Hospital, plans and estimates have already been prepared by the Borough Surveyor for transmission to the County Council. (See Item 6 (B) (i) of this Report.)

The Medical Officer of Health suggested that, with the consent of the County Council,

- (a) Plans be now prepared and materials accumulated for the adaptation and protection of the Health Centre at Hartley Avenue.
- (b) That the Borough Surveyor be instructed to prepare sketch preliminary plans for the conversion of the selected ward at the Colindale (L.C.C.) Hospital for transmission to the Engineering Department of the London County Council and that they be requested to proceed with the work as agreed between the London and Middlesex County Councils.

That it be left to the Borough Surveyor and himself to draw up and transmit such plans, without further reference to the Committee. No cost in connection with the work will fall upon the Council.

- (c) On the consent of the London County Council being received to the use of the premises in Golders Hill Park, similar procedure be followed as that set out in (b) above.
- (d) The plans be prepared forthwith and submitted to the Middlesex County Council for providing protection for the personnel at all first aid posts set out above.

RESOLVED TO RECOMMEND—That the proposals of the Medical Officer of Health be approved and adopted.

17.—AMBULANCE DEPOTS:

A letter was submitted from the County Ambulance Officer confirming the arrangements as to the siting of ambulance stations in the Borough consequent upon a joint inspection of the district on the 3rd instant. Seven stations have been agreed upon (detailed hereunder) each to accommodate ten ambulances, seven cars, leaving a reserve of eight ambulances.

- (1) Redhill County Hospital and yard at rear of Old Men's Quarters,
- (2) Mill Hill Swimming Pool, Daws Lane, to serve Health Centre in Hartley Avenue,
- (3) West Hendon Swimming Pool, Goldsmith Avenue, to serve Isolation Hospital,
- (4) Council Dépôt, Hendon Way, to serve Cottage Hospital,
- (5) Saunders Garage, 616, Finchley Road, to serve Manor House Hospital,
- (6) Hendon Secondary School, Golders Rise,
- (7) Apex Corner Garage, Apex Corner.

With regard to the ambulance station at the Apex Corner Garage, accommodation for the personnel would have to be found elsewhere and the letter suggests that possibly this could be obtained at the John Groom's Crippleage, which is in close proximity.

With regard to the eight ambulances in reserve, it is suggested that it may be found convenient to distribute these among the other stations, or alternatively, another station might be provided making the total of eight.

With regard to the stretcher fitments for ambulances, these have been dealt with in a circular issued by the Home Office, and the Council will shortly be advised as to whether such fitments would be provided by the Middlesex County Council, or whether this Council would be required to take steps to construct them locally.

RESOLVED TO RECOMMEND—

- (a) **That the Medical Officer of Health be authorised to approach the owners of Saunders Carage, 616, Finchley Road, and Apex Corner Carage, Apex Corner, for permission to use their premises as ambulance stations and that in the case of the John Groom's Crippleage, permission be sought to the use of such premises for accommodation for ambulance and first aid personnel.**
- (b) **That plans for the conversion of the ambulance depôts referred to above to include protection for personnel, be prepared forthwith and that as much of the adaptation work as possible be put in hand immediately the approval of the Middlesex County Council is received.**

18.—STRETCHER PARTY DEPOTS:

The Medical Officer of Health reported as to the siting of stretcher party depôts, and the Committee

RESOLVED TO RECOMMEND—That stretcher party depôts be based for the time being on ambulance depôts, that the approval of the County Council and the Home Office be obtained to this course, and that regard be had to this arrangement when planning storage and personnel accommodation at the ambulance depôts.

19.—ISOLATION HOSPITAL:

The Medical Officer of Health stressed the desirability of plans being prepared for the protection of the Isolation Hospital according to Emergency Medical Services Memorandum No. 1 and the accumulation of the necessary materials and that such plans be submitted forthwith to the Hospital Officer of the Ministry of Health for approval to the expenditure which the provision of such protection will involve. It is intended by the Ministry that the Isolation Hospital shall be up-graded to provide three complete surgical teams, and the Medical Officer suggested the desirability of the early submission of tenders and a revised application for loan sanction in respect of the new operating theatre approved by the Council, 30th January (P.H. & M.S.C., 9/1/39—26), to the Minister of Health with a request that the matter be given priority.

RESOLVED TO RECOMMEND—That the suggestions contained in the Medical Officer's report hereon be approved and adopted.

20.—MEDICAL PERSONNEL:

On the suggestion of the Medical Officer of Health, the Committee

RESOLVED TO RECOMMEND—That the Medical Officer of Health be authorised to ask the Local Emergency Committee of the British Medical Association to nominate three doctors and three deputies for the first aid posts at Mill Hill Health Centre and the Isolation Hospital respectively.

21.—STAFF:

The Medical Officer of Health asked for authority, in view of the large volume of work now devolving upon his Department, to engage the services of a part-time woman Doctor in a temporary capacity at a salary of £300 per annum, and also to appoint a temporary male clerk, preferably over 30 years of age at a salary of £200 per annum.

RESOLVED TO RECOMMEND—That, subject to the consent of the Middlesex County Council, a part-time woman Doctor be appointed on a temporary basis at a salary of £300 per annum and that a temporary male clerk be appointed at a salary of £200 per annum.

22.—COLLECTIVE TRAINING OF FIRST AIR PARTIES AND AMBULANCES:

On the report of the Medical Officer of Health, the Committee have authorised the use of a suitably-converted vehicle for the collective training of first aid parties in addition to the vehicles in use for the training of ambulance drivers.

23.—AUXILIARY PERSONNEL:

The Medical Officer of Health reported the numbers enrolled in the casualty organisation as follows:—

Men	-----	-----	-----	-----	-----	-----	-----	-----	235
Women	-----	-----	-----	-----	-----	-----	-----	-----	492
Women Ambulance Drivers	-----	-----	-----	-----	-----	-----	-----	-----	110
Women Hospital Supply Workers	-----	-----	-----	-----	-----	-----	-----	-----	70

The above figures do not include those likely to be available through the voluntary Associations, but with the inclusion of such figures, the Committee are informed, that there is still a need for approximately 400 men for first aid work and 450 women ambulance and car drivers.

The Committee have **noted with satisfaction** that the number of women first aid workers is up to war strength and that a reserve is now being built up.

24.—WOODSIDE PARK GARDEN SUBURB—FIRST AID POSTS:

The Medical Officer of Health reported that he had been in communication with the Medical Officer of Health of the Finchley Borough Council and that he had confirmed that that Authority had approved arrangements whereby the casualty organisation for the Woodside Park area would be covered by the first aid posts at St. Mary's School, Finchley War Memorial Hospital and the Mobile Unit attached to that Hospital. **Noted.**

25.—AUXILIARY ORGANISATION AND EMERGENCY AMBULANCE SCHEME:

The Committee at its last meeting referred to the Medical Officer of Health for report, correspondence received by Councillor Curton from Mr. R. H. Taylor, Secretary of the Conference of Ratepayers' Associations of Hendon. Such report has been considered and duly **noted** and the matters referred to are dealt with in various sections of this report.

26.—STAFF:

(i).

Borough Engineer's Department.

The Committee have considered the large volume of work which falls upon the Borough Engineer's Department in connection with Air Raid Precautions and have also had regard to the letter from the Home Office A.R.P. Department referred to earlier in this report in relation to the acceleration of civil defence measures, and they accordingly

RESOLVED TO RECOMMEND—That all work coming within the purview of the Borough Engineer excepting any of extreme importance be deferred to enable the Borough Engineer's Staff to concentrate on the work required to be carried out for Air Raid Precautions purposes and that the Borough Engineer be authorised to obtain such additional personnel as the circumstances may require.

(ii). *Borough Treasurer's Department.*

The Borough Treasurer submitted a report on proposals involving the allocation of duties arising on air raid precautions, and it was

RESOLVED TO RECOMMEND—

- (i) **That, subject to the concurrence of the Middlesex County Council, the proposal to allocate Mr. R. C. Sparkes to Air Raid Precautions Services be approved.**
- (ii) **That the Borough Treasurer be authorised to appoint a Junior for his Department through the Juvenile Employment Bureau.**

(iii). *Special Cases.*

The Committee received reports from the Town Clerk, Borough Surveyor, and Medical Officer of Health (A.R.P.C., 8/3/39—1 (3)) in relation to certain officers of their respective departments engaged on air raid precautions duties, and have directed that further reports, on the lines indicated be presented to the next meeting.

EMERGENCY FIRE BRIGADE ORGANISATION.

27.—RECRUITMENT OF AUXILIARY FIREMEN:

During the past month, 100 applications have been accepted for enrolment in the Auxiliary Fire Service, which is now up to the full complement of 550. Of the 150 others required as drivers, telephonists, messengers, etc., 76 have enrolled and the Chief Officer of the Fire Brigade hopes to have all vacancies filled within the next month.

28.—EQUIPMENT:

A further supply of two large and six light trailer pumps have been received from the Home Office, and an intimation has been given that six large and sixteen light trailer pumps will be delivered within the next few weeks.

29.—TEST MOBILISATION:

A test mobilisation and exercise was carried out on Saturday, the 25th March last when 220 auxiliary firemen reported for duty.

All the available fire fighting units were fully manned and equipped, and within twenty minutes of the assembly, the pumps and crews, towed by vans, had left the main Stations to patrol their respective sections.

Very useful information was gained from this exercise as to times, routes and the number of pumps required to cover these sections.

30.—PROMOTIONS:

The following temporary promotions have been made:—

Section Officers:—

Mr. H. Bevir,
Mr. W. Cannon,
Mr. D. A. Davis,
Mr. J. J. Ellis,

Mr. F. Hillier,
Mr. S. Laughlin,
Mr. H. W. Peacock,
Mr. R. Potter.

Sub-Officers:—

Mr. R. H. Biggs,
 Mr. C. H. Davis,
 Mr. E. S. Davis,
 Mr. N. A. Everett,
 Mr. A. Foskett,
 Mr. W. Garvan,
 Mr. A. G. Giles,
 Mr. H. B. Goss,
 Mr. H. Harris,
 Mr. R. Jordan,
 Mr. H. S. Jupp,

Mr. L. M. Jeremy,
 Mr. E. Lambourne,
 Mr. H. S. Lipkin,
 Mr. A. H. Livsey,
 Mr. H. F. Mertens,
 Mr. D. Naar,
 Mr. D. G. Rye,
 Mr. S. W. Sexton,
 Mr. W. J. Stewart,
 Mr. H. R. Tyler.

These Officers were asked to send in reports of their respective sections on the test mobilisation and the Chief Officer of the Fire Brigade states that he was much impressed by the informative and interesting reports which were handed in.

31.—CLOTHING AND ACCOUTREMENTS:

On the report of the Chief Officer of the Fire Brigade, it was

RESOLVED TO RECOMMEND—That authority be given to purchase the following articles of clothing and accoutrements at an estimated cost of £1,172 1s. 0d.:—

	£	s.	d.
260 Double-breasted Tunics at 38/6d. each	500	10	0
260 pairs Trousers at 11/- per pair	143	0	0
260 Caps complete with badges at 4/- each	52	0	0
260 Overalls at 9/- each	117	0	0
206 Axes, Belts and Pouches at 13/6d. per set	139	1	0
300 Rubber Wellington Boots at 9/- per pair	135	0	0
40 Overalls for Women Telephonists at 11/6d. each	23	0	0
20 Coats for Women Drivers at 47/6d. each	47	10	0
20 Caps and Badges for Women Drivers at 6/- each	6	0	0
20 pairs Rubber Boots for Women Drivers at 9/- per pair	9	0	0
	£1,172	1	0

32.—HIRE OF VEHICLES:

RESOLVED TO RECOMMEND—That authority be given for the payment of £5 5s. 0d. in respect of the hire of fourteen motor vehicles (7/6d. per vehicle) which were used for the test mobilisation on 25th March last.

Item 8—Appointment of Air Raid Precautions Officer.

On consideration of the above item, the Town Clerk read a letter from Mr. Louis Levy stating that at a general meeting of the Air Raid Wardens of the South Division held on Monday last at Child's Way School, the following resolution was put to the meeting and carried by 256 votes to 9:—

“This Meeting of the Wardens of the South Division understands that its Divisional Warden has applied for the position of Air Raid Precautions Officer for the Borough of Hendon, and in view of his obvious qualifications this Meeting would welcome his appointment.” **Noted.**

A letter was also submitted from Captain E. C. Smith, recommended for appointment to the post of Air Raid Precautions Officer, stating that he will be able to take up his duties within 14 days of being notified of the confirmation of his appointment by the Council. **Noted.**

Item 9—Appointment of Chief Air Raid Warden.

The Town Clerk read the following letter which had been received in relation to the appointment of a Chief Air Raid Warden:—

April 23rd, 1939.

"Sir,

We, as Divisional Wardens of the North and Central Divisions, feel bound to submit the following to correct a misunderstanding which may have exercised considerable influence on the members of the Hendon Borough Council in considering the appointment of a Chief Warden.

At the last meeting of the Hendon Borough Council on April 17th, 1939, a letter was read from Lt.-Commander Paget in which the following statement was read:—

"Had I known of Mr. Bridge's intention to stand for election to the Council I would have certainly not withdrawn my nomination or recommended the South Division to nominate Mr. Bridge as Chief Warden."

In view of the wide publicity afforded this letter, last Monday, we respectfully request that the following facts be placed before the Council on the earliest possible occasion:—

A meeting of the three Divisional Wardens was held on Thursday, March 30th last, at which were also present Mr. Louis Levy, Deputy Divisional Warden of the South Division and Mr. M. Barney, Group Warden of the South Division. At this meeting Mr. Kirkland Bridge clearly stated his intention of standing for the Hendon Borough Council and invited the views of those present. Commander Paget expressed his approval, as did his officers, who further offered their personal assistance in the event of an election taking place.

It was only after this meeting, and in full knowledge that Mr. T. K. Bridge was standing for the Hendon Borough Council, that Commander Paget informed us that he intended to withdraw his nomination as Chief Warden and would recommend the South Division to nominate Mr. Bridge for that office.

As it is clearly laid down in Home Office Memorandum No. 4 that the Chief Warden shall be a volunteer we feel confident that the Council, now that their doubt regarding the ballot is removed, will wish, without further delay, to ratify the nomination made by the Wardens.

Yours faithfully,

(Signed) A. G. PETRIE, North Division.

(Signed) T. KIRKLAND BRIDGE, Central Division.

A copy of this letter has been forwarded to Councillor Erland Arter, M.C., Chairman of the A.R.P. Committee."

The Town Clerk further reported that pursuant to the terms of the Committee's recommendation, he had made enquiries of the Home Office and had been informed that the Department will not agree to the Air Raid Precautions Officer acting as Chief Air Raid Warden, and that the Department require that a volunteer should be appointed to the position.

AMENDMENT moved by Alderman Copestake, seconded by Alderman Flowers:—

THAT in view of the decision of the Home Office the item relating to the appointment of Chief Air Raid Warden be referred back for further consideration.

Councillor Curton gave notice of a further amendment.

The amendment, on submission, was declared **carried.**

AMENDMENT moved by Councillor Curton, seconded by Councillor Windust:—
THAT the Council confirm the nomination of Mr. T. K. Bridge as Chief Air Raid
Warden.

The amendment, on submission, was declared **lost**.

SUBSTANTIVE MOTION: Upon submission of the amendment for the refer-
ence back of the item, it was declared **carried**.

234.—Accordingly **RESOLVED**—That **item 9 of the report of the Air Raid Precautions
Committee be referred back for further consideration.**

Item 10—Underground Shelters.

AMENDMENT moved by Councillor Pinkney, seconded by Councillor Connell:—

THAT the above item be referred back for further consideration.

After discussion the amendment was submitted and declared **lost**, whereupon a divi-
sion was demanded by Councillor Connell and two other Members and taken with
the following result:—

For 11.	Against 18.	Abstained from Voting 1.	Absent when Division taken 5.
Alderman Flowers.	Alderman Clemens.	The Mayor.	The Deputy Mayor.
" Maughan.	" Copestake.		Alderman Monro.
" Rice.	" Reynolds.		Councillor Collins.
" Teare.	Councillor Arter.		" Cox.
Councillor Connell.	" Bate.		" (Mrs.) Thomas.
" Griffiths.	" Curton.		
" Hirshfield.	" Gilpin.		
" Pinkney.	" Greville.		
" Pugh.	" Hicks.		
" Richardson.	" Hignett.		
" Rodway.	" Lightfoot.		
	" Naur.		
	" (Mrs.) Parvin.		
	" Pryke.		
	" Scott.		
	" Shakespeare.		
	" Small.		
	" Windust.		

ADOPTION OF REPORT: On the motion for the adoption of the Report,
the Chairman of the Committee thanked the Mayor for attending to preside at the
Meeting of the Council at considerable inconvenience to himself, and also thanked
the Members of the Air Raid Precautions Committee for their contribution to the
deliberations of the Committee extending over a period of 6½ hours. He also ex-
pressed his thanks to the Chief Officers and members of the Staff in attendance
at the Committee.

Moved by Councillor Arter, seconded by Councillor (Mrs.) Parvin, and

235.—**RESOLVED**—That the report of the Committee, as amended, be approved and
adopted.

The meeting terminated at 7.28 p.m.

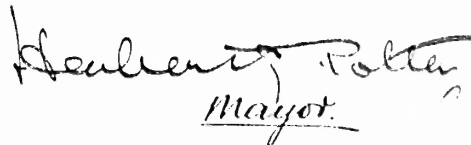
 Mayor.

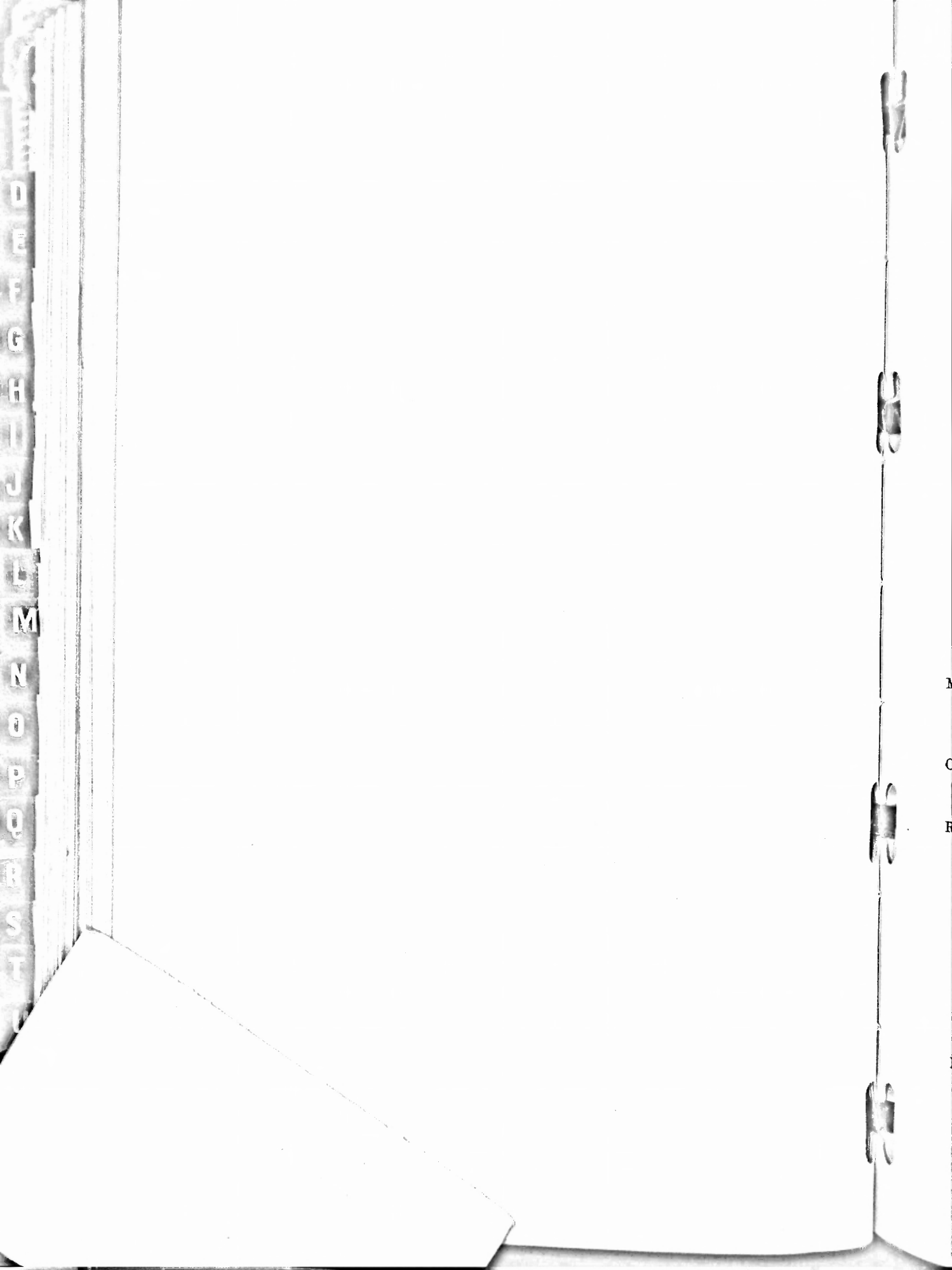

A
B
C
D
E
F
G
H
I
J
K
L
M
N
O
P
Q
R
S
T
U
V
W
X
Y
Z

M
C
R

Reports of Committees.

Report (No. 1) of the Education Committee.

25th April, 1939.

COMMITTEE:

*Alderman J. J. Copestake, J.P. (*Chairman*).

Aldermen:

S. H. Egan, J.P.,
*B. Flowers,

*W. M. Maughan, J.P.,

B. J. Monro.

Councillors:

*E. Arter, M.C., M.I.A.E.,
*H. Connell, J.P.,
*A. W. Curton,
*G. H. Hignett,
*P. Lightfoot,

*A. A. Naar, M.B.E.,
*(Mrs.) F. E. Parvin,
*T. Pugh,
*G. R. Richardson,
*T. J. Scott,

*W. H. N. Shakespeare,
M.C., A.F.C., J.P.,
*H. P. Small,
(Mrs.) M. Thomas.

Co-opted:

*Mrs. S. J. Bannister,
L.L.A.,
*The Rev. N. R. Boyd,
M.A.,

*Major N. G. Brett
James, M.A.,
B.Litt., F.S.A.,

*The Rev. P. G. Howell,
*The Rev. I. Livingstone.

* denotes Member present.

Apologies for absence were submitted on behalf of Aldermen Egan and Monro.

MINUTES:

The Minutes of the Meetings held on the 14th, 20th and 21st March, 1939, were read, confirmed and signed.

CORRESPONDENCE:

The various letters had been referred to the respective Sub-Committees.

REPORT OF PUBLIC HEALTH AND MEDICAL SERVICES COMMITTEE:

RESOLVED—

THAT the following extract from the Report of the above Committee, dated 17th April, 1939, be received:—

REPORT OF SCHOOL MEDICAL OFFICER.

I. STATISTICAL INFORMATION:

Statistics for the six weeks ended on the 8th April were submitted and are summarised in the Appendix to the report of the Finance and General Purposes Committee.

II. DEFECTIVE CHILDREN:

On the report of the School Medical Officer, it was

RESOLVED TO RECOMMEND—That in the undermentioned cases action be taken as follows:—

Case.	Defect.	Recommendation.
D.C., Burnt Oak	Marked debility	4 weeks' convalescence.
J.P., Burnt Oak	General debility	4 weeks' convalescence at a Roman Catholic Home.
E.K., Burnt Oak	Spina Bifida, etc.	Admission to a Day School for Physically Defective Children.
M.B., Burnt Oak	Spina Bifida and Epilepsy	Admission to a Residential School for Physically Defective Children.
D.W., N.W. 2	General debility	One month's convalescence.
T.H.J., N.W. 2	Educable Mental Defective	Admission, subject to approval of Board of Education, to Besford Court Catholic Mental Welfare Hospital, Worcester.

III. DENTAL ATTENDANT:

The Committee interviewed selected applicants to fill the vacancy created by the resignation of Miss Hidson. (P.H. & M.S.C., 6/3/39—8).

RESOLVED TO RECOMMEND—That subject to the receipt of a satisfactory medical report Miss Gladys Melsom of Holland Park be appointed on the permanent staff to the post of Dental Attendant at a commencing salary of £130 per annum, rising subject to satisfactory service by annual increments of £10 to £160, the engagement to be determinable by one month's notice on either side.

[Having considered the matter in its financial bearing, the Finance and General Purposes Committee concur in the proposal.]

IV. DENTAL TREATMENT:

A report was received from the School Medical Officer with regard to cases where parents persistently refuse to accept any form of dental treatment for their children except in extreme necessity. The attendance of these children at the Health Centre means that the preventive treatment in routine cases is delayed, and the parents referred to invariably define precisely the treatment to be carried out and refuse to attend again except in similar circumstances. Other authorities have apparently experienced these difficulties and have deemed it necessary to take appropriate action.

RESOLVED TO RECOMMEND—

- (1) **That when parents refuse complete treatment as a result of routine inspection, the child shall not be treated following such refusal as a "Special" until the next routine dental inspection, when the offer of complete dental treatment will be renewed.**
- (2) **That parents who persistently refuse treatment for their children for three consecutive years shall be eliminated from the scheme.**

V. TREATMENT OF SPEECH DEFECTS:

A communication was submitted from the Middlesex Education Committee agreeing to the proposed payment of 2/- per attendance to be made by the Committee for the treatment of speech defects of approved Secondary School pupils (E.C., 22/11/38—Page 64—Item III.). The Middlesex Education Committee suggest that the arrangement should date as from 1st April, 1939. **Approved.**

VI. MILK IN SCHOOLS SCHEME:

Reference was made to a communication addressed to Voluntary Associations in connection with the proposal for the supply of milk to school children during the mid-summer holidays. (E.C., 14/3/39—Page 474—Item 2).

RESOLVED TO RECOMMEND—That the Education Committee be asked to reconsider the matter in relation to the question of organisation.

VII. REQUISITIONS:

Requisitions amounting to the sum of £48 8s. 7d. were submitted and approved.

Moved by Councillor Scott, seconded by Mrs. Bannister, and **RESOLVED—**

THAT the foregoing extract from the Report of the Public Health and Medical Services Committee be approved and adopted.

SCHOOL MANAGEMENT SUB-COMMITTEE:

RESOLVED—

THAT the following Report be received:—

28th March, 1939.

SUB-COMMITTEE:

***Alderman B. Flowers** (*Chairman*).

Aldermen: ***J. J. Copestake, J.P., *W. M. Maughan, J.P.,**

Councillors: **E. Arter, M.C., M.I.A.E., *T. Pugh, *T. J. Scott,**
***P. Lightfoot, *C. R. Richardson, (Mrs.) M. Thomas,**
A. A. Naar, M.B.E.,

Co-opted: ***Major N. G. Brett *The Rev. P. C. Howell.**
James, M.A.,
B.Litt, F.S.A.,

** denotes Member present.*

1.—AMALGAMATION OF INFANT AND JUNIOR DEPARTMENTS:

The Sub-Committee received a deputation from the Hendon Teachers' Association concerning the policy of amalgamating Infant and Junior Departments.

RESOLVED TO RECOMMEND—

THAT the Director of Education be instructed to submit a report on the matter for consideration by this Sub-Committee in due course.

2.—COMMUNITY CENTRES:

(a) CLITTERHOUSE ESTATE:

In pursuance of the instructions of this Sub-Committee, the Borough Surveyor submitted a report with regard to the availability of a site for a Community Centre to serve the needs of the Clitterhouse Estate, the Midland Brent Cottages and the houses immediately adjoining on the Golders Green Estate.

RESOLVED TO RECOMMEND—

THAT the Town Clerk be instructed to ask the Ministry of Health whether approval would be granted to the erection of a Community Centre on a plot of land forming part of the Clitterhouse Open Space.

(b) WATLING CENTRE:

A letter was submitted from the Middlesex Local Education Authority asking whether the Borough Council would be prepared to make a contribution towards the capital expenditure likely to be involved in connection with the proposed extension of the Watling Centre, the plans of which provide for the erection of a Hall, a Gymnasium and additional rooms for adult and youth activities, and the scheme being so arranged that a portion of the site is reserved to allow for the erection of a Branch Library of the Borough Council. The cost of the proposed extension is estimated at £19,000.

RESOLVED TO RECOMMEND—

THAT consideration of this matter be deferred and that, in the meantime, fuller details and plans be obtained from the Middlesex Education Committee for submission to this Sub-Committee.

3.—FRITH MANOR COUNCIL SCHOOL:

A letter was submitted from the Board of Education stating that this school has been recognised as a Public Elementary School providing accommodation for not more than 400 junior mixed and infant scholars as from 23rd January, 1939. The Board note that a male Head Teacher has been appointed, and they raise no objection to this arrangement on condition that a responsible woman assistant teacher is given general charge of the Infants under the supervision of the Head Teacher. **Noted.**

4.—ST. AGNES' R.C. SCHOOL:

It was reported that a letter had been received from the Board of Education stating that, subject to the drainage and drainage disposal work being carried out to the requirements of the Local Sanitary Authority and on the understanding that the school will be re-organised for Junior Mixed and Infant children not later than 31st August, 1940, the Board approve the work shown on the plans forwarded to them for the enlargement of the school so as to provide accommodation for 316 juniors and infants. **Noted.**

5.—AIR RAID PRECAUTIONS:

(a) LETTER FROM THE MIDDLESEX LOCAL EDUCATION AUTHORITY:

The Director of Education reported the receipt of a copy of a circular letter addressed to its schools by the Middlesex Local Education Authority which had been forwarded for the information of the Hendon Local Education Authority. **Noted.**

(b) HENDON HEAD TEACHERS' ASSOCIATION:

The following resolutions from the Hendon Head Teachers' Association were submitted:—

“THAT this meeting of Head Teachers desires information regarding the safety of school children in the event of a National Emergency and asks for representation on the Local A.R.P. Committee.”

“THAT this meeting of Head Teachers asks for an adequate supply of First Aid material to be provided for each school immediately for use in the event of a National Emergency.”

RESOLVED TO RECOMMEND—

THAT the question of representation on the Air Raid Precautions Committee be referred to the Borough Council and that the Director of Education be instructed to reply to the other points raised on the lines indicated.

6.—COLINDALE SCHOOL:

A letter was submitted from the Rev. E. S. Butler stating that the Parochial Church Council much appreciated the care which had been taken of the Church Hall throughout its occupation for school purposes during the past two years. The Council add that the manner in which the children behaved reflected great credit on the whole school.

7.—REQUISITIONS:

Noted with satisfaction.

Requisition Sheets Nos. 291/3 amounting to £610 19s. 2d. were submitted and **approved.**

Moved by Alderman Flowers, seconded by Councillor Scott, and **RESOLVED—**

THAT the Report of the School Management Sub-Committee be approved and adopted.

WORKS SUB-COMMITTEE:

RESOLVED—

THAT the following Report be received:—

28th March, 1939.

SUB-COMMITTEE:

*Councillor W. H. N. Shakespeare, M.C., A.F.C., J.P. (*Chairman*).

Aldermen: *S. H. Egan, J.P.

*B. J. Monro.

Councillors: *H. Connell, J.P.,

*G. H. Hignett,

*A. W. Curton,

*(Mrs.) F. E. Parvin,

*H. P. Small.

Co-opted: *(Mrs.) S. J. Bannister,
L.L.A.,

The Rev. N. R. Boyd,
M.A.,

The Rev. I. Livingstone.

* denotes Member present.

An apology for absence was submitted on behalf of the Rev. I. Livingstone.

1.—DOLE STREET JUNIOR AND INFANT SCHOOL:

(a) PROGRESS:

Progress on this contract has been well maintained. The hardwood block and strip floors are in process of being laid, and inside the school the work remaining to be done consists largely of minor matters. The Caretaker's bungalow is practically completed and will be ready for occupation on 1st April. **Noted.**

(b) FIRE EXTINGUISHERS, ETC.:

RESOLVED TO RECOMMEND—

THAT the joint action of Alderman Copstake and Councillor Shakespeare in authorising the Architect to accept the quotation of The Nuswift Engineering Co. Ltd., amounting to £23 8s. 0d. for fire extinguishers, etc., be confirmed.

2.—FRITH MANOR JUNIOR AND INFANT SCHOOL:

(a) PROGRESS:

With the exception of a few small items the whole of the works comprised in this contract, including the surfacing of the Boys' and Girls' playgrounds, are now completed. **Noted.**

(b) **PLAYING FIELD:**

The Surveyor submitted a plan showing a proposed alternative scheme for providing a playing field on 2½ acres of the adjoining land which was acquired for Open Space purposes. A certain amount of drainage and filling will be necessary at the south-western corner.

RESOLVED TO RECOMMEND—

THAT, subject to the necessary sanctions being obtained, the aforementioned scheme be approved at an estimated cost of £450 to be met from Revenue, and that a re-allocation of the land as between Education and Public Open Space be made as follows:—

2.73 acres of the Open Space to be appropriated for Education purposes and 2.5 acres of the School Site to be appropriated for the Public Open Space.

[Having considered the matter in its financial bearing, the Finance and General Purposes Committee concur in the proposal.]

(c) **ENTRANCE STEPS:**

The Surveyor reported on a letter received from the Woodside Park Garden Suburb Ratepayers' Association regarding the construction of the entrance steps to the School.

RESOLVED TO RECOMMEND—

THAT a report be obtained from the Head Master on the lines mentioned for consideration at the next meeting.

3.—**FIRE EXTINGUISHERS IN SCHOOLS:**

A letter was considered from the Hendon Ratepayers' Association regarding the Committee's recent decision to instal one-gallon fire extinguishers in certain schools.

RESOLVED TO RECOMMEND—

THAT a reply be forwarded to the Association on the lines mentioned.

4.—**BURROUGHS AND CRESSINGHAM ROAD PLAYING FIELDS:**

RESOLVED TO RECOMMEND—

THAT the Borough Surveyor be instructed to carry out the improvements specified to the high and long jump pits at the above-named playing fields at an estimated cost of £2.

5.—**MEADS INFANTS' SCHOOL—ELECTRIC LIGHT FITTINGS:**

It was reported that the Borough Surveyor had made an inspection of the electric light fittings at this school when it was found that certain repairs and improvements were necessary.

RESOLVED TO RECOMMEND—

THAT the Borough Surveyor be instructed to carry out the necessary work at an estimated cost of £85.

[Having considered the matter in its financial bearing, the Finance and General Purposes Committee concur in the proposal.]

6.—**REPAIRS TO SCHOOLS:**

The Borough Surveyor reported that he had made a careful investigation into the question of repairs to school buildings and had discussed the matter with the Director of Education.

Owing to the growth of the number of schools under the Committee's jurisdiction and the consequent additional number of items of repair required, it would appear that some modification of the existing system is desirable.

The Borough Surveyor submitted a revised scheme for dealing with this matter.

RESOLVED TO RECOMMEND—

THAT the scheme as outlined in the Borough Surveyor's report be approved and adopted.

7.—ST. AGNES' R.C. SCHOOL—ENLARGEMENTS:

A communication was submitted from the Board of Education approving the work shown on the plans for the enlargement of this school, subject to the observations mentioned.

It was reported that a copy of this letter and the plans in question had been forwarded to the Managers for attention. **Noted.**

8.—REQUISITIONS:

Requisition Sheet No. 271, amounting to £397 5s. 7d., was submitted and **approved.**

Moved by Councillor Shakespeare, seconded by Councillor Hignett, and

RESOLVED—

THAT the Report of the Works Sub-Committee be approved and adopted.

STAFFS AND SALARIES SUB-COMMITTEE:

RESOLVED—

THAT the following Report be received:—

28th March, 1939.

SUB-COMMITTEE:

Councillor E. Arter, M.C., M.I.A.E. (*Chairman*).

Aldermen: *J. J. Copestake, J.P., *B. Flowers, *W. M. Maughan, J.P.
(*Presiding*),

Councillors: *P. Lightfoot, *T. Pugh, *T. J. Scott,
A. A. Naar, M.B.E., *C. R. Richardson, (Mrs.) M. Thomas.

Co-opted: *Major N. G. Brett
James, M.A.,
B.Litt, F.S.A.,

* denotes Member present.

1.—SCHOOL CARETAKERS:

The Sub-Committee received a deputation from the Hendon School Caretakers' and Cleaners' Branch of the National Union of General & Municipal Workers urging a revision of the basis on which "Cleaner" hours are assessed, particularly in relation to the duties of the Caretakers' wives.

RESOLVED TO RECOMMEND—

THAT this matter be referred to a Special Sub-Committee comprising Aldermen J. J. Copestake and W. M. Maughan, and Councillors E. Arter, P. Lightfoot and C. R. Richardson for consideration and report.

2.—THE MEADS JUNIOR MIXED SCHOOL—HEAD TEACHER:

The Sub-Committee considered a summary of 27 applications for the post of Head Teacher of this school, and RESOLVED—

THAT the undermentioned candidates be invited to attend for interview by the Education Committee (In Committee) on the 25th April, 1939:—

Bryant, William H.
 Gillett, Aileen V. P.
 Jacques, Harold
 Morley, L.L.A., Frances
 Rippin, Ena M.
 Williamson, Joseph

3.—SCHOOL CARETAKERS—ANNUAL INCREMENTS:

RESOLVED TO RECOMMEND—

THAT annual increments according to scale be granted to Mr. T. Keywood, Bell Lane Council School, and Mr. W. S. Jones, Algernon Road Council School, as from 19th May and 1st June, 1939, respectively.

4.—ESTABLISHMENT OF TEACHERS, 1939/40:

RESOLVED TO RECOMMEND—

THAT application be made to the Board of Education for approval to an estimated establishment of 430 teachers for the financial year 1939/40.

5.—RESIGNATIONS:

RESOLVED TO RECOMMEND—

THAT the undermentioned resignations be accepted:—

Teacher.	School.	Date of Leaving.
Harris, Dorothy M.	All Saints' C.E.	30/4/39
Middleton, B.Sc., Jack F.	Edgware Senior Mixed	23/4/39
Mockridge, Mary E.	Wessex Gardens Infant.....	30/4/39

In connection with the above, it was further RESOLVED—

THAT Miss Harris be granted special leave of absence, without salary, from 18th to 30th April, 1939.

6.—ABSENCES OF TEACHERS, ETC.:

(a) GENERAL LIST:

A Statement with regard to the absences of 97 teachers, etc., was submitted and noted.

(b) SPECIAL CASE:

RESOLVED TO RECOMMEND—

THAT, having regard to the special circumstances connected therewith, Mrs. C. Harrop, Barnfield Junior Mixed School, be paid full salary in respect of her absence which began on 6th March, 1939, and that such period of absence be ignored when determining subsequent sick leave allowances due to her under the Committee's regulations.

Moved by Councillor Arter, seconded by Councillor Lightfoot, and RESOLVED—

THAT the Report of the Staffs and Salaries Sub-Committee be approved and adopted.

SCHOOL ATTENDANCE SUB-COMMITTEE:

RESOLVED—

THAT the following Report be received:—

28th March, 1939.

SUB-COMMITTEE:

*Councillor C. H. Hignott (Chairman).

Aldermen: *S. H. Egan, J.P. *B. J. Monro.
Councillors: H. Connell, J.P., *(Mrs.) F. E. Parvin, *W. H. N. Shakespeare,
 *A. W. Curton, *H. P. Small. M.C., A.F.C., J.P.
Co-opted: *(Mrs.) S. J. Bannister, The Rev. N. R. Boyd, The Rev. I. Livingstone,
 L.L.A., M.A.,

* denotes Member present.

An apology for absence was submitted on behalf of the Rev. I. Livingstone.

1.—JUVENILE COURT PROCEEDINGS:

Particulars of cases dealt with during the period 23rd February, 1939, to 23rd March, 1939, were submitted as follows:—

Charges and Summonses: Young People 11, Children 6, Total 17.

Offence.	Sex and age of Child or Young Person.	Action taken.
At Wealdstone:—		
Larceny (Servant)	Boy, 12½ years	To Approved School.
Larceny	Boy, 10½ years	Dismissed P.O. Act.
Larceny	Boy, 11½ years	Dismissed P.O. Act.
Failing to maintain brakes.....	Boy, 16¼ years	Fined 10/-.
Holding on to lorry	Boy, 15¼ years	Fined 5/-.
Holding on to lorry	Boy, 16 years	Fined 5/-.
Shopbreaking	Boy, 13¾ years	Placed in care of Aunt in South Wales.
Shopbreaking	Boy, 11½ years	Dismissed P.O. Act.
Care and protection	Boy, 16¼ years	Remanded in custody.
Unlawful possession	Boy, 15 years	Remanded to 29/3/39.
Stealing and taking away motor car	Boy, 15 years	Fined 30/-.
Breaking and entering	Boy, 16 years	Remanded in custody to 29/3/39.
Beyond control	Girl, 16 years	Supervision Order six months.
At Willesden:—		
Larceny	Boy, 13¼ years	Dismissed P.O. Act.
Larceny	Boy, 16½ years	Probation 1 year.
At Chertsey:—		
Wilful damage	Boy, 16¼ years	Dismissed P.O. Act.
At Islington:—		
Fraud on Railway	Boy, 16 years	Dismissed P.O. Act. Costs 21/-.

Noted.

2.—SCHOOL ATTENDANCE:

(a) STATISTICS OF ATTENDANCE were submitted as follows:—

(i) Percentages:—

Week ended 24th February, 1939	88.2
Week ended 3rd March, 1939	87.5
Week ended 10th March, 1939	88.8

(ii) Statistics for the week ended 17th March, 1939:—

Number on Roll	14,322
Average Attendance	12,753
Percentage of Attendance	89.0

Noted.

(b) IRREGULAR ATTENDANCE:

Pursuant to Minute 2 (b) (ii) of this Sub-Committee, dated 28th February, 1939, a further report was now submitted.

RESOLVED TO RECOMMEND—

THAT a summons be issued against Mr. Johnson in respect of the irregular attendance of his four children (Leslie, Walter, Gwen and Winifred).

3.—EMPLOYMENT OF CHILDREN:

The report of the Employment Officer for the period 23rd February, 1939, to 22nd March, 1939, was submitted as follows:—

	Boys.	Girls.
Employment Cards and Badges Issued	21	—
Employment Badges Returned	8	1
New Permits granted:—		
Delivery of Newspapers	14	—
Delivery (Shops)	5	1
Delivery of Milk	3	—
Medically examined (Certificates granted)	11	—
Number of children employed at date	332	10

Noted.

4.—ASSOCIATION OF SUPERINTENDENTS OF SCHOOL ATTENDANCE DEPARTMENTS—TWENTY-THIRD ANNUAL CONFERENCE:

RESOLVED TO RECOMMEND—

THAT Councillor (Mrs.) Parvin and the Chief Attendance Officer be appointed to attend the Conference to be held at Torquay on 22nd, 23rd and 24th May, 1939, and that payment of expenses incidental thereto be approved.

[Having considered the matter in its financial bearing, the Finance and General Purposes Committee concur in the proposal.]

Moved by Councillor Hignett, seconded by Councillor Shakespeare, and

RESOLVED—

THAT the Report of the School Attendance Sub-Committee be approved and adopted.

FINANCE AND GENERAL PURPOSES SUB-COMMITTEE:

RESOLVED—

THAT the following Report be received:—

28th March, 1939.

SUB-COMMITTEE:

*Councillor A. W. Curton (*Chairman*).

Aldermen: *J. J. Copstake, J.P., *B. Flowers, B. J. Monro.
*S. H. Egan, J.P.

Councillors: *E. Arter, M.C., M.I.A.E., *C. R. Richardson, (Mrs.) M. Thomas.
*G. H. Hignett, W. H. N. Shakespeare,
*T. Pugh, M.C., A.F.C., J.P.,

* denotes Member present.

1.—SCHEME FOR THE AWARD OF MAINTENANCE ALLOWANCES:

Pursuant to Item 3 in the Report of this Sub-Committee, dated 31/1/39, a letter was submitted from the Board of Education approving, under Article 8 of the Elementary Grant Regulations No. 1, the Authority's proposal to continue up to 31st July, 1939, the award of Maintenance Allowances to pupils in public elementary schools in accordance with the Scheme at present in force. The Board are also prepared to approve the revised scheme which the Authority propose to bring into operation as from 1st September, 1939, subject to the amendments mentioned. **Noted.**

2.—DOLE STREET JUNIOR AND INFANT SCHOOL—OFFICIAL OPENING:

RESOLVED TO RECOMMEND—

THAT His Worship the Mayor (Councillor H. G. Potter, J.P.) be asked to open officially the Dole Street Junior and Infant School on a suitable date to be arranged, that an amount not exceeding £50 be sanctioned for incidental expenses in connection therewith and that all arrangements be left in the hands of the Mayor, the Chairman of the Education Committee and the Director of Education.

[Having considered the matter in its financial bearing, the Finance and General Purposes Committee concur in the proposal.]

3.—HENDON HEAD TEACHERS' ASSOCIATION:

A request from this Association for the supply of one typewriter to each School Department for correspondence purposes was submitted and **noted.**

4.—CRESSINGHAM ROAD PLAYING FIELD:

RESOLVED TO RECOMMEND—

THAT the use of the above-named Playing Field be granted to the Watling Association on 15th April and 24th June next, free of charge, subject to the usual safeguards and to the Education Committee being indemnified by the users against any claims which may fall against the Committee.

5.—ST. MARY'S C.E. SENIOR SCHOOL—PROPOSED SCHOOL JOURNEY:

Consideration was given to an application from the Headmaster for a grant under the School Journeys Scheme in respect of a proposed educational journey to Switzerland by pupils attending this school during the period 21st to 29th April, 1939.

RESOLVED TO RECOMMEND—

THAT the application be not granted.

6.—J.O.C. BOXING TOURNAMENT:

An application from the Caretaker for additional remuneration in respect of the recent J.O.C. Boxing Tournament held at Barnfield Council School was declined.

7.—CHILD GUIDANCE CLINIC, PAYMENT OF FARES:

RESOLVED TO RECOMMEND—

THAT authority be given to the Director of Education to arrange for the payment of such fares as he may deem necessary in respect of necessitous Elementary School Children who are required to attend the Child Guidance Clinic for treatment.

8.—WORKS SUB-COMMITTEE MATTERS:

The following items which had been sanctioned by the Works Sub-Committee were submitted and **approved**:—

Dole Street Junior and Infant School:—

	£	s.	d.
Nuswift Engineering Co. Ltd., Fire Extinguishers, etc.	23	8	0

Meads Infants' School:—

Repairs to Electric Light Fittings, etc.	85	0	0
---	----	---	---

9.—REQUISITIONS:

Requisitions which had been sanctioned by the School Management Sub-Committee (£610 19s. 2d.) and the Works Sub-Committee (£397 5s. 7d.) were submitted and **approved**.

Moved by Councillor Curton, seconded by Alderman Flowers, and **RESOLVED**—

THAT the Report of the Finance and General Purposes Sub-Committee be approved and adopted.

BROADFIELDS AVENUE JUNIOR AND INFANT SCHOOL—CORRESPONDENCE
WITH MESSRS. J. LAING AND SON LTD.:

Moved by Councillor Shakespeare, duly seconded, and **RESOLVED**—

THAT this matter be dealt with in Committee.

Report (No. 2) of the Education Committee (In Committee).

25th April, 1939.

COMMITTEE:

*Alderman J. J. Copestake, J.P. (*Chairman*).

Aldermen:

S. H. Egan, J.P.,
*B. Flowers,

*W. M. Maughan, J.P.,

B. J. Monro.

Councillors:

*E. Arter, M.C., M.I.A.E.,
*H. Connell, J.P.,
*A. W. Curton,
*C. H. Hignett,
*P. Lightfoot,

*A. A. Naar, M.B.E.,
*(Mrs.) F. E. Parvin,
*T. Pugh,
*C. R. Richardson,
*T. J. Scott,

*W. H. N. Shakespeare,
M.C., A.F.C., J.P.,
*H. P. Small,
(Mrs.) M. Thomas.

Co-opted:

*Mrs. S. J. Bannister,
L.L.A.,
*The Rev. N. R. Boyd,
M.A.,

*Major N. C. Brett
James, M.A.,
B.Litt., F.S.A.,

*The Rev. P. C. Howell,
*The Rev. I. Livingstone.

• denotes Member present.

Apologies for absence were submitted on behalf of Aldermen Egan and Monro.

BROADFIELDS AVENUE JUNIOR AND INFANT SCHOOL:

Pursuant to Resolution (c) in the Report of the Education Committee (in Committee) dated 20/3/39, correspondence was submitted between the Borough Surveyor and Messrs. J. Laing & Son, Ltd., regarding access to site and connection to existing sewer. The Surveyor reported thereon after which discussion ensued.

MOTION moved by Councillor Richardson, seconded by Councillor Connell:—

THAT no action be taken regarding completion of the Contract until the result of the arbitration proceedings is made known.

AMENDMENT moved by Councillor Shakespeare, seconded by Councillor Curton:—

THAT all necessary steps be taken for the completion of the Contract forthwith.

On submission to the meeting, the Chairman declared the amendment **not carried**.

On submission of the Motion, it was

RESOLVED—

THAT no action be taken regarding completion of the Contract until the result of the arbitration proceedings is made known.

THE MEADS JUNIOR MIXED SCHOOL—APPOINTMENT OF HEAD TEACHER:

The Committee interviewed six selected candidates for the post of Head Teacher of this school, and RESOLVED—

THAT Mr. William H. Bryant be appointed Head Teacher of the Meads Junior Mixed School for duty as from 1st May, 1939, in full-time service exclusively in the capacity of a teacher in accordance with the conditions of employment under Article 17 of the Code, and subject to the conditions of appointment of the Committee in force from time to time and upon the terms and subject to the conditions of the Burnham Arbitration Award and the decisions of the Board of Education relating thereto, or upon the terms and subject to the conditions of any other scale of salaries that may be adopted by the Committee, the engagement to be determinable on either side by a notice of three calendar months.

Report (No. 3) of the Education Committee.

2nd May, 1939.

COMMITTEE :

*Alderman J. J. Copestake, J.P. (*Chairman*).

Aldermen:

S. H. Egan, J.P.,
*B. Flowers,

*W. M. Maughan, J.P.,

*B. J. Monro.

Councillors:

*E. Arter, M.C., M.I.A.E.,
*H. Connell, J.P.,
*A. W. Curton,
*C. H. Hignett,
*P. Lightfoot,

*A. A. Naar, M.B.E.,
*(Mrs.) F. E. Parvin,
*T. Pugh,
*C. R. Richardson,
T. J. Scott,

W. H. N. Shakespear,
M.C., A.F.C., J.P.,
*H. P. Small,
(Mrs.) M. Thomas.

Co-opted:

(Mrs.) S. J. Bannister,
L.L.A.,
The Rev. N. R. Boyd,
M.A.,

Major N. C. Brett
James, M.A.,
B.Litt., F.S.A.,

*The Rev. P. C. Howell,
*The Rev. I. Livingstone.

* *denotes Member present.*

Apologies for absence were submitted on behalf of Alderman Egan, Mrs. Bannister and Major Brett James.

AIR RAID PRECAUTIONS IN SCHOOLS:

Moved by Alderman Copestake, seconded by Alderman Flowers, and RESOLVED—

THAT this matter be dealt with in Committee.

Report (No. 4) of the Education Committee (in Committee).

2nd May, 1939.

COMMITTEE:

*Alderman J. J. Copestake, J.P. (*Chairman*).

Aldermen:

S. H. Egan, J.P.,
*B. Flowers,

*W. M. Maughan, J.P.,

*B. J. Monro.

Councillors:

*E. Arter, M.C., M.I.A.E.,
*H. Connell, J.P.,
*A. W. Curton,
*C. H. Hignett,
*P. Lightfoot,

*A. A. Naar, M.B.E.,
*(Mrs.) F. E. Parvin,
*T. Pugh,
*G. R. Richardson,
T. J. Scott,

W. H. N. Shakespeare,
M.C., A.F.C., J.P.,
*H. P. Small,
(Mrs.) M. Thomas.

Co-opted:

(Mrs.) S. J. Bannister,
L.L.A.,
The Rev. N. R. Boyd,
M.A.,

Major N. G. Brett
James, M.A.,
B.Litt., F.S.A.,

*The Rev. P. C. Howell.
*The Rev. I. Livingstone.

• *denotes Member present.*

Apologies for absence were submitted on behalf of Alderman Egan, Mrs. Bannister and Major Brett James.

AIR RAID PRECAUTIONS IN SCHOOLS:

Correspondence between the Town Clerk and the Ministry of Health was submitted. A copy of Board of Education Circular No. 1467, dated 27th April, 1939, had been duly circulated to each Member of the Committee.

RESOLVED—

- (a) THAT the Minister of Health be asked to receive a deputation, comprising His Worship the Mayor, the Chairmen of the Education and Air Raid Precautions Committees, Alderman Maughan, Councillor Richardson, the Town Clerk and the Director of Education, for the purpose of urging that the Borough of Hendon be re-zoned and classified as an evacuation area.
- (b) THAT the Director of Education be instructed to prepare a preliminary scheme on the lines suggested in Board of Education Circular 1467 for consideration by this Committee.

Report of the Public Health and Medical Services Committee.

17th April, 1939.

COMMITTEE:

*Councillor T. J. Scott (*Chairman*).

Aldermen:

W. R. Clemens, F.C.A.,

*B. Flowers,

*W. M. Maughan, J.P.

Councillors:

*F. W. Gilpin,

*C. H. Hignett,

L. Hirshfield,

*P. Lightfoot,

*C. Pinkney,

*G. R. Richardson,

*H. P. Small.

(Mrs.) M. Thomas.

Co-opted Members:

Mrs. S. J. Bannister,
L.L.A.,

Mrs. W. M. Maughan,
Mrs. B. J. Monro, J.P.,

The Rev. P. G. Howell.

* denotes Member present.

(Owing to the Special Meeting of the Council, Mrs. W. M. Maughan and the Rev. P. G. Howell, both of whom had been present to attend the meeting of the Committee, were unable to wait.)

Part I.—Medical Services.

1.—DENTAL ATTENDANT:

The Committee interviewed selected applicants to fill the vacancy created by the resignation of Miss Hidson. (P.H. & M.S.C., 6/3/39—8).

RESOLVED TO RECOMMEND—That subject to the receipt of a satisfactory medical report, Miss Gladys Melsom of Holland Park be appointed on the permanent staff to the post of Dental Attendant at a commencing salary of £130 per annum, rising subject to satisfactory service by annual increments of £10 to £160, the engagement to be determinable by one month's notice on either side.

[*Having considered the matter in its financial bearing, the Finance and General Purposes Committee concur in the proposal.*]

2.—STATISTICAL INFORMATION:

Information as to Maternity and Child Welfare Services and attendances at Health Centres was submitted for the six weeks ended on the 8th April, 1939 (see statistical tables—Appendix to the report of the Finance and General Purposes Committee, page 9).

PUBLIC HEALTH ACT, 1936—CHILD LIFE PROTECTION.

3.—NEW APPLICATION:

The Medical Officer reported the receipt of application (Case No. 268) to undertake for reward the nursing and maintenance of a child under nine years of age.

RESOLVED TO RECOMMEND—That the maximum number of children under the age of nine years that may be kept at the premises in question be fixed at one.

4.—CHANGE OF ADDRESS:

Notification of change of address (Case No. 197) was reported.

RESOLVED TO RECOMMEND—That the maximum number of children under the age of nine years that may be kept at the new premises be fixed at two.

PUBLIC HEALTH ACT, 1936—NURSING HOMES.

5.—RUPERT HOUSE, STONE GROVE, EDGWARE:

The Misses Elizabeth and Ann Jones were registered by the Middlesex County Council for the use of the above premises as a Nursing Home and a request has now been received from Miss Jones to be registered in respect of an additional room on the first floor of the premises.

Having considered a report from the Medical Officer of Health,

RESOLVED TO RECOMMEND—That the application be not granted.

6.—21, GREEN WALK, HENDON:

A report was received from the Medical Officer with regard to a further inspection of the above premises occupied by Mrs. Mackman. (P.H. & M.S.C., 9/1/39—5).

RESOLVED TO RECOMMEND—That Mrs. Mackman be informed that unless she complies within a period of 28 days, with the provisions of the Public Health Act, 1936, relating to the registration of the premises as a Nursing Home, legal proceedings will be instituted.

7.—CONVALESCENT TREATMENT:

The Medical Officer reported with regard to the case of Mrs. K., Burnt Oak.

RESOLVED TO RECOMMEND—That arrangements be made for her to be sent away with her child for a period of six weeks' convalescence.

8.—PUERPERAL PYREXIA REGULATIONS, 1939:

The above regulations have been made by the Minister of Health under powers conferred by Section 143 of the Public Health Act, 1936. Hitherto a rise of temperature following child-birth could be notified as Puerperal Fever or Puerperal Pyrexia, but the first named has been omitted from the list of notifiable diseases in the Public Health Act, 1936. Only one clinical condition is therefore now recognised, viz.:—"Puerperal Pyrexia" and the regulations in question have been made to clarify the position.

A statutory form of certificate has been prescribed which differs somewhat from the previous form, and it is anticipated that this will result in an additional number of bacteriological investigations being undertaken.

The Medical Officer stated that local authorities are required to advertise these provisions and to forward a copy of the regulations to every medical practitioner practising in the district. **Noted.**

9.—HEALTH AND CLEANLINESS COUNCIL:

A communication was reported from the above organisation expressing the hope that the Council would renew their subscription of £1 1s. 0d. (P.H. & M.S.C., 15/11/37—13).

RESOLVED TO RECOMMEND—That a further donation of £1 1s. 0d. be made to the funds of the Health and Cleanliness Council.

[Having considered the matter in its financial bearing, the Finance and General Purposes Committee concur in the proposal.]

10.—PARK SHELTERS:

The Committee adjourned consideration of a communication from the National Society of Day Nurseries on the subject of Park Shelters for the benefit of children under five years of age.

11.—A GENERAL MEDICAL SERVICE FOR THE NATION:

A copy of a booklet issued by the British Medical Association was circulated to the Members of the Committee and duly noted.

12.—PERSONAL SERVICE COMMITTEE:

A communication was submitted from the Watling Association intimating that the above Committee was being re-formed and inviting the appointment of a Member to represent the Public Health and Medical Services Committee.

It was stated that the Committee has previously dealt with a number of cases requiring help of various kinds and they endeavour to co-operate with other organisations engaged in similar work.

RESOLVED TO RECOMMEND—That Councillor C. Pinkney be appointed to serve on the Personal Service Committee on the Watling Estate.

13.—HEALTH CENTRES—REPORT OF ROTA:

The following report was submitted:—

To the Public Health and Medical Services Committee.

Central Hendon, Child's Hill, Temple Fortune and Watling Health Centres.

We, the undersigned members, submit the following report of a visit made to the above-named Centres on Tuesday, 28th March, 1939.

We found all the Centres working satisfactorily. Being a wet afternoon the attendances were small.

We noted the lack of Dental Attendants but the Medical Officer of Health has the matter in hand.

We concluded our afternoon by a visit to the Hendon Day Nursery and were much impressed by the way it had all been re-decorated, which certainly improved the conditions under which the Nursery is run.

There was a large pool of water immediately in front of the outside food safe and we are asking the Borough Surveyor to have this attended to.

(Signed) T. J. SCOTT (Chairman).

P. G. HOWELL.

RESOLVED TO RECOMMEND—That the report of the Rota be approved and adopted.

14.—MIDWIFERY SERVICE IN A NATIONAL EMERGENCY:

A communication was submitted from the Central Midwives Board intimating that owing to movements of population or to the transfer of doctors and nurse-midwives to other work there may be increased demands for midwives in certain districts. With a view to assisting local supervising authorities to meet any such increased demand, the Board is compiling a register of women, whose names are on the current Roll of Midwives, and who would be free and willing, in a national emergency, to undertake midwifery work either in their home districts or anywhere in the country.

Particulars were submitted with regard to the contents of the proposed register and the following information was sought by the Central Midwives Board:—

- (i) the number of midwives (a) municipal, (b) employed by voluntary institutions and associations, (c) independent practising in the area of your authority at the present time, who are under obligation to undertake in a national emergency service other than midwifery (for example, as members of the Territorial Army Nursing Service);
- (ii) whether, in the opinion of your authority, the midwives at present practising in its area would be able to cope with an increased number of maternity cases which may require attendance in the area in a national emergency. If in those cases in which the view is held that the services of additional midwives will be required, an estimate, however rough, could be supplied of the number of midwives likely to be needed, such an estimate would be of considerable assistance.

It was intimated that this information would enable the Central Midwives Board to form some idea of the total number of volunteers it should endeavour to secure and also to relate the register in a preliminary way to the possible local needs.

With regard to volunteers who have not practised midwifery for a number of years and have expressed a desire to receive some post-certificate instruction, the Board has asked the Midwives' Institute if it could undertake to arrange through its local branches, a scheme of suitable courses. Details of such a scheme will be furnished in due course.

RESOLVED TO RECOMMEND—That the Medical Officer of Health be authorised to furnish the information desired by the Central Midwives' Board.

15.—REQUISITIONS:

Requisitions amounting to the sum of £569 14s. 0d. were submitted and **approved.**

Part II.—Medical Services, for approval by the Hendon Education Committee.

(See Education Minutes, Pages 643-645).

Part III.—Public Health.

16.—STATISTICAL INFORMATION:

Information was submitted for the six weeks ended on the 8th April, 1939. (See statistical tables—Appendix to the report of the Finance and General Purposes Committee, page 9).

17.—MILK AND DAIRIES (CONSOLIDATION) ACT, 1915: MILK AND DAIRIES (AMENDMENT) ACT, 1922. MILK AND DAIRIES ORDER, 1926:

Applications were reported from the under-mentioned for registration as retail purveyors of milk within the Borough:—

Name and Address of Applicant.	Source of Milk Supply.
Ivor George Baber, 42, Glengall Road, Edgware, as a retail purveyor of milk in respect of the premises named	Bladen Dairies, Millbourne St. Andrew, Dorset. (Milk in sealed cartons only.)
Fanny Eichorn, 3, Mowbray Parade, Edgware Way, in respect of the premises named	Express Dairy Company, Deans Lane Depôt. (Bottled milk only.)
Diana Graber, 66, Vivian Avenue, Hendon, in respect of the premises named	Express Dairy Company, Central Hendon Depôt. (Bottled milk only.)

Huntleys (Mill Hill), Ltd., 4, Bittacy Hill, Mill Hill, in respect of the premises named

Bladen Dairies, Millbourne St. Andrew, Dorset. (Milk in sealed cartons only.)

RESOLVED TO RECOMMEND—That the applicants be registered accordingly.

18.—STATUTORY NOTICES:

RESOLVED TO RECOMMEND—That Statutory Notices be served in the following cases:—

Section 93, Public Health Act, 1936:—

27, Willifield Way, Golders Green

Mr. H. C. Millard, 4, Farm Walk, Golders Green.

Waste Land adjoining 27, Hermitage Lane, Child's Hill

Mr. Herbert Cook, 2, Ashcombe Gardens, Edgware.

9, Eagle Lodge, Golders Green Road, Golders Green

Messrs. C. H. Leeland, 22, Bulstrode Street, W. 1.

57, Highfield Avenue, Golders Green

Mrs. A. Rosen, 18, Alvanley Gardens, N.W. 6.

6, Yew Grove, Cricklewood

Messrs. Gammell & Co., 102, Cricklewood Broadway.

28, Ash Grove, Cricklewood

Messrs. Hillyer & Hillyer, 270/272, West Green Road, N. 15.

14a, Second Avenue, Hendon

Mrs. S. King, 9, Albert Road, Hendon.

41, Victoria Road, Hendon

Mrs. Summerfield, 22, Church Lane, Hampstead, N.W. 3.

6, Garrick Road, West Hendon

Ernest Owers Ltd., The Estate Offices, West Hampstead Station (Met.), N.W. 3.

3, Carlton Flat, Herbert Road, West Hendon

Mrs. Grenfield, 9, Quadrant Close, Hendon.

11 and 13, New Brent Street, Hendon

Mr. B. Walker, 32, Finchley Lane, Hendon.

85, Ravenstone Road, West Hendon

Miss M. Wright, 92, Audley Road, Hendon.

58, Great North Way, Hendon

Mr. C. A. Chappel, Bramley Cottage, Lyndhurst Drive, Harpenden.

348, Watford Way, Hendon

Mr. J. Link (occupier).

Section 45, Public Health Act, 1936:—

57, Highfield Avenue, Golders Green

Mrs. A. Rosen, 18, Alvanley Gardens, N.W. 6.

Section 141, Public Health Act, 1936:—

28, Ash Grove, Cricklewood

Messrs. Hillyer & Hillyer, 270/272, West Green Road, N. 15.

19.—SHOPS ACT, 1934:

A report on the subject of the provision of sanitary or other arrangements in shops has been deferred until the next meeting.

20.—REGISTRATION OF HAWKERS AND HAWKERS PREMISES:

The following applications were reported:—

Jack Taylor, 37, Hutton Road, S.E. 11.

Robert W. Glass, 948, High Road, N. 12.

Eric Arthur Dorrington Apthorp, 3, Copthall Gardens, Mill Hill.

RESOLVED TO RECOMMEND—That the aforesaid persons and/or premises be registered with the Local Authority in accordance with the requirements of Section 71, Middlesex County Council (General Powers) Act, 1938.

21.—WATER SUPPLIES:

A copy of Ministry of Health Memorandum No. 221 has been circulated to the Members of the Committee as directed and will be considered at the next meeting.

On the subject of London Underground Water in respect of which a communication was reported at the last meeting from the Ministry of Health, the Medical Officer reported the existence of a well at the North Middlesex Gas Company's Works, Mill Hill.

RESOLVED TO RECOMMEND—That a copy of the Medical Officer's Report be transmitted to the Ministry of Health.

ISOLATION HOSPITAL.

22.—STAFF SALARIES:

The Medical Superintendent reported that difficulty has been experienced in obtaining suitable applicants for the position of Staff Nurse and that despite repeated advertisements it had been necessary to engage the services of temporary nurses.

The present salary scale is £65 x £5 to £75 per annum.

Difficulties have also been encountered in filling the post of Assistant Cook and Senior Kitchenmaid, the salary being £50 x £5 to £60 and the Medical Superintendent asked for consideration to be given to the salaries of the Cook and Sewing Maid who are at the maximum of their scale, viz.:—£75 and £60 per annum respectively.

RESOLVED TO RECOMMEND—

- (1) **That the following salary scales for the Staff Nurses be approved:—**

Staff Nurses (Fever trained), £75 by £5 to £85 per annum.

Staff Nurses (General and Fever trained—two only), £85 by £5 to £95 per annum

and that the present staff be placed at the positions in the new scale which they would have reached had such scale been in force during the whole of their service in the employment of the Council.

- (2) **That authority be given for an advertisement to be issued for the position of Assistant Cook and Senior Kitchen Maid at the maximum of the grade, viz.:—£60 per annum.**
- (3) **That the Cook and Sewing Maid be granted two further increments of £5 per annum making the maximum salary for their appointments £85 and £70 respectively.**

[Having considered the matter in its financial bearing, the Finance and General Purposes Committee concur in the proposal.]

23.—SURGICAL UNIT:

A communication was submitted from the Ministry of Health approving generally the Council's amended proposals (P.H. & M.S.C., 9/1/39—26) for the provision of operative facilities at the Isolation Hospital. The Minister awaits the receipt of a revised estimate of cost based on the provisionally accepted tender and other relative documents. **Noted.**

24.—CONSULTING SURGEON:

A communication from Mr. Trevor Jones on the subject of fees has been deferred until the next meeting.

25.—ROTA REPORT:

The following report was submitted:—

To the Public Health and Medical Services Committee.

We, the undersigned members, submit the following report of a visit made to the above-named hospital on Monday, 27th March, 1939.

We inspected the various wards and cubicle block and found there were several items requiring repair—especially plaster and woodwork. We noticed particularly that the plaster was coming away from the woodwork in several of the wards and that in one place in the cubicles there was a suspicion of dry rot. We have asked the Medical Superintendent to get in touch with the Borough Surveyor with regard to the repair of these items.

Apart from the above we found everything satisfactory and in good working order.

Signed) T. J. SCOTT (Chairman).

W. M. MAUGHAN.

RESOLVED TO RECOMMEND—That the report of the Rota be approved and adopted.

26.—REQUISITIONS:

Requisitions amounting to the sum of £80 15s. 5d. were submitted and **approved**.

27.—CONFERENCE:

It was decided to take no action with regard to a communication from the National Association for the Prevention of Tuberculosis inviting the Council to appoint delegates to attend the Annual Conference at Belfast from June 29th—July 1st, 1939.

28.—FOULING OF FOOTPATHS BY DOGS:

The following suggestions were submitted by the Hampstead Garden Suburb Residents' Association:—

1. *That a notice be sent out with Rate Demands, calling householders' attention to this nuisance and appealing to them to effect an improvement; such notices not to threaten penalties but to appeal to good feeling and public spirit.*
2. *That road scavengers be directed to clean footpaths at the same time as roads.*

The Committee have no recommendation to make on the question of the issue of notices with the rate demands and have referred the other suggestion to the Highways Committee.

Report of the Highways Committee.

17th April, 1939.

COMMITTEE :

*Councillor A. W. Curton (*Chairman*).

Aldermen:

*J. J. Copestake, J.P.,

*A. J. Reynolds, J.P.,

*F. C. Rice.

Councillors:

E. Arter, M.C., M.I.A.E.,

*J. Griffiths,

*G. J. Pryke, F.I.A.C.,

H. Connell, J.P.,

*A. A. Naar, M.B.E.,

A.M.I.S.E.,

*A. W. Greville,

H. G. Potter, J.P., F.S.I.

*C. F. Windust.

(*Mayor*),

• denotes Member present.

1.—REQUISITIONS:

Requisitions amounting to £6,789 12s. 10d. were submitted and **approved**.

STREET TRADING.

2.—WATLING AVENUE:

The deputation from the Hendon Chamber of Commerce duly attended for interview with the Committee, but in view of delay in the meeting of the Committee, owing to the pressure of business at the Special Council Meeting, the deputation were unable to keep their appointment with the Committee.

In these circumstances the Committee have adjourned consideration of the matter to enable the deputation to attend the next meeting of the Committee.

3.—APPLICATIONS FOR LICENCES:

Applications were considered from:—

- (i) Mrs. L. Marshall for a licence to sell confectionery from a stall or barrow in a stationary position on the carriageway of Pursley Road, opposite its junction with Brookfield Avenue, Mill Hill.
- (ii) Mr. P. A. Lavin for a licence to sell confectionery from a stall or barrow in a stationary position on the carriageway of Pursley Road near its junction with Dole Street.

The Committee also considered reports of the Commissioner of Police and the Borough Surveyor on the matter.

RESOLVED TO RECOMMEND—That such applications be disapproved.

PRIVATE STREET WORKS.

4.—HILLVIEW ROAD, MILL HILL:

The Borough Surveyor reported on a letter from Miss E. C. Bloom of Hillview Road, complaining of the condition of the road. In view of the fact that the road has not yet been fully developed, it is inadvisable at the present time to make it up under the Public Health Act, 1875.

RESOLVED TO RECOMMEND—That no action be taken in the matter.

5.—SOUTHOVER, WOODSIDE PARK ESTATE:

The Committee considered the undermentioned tenders received for the making up of the above road:—

	£	s.	d.
Howard Farrow Ltd.	725	10	2
D. R. Paterson Ltd.	702	15	10
Mr. Chas. Carter	684	11	1

The approximate cost of the Council's liability in the matter is £500 (H.C., 6/3/39—6).

RESOLVED TO RECOMMEND—

- (i) **That the lowest tender, viz., that of Mr. Chas. Carter amounting to £684 11s. 1d. be accepted.**
- (ii) **That the Corporate Seal be affixed to any necessary documents in connection with the contract for carrying out the works.**

[Having considered the matter in its financial bearing, the Finance and General Purposes Committee concur in the proposal.]

6.—GREEN CLOSE, FAIRWAY CLOSE, RAEBURN CLOSE (PART OF) AND CONSTABLE CLOSE, HAMPSTEAD GARDEN SUBURB:

The Borough Surveyor reported on a letter from Mr. J. C. S. Soutar suggesting that the above roads, all of which have an overall width of 22 feet, enabling a 13 feet carriageway and two footpaths each 4 feet 6 inches to be provided, should be included in the same group with Ingram Avenue and Wilwood Rise for making up under Section 150 of the Public Health Act, 1875.

RESOLVED TO RECOMMEND—That plans and estimates be prepared for the making up of such roads accordingly.

7.—MANOR HALL AVENUE, MANOR HALL DRIVE, TALBOT CRESCENT AND WOODWARD AVENUE, HENDON:

The Town Clerk reported the receipt of letters from the Minister of Health regarding the making up of the above roads, and intimating that he is prepared to give further consideration to the Council's applications for sanction to loans upon receipt of information as to the tenders received for the execution of the works, together with an indication as to those proposed to be accepted (H.C., 19/9/38—9 and 14/11/38—11).

RESOLVED TO RECOMMEND—That tenders be invited for carrying out the necessary works.

TRAFFIC.

8.—BARRIER RAILS, JUNCTION OF BARNFIELD ROAD WITH WATLING AVENUE:

The Borough Surveyor reported that the total estimated cost of the provision of barrier rails including fixing and reinstatement of paving at the above junction is £50 (H.C., 6/3/39—14).

RESOLVED TO RECOMMEND—That subject to the approval of the Minister of Transport the estimate be approved and the Borough Surveyor authorised to arrange for the erection of such barrier rails.

[Having considered the matter in its financial bearing, the Finance and General Purposes Committee concur in the proposal.]

9.—LIGHTING OF TRAFFIC SIGNALS, SIGNS, ETC.:

The Town Clerk after consultation with the Borough Treasurer reported with regard to the suggestion of the Hendon Electric Supply Co., Ltd., that they should be indemnified against any claim received arising out of or in connection with any failure to maintain a continuous supply of electricity to traffic signals, signs, etc. It would appear that the liability for any claim would fall upon the Council, and the Committee are of opinion that it is desirable that the Company should, on the contrary, indemnify the Council against any failure on this service (H.C., 6/3/39—8).

RESOLVED TO RECOMMEND—That the Company be informed accordingly.

[Having considered the matter in its financial bearing, the Finance and General Purposes Committee concur in the proposal.]

10.—PEDESTRIAN CROSSING, MONTROSE AVENUE, EAST OF THE GREENWAY:

The Town Clerk reported the receipt of a letter from the Minister of Transport pursuant to Section 48 (1) of the Road Traffic Act, 1930, approving a pedestrian crossing at Montrose Avenue, east of The Greenway.

RESOLVED TO RECOMMEND—That the Borough Surveyor be authorised to arrange for the necessary work to be undertaken in connection with the establishment of a pedestrian crossing at this point.

[Having considered the matter in its financial bearing, the Finance and General Purposes Committee concur in the proposal.]

11.—PEDESTRIAN CROSSING, FINCHLEY ROAD:

A letter was submitted from the Middlesex County Council intimating that the County Highways Committee had considered and approved the provision of a pedestrian crossing in Finchley Road, south of the Orpheum Theatre at an estimated cost of £15: the County Council to defray a moiety of the balance of the cost after deducting the Ministry of Transport grant subject to the Town Council meeting the remainder of the cost. **Noted.**

12.—SPEED LIMIT—HENDON WAY—WATFORD WAY, HENDON:

The Town Clerk reported the receipt of a letter from the Minister of Transport intimating that he has examined the traffic conditions prevailing in the section of Hendon Way/Watford Way between Park Road and The Burroughs, Hendon, and has decided to give Notice of his intention to make an Order under Section 1 of the Road Traffic Act, 1934, imposing a speed limit in the length of road in question. A copy of the draft Order is forwarded and any observations which the Council may desire to make, should be forwarded not later than the 24th instant. **Noted.**

PUBLIC LIGHTING.

13.—CONTRACTS:

The Borough Surveyor has reported, for information, that the general lighting Contracts with the various Public Lighting Companies expire as follows:—

The Gas Light & Coke Co.	30th September, 1939.
The North Middlesex Gas Co.	31st August, 1941.
The North Metropolitan Electric Power Supply Co.			4th April, 1942, or may be determined by 6 months' notice on the 4th April, 1940.

Noted.

14.—ASSOCIATION OF PUBLIC LIGHTING ENGINEERS—CONFERENCE, GLASGOW:

A letter was considered from the Secretary of the above Association inviting the Council to appoint delegates to attend the Annual Meeting and Conference to be held at Glasgow from the 4th to the 8th September, 1939. The registration fee for one or more delegates attending is £2 2s. 0d.

RESOLVED TO RECOMMEND—That no action be taken.

IMPROVEMENT SCHEMES.

15.—HOLDERS HILL ROAD IMPROVEMENT:

The Town Clerk reported the receipt of a letter from the Middlesex County Council approving additional expenditure amounting to £1,415. (Hi.C., 6/2/39—23). **Noted.**

16.—FINCHLEY ROAD IMPROVEMENT (PORTSDOWN AVENUE TO CRICKLEWOOD LANE):

The Borough Surveyor reported that satisfactory progress is being maintained in connection with this improvement and details of the work proceeding on the various sections of the road were submitted. (Hi.C., 6/3/39—21). **Noted.**

17.—FRITH LANE IMPROVEMENT:

The Borough Surveyor reported on a letter from the Hendon Ratepayers' Association calling attention to the condition of Frith Lane and suggesting that a clinker path should be constructed on one side of the road for the safety of children attending Frith Manor School.

The Committee, however, anticipate that the Frith Lane Improvement Scheme will shortly be undertaken, and in these circumstances

RESOLVED TO RECOMMEND—That the Association be informed that the Council are unable to approve their suggestion.

DEDICATION OF LAND.

18.—LAND—SOUTH—WEST SIDE OF HENDON WOOD LANE:

The Town Clerk asked for authority to pay the reasonable legal costs in connection with the dedication of portions of six plots of land fronting Hendon Wood Lane, arising out of the approval of Building Applications Nos. A.6112 and A.7606, and also in connection with contemplated development by Haseldine & Co.'s Clients of the adjoining land. (Hi.C., 9/1/39—30).

RESOLVED TO RECOMMEND—That subject to the approval of the Middlesex County Council, authority be given for the payment of such legal costs.

[Having considered the matter in its financial bearing, the Finance and General Purposes Committee concur in the proposal.]

TRAVELLING FACILITIES.

19.—EDGWARE ROAD AND EDGWARE WAY, EDGWARE—STOPPING PLACES:

The Town Clerk reported the receipt of letters from the Minister of Transport regarding the provision of stopping places in

Edgware Road at Whitechurch Lane,

Edgware Way at Spur Road,

and the Committee have no observations to offer on the proposals.

20.—BANNER, HAMPSTEAD WAY, GOLDERS GREEN:

The Borough Surveyor reported on a letter from the Play and Pageant Union asking for permission to suspend a banner approximately 20 feet long by 3 feet deep across the end of Hampstead Way near Finchley Road during the two weeks from the 10th and 24th June. The Union are prepared to insure against the risk of accidents.

RESOLVED TO RECOMMEND—That permission be given, subject to the applicants indemnifying the Council against liability in connection therewith.

21.—REINSTATEMENT OF TRENCHES FOR STATUTORY COMPANIES:

The Borough Surveyor reported on a letter from the Middlesex County Council regarding the reinstatement of trenches made by Contractors during the progress of road works. It is the practice of public utility companies, on being informed of contemplated improvements or surfacing works, to take the opportunity of renewing their mains and cables after the top surface has been removed by the Council's Contractors. This practice causes a certain amount of dislocation in the Contractor's work and the Companies have, in the past, stated that they are not liable for reinstatement charges.

The County Engineer has had a meeting with the Engineers of the Companies concerned and come to an arrangement whereby the Notices of opening are to be sent in the usual way and the Companies are to pay 40 per cent. of the schedule rates for reinstating the surface which existed prior to any work being commenced. The County Engineer suggests that it is desirable that all Local Authorities, especially those acting as agents for the County Council, should adopt the same arrangement with statutory companies in respect of improvement works on County Roads where the cost of trench reinstatement is reimbursed by the County Council. There would not appear to be any objection to the suggestion, and

RESOLVED TO RECOMMEND—That the suggestion be approved and adopted.

[Having considered the matter in its financial bearing, the Finance and General Purposes Committee concur in the proposal.]

22.—TENDER FOR TARRED MACADAM:

The Council (Hi.C., 6/2/39—33) has accepted one tender for the supply of tarred macadam, viz., that of The Clay Cross Company Ltd., and in this connection the Borough Surveyor reported that it would be of convenience to have a second tender, as the accepted Company cannot always deliver at the required time. Constable, Hart and Co., Ltd., are prepared to enter into a contract without any qualifying clause to supply tarred macadam on the following terms:—

	Delivered per ton to Highways.	
	£	s. d.
Tarred slag macadam, 2½ inch gauge	1	2 11
Tarred slag macadam, 1½ inch gauge	1	3 8
Tarred slag macadam, ¾ inch gauge	1	4 2
Tarred slag macadam, ¾ inch gauge	1	5 5
Derbyshire limestone tarpaving, 1½ inch gauge	1	2 0
Derbyshire limestone tarpaving, ¾ inch gauge	1	5 3

RESOLVED TO RECOMMEND—That the tender of Constable, Hart & Co., Ltd., be accepted and the Corporate Seal affixed to the necessary contract.

**Having considered the matter in its financial bearing, the Finance and General Purposes Committee concur in the proposal.]*

Report of the Estates, Parks and Allotments Committee.

17th April, 1939.

COMMITTEE:

*†Councillor F. J. Collins (*Chairman*).

Aldermen:

*†S. H. Egan, J.P.
(*Deputy Mayor*),

B. J. Monro,

*†R. A. B. Teare, M.B.E.

Councillors:

*†F. H. Bate,
*†E. J. Cox,
W. A. Hicks,

*†(Mrs.) F. E. Parvin,
*†T. Pugh,
*†J. H. Rodway,

*†W. H. N. Shakespeare,
M.C., A.F.C., J.P.

Co-opted Members:

†H. J. Ellner,

†T. W. Hammond,
†P. Kneip,

†G. Thompson.

* denotes Member present.

† Denotes Member present at Allotments Committee.

1.—REQUISITIONS:

Requisitions amounting to £365 17s. 8d. were submitted and **approved**.

2.—COPTHALL PARK—CRICKET TABLE:

A letter was submitted from the Hendon Preparatory School regarding the renewal of facilities for cricket at the Copthall Playing Fields. The School point out that the cricket table previously provided was not ideal and enquire whether the Council would be prepared to lay down a concrete table for their use.

RESOLVED TO RECOMMEND—

- (i) **That the Borough Surveyor be instructed to lay a concrete cricket table in Copthall Playing Fields at an estimated cost of £15.**
- (ii) **That Hendon Preparatory School be granted the use of the concrete pitch subject to a necessary adjustment of rent.**

[*Having considered the matter in its financial bearing, the Finance and General Purposes Committee concur in the proposal.*]

3.—MONTROSE PLAYING FIELDS—RUNNING TRACK:

In accordance with the Committee's instructions (E.P. & A.C., 6/3/39—12) the Borough Surveyor submitted a plan of the proposed running track encircling a football pitch and situate on the north-east side of the Playing Fields parallel to the London Electric Railway and adjacent to the Montrose Allotments.

The track is designed to provide four laps to the mile, is twenty-four feet wide and has a straight section for the 100 yards flat and 120 yards hurdles. The proposal involves a considerable amount of excavation by a mechanical appliance; re-siting of a football pitch; moving one cricket table and two concrete practice tables; the felling of six trees; and the diversion of 150 feet of footpath. The area of the track and the ground enclosed would need re-draining but an outlet for sub-soil water could be made into the stream which forms the boundary of the Montrose Allotments.

The estimated cost of constructing the track, together with the consequential works is £1,340.

RESOLVED TO RECOMMEND—

- (1) That the plans and estimates amounting to £1,340 for the construction of a running track in Montrose Playing Fields be approved.
- (2) That the Finance and General Purposes Committee be requested to make the necessary financial provision.

Amendment

Before detailed consideration of the matter, the Finance and General Purposes Committee Recommend—That Recommendation (2) be deleted and the following substituted :—

"That application be made to the Minister of Health for sanction to the borrowing of the sum of £1,375 for a period not exceeding 5 years as follows :—

<i>Cost of works</i>	£1340
<i>Cost of raising loan</i>	35
		£1375"

4.—HORSE RIDING IN PARKS:

A letter was submitted from Mrs. M. Elven asking the Council to allow horse riders a twenty-five yard track round the Cophall Playing Fields and Arrandene Open Space.

Facilities have already been granted for Arrandene Open Space (E.P. & A.C., 16/5/38—4) for a period of twelve months and the Committee intend to review the arrangements at their next meeting. (E.P. & A.C., 6/2/39—7).

RESOLVED TO RECOMMEND—That Mrs. M. Elven be informed accordingly.

5.—APPRENTICESHIP SCHEME:

An application was received from Mr. S. Goodrich of 217, Watling Avenue, Burnt Oak on behalf of his son in connection with the Apprenticeship Scheme. (E.P. & A.C., 27/6/38—3).

RESOLVED TO RECOMMEND—That the application for apprenticeship be approved subject to Mr. S. Goodrich, Junior, passing a satisfactory medical examination.

6.—SHELTER—WATLING AVENUE AND ORANGE HILL ROAD:

Pursuant to instructions (E.P. & A.C., 6/2/39—12) the Borough Surveyor submitted a plan for the construction of a shelter in the small open space at the junction of Watling Avenue and Orange Hill Road, opposite the main entrance to Watling Park.

Seating accommodation is proposed on three sides of the shelter, the fourth side being left blank as it faces the wall of the shops in Watling Avenue.

The estimated cost of the work, together with the necessary reinstatement to the paths, etc., is £110. Provision has been made for this shelter in the Rate Estimates, 1939/40.

RESOLVED TO RECOMMEND—That the plan and estimates amounting to £110 for the erection of a shelter be approved and that the Borough Surveyor be instructed to proceed with the works.

[Having considered the matter in its financial bearing, the Finance and General Purposes Committee concur in the proposal.]

7.—PARKS TRACTOR:

The following quotations were submitted:—

	£	s.	d.
Allan Taylor Engineering and Manufacturing Co., Wandsworth	705	18	0
H. Pattison & Co., Ltd., Stanmore	674	10	0
Spurling Motors, Hendon	615	2	0

It was originally intended that the new tractor should replace two old tractors, but no allowance for part exchange has been included in the quotation as it has been found desirable to retain them. The sum of £600 is included for the purchase of the tractor in the Rate Estimates, 1939/40.

RESOLVED TO RECOMMEND—

- (1) That the quotation of Spurling Motors amounting to £615 2s. 0d. be accepted.
- (2) That the Corporate Seal be affixed to any necessary documents.

Addendum

It has been reported to the Finance and General Purposes Committee that it is proposed that the two old tractors shall be retained for the purposes of training volunteers as ambulance drivers under the Air Raid Precautions Scheme and before detailed consideration of the motion the Committee recommend that the following be added:—

- (3) *That application be made for the consent of the Middlesex County Council for the transfer of the two old tractors for training purposes under the Air Raid Precautions Scheme.*

8.—FENCING:

The following quotations were submitted for the supply and erection of fencing in various parks and open spaces as provided for in the Rate Estimates:—

Watling Park and Sunny Hill Park:—

Chain link fencing 4 feet 6 inches in height:—

	£	s.	d.
Penfold Fencing Ltd., Watford	55	13	0
Prove Bros., Ltd., Watford	54	14	11

Watling Park, Colindale Park, Woodcroft Park, Elm Park, Clitterhouse Playing Fields, Princes Park:—

Light wrought iron hurdle fencing 1 foot 6 inches in height:—

T. Bowen Ltd., Wolverhampton	149	7	6
Bayliss, Jones & Bayliss Ltd., Wolverhampton	138	15	0
Penfold Fencing Ltd., Watford	138	2	6
Hill & Smith Ltd., Brierly Hill	134	13	5
Prove Bros., Ltd., Watford	103	18	0

RESOLVED TO RECOMMEND—That the quotations of Prove Bros., Ltd., amounting to £54 14s. 11d. and £103 18s. 0d. be accepted.

[Having considered the matter in its financial bearing, the Finance and General Purposes Committee concur in the proposal.]

9.—HENDON GROVE—FENCING:

The Borough Surveyor reported that the fencing on the western boundary of Hendon Grove is now in a dilapidated condition. The posts are broken down and the wire lying in the grass constitutes a source of danger to the public.

The estimated cost of erecting a wrought iron fencing 5 feet 6 inches in height is £230.

This matter has been before the Council on several occasions and apart from the Borough Surveyor taking such steps as may be necessary to remove any source of danger to the public using the property, the Committee

RECOMMEND—That no further action be taken in the matter.

10.—TREES—BUNNS LANE:

A letter was received from the Copthall Residents Association expressing appreciation of the improvement in Bunns Lane and of the efficient and prompt manner in which the tree planting was carried out. **Noted.**

11.—BOWLING GREEN—MILL HILL PARK:

A letter was submitted from the Mill Hill Ladies' Bowling Club accepting the terms suggested by the Council for the use of three rinks on the old bowling green in Mill Hill Park. (E.P. & A.C., 6/3/39—9).

The Ladies' Club also state that they have now been informed by the Mill Hill Bowling Club that they will be unable to use the pavilion on Saturdays, Sundays and Bank Holidays and in case of rain an enquiry has been made as to whether the Council are prepared to erect a temporary hut for shelter, dressing accommodation and storage.

RESOLVED TO RECOMMEND—That the Borough Surveyor submit a report on the provision of a temporary hut for use by the Mill Hill Ladies' Bowling Club.

12.—THE BURROUGHS:

Reference was made to the general appearance and the very high standard of cultivation which has been achieved in the small open spaces at The Burroughs.

RESOLVED TO RECOMMEND—That the Parks Superintendent and his staff be congratulated on the high standard of cultivation and maintenance of the Open Spaces at The Burroughs.

13.—INSTITUTE OF PARKS ADMINISTRATIONS (INCORPORATED):

A letter was submitted from the Institute of Parks Administration (Incorporated) inviting the Council to appoint delegates to attend the Annual Conference to be held at Blackpool from the 4th—7th September next.

RESOLVED TO RECOMMEND—That the Chairman (Councillor F. J. Collins) and Mr. H. Erith, F.R.H.S. (the Council's Parks Superintendent) be appointed to attend the Conference.

[Having considered the matter in its financial bearing, the Finance and General Purposes Committee concur in the proposal.]

ALLOTMENTS COMMITTEE.

14.—ALLOTMENTS AND ALLOTMENT GARDENS:

A circular letter was submitted from the Minister of Agriculture and Fisheries on the subject of the provision of allotments and allotment gardens.

Attention is drawn to the decrease in the number of allotments in urban areas which is mainly due to the demand for land for other purposes, particularly for housing, which makes the retention and acquisition of land for allotments increasingly difficult but the Minister is disposed to think that the difficulties are not always insurmountable and could be overcome by a sympathetic and more effective use of the powers entrusted to local authorities by Parliament.

The Minister suggests that, in considering the provision of land for other purposes of the Council, the local authority should regard such allotment land as the last site to be considered rather than the first and that the provision of land for other purposes, however, important, should not be made at the expense of the allotment movement except as a last resort. **Noted.**

15.—ARCHFIELD ALLOTMENTS—HUTS:

The Borough Surveyor submitted a design for a uniform type of hut for the Archfields Allotments. (E.P. & A.C., 6/3/39—24).

The question of cost has been carefully considered and it has been found necessary to provide for a slight increase over the estimate previously submitted (E.P. & A.C., 16/5/38—22), namely, from £4 to £4 2s. 6d. per hut. It will only be possible to erect huts at the increased price if not less than six are required for any one allotment area.

RESOLVED TO RECOMMEND—

- (1) That the design for single type huts for Archfields Allotments be approved.
- (2) That the question of rent for each hut be referred to the Finance and General Purposes Committee for consideration.

Amendment

Before detailed consideration of the matter, the Finance and General Purposes Committee Recommend—That Recommendation (2) be deleted and the following substituted:—

"That an annual rent of 6/6 per hut be charged."

16.—ALLOTMENTS GENERALLY:

Attention was drawn to the difficulties which have been encountered by local allotment secretaries and by competition judges in identifying the plots.

RESOLVED TO RECOMMEND—That suitable pegs be supplied by the Council for the various Allotments Societies to carry out the required renewal of the numbering of the plots.

[Having considered the matter in its financial bearing, the Finance and General Purposes Committee concur in the proposal.]

Report of the Works and Fire Brigade Committee.

24th April, 1939.

COMMITTEE:

*Councillor A. A. Naar, M.B.E. (*Chairman*).

Aldermen:

B. J. Monro.

*A. J. Reynolds, J.P.,

*F. C. Rice.

Councillors:

F. J. Collins,
*H. Connell, J.P.,
*A. W. Curton,
*A. W. Greville,

*(Mrs.) F. E. Parvin,
*H. G. Potter, J.P., F.S.I.
(*Mayor*),

*J. H. Rodway,
*C. F. Windust.

* denotes Member present.

1.—REQUISITIONS:

The following requisitions were submitted and **approved**:—

	£	s.	d.
Works	1,954	12	11
Fire Brigade	450	15	11

2.—STAFF INCREMENTS:

The Committee have received a report with regard to increments due according to scale to members of the fire brigade staff.

RESOLVED TO RECOMMEND—That such increments be granted as from the appropriate dates, subject in the case of Fireman-Mechanic W. J. Baldwin to his passing an educational examination in accordance with the Council's regulations.

[*Having considered the matter in its financial bearing, the Finance and General Purposes Committee concur in the proposal.*]

3.—STAFF SICKNESS:

A report was submitted with regard to the absence of seven members of the fire brigade staff. **Noted.**

4.—RESIGNATION OF FIREMEN:

The resignations of Fireman F. Sharpe, appointed to the Tottenham Fire Brigade, and Fireman F. H. G. Austin, appointed to the Bexley Heath Fire Brigade, were reported.

RESOLVED TO RECOMMEND—That the arrangements for filling the vacancies be referred to the Chairman (Councillor A. A. Naar, M.B.E.) and the Fire Superintendent, with power to act.

Addendum

Before detailed consideration of the matter, the Finance and General Purposes Committee Recommend that the following be added:—

"(2) That the Fire Superintendent be authorised to issue certificates of approved service under Section 6 of the Fire Brigade Pensions Act, 1925, and the Council consent to the transfers."

5.—TEMPORARY FIREMAN:

The Fire Superintendent reported upon the necessity of appointing four temporary firemen during the holiday period which commences in May.

RESOLVED TO RECOMMEND—That four additional temporary firemen be engaged and that such appointments be referred to the Chairman and the Fire Superintendent, with power to act.

[Having considered the matter in its financial bearing, the Finance and General Purposes Committee concur in the proposal.]

6.—FIRE BRIGADES' UNION:

The Committee have further considered the representation from the Fire Brigades' Union urging consideration of the question of the improvement of service conditions in the brigade (W. & F.B.C., 13/3/39—8), together with a financial report of the Borough Treasurer.

Before reaching any decision on the matter the Committee have directed that an enquiry be made of the members of the brigade as to which system of duty is preferred and that a report hereon, together with a report on the "Stand By" System be submitted to the next meeting.

7.—LONDON PROFESSIONAL FIRE OFFICERS' BOARD:

The Committee gave further consideration to the following recommendation of the above Board (W. & F.B.C., 13/3/39—16), together with a report as to the action of other Authorities in the matter.

"That in consideration of the additional work and responsibilities in connection with the Auxiliary Fire Service in accordance with the Fire Brigade Act, 1938, and the Air Raid Precautions Act, 1937, an increase of salary should be granted to the responsible Officers concerned."

RESOLVED TO RECOMMEND—That subject to the approval of the Home Office an honorarium of £50 be granted to Fire Superintendent R. Cook in respect of his additional duties and responsibilities in connection with the Auxiliary Fire Services of the Borough, such honorarium to cover the period ending 31st May, 1939, and to be subject to adjustment.

Amendment

Before detailed consideration of the matter, the Finance and General Purposes Committee Recommend—

"That the matter be referred back."

8.—LETTER OF APPRECIATION:

The Committee have received and **noted** with satisfaction a letter of appreciation for services rendered by the Brigade at a fire in Devonshire Road, Mill Hill.

9.—FACTORIES ACT, 1937:

Inspections have been carried out under the above Act at the following premises:—

Byron House Laundry Ltd., Granville Road, N.W. 2.

Fractional H.P. Motors Ltd., Rookery Way, N.W. 9.

RESOLVED TO RECOMMEND—That certificates as to means of escape in case of fire be approved in respect of such premises.

10.—GAMEWELL FIRE ALARMS:

It was reported that since the last meeting of the Committee, Gamewell Fire Alarms have been installed in Brookfield Avenue and Pursley Avenue, Mill Hill. **Noted.**

11.—FIRE HYDRANT:

It was reported that a fire hydrant had been fixed in The Orchard, Hampstead Garden Suburb. **Noted.**

12.—INSPECTION OF FIRE APPLIANCES:

A recent inspection of fire appliances in the buildings enumerated in the report of the Chief Officer has been undertaken, when the appliances were found to be in order.

Noted.

13.—FIRE DRILL INSTRUCTION:

Since the last meeting of the Committee (21/3/39) fire drill instruction has been given by the Brigade at the following places:—

John Groom's Crippleage.

Redhill Hospital.

The North Middlesex Gas Company.

Everett, Edgecombe & Company Ltd.

Noted.

14.—NO. 1 TALBOT AMBULANCE:

The Fire Superintendent reported upon the desirability of replacing the No. 1 Talbot Ambulance which has developed engine, steering and braking trouble and which is, at the present time undergoing overhaul and repair. (Mayor's Easter Recess Report, 14/4/39—Item 18).

The ambulance was purchased in November, 1934, and upon completion of repairs would be suitable for the training of the A.R.P. ambulance service.

RESOLVED TO RECOMMEND—

- (1) **That an advertisement be issued inviting tenders for the supply of a new ambulance.**
- (2) **That upon delivery of the new ambulance the No. 1 Talbot Ambulance be transferred to the A.R.P. ambulance service for training purposes, subject to the approval of the Middlesex County Council.**

[Having considered the matter in its financial bearing, the Finance and General Purposes Committee concur in the proposal.]

15.—FIRE AND AMBULANCE CALLS:

The following is a statement of fire and ambulance calls received during the month of March.

Fire Calls.		Ambulance Calls.	
Fire Calls	20	Private	146
False Alarms with good intent	2	Private for Finchley	1
Malicious False Alarms	5	Private for Wembley	1
Inspection	1	Accidents	81
		Not required, etc.	10
		Private by Finchley for Hendon	1
		Malicious False Alarms	1
	28		241
		Fatal Cases 3.	Noted.

16.—FIRE BRIGADE OPEN DAY:

It was reported that Saturday the 20th May had been fixed for the Central and Mill Hill Fire Stations to be open for the inspection of the public.

The Committee are of the opinion that only adults should be admitted to the stations and instructions have been given for the necessary arrangements to be made for drawing the attention of the public to the open day.

17.—NORTH MIDDLESEX GAS COMPANY'S WORKS:

In connection with a potential fire risk at the North Middlesex Gas Company's Works which had been the subject of correspondence with the Home Office, it was reported that a fire post is being provided near the gas works to cover this area. **Noted.**

18.—FISH FRYING:

A letter was submitted from the Minister of Health stating that Section 108 of the Public Health Act, 1936, enables byelaws to be made with respect to the trade or business of fish frying in order to prevent any noxious or injurious effects of the trade or business, but the section is not wide enough to allow additions to the model byelaws for the purposes the Council have in mind (W. & F.B.C., 13/2/39—17), i.e., the prevention of fire due to spontaneous combustion of the residue from cooking. **Noted.**

19.—TRADE REFUSE:

The Committee gave further consideration to the question of the collection of trade refuse in the light of the reference from the Council (27/3/39) and after very careful examination of the question they see no reason to depart from their previous recommendation in the matter. (W. & F.B.C., 13/3/39—22).

Accordingly the recommendation is repeated in the following terms:—

That no variation be made to the existing arrangements approved by the following resolutions of the Council of the 20th June last:—

- (1) **That under powers conferred by Section 73 of the Public Health Act, 1936, the Council undertake the weekly removal of trade refuse upon request of the occupier of any premises within the Borough.**
- (2) **That one standard bin be collected free of charge and that the following charges (payable in advance) be made for the remaining bins:—**

	£	s.	d.	
Second Bin	1	4	0	per annum
Additional Bins	18	0		each per annum
				} payable by two half-yearly instalments.

20.—INDOOR SWIMMING BATH:

The Committee received a resolution of the Education Committee, together with a letter from Mr. H. Williams of 21, Bertram Road, urging upon the Council the necessity of the provision of an indoor swimming bath to provide the necessary facilities for swimming instruction all the year round.

The Committee already have this matter under consideration. (W. & F.B.C., 13/3/39—17).

RESOLVED—That the Education Committee and Mr. H. Williams be informed accordingly.

21.—OPENING OF SWIMMING POOLS:

The Borough Surveyor reported that the necessary repairs and fitting up of the swimming pools at Mill Hill and West Hendon was nearly completed and suggested that the pools be opened for the forthcoming season on Saturday, the 29th April.

RESOLVED TO RECOMMEND—That Mill Hill and West Hendon Swimming Pools be opened on Saturday the 29th April.

TOWN HALL.**22.—PROVISION OF WIRELESS:**

The Borough Surveyor reported upon the question of the provision of a wireless set in the Town Hall for use in an emergency at an estimated cost of £25.

RESOLVED TO RECOMMEND—That no action be taken in the matter at present.

23.—PUBLIC TELEPHONE KIOSK:

Pursuant to instructions (W. & F.B.C., 13/2/39—16) the Borough Surveyor reported that the inclusive rental for two exchange lines with multi coin boxes would be £4 6s. 0d. per quarter with a connection charge not exceeding 15/-. The minimum term for the agreement would be one year.

The annual rental for the two cabinets would be £7 8s. 0d., or alternatively they can be purchased for £11 15s. 0d. each.

RESOLVED TO RECOMMEND—That two public telephones be installed in the Town Hall and that the cabinets be purchased at a cost of £23 10s. 0d.

Amendment

Before detailed consideration of the matter, the Finance and General Purposes Committee Recommend—That the matter be referred back for reconsideration and for further report by the Borough Surveyor on the lines indicated.

24.—SEWER, NORTH CIRCULAR ROAD:

A letter was submitted from the Grand Union Canal Company in connection with the construction of the new sewer in the North Circular Road to the cost of which the Company are contributing £2,500. (W. & F.B.C., 21/11/38—32). The Company suggest they should enter into a formal agreement to pay 50 per cent. of the agreed contribution on production of a certificate to the effect that half the work has been completed, the balance to be paid on completion.

RESOLVED TO RECOMMEND—That an agreement be entered into with the Grand Union Canal Company on the lines indicated.

[Having considered the matter in its financial bearing, the Finance and General Purposes Committee concur in the proposal.]

25.—SURFACE WATER SEWER, EDGWARE ROAD:

A letter was received from the Grand Union Canal Company asking the Council to take over two sections of surface water sewers in Edgware Road. (W. & F.B.C., 21/11/38—31).

The first section is on the north side of the Silk Stream Bridge near the west boundary of the Edgware Road and extends northwards for a distance of approximately 120 yards.

The second section discharges into the River Brent and extends northwards on the westerly side of the Edgware Road for a distance of approximately 117 yards.

These pipes have been laid as a consequence of tipping operations on the land adjacent to the Edgware Road and are intended to deal with the surface water drainage from the road.

RESOLVED TO RECOMMEND—That in view of the application of the Grand Union Canal Company the Council declare that as from the date of the completion of the sewers to the satisfaction of the Borough Engineer and Surveyor, viz.:—

5th January, 1939—River Brent Section,
22nd February, 1939—Silk Stream Section;

the said sewers become vested in the Corporation in pursuance of Section 17 of
the Public Health Act, 1936.

[Having considered the matter in its financial bearing, the Finance and General Purposes
Committee concur in the proposal.]

26.—STATION ROAD AND HALE LANE SEWER:

The Borough Surveyor reported that the various sections of the Edgware Relief
Sewers scheme have been completed and that the only outstanding work is the permanent
reinstatement of the road in The Grove and the adjacent section of Hale Lane. It is
anticipated that this work will be completed in about a week. **Noted.**

27.—REPAIRS TO PROPERTIES:

It was reported that 123 requisitions have been dealt with since the last meeting.

Noted.

ireless set
t present.

reported
£4 6s. 0d.
n for the

they can

d in the

Purposes
sideration
ated.

on with
hich the
suggest
tribution
ted, the

e Grand

ncil to
/11/38

west
nately

on the

adja-
inage

Grand
etion
z:—

Report of the Libraries and Local Pensions Committee.

24th April, 1939.

COMMITTEE:

*Councillor P. Lightfoot (*Chairman*).

Aldermen:

*W. M. Maughan, J.P.,

*R. A. B. Teare, M.B.E.

Councillors:

E. J. Cox,
*F. W. Gilpin,
*C. Pinkney,

*C. J. Pryke, F.I.A.C.,
A.M.I.S.E.,

*T. J. Scott,
(Mrs.) M. Thomas.

*C. R. Richardson,

* denotes Member present.

Part I.—Old Age Pensions.

1.—CLAIMS, ETC.:

The Committee considered seven claims (1 adjourned) and one question. The details of each case and the Committee's decision thereon are recorded in the Local Pension Minute Book.

2.—INCREASED RATE OF PENSION:

It was decided to support resolutions from the City of Bradford and the Borough of Slough on the above subject.

Part II.—Libraries.

3.—REQUISITIONS:

Requisitions amounting to £543 16s. 1d. were submitted and **approved**.

4.—BOOK SELECTION SUB-COMMITTEE:

The following report was submitted:—

24th April, 1939.

SUB-COMMITTEE:

*Councillor P. Lightfoot (*Chairman*).

Alderman:

*R. A. B. Teare, M.B.E.

Councillors:

(Mrs.) M. Thomas, *C. R. Richardson, *T. J. Scott.

* denotes Member present.

PURCHASE OF BOOKS—ADDITIONS TO STOCK:

The Sub-Committee considered lists comprising 165 recent and standard books suggested for addition to the stock at the Central Library at an estimated cost of £52, 177 volumes for addition to the stock of the Golders Green Branch Library at an estimated cost of £50, and 142 volumes at an estimated cost of £43 for addition to the stock at the Mill Hill Branch Library.

The Sub-Committee

RECOMMEND—That the Chief Librarian be authorised to purchase the books included in the lists submitted.

RESOLVED TO RECOMMEND—That the report of the Sub-Committee be approved and adopted.

5.—STATISTICS:

The Chief Librarian submitted his statistical statement for the preceding month, details of which appear in the appendix to the report of the Finance and General Purposes Committee.

LECTURES.

6.—MILL HILL BRANCH LIBRARY:

A report on the attendances at the lectures to adults at the above Library during the past season was received from the Chief Librarian.

RESOLVED TO RECOMMEND—That arrangements be made for the continuance of the lectures during 1939/40.

7.—UNIVERSITY EXTENSION:

It was reported that the total attendance for the course of ten lectures given last term by Murdo Mackenzie, M.D., B.S., M.R.C.P., on "Conflicts of Temperament" was 162. **Noted.**

8.—CHILDREN'S LIBRARIAN:

The Chief Librarian reported that Miss E. H. Colwell had again been invited to give an advanced course of eight lectures on Library work with children during April and May at the School of Librarianship (University College).

RESOLVED — That the congratulations of the Committee be accorded to Miss Colwell.

9.—BRANCH LIBRARY—BURNT OAK:

The Borough Surveyor reported that in company with the Chief Librarian he had recently attended a meeting with representatives of the Middlesex County Council and the Watling Association with regard to a site for a Branch Library at Burnt Oak.

The original proposal was for the acquisition of an area of land adjacent to the Watling Community Centre and fronting Orange Hill Road. (Li.C., 22/11/37—24). A plan of an alternative site, viz., with a frontage of approximately 80 feet to Deansbrook Lane and a depth of 120 feet was submitted.

It has been explained to the Association's Architect that it is the Council's intention that the proposed Library should be erected as a separate entity, and arrangements have been made to forward an outline plan of the suggested library premises.

RESOLVED TO RECOMMEND—That the alternative site fronting Deansbrook Lane be approved, and that the Borough Surveyor continue his negotiations with the Watling Association.

Report of the Housing Committee.

24th April, 1939.

COMMITTEE:

*Councillor F. W. Gilpin (*Chairman*).

Aldermen:

*W. M. Maughan, J.P.,

*R. A. B. Teare, M.B.E.

Councillors:

E. J. Cox,
*P. Lightfoot,
*C. Pinkney,

*G. J. Pryke, F.I.A.C.,
A.M.I.S.E.,
*C. R. Richardson,

*T. J. Scott,
(Mrs.) M. Thomas.

* denotes Member present.

TENANCIES.

1.—TRANSFERS (APPLICATIONS):

The Housing Manager reported the following applications:—

Application

No.

5295 From a 3-bedroom type house at Brent Hill to a larger type in the same district.

4154 From a 3-bedroom type house at Clitterhouse to a parlour type at Brent Hill.

5021a From a 2-bedroom to a 3-bedroom type at Clitterhouse.

RESOLVED—That the applications be approved and transfers effected when suitable accommodation is available.

2.—TRANSFERS (ARRANGED):

The Housing Manager reported that transfers had been arranged as follows:—

Appln.

No.

Name.

From.

To.

6410 Poole, E. 57, Dole Street 85, Goldsmith Avenue.

4637 Parker, A. 46, Hyde Crescent 44, Hyde Crescent.

2478 Gates, A. 44, Goldsmith Avenue 46, Hyde Crescent.

Noted.

Tenant No. 4023, being now deceased, the Housing Manager reported with regard to a transfer of the tenancy.

RESOLVED TO RECOMMEND—That the report be approved.

LODGERS.

3.—TENANT NO. 3339:

A request was received from the above Tenant for permission to house permanently a person who had been residing at the premises as a temporary measure.

RESOLVED TO RECOMMEND—That the request be not granted, and that the person concerned be required to leave the flat within a period of fourteen days.

4.—TENANT NO. 218:

The above Tenant, who is a Widow, asks permission for her son, his wife and child, aged four years, to reside with her.

RESOLVED TO RECOMMEND—That the application be granted subject to the Tenant agreeing to remove to a 3-bedroom type house when available.

5.—TENANT NO. 6366:

The Tenant in this case is at present in Hospital, and application has been made by his wife for a relative to reside with her temporarily.

RESOLVED TO RECOMMEND—That the request be granted for a period of two months.

6.—ARREARS OF RENT:

The following tenants were reported to be four weeks or more in arrear:—

4779	D.4	2809	3893
4148	2536	4311	5565
5392	6272	5119	5358

With regard to the under-mentioned the position is as follows:—

4779 Tenant making an effort to maintain current rent despite unemployment. An application has been received for transfer to a cheaper house which will be arranged when a suitable vacancy occurs.

D.4 Payment of rent maintained, and a promise made to pay 2/- weekly off arrears.

2536 } Reported last meeting. Tenants now in work—Payment of rent and a
5358 } sum off arrears being made.

4311 } Tenants unemployed—A sum being paid off arrears.
5565 }

5119 Reported at last meeting, payment of rent maintained and a sum paid weekly off arrears.

RESOLVED TO RECOMMEND—

- (1) **That a further report be submitted with regard to Tenants Nos. 4148, 6272, 2809 and 3893.**
- (2) **That Tenant No. 5392 be required to pay 5/- weekly off the arrears, failing which he be served with a notice to quit.**

HOUSING APPLICATIONS.

7.—REVISED LIST:

The Housing Sub-Committee, having completed the revision of the list of applicants for Council Houses, a new list was circulated to the Members of the Housing Committee. The following is a summary of such list:—

Urgent A.1	233
Urgent A	4
Urgent B	39
Urgent C	22
List 1	156
List 2	116
								570

Noted.

8.—NEW APPLICATIONS:

A list of new applications was reported and the following is a summary thereof:—

Urgent A.1	9
Urgent C	2
List 1	9
List 2	4
									24
									—

Noted.

OVERCROWDING.

9.—PRIVATELY OWNED HOUSES:

At the last meeting seven outstanding cases were reported. Of this number one is no longer overcrowded and the offer of a Council House has not been accepted in another case which has been referred to the Public Health Department. In connection with the remaining five, two have refused offers of Council tenancies. **Noted.**

10.—HENDON COUNCIL ESTATES:

The annual survey of tenancies is being carried out and when completed a report will be submitted showing the position at the 30th April. **Noted.**

11.—WATLING ESTATE:

The following particulars were furnished:—

Total number of applications received	27
Overcrowding abated by transfer to the Dole Street Estate	17
Overcrowding abated by transfer to Reets Farm Estate	1
Overcrowding already abated	5
Application withdrawn	1
									—
									24
									—
Outstanding applications	3
									—

Offer of Council house declined in one case and further consideration has been deferred. **Noted.**

12.—APPOINTMENT OF GENERAL FOREMAN:

The Committee considered a Schedule of applications.

RESOLVED—That the undermentioned be interviewed by the Committee at their meeting on the 22nd May:—

- Mr. H. M. Heard, Hendon.
- Mr. E. W. Rhodes, Crouch End.
- Mr. A. Bennett, Bury.
- Mr. W. J. H. Mears, Shepherds Bush.
- Mr. F. C. Wood, Mitcham.
- Mr. R. H. Faulkes, Stanmore.
- Mr. J. H. Steeples, Buxton.
- Mr. H. Lees, Hyde, Cheshire.
- Mr. J. W. Cooper, Finchley.

13.—BRENT HILL HOUSING SCHEME—120 HOUSES:

Pursuant to Committee's instructions (14/2/38—13) the Borough Surveyor submitted plans and estimates in connection with the proposed development of 120 houses on the surplus (Sewage Disposal) Land—north of the River Brent.

In preparing the lay-out plan due regard has been paid to the desirability of a small shopping centre at the Dallas Road end of the estate to meet what is regarded as a definite need, and the linking up at some future date of the new estate roads with Brent Park Road, which will have the effect of improving the general planning of this area.

As regards the design of the houses, the plans submitted show 60 houses of the two-bedroom type and 60 of the three-bedroom type, which is in accordance with the original decision, but on review the Committee are of opinion that in view of recent experience and the apparent demand for two-bedroom type houses a re-allocation is desirable and the following estimates are based upon 90—two-bedroom, and 30—three-bedroom type houses.

Houses:—

	£	s.	d.
90 2-bedroom type houses at £390 each	35100	0	0
30 3-bedroom type houses at £451 each	13530	0	0
	48630	0	0
Clerk of Works' salary, Printing, Advertising, etc.	450	0	0
Cost of raising loan, etc.	490	0	0
	£49,570	0	0

Roads:—

Estimated cost of Roads	6452	1	3
Add 5 per cent. contingencies	322	18	9
	6775	0	0
Clerk of Works' salary, Cost of raising loan, etc.	225	0	0
	£7000	0	0

Sewers:—

Estimated cost of sewers, manholes and connections	2932	0	0
Add 5 per cent. contingencies	146	0	0
	3078	0	0
Clerk of Works' salary, cost of raising loan, etc.	122	0	0
	£3200	0	0

The Council, on the 5th December, 1938 (F. & G.P.C., 28/11/38—4), approved the allocation of 10 acres of land but the above scheme will now necessitate an increase in this area.

RESOLVED TO RECOMMEND—

- (1) **That the suggested allocation, viz.: 90 houses of the 2-bedroom type and 30 of the 3-bedroom type be approved and that any previous resolution of the Council inconsistent herewith be varied accordingly.**

- (2) That the estimates as set out above be approved, and application made to the Minister of Health for the following loan sanctions:—

Houses	£49,570	For a period not exceeding 60 years.
Roads	£7,000	For a period not exceeding 20 years.
Sewers	£3,200	For a period not exceeding 30 years.

- (3) That an application be now submitted to the Minister of Health for consent to the appropriation, from sewage disposal, of 12.6 acres to housing and that any resolutions of the Council inconsistent herewith be varied accordingly.
- (4) That upon receipt of the Minister's instrument of appropriation the allotment tenancies on 12.6 acres Brent Hill Temporary Allotments be determined by re-entry on three months' notice in writing to expire on a date to be fixed by the Housing Committee in relation to their building programme.
- (5) That recommendations (3) and (4) above be regarded as matters of urgency and reported for information to the Estates, Parks and Allotments Committee.

Amendment

Before detailed consideration of the motion, the Finance and General Purposes Committee Recommend—That Recommendation No. 2 be deleted and the following substituted:—That the plans and estimates be approved and submitted to the Minister of Health with an application for a subsidy under the Housing (Financial Provisions) Act, 1938, and for consent to the borrowing of the following loans:—

<i>Houses,</i>	<i>£49,570.</i>	<i>For a period not exceeding 60 years.</i>
<i>Roads,</i>	<i>£7,000.</i>	<i>For a period not exceeding 20 years.</i>
<i>Sewers,</i>	<i>£3,200.</i>	<i>For a period not exceeding 30 years.</i>

14.—HOUSES—OLD AGE PENSIONERS:

A communication was submitted from Mrs. F. Dawson asking the Council to provide housing accommodation for Old Age Pensioners. The matter has been referred to the Borough Surveyor for report.

Report of the Buildings and Town Planning Committee.

24th April, 1939.

COMMITTEE:

*Councillor G. H. Hignett (*Chairman*).

Aldermen:

*W. R. Clemens, F.C.A.,
*J. J. Copestake, J.P.,

S. H. Egan, J.P.
(*Deputy Mayor*),

*B. Flowers.

Councillors:

*E. Arter, M.C., M.I.A.E.,
*F. H. Bate,
*J. Griffiths,

*W. A. Hicks,
*L. Hirshfield,
*T. Pugh,

*W. H. N. Shakespeare,
M.C., A.F.C., J.P.,
*H. P. Small.

• denotes Member present.

HENDON PLANNING SCHEME NO. 1.

1.—8, BITTACY HILL, MILL HILL:

An application was considered from Huntleys (Mill Hill) Ltd., together with a report by the Borough Surveyor thereon, for consent to use the above shop premises for the purpose of a fish frying business. The premises front Holders Hill Circus and back on to residential property in Abercorn Close. There is already an existing fried fish shop in Sanders Lane, situate within a distance of half-a-mile.

The Council (B. & T.P.C., 26/9/38—9) have previously refused consent in respect of a similar application in connection with 15, Bittacy Hill.

The application has been advertised in compliance with Clause 30 of the Hendon Planning Scheme No. 1 and 25 objections from residents in the vicinity have been received.

RESOLVED—That consent be refused (Clause 28).

2.—GARAGES— KING'S CLOSE, HENDON:

The Borough Surveyor reported on a further application from Messrs. Hanchett, Copley & Hails for consent to use certain existing single storey buildings situate between residential property for the purpose of a general business garage. The Council (9/11/38—Recess Report—24 (C)) previously refused a similar application from the applicants, and it is understood that the new application is made to enable the applicant to lodge an appeal within the prescribed time, which he allowed to elapse on the previous occasion.

The application has been advertised in accordance with the provisions of Clause 30 of the Hendon Planning Scheme No. 1 and 16 objections, including a Building Society, who are interested in a number of properties in the neighbourhood, have been received. (B. & T.P.C., 16/1/39—12).

RESOLVED—That consent be refused (Clause 28).

3.—LAND—OFF HOLDERS HILL ROAD, HENDON:

The Borough Surveyor reported on an application from Messrs. Edwin, Evans & Sons for consent to the construction of new road to be called "Hamilton Road," commencing at Holders Hill Circus and finishing at Dollis Road opposite Thornfield Avenue. The construction of another road with an entrance to this Circus is undesirable from a traffic point of view, and the Committee

RESOLVED—

- (i) That consent be refused (Clauses 38 and 39).
- (ii) That the application be disapproved under the Restriction of Ribbon Development Act, 1935.

4.—57, SELVAGE LANE, MILL HILL:

The Borough Surveyor reported to the effect that as a result of a complaint received regarding the use of the above premises for business purposes, inspections had been made, and it was found that the garage attached to the house was used as a workshop in connection with the business of a plumber in contravention of the Hendon Planning Scheme No. 1.

The occupier's attention has been called to the matter, and he has offered to discontinue the business use of the premises by the end of July next. In these circumstances the Committee

RESOLVED TO RECOMMEND—That, provided the occupier gives an undertaking in writing to discontinue the present business use of the premises by the end of July, 1939, no further action be taken in the matter.

5.—161, HALE DRIVE, MILL HILL:

Arising out of a complaint received from the Mill Hill Ratepayers' and Residents' Association regarding the use of the above premises in connection with a newspaper delivery business, the Borough Surveyor reported that investigations had been made and it would appear that the temporary building approved under the Hendon Planning Scheme No. 1 (Consent No. 225) for use as a private garage, is now utilised for business purposes in contravention of the provisions of the Scheme.

RESOLVED TO RECOMMEND—That the occupier's attention be called to the non-compliance with the terms of the consent issued under the Scheme.

6.—10, PARKSIDE, MILL HILL:

It was reported that the above premises had been converted into two flats after the plans for such conversion had been disapproved by the Council. The property is situate within a special residential zone of the Hendon Planning Scheme No. 1 and it is undesirable for such conversions to be undertaken.

RESOLVED TO RECOMMEND—That the matter be referred to the Town Clerk to take the necessary action in respect of the contravention of the Hendon Planning Scheme No. 1 and for Building Bylaws.

7.—LAND—GREAT NORTH WAY, HENDON:

The Borough Surveyor reported on a letter from Mr. J. Hinge regarding an area of approximately $5\frac{1}{2}$ acres of land situate on the north side of Great North Way adjacent to Copthall Playing Fields, and scheduled in the Hendon Planning Scheme No. 1 as a proposed public open space. It is suggested by Mr. Hinge that under Clause 6 of the Scheme, the Council should release the land for building purposes. Having regard to the situation of the land it is undesirable for such land to be released, and as it has not been found possible to agree the price to be paid for the purchase of the land, the Committee

RESOLVED TO RECOMMEND—

- (i) That in view of the inability of the Council to purchase by agreement the Council pursuant to powers vested in them by Section 25 of the Town and Country Planning Act, 1932, make an Order for the compulsory acquisition of the land approximately ~~5~~^{5.19} acres in extent situate on the north side of Great North Way, adjacent to Copthall Playing Fields.

- (ii) That the Corporate Seal be affixed to the Plan and Order, both documents being identified by the title "~~Borough of Hendon (Land—North Side Great North Way)~~ Compulsory Purchase Order, 1939."
- (iii) That the Order be published in the manner prescribed by Part I. of the Third Schedule to the Town and Country Planning Act, 1932.
- (iv) That the Order be submitted in due course for the confirmation of the Minister of Health.

[Having considered the matter in its financial bearing, the Finance and General Purposes Committee concur in the proposal.]

8.—LAND—OAKHAMPTON ROAD, MILL HILL:

In connection with the approval of Building Application No. A.7357 (B. & T.P.C., 11/4/38) relating to the extension of Oakhampton Road, the Council authorised the service of a Notice on the Owners under Section 262 of the Public Health Act, 1936, requiring the water course on the southern boundary of the land to be culverted. Mrs. E. M. Davies, the owner, has always denied liability and proceedings have taken place in the Police Court. There is at present, a writ outstanding in connection with High Court Proceedings. The Borough Surveyor has, however, had a meeting with the representatives of the owners and it is suggested that the matter be now settled on the following terms:—

- (1) That Mrs. Davies should pay the sum of £550 to the Council forthwith.
- (2) That in consideration of such payment, the Council will withdraw and cancel the Charge registered at the Local Land Registry, and will withdraw the notice to pipe the watercourse, which was served under the relevant section of the Public Health Act, 1936.
- (3) That the Council will undertake at public expense the piping of the ditch.
- (4) That Mrs. Davies will transfer to the Corporation free of all cost to the Council, the land required for the widening of Ashley Lane, and will also form an opening from the existing new road (extension of Oakhampton Road) into Ashley Lane, at the same time as the Contractors are completing the new road, such opening to be of a temporary and inexpensive nature.
- (5) That in the conveyance of the land in Ashley Lane to the Corporation, the Council shall undertake all present and future liability as regards road charges in connection with the making up and widening of Ashley Lane, and will indemnify Mrs. Davies in respect of any such liabilities, in respect of the land to be conveyed under paragraph (4).

RESOLVED TO RECOMMEND—That Mrs. E. M. Davies be informed that the Council are prepared to settle the matter on the terms above indicated.

[Having considered the matter in its financial bearing, the Finance and General Purposes Committee concur in the proposal.]

9.—MIDDLESEX COUNTY COUNCIL (GENERAL POWERS) ACT, 1938:

The Committee considered in relation to the Hendon Planning Schemes the question of storage of food and sale from certain premises registered under the above Act, particulars of such premises being referred from the Public Health and Medical Services Committee (6/3/39—16).

RESOLVED—That the Borough Surveyor be instructed to submit a report on the matter to the next meeting.

10.—BUILDING APPLICATIONS:

(A) The following applications were in order on submission and have been accordingly approved as indicated:—

Apph. No.	Description and Situation.	Public Health Act, 1936.	Town Planning.	Restriction of Ribbon Development Act, 1935.
A.8005	Air raid shelters, north side, Somerton Road, N.W.2. Owner and Applicant—Handley Page Ltd.	Approved	—	—
A.8013	Air raid shelter, 9, Constable Close, N.W.11. Owner—B. W. Fagan. Applicant—Anti Bomb Constructions Ltd.	Approved	—	—
A.8016	Garage, plot 13, Broadfields Avenue, Edgware. Owner and Applicant—H. J. Hook & Son	Approved	—	—
A.8018	2 air raid shelters, Middlesex Hospital Laundry, Colindale Avenue, N.W.9. Owner and Applicant—F. Davison	Approved	—	—
A.8021	Bungalow and garage, east side, Burtonhole Lane, N.W.7. Owner—G. S. Dibb. Applicant—Wates Ltd.	Approved	Consent given (Clause 5) Condition:— That the land required for widening Burtonhole Lane shall be conveyed to the Corporation for highway purposes	—
A.8022	Hall, north side, Manor Park Crescent, Edgware. Owner—London Congregational Union. Applicant—J. P. Blake	Approved	Consent given (Clause 28) Condition:— That the portion of the site not built on shall be maintained in good condition to the satisfaction of the Council	—
A.8023	New art block, King Alfred School, North End Road, N.W.11. Owner—King Alfred School Society. Applicant—Eugen C. Kaufmann	Approved	Approved (Scheme 2) Interim Development Order:— That the work shall be actively commenced within twelve months of the date of this Order	Approved.

Appl. No.	Description and Situation.	Public Health Act, 1936.	Town Planning.	Restriction of Ribbon Development Act, 1935.
A.8028	Garage, 42, St. John's Road, N.W.11. Applicant—A. L. H. Moore	Approved	Approved (Scheme 2) Interim Development Order.— (i) That the proportion of site which may be covered by buildings shall not exceed 37 per cent. (ii) That the distance between the north and east walls of the garage and the owner's north and east boundaries shall not be less than one foot (iii) That the building shall only be used for garaging private cars (iv) That the work shall be actively commenced within twelve months of the date of this Order	—
A.8030	Addition, 2, Edgwarebury Gardens, Edgware. Owner—A. E. Spurrier. Applicant—A. H. W. Todman and Son	Approved	—	—
A.8031	Addition to sports pavilion, south side, Bunnas Lane, N.W.7. Owner—Mill Hill Sports Ltd. Applicant—J. Childs & Son Ltd.	Approved	—	—
A.8032	Cloakroom, 87, Marsh Lane, N.W.7. Owner and Applicant—J. P. Davis	Approved	—	—
A.8034	Room over garage, "Links Side," Courtlands Avenue, N.W.7. Owner and Applicant—W. F. Thorpe	Approved	Consent given (Clause 43 (3)) Condition:— That the east wall of the addition may be erected up to the owner's east boundary	—
A.8035	Addition, 28, Clovelly Avenue, N.W.9. Owner and Applicant—T. F. H. Thorne	Approved	—	—

Appl. No.	Description and Situation.	Public Health Act, 1936.	Town Planning.	Restriction of Ribbon Development Act, 1935.
A.8037	Air raid shelter, 169, Station Road, Edgware. Owner—M. E. Mitzman. Applicant—Oram (Builders) Ltd.	Approved	—	—
A.8038	Garage, plot 16, Broadfields Avenue, Edgware. Owner and Applicant—H. J. Hook & Son	Approved	—	—
A.8039	Additions and new garage, "Far End," Wyldes Close, N.W. 11. Owner and Applicant—C. E. Simmons	Approved	—	—
A.8040	Garage, 28, Clovelly Avenue, N.W. 9. Owner and Applicant—T. F. H. Thorne	Approved	Consent given (Clause 42 (ii)) Condition:— That the proportion of site which may be covered by buildings shall not exceed 34 per cent.	—
A.8042	Addition, 2, Allington Road, N.W. 4. Owner—S. Jacobs. Applicant—W. Richards & Sons (Hendon) Ltd.	Approved	—	—
A.8043	Bay window, 11, St. Margaret's Road, Edgware. Owner—Rev. R. C. Thomas. Applicant—W. E. Pearce and Son	Approved	—	—
A.7738a	Amended plan of additions to 89, Platts Lane, N.W. 3. Owner and Applicant—J. McFarlane	Approved	Consent given (Clauses 42 (ii) and 43 (3)) Conditions:— (i) That the proportion of site which may be covered by buildings shall not exceed 34 per cent. (ii) That the west wall of the addition may be erected up to the owner's west boundary and that the distance between the west wall of the addition and the east wall of No. 87 shall not be less than 2 feet 6 inches (iii) That Consent No. 420 is hereby cancelled	—

Appl. No.	Description and Situation.	Public Health Act, 1936.	Town Planning.	Restriction of Ribbon Development Act, 1935.
A.8009	10 houses, Nos. 44-54 and 45-51, Worcester Crescent, N.W.7. Owner and Applicant—G. Wimpey & Co. Ltd	Approved	Consent given (Clause 43 (3)) Condition:— That the distance between the south-west wall of house No. 48 and the owner's south-west boundary shall not be less than three feet, and that the distance between the north-east wall of house No. 50 and the owner's north-east boundary shall not be less than three feet	—
A.8014	Garage, north-east side, Edgware Road, N.W.2. Owner and Applicant—Shell-Mex & B.P. Ltd.	Approved	—	Deferred.
A.8015	Garage, Highfield Court, Highfield Road, N.W.11. Owner—S. N. & A. Mackover. Applicant—R. A. Cabel	Approved	—	—
A.8024	Alterations, 5, The Park, N.W.11. Owner—Mrs. K. Mannheim. Applicant—M. R. Hofer	Approved	Approved (Scheme 2) Interim Development Order:— That the work shall be actively commenced within twelve months of the date of this Order	Approved.
A.7987	New Sacristy, St. Vincent's Priory, The Ridgeway, N.W.7. Applicant—Emden Egan & Co.	Approved	Consent given (Clause 28)	Approved.
A.7945	Conversion of Electric Cinema into 3 shops, Cricklewood Broadway, N.W.2. Owner—The House Property and Investment Co. Ltd Applicant—John P. Briggs	Approval already given	Approval already given	Approved.

(B).

Applications Considered.

The following applications required special consideration and the Committee's decision is given in each case hereunder:—

A.7210	Conversion of "Kimberley," Tennyson Road, Mill Hill, into four flats. Owner and Applicant—R. D. Carr	Approved	Consent given (Clauses 28, 35, 36, 43, 60) Conditions:— (i) That the distance between the west wall of the building and the east wall of the adjoining building shall not be less than seven feet (ii) That the owner shall enter into an agreement limiting the number of tenancies to 4 and prohibiting sub-letting
A.7967	Alterations and addition, 12, Millway, N.W. 7. Owner—Mrs. Peake. Applicant—W. F. Thorpo	Approval already given	Consent given (Clause 26) Condition:— That the building shall only be used as a dwelling-house for use by a single family
A.7969	Lay-out of new streets and construction of private sewers in connection therewith, Bittacy House Estate, south side, The Ridgeway, N.W. 7. Owner and Applicant—Comben & Waking Ltd.	Approved	Conditions:— (i) That the footpath at present passing through the Estate shall be diverted by means of a Magistrate's Order at the expense of the applicants (ii) That the applicants shall enter into an agreement with the Council in a form to be approved by the Town Clerk for dealing with the sewers passing through the property known as 32, Engel Park

ing with the sewers
passing through the
property known as 32,
Engel Park

Appln.
No.

Description and Situation.

Public Health Act, 1936.

Town Planning.

Restriction of Ribbon
Development Act, 1935.

(iii) That the applicants shall enter into an agreement to make such alterations to the soil and surface water sewers in Engel Park as may be necessary to provide, in the opinion of the Council, an adequate outlet for the drainage of the Estate

A.7992 2 houses and garages, plots 5 and 6, Hendon Wood Lane, N.W.7. Owner and Applicant—Aubrey Bell Ltd.

Approved

Consent given (Clause 43 (3))
Condition:—
That the south-east wall of the garage on Plot 6 may be erected up to the owner's south-east boundary

Approved.
Conditions (subject to the approval of the Middlesex County Council):—

- (1) That the owner will dedicate the land required to form the second carriage-way along this length of Hendon Wood Lane
- (2) That the owner will lay out the second roadway to have a twenty feet carriageway and a ten feet footpath with suitable connections at each end to the existing road in accordance with plans and sections contained in Application No. A.6112
- (3) That this consent shall become void so far as it is applicable to the erection of buildings unless within three years from the date hereof the construction of such buildings has been substantially commenced.

Appl. No.	Description and Situation.	Public Health Act, 1936.	Town Planning.	Restriction of Ribbon Development Act, 1935.
A.8019	Demolition of Ionic Theatre and erection of new Cinema, east side, Finchley Road, N.W. 11 Theatres Ltd. Applicant—W. J. King	Approved	Approved (Scheme 2) Interim Development Order:— (i) That the colour of the roofing material to be used shall be to the approval of the Council (ii) That the work shall be actively commenced within twelve month of the date of this Order	Approved (Section 17 and Section 2). Condition:— That detail plans of the proposed draw-in shall be submitted to the Council for their approval and that adequate footpath accommodation shall be provided for the use of the public.
A.8029	Garage, 43, Greenfield Gardens, N.W. 2. Rosekilly. Applicant—S. J. Cook	Disapproved (Public Health (Buildings in Streets) Act, 1888)	—	—
A.8033	Store shop, west side, Holders Hill Road, N.W. 7. Owner and Applicant—North Middlesex Gas Co.	Approved	Deferred, pending advertisement under Clause 30	Deferred.
A.8036	Addition, 9, Glendor Gardens, N.W. 7. Britton. Applicant—W. F. Thorpe	Disapproved (By-law 59, Section 85, Hendon Urban District Council Act, 1929)	Consent refused (Clause 28)	—
A.8041	Garage, 22, Broadhurst Avenue, Edgware. A. G. F. Cartwright. Applicant—W. E. Pearce and Son	Disapproved (Public Health (Buildings in Streets) Act, 1888)	—	—

11.—TEMPORARY BUILDINGS:

The following applications for temporary buildings were in order on submission, and the Committee RECOMMEND—That such applications be approved for a period expiring on the 31st March, 1942:—

A.7837	Garage, 36, Montrose Avenue, Burnt Oak. Applicant—R. A. Green	Owner and Applicant	Approved	—
--------	--	---------------------	----------	---

Appl. No. A.7870

Description and Situation. Storage shed, east side, Edgware Road, N.W. 2. Owner and Applicant—L. Bell

Public Health Act, 1936. Approved

Town Planning. --

Restriction of Ribbon Development Act, 1935. Approved.

Conditions:--

- (1) That the proposed building shall be temporary
- (2) That if and when required by the Minister of Transport and/or the Hendon Borough Council the applicant shall subject to three months notice, remove the said temporary building at his own expense and without claiming compensation from the Minister of Transport and/or the Hendon Borough Council
- (3) That the proposed access shall be temporary and subject to revision as and when required by the Minister of Transport
- (4) That before the temporary means of access is constructed, formed or laid out the applicant shall submit to the Hendon Borough Council a plan showing the position, width, gradient and mode of construction of a crossing extending from the temporary means of access to the carriageway of the trunk road and he shall construct such crossing at his own expense and to the satisfaction of the Hendon Borough Council, in accordance with the plan as submitted or required by the Hendon Borough Council to be amended.

Appln. No.	Description and Situation.	Public Health Act, 1936.	Town Planning.	Restriction of Ribbon Development Act, 1935.
A.8004	Garage, 27, Offham Slope, N. 12. Owner and Applicant—R. D. Watson	Approved	-	-
A.8008	Garage, 86, Engel Park, Mill Hill. Owner and Applicant—E. O. Edkins	Approved	-	-
A.8011	Extension to warehouse, south side, Colindale Avenue, N.W. 9. Owner and Applicant—A. Garstin & Co. Ltd.	Approved	-	-
A.8020	Garage, 482, Watford Way, N.W. 7. Owner and Applicant—T. W. Jones	Approved	-	-
A.8025	Workshop, Romac Works, Edgware Road, N.W. 9. Owner and Applicant—Romac Motor Accessories Ltd.	Approved	-	-
A.7913	Garage, 29, Angus Gardens, N.W. 9. Owner and Applicant—E. H. Hatfield	Approved	-	-
A.7966	Conservatory, 29, Park Grove, Edgware. Owner and Applicant—W. D. Brown	Approved	-	-

12.—BUILDING BYE-LAWS—MINISTRY OF HEALTH AMENDMENTS:

It was reported that the Council's draft building bye-laws had been returned by the Minister of Health, amended to bring them as close as possible into conformity with the Ministry's model bye-laws. Similar action has been taken in respect of many other Local Authorities and no useful purpose would appear to be served by making further representations to the Minister.

RESOLVED TO RECOMMEND—

- (1) That the Borough Surveyor be authorised to interview the officials of the Ministry with a view to agreeing the draft of the amended bye-laws.
- (2) That upon an intimation from the Minister of Health as to the agreed form of the proposed bye-laws the Town Clerk be authorised to issue notice of intention to apply for confirmation of such bye-laws—Section 250, Local Government Act, 1933, and Section 61 (3), Public Health Act, 1936.

13.—TEMPORARY CAR SHELTER—221, HALE LANE, EDGWARE:

The Committee considered the reference from the Rating and Valuation Committee (22/3/39—3) regarding the erection of a temporary car shelter at the above premises.

RESOLVED—That the matter be referred to the Borough Surveyor to submit a report to the next meeting.

14.—PUBLIC HEALTH ACT, 1936, SECTION 53:

It was reported that the under-mentioned consents in respect of temporary buildings required cancellation by reason of the removal or replacement of the buildings:—

4074	A.4806
4786	A.4957
5026	A.5322
5095	A.5398
5739	A.5605
6945	A.5641
8161	A.5649
8846	A.5977
9945	A.6250
A. 149	A.6633
A. 496	A.6805
A.2759	A.7332
A.3103	

RESOLVED TO RECOMMEND—That such consents be cancelled accordingly.

NAMING AND NUMBERING OF STREETS.

15.—HALE FARM ESTATE, EDGWARE:

The Borough Surveyor reported on a letter from The Aldersgate Estates Ltd., suggesting the names "Alders Road" and "Alders Close" for the two closes they are constructing off Hale Lane. There would not appear to be any objection to the proposal.

RESOLVED TO RECOMMEND—That the names "Alders Road" and "Alders Close" be approved for the roads in question.

16.—DOLLIS ROAD, HENDON:

A letter was considered from the Finchley Borough Council intimating that they proposed to re-name the section of Dollis Road within the area of Finchley, as "Brook Road," but before arriving at a final decision in the matter they invite Hendon to submit their views, if any, on the proposal.

A letter was also considered from Mr. A. Voysey stating that he had informed the remaining residents of the road of the Council's decision to invite suggestions for an entirely new name for the road in question. (B. & T.P.C., 13/2/39—25).

RESOLVED TO RECOMMEND—

- (1) **That the Finchley Borough Council be informed that the Town Council have no observations to offer in regard to their proposal relating to the alteration in the name of the portion of the road within Finchley.**
- (2) **That the letter from Mr. Voysey be duly noted.**

17.—NORTH END ROAD, GOLDERS GREEN:

The Committee considered a letter from the London County Council intimating that an Order had been made under Part IV. of the London Building Act, 1930, re-naming as "North End Way" as from the 1st July, 1939, the section of North End Road within the Borough of Hampstead.

It is pointed out that in response to the service of thirty-five statutory notices of the proposal, no objections were received, and in these circumstances it is suggested that the Hendon Borough Council may like to reconsider its decision not to re-name the portion of the road within Hendon. (B. & T.P.C., 16/1/39—29).

RESOLVED TO RECOMMEND—That no variation be made in the Council's previous decision in the matter.

18.—BRAMPTON LANE, HENDON, AND HYVER HILL, MILL HILL:

The Town Clerk reported that no objections had been received in connection with the proposed naming and re-naming of the under-mentioned roads:—

Passageway off Brampton Grove	To be known in future as "Brampton Lane."
Hyver Hill Road, Mill Hill To be known in future as "Hyver Hill."

(B. & T.P.C., 13/2/39—24, and 13/3/39—19).

RESOLVED TO RECOMMEND—

- (i) **That under powers conferred by Section 18 of the Public Health Act, 1925, the Council do now by Order assign the names above indicated.**
- (ii) **That the Corporate Seal be affixed to the necessary Orders.**

19.—TITHE WALK, HENDON (NORTH SIDE) AND GREAT NORTH WAY, HENDON (PART OF):

The Borough Surveyor asked for authority to serve re-numbering notices in respect of the properties situate on the north side of Tithe Walk, Hendon, and also in respect of the properties situate in the section of Great North Way, Hendon, between West side and Chatsworth Avenue.

RESOLVED TO RECOMMEND—That authority be given to the Borough Surveyor to serve the necessary notices requiring the re-numbering of the properties situate in the portions of the roads concerned.

Report of the Rating and Valuation Committee.

2nd May, 1939.

COMMITTEE:

*Councillor H. P. Small (*Chairman*).

Aldermen:

S. H. Egan, J.P.,
(*Deputy Mayor*),

*B. Flowers.

Councillors:

*E. Arter, M.C., M.I.A.E.,
*H. Connell, J.P.,

E. J. Cox,
*A. W. Curton,

W. A. Hicks,
*C. F. Windust.

* denotes Member present.

VALUATIONS.

1.—65th PROPOSAL LIST:

Valuation Sheets Nos. 12 to 17 were submitted containing assessments included in the above List, which comprises 205 entries (Hendon 144, Edgware 61). This List was approved by the Central Middlesex Assessment Committee on the 19th ultimo and resulted in a net increase of £6,630 (Hendon £5,500, Edgware £1,130).

There were twelve objections and two de-rating claims by Ratepayers to entries in the List. The assessments proposed were confirmed in eight cases, two objections were withdrawn, one reduction made, and in the remaining case the hearing was adjourned. The Claims for de-rating were allowed in both cases.

RESOLVED—That the assessments contained in Valuation Sheets Nos. 12 to 17 be approved and signed.

2.—66th AND 66 (A) PROPOSAL LISTS:

Valuation Sheets Nos. 1 to 4 were submitted containing 34 entries in respect of further proposed assessments of Railway "Let Out" Properties, some of which are additional to, and others in substitution of, proposals contained in the 60th and 61st Proposal Lists.

RESOLVED—That the assessments contained in Valuation Sheets Nos. 1 to 4 be approved and signed.

3.—67th PROPOSAL LIST:

It was reported that this List contained 40 entries in connection with the proposed consideration and/or re-valuation of "On licensed" premises in the Borough and had been made in accordance with the suggestion of the County Valuation Committee and the instructions given by the Rating and Valuation Committee on the 21st February last.

Noted.

4.—68th PROPOSAL LIST:

Valuation Sheets Nos. 1 to 14 were submitted containing 175 entries (Hendon 133, Edgware 42). This List will be deposited with the Central Middlesex Assessment Committee on the 12th instant and subject to objections will be approved on the 19th instant.

RESOLVED—That the assessments contained in Valuation Sheets Nos. 1 to 14 be approved and signed.

5.—MIDDLESEX COUNTY COUNCIL (GENERAL POWERS) ACT, 1938:

The Committee considered, in relation to rating, certain premises registered under the above Act for the storage and sale of food, particulars of such premises being referred from the Public Health and Medical Services Committee, 6/3/39—16).

RESOLVED—That the Chief Rating and Valuation Officer be instructed to submit a report on the matter to the next meeting.

Report of the Air Raid Precautions Committee.

24th April, 1939.

COMMITTEE:

*Councillor E. Arter, M.C., M.I.A.E. (*Chairman*).

Aldermen:

*W. R. Clemens, F.C.A.,

*J. J. Copestake, J.P.

Councillors:

*F. H. Bate,
F. J. Collins,
*A. W. Curton,
*J. Griffiths,
*W. A. Hicks,

*G. H. Hignett,
*L. Hirshfield,
*A. A. Naar, M.B.E.,
C. Pinkney,
H. G. Potter, J.P., F.S.I.,
(*Mayor*),

*T. J. Scott,
W. H. N. Shakespeare,
M.C., A.F.C., J.P.,
*C. F. Windust.

* denotes Member present.

1.—MULTI-PURPOSE BUILDINGS:

The Town Clerk reported that he had received an intimation from the County A.R.P. Officer that consent to the construction of the three multi-purpose buildings could be assumed and that the Council could now proceed with the necessary steps for erection.

The Borough Surveyor reported that he proposed to proceed first with the multi-purpose building to serve the South (No.III.) Division and that plans and estimates would be prepared and the advertisement inviting tenders issued at the earliest possible date.

RESOLVED TO RECOMMEND—That the Borough Surveyor be instructed to prepare plans and estimates and advertise for tenders for the erection of the three multi-purpose buildings forthwith.

Gndendum

Having considered the matter in its financial bearing, the Finance & General Purposes Committee Recommend—That the following be added:—

“That application be made to the Minister of Health for sanction to the borrowing for the maximum period available of the sum of £29,000 made up as follows:—

	£
Buildings—£9270 x 3	27810
Quantity Surveyor's Fees	556
Clerk of Works	350
Plans, loan charges etc.	284
Total	£29,000”

2.—OFFICE EQUIPMENT:

The Town Clerk reported that he ordered certain office equipment, i.e., desks, chairs and typewriters, for the Air Raid Precautions section of his Department, and the Committee have duly **noted and approved** such action.

3.—TRENCHES:

It was reported that the Home Office (A.R.P. Department) had signified their approval to the completion of the trenches constructed in the Borough during the Crisis, and that an expenditure not exceeding £7,741 15s. 0d. will be recognised for grant. **Noted.**

The Borough Engineer reported that work in connection with the lining of the trenches was well in hand and that satisfactory deliveries of the steel sections are being obtained from one firm only.

With regard to the alternative type of steel lining which had been ordered from Messrs. Guest, Keen, Baldwins Iron & Steel Company, he had received an intimation that this firm did not anticipate being in a position to make deliveries before the week ending the 13th May. **Noted.**

4.—PROVISION OF FURTHER TRENCHES:

The Borough Engineer reported that in accordance with the Council's instructions, plans and estimates for the construction of further trenches to provide accommodation up to 10 per cent. of the population of the Borough had been duly forwarded to the Middlesex County Council for transmission to the Home Office, but up to the present the decision of the Home Office thereon had not been received. **Noted.**

5.—AIR RAID WARDENS—ENROLMENT AND TRAINING:

The Town Clerk reported the position regarding the enrolment and training of Air Raid Wardens as follows:—

Total establishment, including reserves	2400
Trained	930
In training and completing such training this week	457
Training commencing this week	250
Enrolled, but no training commenced	35
Allocated to courses but instruction not completed and further training necessary	128
										1800
										600

Noted.

6.—CO-OPTION ON AIR RAID PRECAUTIONS COMMITTEE:

The Council on the 17th April (A.R.P.C., 27/3/39 and 12/4/39—2) decided as to the various A.R.P. services to be permitted to appoint representatives to attend Meetings of the Air Raid Precautions Committee in an advisory capacity. The Town Clerk has now asked the Committee for directions as to the procedure to be adopted in obtaining such representation.

RESOLVED—

- (a) **That with regard to the representation of the Air Raid Wardens' Organisation, the three Divisional Wardens be asked to submit a nomination for consideration by the Committee.**
- (b) **That Mr. C. E. J. West (Liaison Officer of the St. John Ambulance Brigade) be asked to nominate a representative of the St. John Ambulance Brigade (Men and Women).**
- (c) **That Mrs. J. F. Harvey (Divisional Secretary of the British Red Cross Society) be asked to nominate a representative.**
- (d) **That the Chief Officer of the Fire Brigade be asked to nominate a representative of the Auxiliary Fire Service.**
- (e) **That the Borough Engineer be asked to obtain a nomination for a representative of the Decontamination Service and also a nomination for a representative of the Rescue and Demolition Service.**

AMBULANCE SERVICE.**7.—TRAINING OF AMBULANCE DRIVERS:**

The Borough Engineer reported that the organisation for the training of drivers in the ambulance service had been practically completed and that the first instructional class was being held at the Hendon Way Depot this evening. **Noted.**

8.—PURCHASE OF VEHICLES:

The Borough Engineer reported that as a matter of urgency and with the approval of the Chairman of the Committee, he had provisionally agreed to purchase three second-hand one-ton covered van-type vehicles which are in serviceable condition at the price of £15 each for the purpose of training ambulance drivers. He also reported that it was possible that three other vehicles of a similar type may be available in the near future and asked for authority to purchase these additional vehicles.

RESOLVED TO RECOMMEND—That the purchase of the three vehicles referred to above at a cost of £15 each be approved and that the Borough Engineer be authorised to purchase three similar type vehicles when available and that the approval of the County Council be obtained.

[Having considered the matter in its financial bearing, the Finance and General Purposes Committee concur in the proposal.]

9.—STRETCHER FITMENTS:

On the report of the Borough Engineer regarding the training of volunteers in the ambulance section, the Committee

RESOLVED TO RECOMMEND—That the Borough Engineer be authorised to obtain three tubular stretcher carrying racks having a carrying capacity of four stretchers at a total cost of £5 10s. 0d. and that the Middlesex County Council be notified of the action taken.

10.—SANDBAGS—STORAGE ACCOMMODATION:

The Borough Engineer reported on his negotiations with the London Passenger Transport Board regarding the use of the space under the Company's Railway arch south of Montrose Avenue, for the purpose of the storage of sandbags. (A.R.P.C., 19/4/39—14 (ii)).

The Board are prepared to allow the Council to use the arch for the purpose indicated on the basis of a quarterly tenancy at a rent of £30 per annum exclusive of rates and taxes, subject to the two ends of the arch being enclosed with fire-resisting material. This arch would provide accommodation for 250,000 sandbags, and the Borough Engineer recommended that both ends of the arch should be enclosed with 9 in. brick work, one wall being provided with suitable double doors.

The Borough Engineer also reported that closely adjacent to the arch is an old concrete platform 50 feet in length and 17 feet 6 inches in width which is in very good condition and that in view of the difficulty being experienced in obtaining adequate and proper accommodation for the storage of sandbags he recommended that this concrete platform should form the floor and foundations of a building to be erected in 9 in. brick work and finished off with a flat reinforced concrete roof. This building would provide accommodation for approximately 350,000 sandbags, and together with the Railway arch would provide central sandbag storage for no less than 600,000 bags.

The Borough Engineer estimates the cost of enclosing the Railway arch and the erection of the building on the concrete platform at approximately £200.

RESOLVED TO RECOMMEND—That, subject to the approval of the Middlesex County Council, the proposals of the Borough Engineer be approved and adopted.

[Having considered the matter in its financial bearing, the Finance and General Purposes Committee concur in the proposal.]

11.—MEDICAL SERVICES ORGANISATION:

On the report of the Medical Officer of Health, the Committee

RESOLVED TO RECOMMEND—That the Medical Officer of Health be authorised to purchase equipment for the training of the Medical Services personnel at a total cost of approximately £48.

[Having considered the matter in its financial bearing, the Finance and General Purposes Committee concur in the proposal.]

STAFF.

12.—TEMPORARY TYPIST:

The Town Clerk reported that with the approval of the Chairman of the Committee and of the County Council he had engaged a further typist on a temporary basis at a salary within the scale approved by the Middlesex County Council. **Noted.**

13.—SPECIAL CASES:

The Committee have received and duly **noted** reports from the Town Clerk, Borough Surveyor, and Medical Officer of Health in relation to certain officers of their respective Departments engaged on Air Raid Precautions duties.

14.—REPORT OF BOROUGH TREASURER:

The Committee have considered a report submitted by the Borough Treasurer giving details of the Staff engaged on Air Raid Precautions work, and

RESOLVED TO RECOMMEND—

- (a) **That Mr. A. K. Garris (Engineering Assistant), Mr. R. C. Golding (Architectural Assistant), and Miss Voss (Typist) of the Borough Engineer's Department be seconded for Air Raid Precautions duties and that application be made to the Middlesex County Council for approval to the salaries of these officers being charged to Air Raid Precautions Account;**
- (b) **That a further report be submitted by the Borough Treasurer on Air Raid Precautions staffing arrangements at the end of June.**

[Having considered the matter in its financial bearing, the Finance and General Purposes Committee concur in the proposal.]

15.—EVACUATION OF SCHOOL CHILDREN:

The Town Clerk reported that with the authority of His Worship the Mayor he was transmitting a further representation to the Home Office with a view to Hendon being scheduled as an evacuation area. **Noted.**

16.—APPOINTMENT OF CHIEF AIR RAID WARDEN:

The Council on the 24th April referred back for further consideration the Committee's recommendation regarding the appointment of a Chief Air Raid Warden. (A.R.P.C., 19/4/39—9).

The Committee have given further consideration to the question and have also received a letter on the subject from Mr. C. N. Gardner, Acting Sector Warden in Division II. (Central), H. 76.

After further consideration of the question, the Committee

RESOLVED TO RECOMMEND—

- (a) That no Member of the Council be appointed to act as Chief Air Raid Warden.
- (b) That the Air Raid Precautions Officer be asked to carry out the duties of Chief Warden in addition to A.R.P. Officer for a period of three months, the position to be reviewed at the expiration of this period.

17.—MEETINGS OF COMMITTEE:

RESOLVED—That, excepting in the case of matters of emergency arising, the next meeting of the Committee be held on Tuesday the 16th May.

Report of the Finance and General Purposes Committee.

1st May, 1939.

COMMITTEE:

*Alderman W. R. Clemens, F.C.A. (*Chairman*).

Aldermen:

J. J. Copestake, J.P.,

S. H. Egan, J.P.

*B. Flowers.

(Deputy Mayor),

Councillors:

*E. Arter, M.C., M.I.A.E.,

*L. Hirshfield,

*C. R. Richardson,

*F. J. Collins,

*P. Lightfoot,

*T. J. Scott,

A. W. Curton,

*A. A. Naar, M.B.E.,

W. H. N. Shakespeare,

*F. W. Gilpin,

*C. Pinkney,

M.C., A.F.C., J.P.

*C. H. Hignett,

*H. G. Potter, J.P., F.S.I.

*H. P. Small.

(Mayor),

* denotes Member present.

1.—CASH STATEMENT:

The Financial and Statistical Appendix has been examined by Councillor F. J. Collins, who reported as follows:—

STATEMENT OF RECEIPTS, PAYMENTS AND BALANCES:

1st April, 1938, to 31st March, 1939.

	£	s.	d.
Commencing Balance	119686	16	10
Less 1937/38 Cheques since issued	1913	1	9
	117773	15	1
	£	s.	d.
Receipts (Appendix, page 1):—			
Previously Reported	1996139	11	11
Now Reported	350397	10	1
	2346537	2	0
	2464310	17	1
Payments (Appendix, page 2):—			
Previously Reported	1910370	4	7
Now Reported	439383	19	3
	2349754	3	10
Less Cheques Cancelled and Not Issued	1819	10	11
	2347934	12	11
Balance at 31st March, 1939 (Appendix, page 3)	£116376	4	2

2.—RATE COLLECTION ACCOUNT (Appendix, page 4):

Rate Collection 1st April, 1938, to 31st March, 1939.

	Arrears of Rates and Costs.		Current Rate.		Total.	
	£	s. d.	£	s. d.	£	s. d.
Now reported	163	12 2	13764	9 2	13928	1 4
Previously reported	9084	16 5	959192	9 5	968277	5 10
	£9248	8 7	£972956	18 7	£982205	7 2

3.—STATEMENT OF EXPENDITURE AND INCOME ON RATE FUND ACCOUNTS
(Appendix, pages 5/6):

The Borough Treasurer submitted a Statement of Expenditure and Income for the period from 1st April, 1938, to 31st March, 1939.

4.—ACCOUNTS EXAMINED AND APPROVED FOR PAYMENT (Appendix, page 7):

List of Accounts Submitted to Rota.

REPORTED: That pursuant to the Finance and General Purposes Committee Instruction No. 2 and Resolutions of the Council, the following accounts as listed in the Expenditure Journal had been examined and approved; that in view of the urgency of such accounts the necessary Pay Orders had been prepared and signed as authority to the Borough Treasurer to draw cheques, and that copies of such Pay Orders had been forwarded to the Corporation's Bankers with instructions to honour only such cheques as appeared in such Pay Orders:—

List No.	Date Examined.	Examined by.	General A/c.		Loans Pool.	
			£	s. d.	£	s. d.
—	Previously Reported (Per Minutes, page 547)	—	164047	2 1	130204	16 6
249—254	27th March, 1939	Councillor F. J. Collins	20514	15 1	—	—
255	27th March, 1939	Councillor F. J. Collins	73794	6 8	—	—
258	27th March, 1939	Councillor F. J. Collins	3989	9 4	—	—
256—257	27th March, 1939	Councillor F. J. Collins	—	—	21833	9 7
259	27th March, 1939	The Mayor (Councillor H. G. Potter)	25000	0 0	—	—
	Per Bank Account (Appendix, page 3)	—	£439383	19 3	—	—
260	4th April, 1939	The Mayor (Councillor H. G. Potter)	3520	3 3	—	—
1	4th April, 1939	The Mayor (Councillor H. G. Potter)	6602	6 6	—	—
261—266	13th April, 1939	The Mayor (Councillor H. G. Potter)	3248	10 1	—	—
2—4	17th April, 1939	Councillor G. R. Richardson	23812	18 8	—	—
267—269	24th April, 1939	Alderman J. J. Copestake	2845	13 6	—	—
5—6	24th April, 1939	Alderman J. J. Copestake	25342	15 2	—	—
7	24th April, 1939	Alderman J. J. Copestake	549	2 1	—	—
8	24th April, 1939	Alderman J. J. Copestake	—	—	31	14 5
9	1st May, 1939	Councillor F. J. Collins	3850	3 0	—	—
270—274	1st May, 1939	Councillor F. J. Collins	4648	9 1	—	—
			£74420	1 4	£31	14 5

Noted.

5.—STATISTICAL RETURNS:

Statistical returns, details of which appear in the appendix to this Report, were submitted and noted.

6.—REQUISITION:

A requisition for general stationery amounting to £291 9s. 3d. was submitted and approved.

STAFF.

7.—ABSENCE OF STAFF:

It was reported that since the last meeting 20 members of the staff had been absent owing to illness. **Noted.**

8.—INCREMENTS:

The Committee have considered the recommendations of the Chief Officers in cases due for scale increments for the period to the 1st June next, together with information as to service, grade, present salary and the amount of increment due according to scale.

RESOLVED TO RECOMMEND—That scale increments be awarded in all cases recommended by the Chief Officers and enumerated in the Borough Treasurer's report.

9.—TOWN CLERK'S DEPARTMENT:

It was reported that Mr. R. C. Maidlow would attain the age of 18 years on the 3rd June next, and a recommendation was submitted for his promotion to the permanent staff.

RESOLVED TO RECOMMEND—That Mr. R. C. Maidlow be appointed to the permanent staff as from the 3rd June next, in Grade E.

10.—PUBLIC HEALTH DEPARTMENT:

The Chairman of the Public Health Committee reported that Miss D. Watkins, a Shorthand Typist in the Public Health Department, had tendered her resignation to take effect on the 31st May, 1939, and recommended that Miss V. Bisset, who is at present employed as a temporary Shorthand Typist under the Council's Air Raid Precautions Scheme in the Department, be appointed to fill the vacancy as from the 1st June, 1939. Miss Bisset has passed the medical examination.

RESOLVED TO RECOMMEND—That Miss V. Bisset be appointed as from 1st June next, as Shorthand Typist in the Public Health Department at salary according to scale in the Typists Grade, and that authority be given for the engagement of a temporary Shorthand Typist at a remuneration of £2 10s. 0d. per week.

11.—NATIONAL SERVICE:

The Committee have received a report summarising the number of employees who have obligations in respect of National Service which shows Regular Forces Reserves 31, Territorial Force 13 and Voluntary Services 32 (F. & G.P.C., 20/2/39—12). In connection with National Service generally Circular 1808 has been received from the Minister of Health which intimates that legislation is being prepared, for introduction in the event of an emergency, which would provide that a local authority may grant leave of absence during the emergency to an employee to enable him to serve in H.M. Forces or in civil defence, and may make up the difference between his new pay and the remuneration which he would have received if he had remained in the actual service of the local authority. The position of the employee as regards superannuation would be safeguarded and the emergency service would be reckonable for superannuation purposes. Provision on similar lines would be made for an employee of a local authority who remains with the authority but serves in the emergency on civil defence.

Another question relates to the position of employees on their return to civil duty; it has been suggested that local authorities should give such assurance as they can that the employees would be reinstated in their original employment. Whilst it is appreciated that the question of continued employment after return from service is a matter for the local authority concerned, the Minister wishes it to be understood that they might properly keep open the places of their employees who, with their permission, undertake full time National Service.

The Committee propose to give further consideration to the whole question of the staff in relation to National Service at their next meeting.

SUPERANNUATION.

12.—CONTRIBUTORY EMPLOYEES:

In order to comply with the Local Government Superannuation (Administration) Regulations, 1938, it is now necessary to take into consideration:—

- (a) Whether those persons who have entered the service of the Council since the 5th December, 1938, are, or are not, contributory employees within the meaning of the 1937 Act.
- (b) Whether there has been any change in the circumstances of the employment of other employees of the Council which is material for the purposes of the 1937 Act.

In pursuance of the Regulations the Borough Treasurer reported upon those persons who had entered the service since the 5th December and submitted schedules as to:—

- (i) those entitled to become contributory employees, and
- (ii) cases in which there have been changes in the circumstances of employment.

RESOLVED TO RECOMMEND—

- (i) **That the schedules be approved and signed by the Chairman.**
- (ii) **That the Borough Treasurer be authorised to issue the necessary notifications in accordance with Article 5 of the Regulations, 1938.**

13.—ACTUARIAL VALUATION:

The Borough Treasurer reported that the actuarial valuation of the Superannuation Fund under the Act of 1937 will be due as at the 31st March, 1940, and asked for authority to make arrangements in the matter.

RESOLVED TO RECOMMEND—**That authority be given for the necessary arrangements to be made with Messrs. R. Watson & Sons of Empire House, St. Martins le Grand, for the valuation of the fund and for consequential matters in connection therewith.**

14.—ISOLATION HOSPITAL—STAFF:

For the purposes of the Local Government Superannuation Act, 1937, the following appointments to the Hospital Staff are placed on record:—

Temporary Staff.—

Anderson, Miss M. L.	Staff Nurse as from	5. 4.39.
Baggott, Miss E. M.	Staff Nurse as from	14. 3.39.
Bowen, Miss M.	Probationer as from	3. 3.39.
Evans, Miss P. M.	Probationer as from	23. 3.39.
Fawcett, Miss R. E.	Probationer as from	21. 2.39.
Sida, Miss J. M.	Probationer as from	9.12.38.

15.—REFUND OF CONTRIBUTIONS:

It was reported that repayment of superannuation contributions amounting to £3 11s. 2d. was due in respect of the resignation of Miss L. Clayton, Staff Nurse at the Isolation Hospital.

RESOLVED TO RECOMMEND—That authority be given for payment of the amount stated.

16.—GOVERNMENT GRANTS:

In the calculation of Government Grants contributions by a Local Authority to a Superannuation Fund have always been excluded and this practice appeared to be reasonable having regard to the fact that superannuation of Local Government employees was not compulsory.

Since the 1st April, 1939, however, superannuation of Local Government employees has been compulsory (although not pursuant to the same Act of Parliament in every case) and it was anticipated that any contributions made by a Local Authority after that date would rank as grant earning expenditure. This would not, however, appear to be the case, and the Borough Treasurer asked for authority to take up the general question with the Ministry of Health.

RESOLVED TO RECOMMEND—That the Borough Treasurer be authorised to act on the lines indicated.

17.—INVESTMENTS:

A matter in connection with the investment of assets of the Superannuation Fund has been referred to the Chairman and the Borough Treasurer.

RESOLVED TO RECOMMEND—That power to act be given in the matter.

18.—HENDON URBAN DISTRICT COUNCIL ACT, 1929—SECTION 44:

The Borough Treasurer reported with regard to correspondence with Mr. G. S. M. Mair regarding his claim for compensation under the above Act in respect of the loss of his offices as Clerk to the Edgware Parish Council and to the Edgware and Little Stanmore Joint Lighting and Fire Committee, on the transfer of the Parish of Edgware to Hendon.

RESOLVED TO RECOMMEND—That Mr. G. S. M. Mair be informed that the Council are prepared to assess his claim at a total commuted value of £77 18s. 5d.

PRIVATE STREET IMPROVEMENTS.

19.—AGREEMENTS:

It was reported that 14 agreements to pay private improvement expenses by instalments had been completed since the last meeting.

20.—APPORTIONMENTS:

The Borough Surveyor submitted the following apportionments of expenses of private street works under Section 150 of the Public Health Act, 1875:—

Name of Road.	Total Amount of Apportionment.		Rate per Foot of Frontage.		Width of Road. Feet.
	£	s. d.	s.	d.	
St. Albans Lane, Golders Green	535	18 7	9	7.322	16 and 10
Rectory Lane, Edgware	1282	9 8	14	11.142	21

Noted.

The Borough Treasurer also submitted the following statement with regard to the completion of the above works:—

Contract.	Original estimated cost.	Amount of Tender.	Actual Cost.
	£	£	£
St. Albans Lane	774	580	536
Rectory Lane	1627	1444	1282
	<u>£2401</u>	<u>£2024</u>	<u>£1818</u>

21.—PRIVATE WORKS:

The Borough Surveyor submitted the following statement as to agreements for the execution of private works:—

	Date of Agreement.	Amount of Deposit.
	1939.	£
C. E. Matthews—Connections, Hanks Lane	18th March	35
E. & J. Cotton, Ltd.—Connections, etc., Woodfield Avenue	17th March	100
Lightban (Construction), Ltd.—Crossing, Broadfields Avenue, Edgware	21st March	15
Cropley Bros., Ltd. — Connections, West Heath Road	24th March	28
Cramb Bros.—Crossing, Holders Hill Road	1st April	26
Grand Union Canal Co.—Crossing, Edgware Road	5th April	25
Perrys (Ealing), Ltd.—Crossings, The Burroughs	14th April	95
Albert Monk—Connections, Colindale Avenue	12th April	30
F. L. Manning—Crossing, etc., Hendon Wood Lane	6th April	16
Miss R. Ford—Connections, Page Street	12th April	40
R. Schooley & Son — Connections, Brampton Grove	14th April	40
Pitchers, Ltd.—Connections, Mowbray Road	20th April	30
T. W. Heath, Ltd. — Connections, Rushgrove Avenue	21st April	20
Berney & Marks—Connections, Church Road and Parson Street.....	24th April	80

Noted.

22.—LOANS—REPAYMENTS:

The Borough Treasurer reported that Loan No. 265 (F.E.R.) for £500 at 3½ per cent. falls due for repayment on the 27th May, and that Loan No. 403 (H.M.P.S.) £300 at 3½ per cent. was repaid to the extent of £100 on the 24th April last. **Noted.**

INSURANCES.

23.—INSURANCE FUND:

RESOLVED TO RECOMMEND—That the following Insurance be carried by the Council's Fund:—

Description.	Value for insurance. £	To be insured with Co. £	To be carried by Fund. £	Commenc- ing Date.	Annual Premium. £ s. d.
Colindale School Extensions:—					
Buildings, etc.	6310	3160	3150	12/4/39	1 16 9

24.—THIRD PARTY, ETC., INSURANCE CLAIMS:

The following statement was submitted and noted:—

Third Party, Driving, etc., Accidents:—

No. of cases in hands of Insurance Companies brought forward	16
No. of new cases	18
	34
No. of cases settled or otherwise disposed of	19
	15
Still Outstanding	15
Claims paid by Insurance Companies	£143 5 3

Workmen's Compensation Cases:—

No. of cases on books, 20/3/39	5
No. of new cases	6
	11
No. of cases taken out of compensation or otherwise disposed of	8
	3
No. of cases now under compensation or pending	3

25.—RENEWALS:

The Borough Treasurer reported with regard to proposals for the renewal of certain fire insurance policies with the Municipal Mutual Insurance Limited for a period of 5 years, in consideration of which special discounts will be allowed from renewal premiums.

RESOLVED TO RECOMMEND—That authority be given for the renewal of such policies on the understanding that such action will not prevent reductions being made in the sums insured for the benefit of the Corporation's Insurance Fund, and that the Corporate Seal be affixed to any necessary documents.

26.—AUDITOR'S REPORT:

The following report was submitted:—

28th March, 1939.

The Mayor, Aldermen and Councillors
of the Borough of Hendon.

Gentlemen,

I have to report that the audit of your accounts for the year ended 31st March, 1938, was concluded on the 24th instant.

Payment of Wages:

A case occurred during the year in which a workman was impersonated by someone who drew his wages. The certificate of identity was signed by a Superintendent to whom the man was not known. The men either should have metal identity discs issued to them to be surrendered in exchange for their pay packets or they should be identified by a foreman to whom they are known.

Wages Pay Books are prepared for the two principal Pay Districts but embrace only about two-thirds of the employees. The evidence as to payment to the remainder is obtained on the men's individual Wages Sheets. To facilitate payment control and subsequent audit scrutiny I would suggest that all wages be entered in Wages Pay Books, there being a separate book for each Pay Clerk with a separate section for each of his pay rounds and that evidence as to payment be obtained therein.

Capital Expenditure in Excess of Borrowing Powers:

£878 14s. 1d. has been expended in the work of laying-out Copthall Playing Fields, the further execution of which has been deferred for two years. In the absence of borrowing powers this amount should be charged to revenue.

Cash Collections at the Town Hall:

Collections are banked twice a day. A deposit is made in the afternoon on account of each day's collection, the remainder of which is banked the next morning. The desirability of a night-safe in the Town Hall was pointed out to your Treasurer. In addition to affording security for the money overnight, this would ensure that the balance of each day's takings not banked in the afternoon is kept intact from the next morning's money.

I am, Gentlemen,

Your obedient Servant,

(Signed) O. E. BRIGDEN,

District Auditor.

The Committee have duly noted the above report, and in order to give effect to the points raised therein now

RECOMMEND—

- (1) **Payment of Wages:—That the Borough Treasurer be authorised to make any necessary alterations in the method of paying wages in consultation with the Borough Engineer and Surveyor, and to obtain such equipment as may be required;**
- (2) **Capital Expenditure:—That the expenditure of £878 14s. 1d. on the lay-out of Copthall Open Space be charged to General Rate Account;**
- (3) **Cash Collections:—That authority be given for an additional safe with two independent locks and for the fitting of automatic alarms to the doors of two strong rooms in the Borough Treasurer's Department.**

The Committee have also given preliminary consideration to the desirability of a night patrol, and have requested the Town Clerk to submit a report thereon, in consultation with the Borough Engineer and Surveyor.

27.—HENDON GROVE—FENCING:

The Committee have received a further representation from Sister Albertina regarding a deputation being received with reference to the fencing between Hendon Grove and the Convent property. (F. & G.P.C., 20/2/39—29).

RESOLVED TO RECOMMEND—That a deputation be received at the next meeting of the Committee.

28.—CLITTERHOUSE PLAYING FIELDS:

The Borough Surveyor submitted a letter from the Minister of Transport stating that he wished to acquire certain plots of land and to obtain an easement over other plots in connection with the construction of a subway at Hendon Way, near Wessex Gardens. The plots concerned are owned by the Corporation and form the entrance to the Clitterhouse Playing Fields.

The Minister suggests that the question of compensation should be referred to the Valuation Department of the Inland Revenue.

RESOLVED TO RECOMMEND—That, subject to the consent of the Minister of Health, the sale of the plots of land be approved and the required easements granted, at a figure to be agreed by the District Valuer, subject to the maintenance of a proper access to the Park which can be closed even when the subway is open.

29.—BARNET LANE:

The Borough Surveyor reported on a further offer from Mr. J. F. Matheson in connection with the strip of land belonging to the Corporation fronting the Barnet—Elstree Road. (F. & G.P.C., 20/3/39—31).

RESOLVED TO RECOMMEND—That no further action be taken in the matter.

30.—DOLE STREET SCHOOL SITE:

It was reported that in the opinion of the District Valuer, the present value of the land, 5.44 acres, appropriated under an Instrument of the Minister of Health, dated the 13th November, 1938, from Housing to Education, amounted to £5,000.

RESOLVED TO RECOMMEND—That the valuation be accepted and the Borough Treasurer authorised to make the necessary adjustments to the Accounts.

31.—“RAVENSFIELD”:

The Town Clerk reported that in connection with the proposed allocation of half of the property known as “Ravensfield” for the purposes of Air Raid Precautions Offices it has been found more suitable for this accommodation to be provided at Derby House, leaving the whole of “Ravensfield” for the purposes of Food Control, if and when the necessity arises.

His Worship the Mayor and the Borough Treasurer had been consulted in the matter, and in order to give effect to the proposal it would be necessary for the British Red Cross Society to vacate “Ravensfield” and to be offered accommodation at Burroughs House.

Position

RESOLVED—That the proposals be approved and authority given for any necessary action in the matter.

32.—MUNICIPAL HOLIDAY CAMPS:

In January last, the Council received an invitation from the London and Middlesex National Fitness Committee to appoint a representative to attend a Conference of Local Authorities in connection with the establishment of Holiday Camps. Alderman J. J. Copestake was appointed, but unfortunately he was unable to attend.

At the Conference held on the 25th January, a Committee was appointed to investigate and report on machinery suitable to ensure collaboration between Local Authorities who contemplate establishing Holiday Camps, and the Committee have recommended the establishment of a permanent body of delegates from Local Authorities in London and Middlesex to take further action in the matter.

The Council are invited to appoint a representative to the standing Conference, and the Committee

RECOMMEND—That Councillor T. J. Scott be appointed as the Council's representative.

33.—DEFENCE REGULATIONS:

The Committee have considered a communication, M.D.W.B. 15/1, dated 14/4/39, with regard to, in certain circumstances, a proposed Order under the Defence Regulations and gave instructions thereon as appearing in MS. in the Committee's Minute Book.

34.—COUNTY AND LOCAL EXPENDITURE:

The Committee have received and duly **noted** the following resolutions:—

Mill Hill Ratepayers' and Residents' Association:—

"That this Meeting of Mill Hill Ratepayers' and Residents' Association re-affirms its support to the protests being made daily to M.P.'s, Bankers, the Press, etc., against the heavy increase in local taxation.

It considers that especially in view of the Government's demands due to rearmament, local expenditure must be reduced and therefore urges the Middlesex County Council and Hendon Borough Council, each to appoint a special committee whose duty it shall be to find ways and means of curtailing expenses."

Council of the Borough of Finchley:—

"That this Council immediately takes steps to obtain the collaboration of other Local Government Bodies in the County with a view to a joint representation being made to the Middlesex County Council pressing for a complete overhaul of County finance, with the object of achieving a considerable reduction in immediate and future expenditure."

35.—HENDON PEACE COUNCIL:

The following resolutions of the above Council were submitted and **noted**:—

"This meeting of the Executive Committee of the Hendon Peace Council expresses its horror at the forcible annexation of Czecho-Slovakia and urges His Majesty's Government to make any repetition of such action impossible by forming a united Peace alliance with France, U.S.S.R., U.S.A. and by adopting a policy of Collective Security under the League of Nations."

"This meeting of the Executive Committee of the Hendon Peace Council urges that as a result of recent events in Czecho-Slovakia and Spain, victims of political, racial and religious persecution be given shelter in this country and that a Government department be appointed to deal with the settlement of such refugees and also follow the example of the U.S.A. by imposing economic restrictions on aggressor countries."

36.—STANDING ORDERS:

The Committee have considered the reference from the Council of the 27th March, and after making amendments to Standing Order No. 9 to provide that the Mayor shall be one of the 18 Members of the Council appointed to the Education Committee, have decided to

RECOMMEND—That the Standing Orders set out in Appendix I. to this report be made in accordance with the provisions of Part V. of the Third Schedule to the Local Government Act, 1933, and that the Corporate Seal of the Council be affixed thereto.

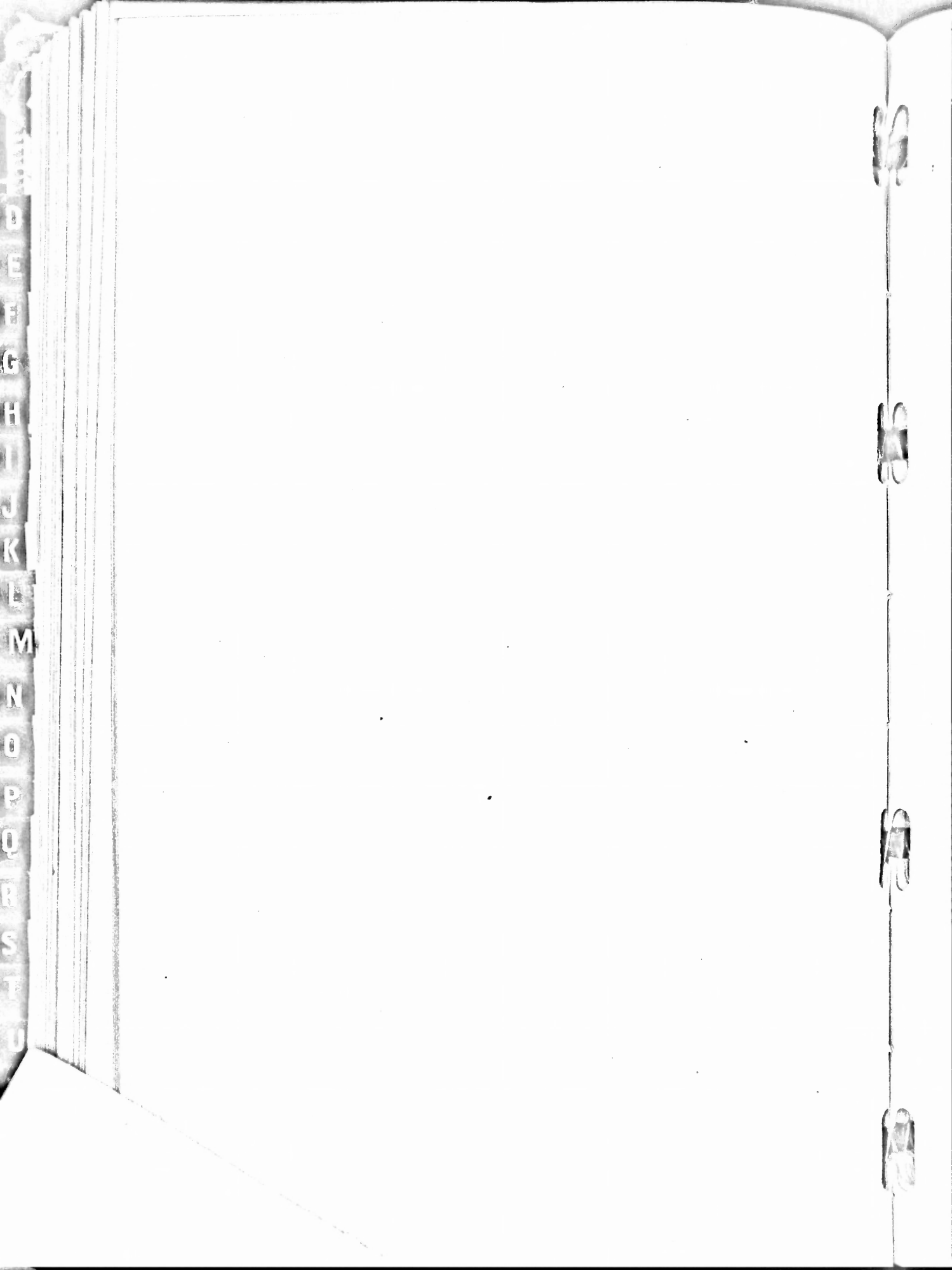

A
B
C
D
E
F
G
H
I
J
K
L
M
N
O
P
Q
R
S
T
U

Small metal fasteners or clips along the right edge of the page.

APPENDIX I.

Borough of Mendon

MEETINGS AND PROCEEDINGS OF THE COUNCIL
and
COMMITTEES

Statutory Provisions

STANDING ORDERS
AND
Instructions to Committees

LEONARD WORDEN,
Town Clerk.

X
Y
D
E
F
G
H
I
J
K
L
M
N
O
P
Q
R
S
T
U
V
W



Statutory Provisions.

Local Government Act, 1933.

(Commencement—1st June, 1934.)

MEETINGS AND PROCEEDINGS OF LOCAL AUTHORITIES.

Section 75.—The provisions of Parts I. to V. of the Third Schedule to this Act shall have effect as respects the meetings and proceedings of local authorities and of committees thereof.

✦ ✦ ✦

Third Schedule.

Part II.

BOROUGH COUNCILS.

1.—Days and Hours of Meetings.

(1) The council of a borough shall in every year hold an annual meeting and at least three other meetings, which shall be as near as may be at regular intervals, for the transaction of general business.

(2) The annual meeting shall be held at twelve noon, or at such other hour as the council may from time to time determine, on each ninth day of November, and the other meetings shall be held at such hour on such other days before the first day of November next following as the council at the annual meeting decide, or by standing order determine.

2.—Convening Meetings.

(1) The mayor may call a meeting of the council at any time.

(2) If the mayor refuses to call a meeting after a requisition for that purpose, signed by five members, or by one-fourth of the whole number of members, of the council, whichever is the less, has been presented to him, or if, without so refusing, the mayor does not call a meeting within seven days after such requisition has been presented to him, any five members, or one-fourth of the whole number of members, of the council, whichever is the less, on that refusal or on the expiration of seven days, as the case may be, may forthwith call a meeting of the council.

(3) Three clear days at least before a meeting of the council of a borough:—

- (a) notice of the time and place of the intended meeting shall be published at the town hall, and where the meeting is called by members of the council the notice shall be signed by those members and shall specify the business proposed to be transacted thereat; and
- (b) a summons to attend the meeting specifying the business proposed to be transacted thereat, and signed by the town clerk, shall be left at or sent by post to the usual place of residence of every member of the council:

Provided that want of service of the summons on any member of the council shall not affect the validity of a meeting.

(4) Except in the case of business required by this Act to be transacted at the annual meeting of the council, no business shall be transacted at a meeting of the council other than that specified in the summons relating thereto.

3.—*Chairman of Meeting.*

(1) At a meeting of the council of a borough the mayor, if present, shall preside.

(2) If the mayor is absent from a meeting of the council, the deputy mayor, if chosen for that purpose by the members of the council then present, shall preside.

(3) If both the mayor and the deputy mayor are absent from a meeting of the council, or the deputy mayor being present is not chosen, such alderman, or in the absence of all the aldermen, such councillor, as the members of the council present shall choose, shall preside.

4.—*Quorum.*

Subject to the provisions of Part V. of this Schedule, no business shall be transacted at a meeting of the council of a borough, unless at least one-third of the whole number of members of the council are present thereat.

Part V.

PROVISIONS RELATING TO LOCAL AUTHORITIES GENERALLY.

1.—*Decisions on Questions.*

(1) Subject to the provisions of any enactment (including any enactment in this Act) all acts of a local authority and all questions coming or arising before a local authority shall be done and decided by a majority of the members of the local authority present and voting thereon at a meeting of the local authority.

(2) In the case of an equality of votes the person presiding at the meeting shall have a second or a casting vote.

2.—*Names of Members Present to be Recorded.*

The names of the members present at a meeting of a local authority shall be recorded.

3.—*Minutes.*

(1) Minutes of the proceedings of a meeting of a local authority, or of a committee thereof, shall be drawn up and entered in a book kept for that purpose, and shall be signed at the same or next ensuing meeting of the local authority or committee, as the case may be, by the person presiding thereat, and any minute purporting to be so signed shall be received in evidence without further proof.

(2) Until the contrary is proved, a meeting of a local authority, or of a committee thereof, in respect of the proceedings whereof a minute has been so made and signed shall be deemed to have been duly convened and held, and all members present at the meeting shall be deemed to have been duly qualified, and where the proceedings are proceedings of a committee, the committee shall be deemed to have been duly constituted and to have had power to deal with the matters referred to in the minutes.

4.—*Standing Orders.*

Subject to the provisions of this Act, a local authority may make standing orders for the regulation of their proceedings and business, and may vary or revoke any such orders.

5.—*Vacancies, etc., not to Invalidate Proceedings.*

The proceedings of a local authority, or of a committee thereof, shall not be invalidated by any vacancy among their number, or by any defect in the election or qualification of any member thereof.

6.—*Quorum in Cases of Disqualification.*

Where more than one-third of the members of a local authority become disqualified at the same time, then, until the number of members in office is increased to not less than two-thirds of the whole number of members of the local authority, the quorum of the local authority shall be determined by reference to the number of members of the local authority remaining qualified instead of by reference to the whole number of members of the local authority.

**DISABILITY OF MEMBERS OF AUTHORITIES
FOR VOTING.**

Section 76.—(1) If a member of a local authority has any pecuniary interest, direct or indirect, in any contract or proposed contract or other matter, and is present at a meeting of the local authority at which the contract or other matter is the subject of consideration, he shall at the meeting, as soon as practicable after the commencement thereof, disclose the fact, and shall not take part in the consideration or discussion of, or vote on any question with respect to, the contract or other matter:

Provided that this section shall not apply to an interest in a contract or other matter which a member may have as a ratepayer or inhabitant of the area, or as an ordinary consumer of gas, electricity or water, or to an interest in any matter relating to the terms on which the right to participate in any service, including the supply of goods, is offered to the public.

(2) For the purposes of this section a person shall (subject as hereafter in this sub-section provided) be treated as having indirectly a pecuniary interest in a contract or other matter, if—

- (a) he or any nominee of his is a member of a company or other body with which the contract is made or is proposed to be made or which has a direct pecuniary interest in the other matter under consideration; or
- (b) he is a partner, or is in the employment, of a person with whom the contract is made or is proposed to be made or who has a direct pecuniary interest in the other matter under consideration:

Provided that—

(i) this sub-section shall not apply to membership of, or employment under, any public body;

(ii) a member of a company or other body shall not, by reason only of his membership, be treated as being so interested if he has no beneficial interest in any shares or stock of that company or other body.

(3) In the case of married persons living together the interest of one spouse shall, if known to the other, be deemed for the purposes of this section to be also an interest of that other spouse.

(4) A general notice given in writing to the clerk of the authority by a member thereof to the effect that he or his spouse is a member or in the employment of a specified company or other body, or that he or his spouse is a partner or in the employment of a specified person, shall, unless and until the notice is withdrawn, be deemed

to be a sufficient disclosure of his interest in any contract, proposed contract or other matter relating to that company or other body or to that person which may be the subject of consideration after the date of the notice.

(5) The clerk of the authority shall record in a book to be kept for the purpose particulars of any disclosure made under sub-section (1) of this section, and of any notice given under sub-section (4) thereof, and the book shall be open at all reasonable hours to the inspection of any member of the local authority.

(6) If any person fails to comply with the provisions of sub-section (1) of this section, he shall for each offence be liable on summary conviction to a fine not exceeding fifty pounds, unless he proves that he did not know that a contract, proposed contract, or other matter in which he had a pecuniary interest was the subject of consideration at the meeting.

(7) A prosecution for an offence under this section shall not be instituted except by or on behalf of the Director of Public Prosecutions.

(8) The county council, as respects a member of a parish council, and the Minister, as respects a member of any other local authority, may, subject to such conditions as the county council or the Minister, as the case may be, may think fit to impose, remove any disability imposed by this section in any case in which the number of members of the local authority so disabled at any one time would be so great a proportion of the whole as to impede the transaction of business, or in any other case in which it appears to the county council or the Minister, as the case may be, that it is in the interests of the inhabitants of the area that the disability should be removed.

(9) A local authority may by standing orders provide for the exclusion of a member of the authority from a meeting of the authority whilst any contract, proposed contract or other matter in which he has such an interest as aforesaid is under consideration.

COMMITTEES.

APPOINTMENT.

Section 85.—(1) A local authority may appoint a committee for any such general or special purpose as in the opinion of the local authority would be better regulated and managed by means of a committee, and may delegate to a committee so appointed, with or without restrictions or conditions, as they think fit, any functions exercisable by the local authority either with respect to the whole or a part of the area of the local authority, except the power of levying, or issuing a precept for, a rate, or of borrowing money.

(2) The number of members of a committee appointed under this section, their term of office, and the area, if any, within which the committee is to exercise its authority, shall be fixed by the local authority.

(3) A committee appointed under this section (other than a committee for regulating and controlling the finance of the local authority or of their area) may include persons who are not members of the local authority:

Provided that at least two-thirds of the members of every committee shall be members of the local authority.

(4) Every member of a committee appointed under this section who at the time of his appointment was a member of the local authority by whom he was appointed shall, upon ceasing to be a member of the authority, also cease to be a member of the committee:

Provided that for the purposes of this section a member of a local authority shall not be deemed to have ceased by reason of retirement to be a member of the authority, if he has been re-elected a member thereof not later than the day of his retirement.

(5) Nothing in this section shall authorise the appointment of a committee for any purpose for which the local authority are authorised or required to appoint a committee by any other enactment (including any enactment in this Act) for the time being in force.

DISABILITY FOR VOTING.

Section 95.—Section seventy-six of this Act shall apply in respect of members of a committee or sub-committee of a local authority or of any joint committee appointed by agreement between local authorities, whether the committee, sub-committee or joint committee are appointed under this Part of this Act or under any other enactment, as that section applies in respect of members of local authorities, subject to the following modifications:—

- (a) as respects members of a committee or sub-committee, references to meetings of the committee or sub-committee shall be substituted for references to meetings of the local authority, and the right of persons who are members of the committee or sub-committee but not members of the local authority to inspect the book to be kept under sub-section (5) of the said section shall be limited to an inspection of the entries in the book relating to members of the committee or sub-committee; and

- (b) as respects members of any such joint committee as aforesaid, references to meetings of the joint committee shall be substituted for references to meetings of the local authority, and references to the clerk to the joint committee for references to the clerk of the authority.

STANDING ORDERS, ETC.

Section 96.—(1) A local authority appointing a committee, and local authorities who concur in appointing a joint committee, either under this Part of this Act or under any other enactment, may make, vary and revoke standing orders respecting the quorum, proceedings and place of meeting of the committee or joint committee, but subject to any such standing orders the quorum, proceedings and place of meeting shall be such as the committee or joint committee may determine.

(2) The person presiding at a meeting of a committee or joint committee appointed either under this Part of this Act or under any other enactment shall have a second or a casting vote.



STANDING ORDERS.

MEETINGS OF THE COUNCIL.

- Statutory and Ordinary Meetings.** 1.—The Annual Meeting of the Council shall be held on the 9th day of November. The remaining three Statutory Meetings and the Ordinary Meetings of the Council shall be held on such Mondays as may be determined at the Annual Meeting.
- Time of Meetings.** 2.—All meetings of the Council shall be held at 6 o'clock in the afternoon, or at such other hour as the Mayor may in special circumstances direct.
- Special Meetings.** 3.—Special Meetings of the Council may be convened and held as provided by paragraph 2, part II. of the 3rd schedule to the Local Government Act, 1933.
- Quorum.** 4.—The quorum of the Council shall be one-third of the whole number of the Council.
- Quorum at commencement.** If at the expiration of 15 minutes after the hour at which any meeting of the Council is appointed to be held, a quorum shall not be present, no meeting shall take place, but it shall be the duty of the Town Clerk to summon another meeting within seven days.
- Quorum during sitting.** If during any sitting of the Council the attention of the Mayor or Chairman be called to the fact that there is not one-third of the Members present the Town Clerk shall call over the names of such Members and if it shall appear that there be not one-third present, the Mayor or Chairman shall declare the meeting of the Council at an end, and the names of those who are present and those who are absent shall be recorded upon the minutes of the Council.
- Admission of Strangers.** 5.—Strangers shall be permitted to attend in that part of the Chamber provided for their accommodation at all meetings of the Council unless specially excluded by a vote of the Council during the whole or any portion of any meeting, subject to the following Rules and Regulations, that is to say:—
- (a) That the admission be upon the understanding that the said strangers must continue at all times seated and that no expression of opinion or noise of any kind can be allowed from them.
 - (b) That the Mayor or Chairman may at any time during the proceedings, if he thinks it necessary to secure order, direct the removal of any individual or order the portion of the Chamber provided for the accommodation of strangers to be wholly cleared.
- In Committee.** 6.—The Council may resolve itself into Committee upon a motion duly made, seconded and carried, and temporarily exclude representatives of the press from a meeting as often as may be desirable when, in the opinion of a majority of the Members present at such meeting, in view of the special nature of the business then being

dealt with or about to be dealt with, such exclusion is advisable in the public interest.

This motion may be made without notice.

7.—No proposal relating to capital works not pro-Finance. vided for in the estimates and no matter which may involve questions of principle or policy affecting the revenues or expenditure of the Council shall be considered by the Council until the Finance and General Purposes Committee shall have reported thereon.

APPOINTMENT, ETC., OF COMMITTEES.

8.—The Standing Committees of the Council shall be those which are so designated by Standing Order and they shall be appointed (as far as practicable) at the Annual Meeting of the Council. The Council may delegate to the Standing Committee such powers and duties as it deems expedient.

9.—The Standing Committees of the Council shall be the following:—

	Members of Council.	Co-opted Members.
Education	18‡	5
<i>(‡ one of whom shall be the Mayor for the time being.)</i>		
<i>Approved Scheme for the constitution of the Education Committee—see Appendix "B."</i>		
Estates, Parks and Allotments	12	4†
<i>(† for Allotments—Representatives of the Hendon Federation of Allotment Societies.)</i>		
Public Health & Medical Services	12	4*
<i>(* for Medical Services, of whom two shall be Co-opted Members of the Education Committee.)</i>		
Highways	12	—
Buildings and Town Planning	13	—
Housing	11	—
Libraries and Local Pensions	11	—
Works and Fire Brigade	12	—
Rating and Valuation	12	—
Finance and General Purposes	15	—
Air Raid Precautions	16	—

The personnel of the Finance and General Purposes Committee shall consist of:—

- 1 The Mayor.
- The Chairmen of the following Standing Committees:—
 - Education,
 - Estates, Parks and Allotments,
 - Highways,
 - Public Health and Medical Services,
 - Buildings and Town Planning,
 - Housing,
 - Libraries and Local Pensions,
 - Works and Fire Brigade,
 - Air Raid Precautions.
- 5 Other Members to be appointed at the Annual Meeting.

The personnel of the Air Raid Precautions Committee shall consist of:—

- 1 The Mayor.
- The Chairmen of the following Standing Committees:—
 - 6 { Education,
Estates, Parks and Allotments,
Highways,
Public Health and Medical Services,
Works and Fire Brigade,
Finance and General Purposes.
 - 9 One Member from each Ward.
-
- 16
-

The Mayor shall be ex-officio a member of all Committees of which he is not an appointed Member.

Ward Representation. 10.—There shall be at least one Councillor from each Ward on each of the Standing Committees, for which purpose the number of Members on the Finance and General Purposes Committee may if necessary be increased.

First Meetings and appointment of Chairmen. 11.—Each Committee shall be called together as soon as convenient after annual appointment and shall choose a Chairman.

In the absence of the Chairman, a Chairman *pro tempore* shall be appointed.

Duration of Chairmanships. 12.—No Member of the Council shall be Chairman of more than one Standing Committee nor shall he continue as Chairman of that Committee for more than two consecutive years, provided that a Member may be Chairman of the Finance and General Purposes Committee as well as of one other Committee.

Attendance of members not on Committee. 13.—Members of the Council desirous of attending any of the Committees, other than those on which they are placed, shall be entitled to do so, but such Members shall not be entitled to take part in the proceedings without the consent of the Chairman of the Meeting, nor in any case to vote.

Continuance of Standing Committees. 14.—The period of continuance of each Standing Committee shall be until the 31st day of October in the year following the appointment of the Committee.

Sub-Committees. 15.—The Committees appointed by the Council may appoint Sub-Committees for purposes to be specified by the Committee. The references to Sub-Committees shall be explicit and shall not include any powers delegated to the Committee by the Council.

No Sub-Committee shall report direct to the Council.

The Chairman of any Committee shall be ex-officio a member of all its Sub-Committees.

16.—The quorums of each Standing Committee shall be five, with the exception of the Finance and General Purposes Committee and the Air Raid Precautions Committee, in which cases the quorums shall be six, and the Education Committee, in which case the quorum shall be eight.

17.—The Council may appoint Special Committees for such purposes as it may from time to time consider expedient.

18.—Each Committee shall report the result of its deliberations in writing to the Council and shall not, without the previous approval of the Council, take action save in respect of delegated powers in which case the action taken shall be reported to the Council.

19.—Each Standing Committee shall have power to authorise the expenditure of a sum not exceeding £20 (in the case of the Education Committee, £100) at any one meeting without the previous sanction of the Council, provided the same be carried by a majority of the whole number of the Committee.

PROCEDURE AT MEETINGS.

20.—The Standing Orders of the Council as to rules of debate at Council Meetings, shall *mutatis mutandis* apply to Committee and Sub-Committee Meetings (including meetings of the Council in Committee) except those Standing Orders which relate to standing and to speaking more than once.

21.—The order of business at every meeting of the Council shall be as follows:—

- (1) Business expressly required by Statute or otherwise to be done.
- (2) The Minutes of the last meeting to be read for confirmation, unless a printed copy of such minutes has been previously sent to each member of the Council when they shall be taken as read.
- (3) Official announcements.
- (4) Deputations.
- (5) Business specially brought forward by the Mayor or Chairman.
- (6) Memorials.
- (7) Questions.
- (8) Business remaining from last meeting (if any).
- (9) Reports of Committees.
- (10) Reports of Officers.
- (11) Motions of which notice has been given in the order in which they have been received.
- (12) Any other business on the Agenda Paper;

but the Council may nevertheless by a vote direct the order of precedence to be changed.

Committees' Reports. 22.—The Chairman or other Member having charge of the Report of a Committee shall submit to the Council a motion for the reception thereof.

Notice of Question.

In default of such motion being so submitted any other Member may submit the same; and on the consideration of such report any Member may put a question to the Chairman of the Committee with reference to any matter upon the report, giving the Chairman, where practicable, notice of the intention to put such question, but no question can be put to the Chairman with reference to any matter within the province of the Committee which does not appear upon the report, unless written notice thereof has been given to the Town Clerk not later than 12 o'clock noon two days previous to the meeting of the Council. No discussion shall be permitted in relation to any question or the reply thereto.

Deputations. 23.—

(a) Committees may receive deputations on matters within their orders of reference, provided that a memorial in writing setting out the reasons why the deputation wishes to attend, shall first have been submitted.

Deputations shall only be received by the Council upon the recommendation of the Committee concerned and where the Committee so recommend the Town Clerk shall invite the deputation to attend at the next meeting of the Council.

(b) If the matter in question solely concerns any particular Ward, the members of the Council for that Ward shall be invited to attend the Committee meeting at which the Memorial is to be considered or the deputation received.

(c) A deputation shall not exceed 4 in number, of whom not more than one shall be a non-resident of the Borough, and only two Members thereof shall be permitted to address the Council, or Committee as the case may be, except in reply to questions from Members of the Council or of the Committee. Each speech inclusive of the reading of the Memorial shall not be of more than ten minutes duration. After such address the deputation shall withdraw and the Council or Committee as the case may be, shall then proceed to deliberate.

Notices of Motion.

24.—A notice of motion shall be in writing signed by the Member giving the same. It shall be delivered at the Town Clerk's Office five clear days at least before the meeting of the Council at which it is intended to be moved, and all such notices shall be entered in the order in which they are received in a book to be kept by the Town Clerk in his office.

The Town Clerk shall insert in the summons for any meeting of the Council all notices of motion duly given in the order in which they have been received.

25.—No motion shall be made (otherwise than by way of amendment) unless notice thereof appears on the Agenda paper, or unless it shall arise out of a report or other document before the meeting or in cases which a majority of the members present and voting shall resolve to be urgent.

Notice of Motion except in certain cases to appear on Agenda.

26.—If a motion, notice of which is specified in the summons, be not moved by the Member who has given the notice, or by some other Member duly authorised in writing on his behalf, when it comes on in due course it shall, unless postponed by leave of the Council, be considered as dropped, and shall not be moved without fresh notice, unless it be business which by law the Council must transact.

Motions not moved considered as dropped.

27.—Except on a report of a Committee of the Council, no motion to rescind any resolution which has been passed within the preceding six months nor any motion to the same effect as any motion which has been negatived within the preceding six months shall be in order, unless the notice thereof shall have been given and specified in the summons and the notice shall bear in addition to the name of the Member who proposes the motion, the names of two other Members and when any such motion has been disposed of by the Council it shall not be competent for any Member to propose a similar motion within a further period of six months.

Negatived Motions.

28.—At any meeting of the Council all amendments to motions shall, if required by the Mayor or Chairman be reduced to writing signed by the mover and delivered to the Town Clerk immediately on their being seconded; and after having been seconded the same shall not be withdrawn without leave of the Council. Every original motion shall, if required by the Mayor or Chairman be read by the mover before being spoken upon and no motion or amendment shall be spoken upon, except by the mover, until it has been seconded.

Motions and Amendments.

If the mover of an original motion or of an amendment sit down without speaking upon it, he shall lose the right of addressing the meeting thereon.

Loss of right to address meeting.

A Member seconding a motion or amendment may reserve the right to speak at a subsequent period of the debate.

Reservation of right to speak.

No Member shall be allowed to speak more than once on the same question unless permission be given to explain, or the attention of the Chair be called to a point of order.

Members to speak only once.

Right of
reply.

The mover of every original motion, but not of any amendment—except when such amendment becomes the substantive motion, and then its mover—shall have the right of reply, immediately after which the question shall be put from the chair.

Amend-
ments
(generally).

No second amendment shall be received until the first has been disposed of. If the first amendment be lost another may be proposed, if the second be lost then another, and so on. If any amendment be carried it shall displace the original motion, shall form a substantive motion and shall be open to amendment in the same way. If no further amendment be proposed it shall be put to

Substantive
motion.

the meeting as a substantive motion and adopted or rejected, as the case may be. All amendments must be relevant to the motion and no Member shall move more than one amendment to the same motion.

Leave to
withdraw
any portion
of
Committee's
report.

The mover of a motion to approve the proceedings of a Committee of the Council shall, at any stage of the proceedings in relation to such motion, be at liberty to apply to the Council for leave to withdraw any portion of the report of such proceedings. No Member speaking in relation to such application shall be allowed to speak for a longer period than three minutes.

Motion "To
proceed to
next busi-
ness" or
"To
Adjourn."

29.—Any Member who has not spoken on the question before the Council may move: "That the Council proceed to the next business" or "That the Council do now adjourn," on the seconding of which the Mayor or Chairman shall, without discussion immediately put the question to the vote. No speech shall be made by the mover or seconder.

Second
Motion for
Adjourn-
ment.

30.—A second motion "That the Council do now adjourn" or "That the Council do now proceed to the next business" shall not be made pending the consideration of the business then under discussion within a period of one hour, unless it be proposed by the Mayor or Chairman.

The Closure.

31.—Any Member who has not spoken on the question before the Council may, at the close of any speech, move "That the question be now put." This motion must be seconded by a Member who has not exhausted his right to speak. When an amendment is under discussion the motion shall apply only to that amendment. The motion must be moved and seconded without a speech and the Mayor or Chairman shall forthwith put the motion to the meeting. If the motion "That the question be now put" be carried, the Mayor or Chairman shall, subject only to the right of reply given by Standing Order 28, put the question to the vote without further debate.

32.—Members of the Council shall stand when speaking and shall speak of each other in the Council, during the transaction of business, by their respective titles of “Mr. Mayor,” “Mr. Deputy Mayor,” “Alderman,” or “Councillor,” as the case may be. Members to address the Chair standing.

33.—A Member moving a motion shall not be allowed to speak on such motion for a longer period than ten minutes, and any other Member speaking to any motion or amendment shall not be allowed to speak for a longer period than five minutes, or in the case of a point of order, three minutes. Length of Speeches.

34.—A Member who speaks shall direct his speech strictly to the motion or amendment under discussion or to a motion or amendment to be proposed by himself, or to a question of order. Speeches to be relevant.

35.—No Member shall impute unworthy motives to or use offensive expressions concerning any other Member. In the event of any Member offending against this Order the Mayor or Chairman may call upon him to withdraw the offensive expression. Members not to impute unworthy motives.

36.—If any Member of the Council refuses to obey the repeated rulings of the Mayor or Chairman the Mayor or Chairman shall be empowered to “name” such offending Member, and may move (without any debate thereon) that the offending Member be suspended from the sitting of the Council, and if upon such motion being carried the offending Member fails to leave the Council Chamber, the Mayor or Chairman may take steps for the removal of the offending Member. Removal of Member from Chamber.

37.—Every Member shall remain seated with the exception of the one who may be addressing the Council and whenever the Mayor or Chairman rises no one shall continue standing, nor shall any Member rise until the Chair be resumed. Remainder to be seated when Chairman rises.

38.—The decision of the Mayor or Chairman on all questions of order shall be considered final, and if disorder should arise, the Mayor or Chairman, acting in his discretion as a matter of right, shall be at liberty to quit the Chair and announce the adjournment of the meeting, and upon his doing so the meeting shall be immediately adjourned. Disorder.

39.—All questions shall (except where by law it is otherwise provided) be determined by a show of hands, unless afterwards a formal division be demanded by three Members rising in their places, when the names of the Members shall be called over by the Town Clerk, who shall record and enter on the minutes those voting respectively for and against the question, those abstaining from voting and those absent from the meeting when the division was taken. Voting.

**Member's
dissent.**

Any Member who demands a division but who fails to get a sufficient number of other members to rise with him shall be entitled to have his name recorded as voting for or against the motion or amendment in respect of which a division is so demanded but otherwise no protest or expression of dissent shall be entered upon the minutes of the Council.

**Casting
Vote.**

40.—Every question at a meeting shall be decided by a majority of votes of the Members present and voting thereon, and in case of an equal division, the Mayor or Chairman shall have a second or casting vote.

**Suspension
of Business.**

41.—No business at any Council or Committee meeting shall be transacted after ten o'clock p.m.

MISCELLANEOUS.**Memorials.**

42.—Memorials to the Council shall be presented through a Member of the Council only. It shall be competent for any Member to move without comment the reception of a memorial and its reference to a Committee, but no discussion shall take place on the subject matter thereof.

**Estate
Book.**

43.—An estate book shall be kept in which all the properties of the Council shall be entered in detail.

**Corporate
Seal.**

44.—The corporate seal of the Council shall be kept in some safe place secured by two different locks. The Mayor shall have the custody of the key of one lock, and the Town Clerk shall have the custody of the key of the other.

**Regulations
for
Sealing.**

45.—In all cases in which the corporate seal of the Council is required to be affixed to any document, it shall be so sealed in pursuance of a resolution duly passed by the Council or one of its Committees.

All deeds, instruments and writings to which the corporate seal may be required shall also be signed by the Mayor and Town Clerk, who shall subscribe their names thereto after such sealing.

Seal Book.

46.—An entry of the sealing of every document to which the corporate seal shall be affixed shall be made by the Town Clerk in a book to be provided for the purpose.

**Custody and
inspection
of Deeds.**

47.—Except when otherwise ordered, all the books, papers, and other documents belonging to the Council shall be kept at the Offices of the Council, and shall, with the exception of those of a strictly confidential character, be open at all reasonable times to the inspection of Members. The minute book only shall also be open to inspection during office hours by any person paying rates

levied by the Council on payment to the Town Clerk of one shilling for each inspection. Any person not a Member of the Council but being a Ratepayer as aforesaid may have copies or extracts supplied from such minute book within a reasonable time, after demand in writing, at the rate of sixpence, to be paid to the Town Clerk for every hundred words or figures or fraction of a hundred words or figures, of such copies or extracts.

48.—When any improvement is intended to be made within the Borough at the expense of the Council, or the acceptance of any tender is proposed, the estimated cost of the improvement and the amount of the quotation or tender recommended for acceptance shall appear in the report of the Committee together with an intimation as to whether it is the lowest tender.

Estimate
and Tender
to appear
in Report.

49.—

Contracts.

(A) (1) Every contract made by the Council shall comply with these standing orders, and no exception from any of the following provisions of these standing orders shall be made otherwise than by direction of the appropriate Committee, which shall report to the Council any direction given in pursuance of this standing order.

To comply
with
Standing
Orders.

(2) Express note of any exception from any of the provisions of these standing orders and of the emergency if any by which the exception shall have been justified shall unless recorded in the printed report of a Committee which is laid before the Council be made in the minutes of the Council.

(B) Before the Council is recommended to enter into a contract, which exceeds £1,000 in value or amount, for the execution of any work the Committee concerned shall obtain from the appropriate officer or other person an estimate in writing of the probable expense of executing the work together with an estimate of the annual expenditure and income.

Report
before
recommending
Contract.

(C) No contract which exceeds £500 in value or amount for the supply of goods or materials or the execution of any work shall be made unless at least ten days' public notice (expressing the nature and purpose thereof, inviting tenders for its execution, and stating the last date when tenders will be received) has been given in one or more of the local newspapers circulating in the district and in the appropriate trade journals. Where the value or amount of the contract exceeds £1,000, such public notice shall only be given in one or more newspapers or journals circulating among such persons as undertake such contracts. This standing order shall not apply to work or materials which owing to the particular character thereof can only be efficiently carried out or supplied by certain persons or firms in which case the Committee concerned shall be authorised to invite tenders from selected persons or firms of known stability and specialised experience.

Advertisements.

Invitation
to tender.

Receipt of Tenders. (D) (1) Where in pursuance of standing order (C) public invitation to tender is required, every notice of such invitation shall state that no tender will be received except in a plain sealed envelope which may bear the word "Tender ——" followed by the subject to which it relates, but shall not bear any name or mark indicating the sender, and such envelopes shall remain in the custody of the Town Clerk until the time appointed for their opening. Provided that in relation to tenders for the consideration of the Education Committee references in this clause to the "Town Clerk" shall be read as the "Director of Education."

Opening of Tenders. (2) All tenders for any one contract shall be opened at one time and only in the presence of the Chairman of the Committee concerned or a Member of the Committee specially designated, and either the Head of the responsible Department or an Official of the Council designated by the Town Clerk. All tenders so opened shall be initialled and numbered by the Chairman or the Member referred to above.

Most favourable Tender. (E) A tender other than the lowest tender if payment is to be made by the Council or the highest tender if payment is to be received by the Council shall not be accepted until the Council shall have considered a written report from the appropriate officer or other person.

Contracts in writing. (F) Every contract which exceeds £200 in value or amount shall be in writing, and wherever the value or amount exceeds £500 a formal contract, in terms to be approved by the Town Clerk, shall be entered into.

Penalty and Surety. (G) Every contract which exceeds £500 in value or amount and is either for the execution of work or for the supply of goods or materials otherwise than at one time shall provide for a pecuniary penalty or a payment by way of liquidated damages to be paid by the contractor in case the terms of the contract are not duly performed; and the Council shall require and take sufficient security for the due performance of every contract for the execution of works, either by way of insurance policy, bankers guarantee or deposit of a sum certain, unless the appropriate officer, having regard to all the circumstances, considers it to be unnecessary.

Origin of goods. (H) All contracts shall, so far as practicable, require either that goods and materials used in their execution shall have been produced in the United Kingdom or that they shall have been produced in the British Empire.

British Standards Specification. (I) All contracts, where a specification issued by the British Standards Institution is current at the date of the tender and is appropriate, shall require that goods and materials used in their execution shall be in accordance with that specification.

(J) In every written contract a clause shall be inserted to secure that the Council shall be entitled to cancel the contract and to recover from the contractor the amount of any loss resulting from such cancellation, if the contractor shall have offered or given or agreed to give to any person any gift or consideration of any kind as an inducement or reward for doing or forbearing to do or for having done or forborne to do any action in relation to the obtaining or execution of the contract or any other contract with the Council, or for showing or forbearing to show favour or disfavour to any person in relation to the contract or any other contract with the Council, or if the like acts shall have been done by any person employed by him or acting on his behalf (whether with or without the knowledge of the contractor), or if in relation to any contract with the Council the contractor or any person employed by him or acting on his behalf shall have committed any offence under the Prevention of Corruption Acts, 1889 to 1916, or shall have given any fee or reward the receipt of which is an offence under sub-section (2) of section 123 of the Local Government Act, 1933.

(K) In every written contract for the execution of work or the supply of goods or materials the following clauses shall be inserted:—

- (1) The contractor shall in the execution of this contract pay rates of wages and observe hours of labour not less favourable than those commonly recognised by employers and trade societies (or, in the absence of such recognised wages and hours, those which in practice prevail amongst good employers) in the trade in the district where the work is carried out. Where there are no such wages and hours recognised or prevailing in the district, those recognised or prevailing in the nearest district in which the general industrial circumstances are similar shall be adopted. Further, the conditions of employment generally accepted in the district in the trade concerned shall be taken into account in considering how far the terms of this clause are being observed. The contractor shall be prohibited from transferring or assigning or sub-letting, directly or indirectly, to any person or persons whatever, any portion of his contract without the written permission of the Council. Where rates of wages and hours and/or conditions of labour are contained in awards in respect of the district where the work is carried out issued by duly recognised Wages or Conciliation Boards such rates, hours and conditions shall be deemed to be those commonly recognised as aforesaid.
- (2) The contractor and all sub-contractors shall keep proper wages and time books showing the

wages paid to and the time worked by the work-people in his employment in and about the execution of this contract and such wages and time books shall be produced whenever required for the inspection of any officer authorised by the Council or any duly authorised officer of the Government.

- (3) Should the Council have reasonable grounds for believing that the above conditions are not being complied with, the contractor and sub-contractors shall be required to produce proof (to the satisfaction of the Council) of their compliance with the said conditions.
- (4) The contractor shall be responsible for the observance of the above clauses by the sub-contractors.
- (5) In the event of failure to comply with the conditions regarding rates, hours or conditions of labour or assigning or sub-letting portions of the contract it shall be within the power of the Council, at its option, either to cancel the contract or to call upon the contractor to pay to the Council, as and for liquidated damages, a sum of 20/- per employee for each and every case in which such failure shall be proved to the satisfaction of the Council.
- (6) The Council will not accept or be under any financial responsibility to any person or persons to whom the contract may be sub-let.

Interest in Contracts.

50.—A Member who has a pecuniary interest in a contract, a proposed contract or other matter which comes under consideration at a meeting of the Council or a Committee shall retire if he is requested to do so either by the Mayor or Chairman or by a majority of the other Members present.

Suspension of Standing Orders.

51.—Any one or more of the standing orders may, upon motion made on a notice duly given, or in any case of urgency with the sanction of the Mayor or Chairman be suspended at any meeting so far as regards any business at such meeting provided that the motion be carried by a majority of the Council present and voting.

**Standing Orders—
Motions to Rescind,
etc.**

52.—No standing order, amendment or repeal thereof, shall be considered at any meeting, unless notice thereof shall have been given in the summons for such meeting.

Instructions to Committees.

53.—The Committees shall observe the instructions contained in Appendix "A" hereto.

APPENDIX "A."

INSTRUCTIONS TO COMMITTEES.

GENERAL.

Staff Appointments, etc. 1.—Each Committee shall consider and report to the Finance and General Purposes Committee upon the appointment and dismissal of those officers (except Chief Officers) whose work falls wholly or mainly within the province of the Committee:

Vacancies. Provided that a Committee shall have power to fill a vacancy in any office the terms of appointment to which have been approved by the Council, and may subject to any special requirements of the Council, delegate such power to such Members or Officers of the Council as the Committee may from time to time decide.

Advertisements. Advertisements inviting applications for vacancies shall stipulate that canvassing or submitting a testimonial from any Member of the Council will be deemed a disqualification.

Expenditure on Capital Account. 2.—Committees shall not spend money on capital works, even when authorised by the Council, until such works are approved (if necessary) by the appropriate Statutory Authority; and where financed by way of loan, until after the receipt of the sanction to borrow; nor shall any such works be financed out of revenue except by express leave of the Council.

Committee Estimates. 3.—To furnish to the Finance and General Purposes Committee in the month of February of each year and in any other month that may be prescribed by such Committee estimates of their income and expenditure, and likewise to furnish the Finance and General Purposes Committee with all such detailed statements as may be necessary to show how the estimates of each Department are made up.

Limit on expenditure. 4.—To confine their expenditure within the estimates finally approved by the Council and not to exceed except in case of emergency the amount provided in the yearly estimate, until the matter has been submitted to the Finance and General Purposes Committee of the Council and approved by the Council.

Maintenance of properties. 5.—To authorise the maintenance and repair of properties under their control.

6.—To report to the Finance and General Purposes Committee on all items affecting the income of the Council.

7.—To cause plans and estimates to be prepared when in their opinion necessary, and to obtain tenders for the performance of any works that may be required.

8.—To submit to the Finance and General Purposes Committee of the Council, prior to submission to the Council, full information and particulars of any scheme or any additions to or modifications thereof involving expenditure which has not already received the express sanction of the Council, in order that the said Committee may consider and recommend to the Council whether (having regard to the financial obligations of the Council) the proposed expenditure should be approved.

9.—Where an estimate for specific purposes has been approved by the Council, the sum so allocated shall not be appropriated for any other purpose unless and until the same has been submitted to and approved by the Council.

EDUCATION COMMITTEE.

Subject to the provisions of the Scheme made by the Council, and approved by the Board of Education (Appendix "B"), to the Standing Orders of the Council, and to such Instructions to the Committees as the Council may from time to time adopt and subject as hereinafter provided:—

1.—To exercise the powers and duties of the Council as the Local Education Authority for the Borough of Hendon.

2.—To observe the "General Instructions to Committees."

3.—To keep their accounts in such form as shall be necessary for Government audit and returns, and as may from time to time be prescribed by the Committee, and submit the same each month to the Finance and General Purposes Committee of the Council.

4.—The Council expressly reserves to itself the following powers:—

Appointing and fixing the salaries and/or conditions of employment of the Director of Education and other Officers, except Teachers and Caretakers.

WORKS AND FIRE BRIGADE COMMITTEE.

To consider and report on all questions relating to:—

Works, etc.

1.—Sewerage and drainage (except the consideration of plans for the sewerage and drainage of building estates and the drainage of buildings).

2.—The collection and disposal of house and trade refuse and the maintenance of Refuse Destructor Works.

3.—The acquisition of the Council's plant, equipment and horses, and the maintenance of the Town Hall and Depôts.

4.—The construction and maintenance of Swimming Baths, Public Slipper Baths and Sanitary Conveniences.

5.—The purchase of all necessary materials and goods for the maintenance and repair of the Council's properties, except in respect of Housing Estates.

Fire Brigade.

6.—The Fire Brigade and all buildings and apparatus in connection therewith.

7.—Fire protection.

8.—Water pressures.

9.—Air raid fire precautions under the Air Raid Precautions Act, 1937.

10.—The issue of licences under the Petroleum (Consolidation) Act, 1928, or under any Order-in-Council made thereunder.

LIBRARIES AND LOCAL PENSIONS COMMITTEE.

To carry out the duties imposed upon the Council by the Old Age Pensions Act, 1936, and the Blind Persons Act, 1938.

To consider and report on all questions relating to the provision, equipment and maintenance of the Central Library and Branch Libraries and all matters appertaining thereto.

PUBLIC HEALTH AND MEDICAL SERVICES COMMITTEE.

To exercise and carry out the powers and duties of the Council:—

1.—In all matters of urgency relating to the suppression of nuisances and the preservation of public health.

2.—On any official representations made under Section 11 of the Housing Act, 1936, except the making of demolition orders upon which the Committee shall report to the Council.

3.—Under the Diseases of Animals Acts and Orders.

To consider and report on all questions relating to:—

Public Health, etc.

4.—Public health and sanitation—Public Health Acts.

5.—Notification, control and treatment of infectious diseases.

6.—The abatement of overcrowding, repair and sanitary condition of houses—Housing Acts.

7.—The provision and maintenance of hospitals.

8.—Health and welfare in factories—Factories Acts.

9.—Sanitary conveniences and washing facilities, temperatures and ventilation—Shops Acts.

10.—Administration of the Milk and Dairies Acts and Orders.

11.—The Mortuary.

Medical Services.

12.—The administration of the Maternity and Child Welfare Act, 1918, and any Act or Acts extending or amending the same and any Order made in pursuance thereof.

13.—The provision and maintenance of all Health Centres.

14.—The administration of the Midwives Acts.

15.—Notification of births and child life protection (Pt. VII.—Public Health Act, 1936).

16.—The administration of delegated powers (by the County Council) relating to nursing homes. (Pt. VI.—Public Health Act, 1936).

17.—School Medical Services, and to report direct to the Education Committee thereon.

18.—Medical inspection, ophthalmic and dental treatment of pupils in secondary schools by arrangement with the County Council.

ESTATES, PARKS AND ALLOTMENTS COMMITTEE.

To consider and report on all questions relating to:—

Estates and Parks, etc.

1.—The acquisition, control, maintenance and development of Parks, Open Spaces, Recreation Grounds, Public Walks, and Pleasure Grounds.

2.—The provision, planting, maintenance and removal of trees in and from highways and streets and properties adjoining thereto, and the formation and maintenance of greens and gardens forming parts of highways and streets;

Provided that this reference shall not apply to the removal of trees necessary for the proper maintenance of a highway or required owing to any highway improvement scheme proposed by the Highways Committee.

Allotments.

3.—The provision and maintenance of allotments.

HIGHWAYS COMMITTEE.

To consider and report on all questions relating to:—

1.—The charge, maintenance and lighting of all Roads.

2.—Street improvement works and the dedication of private streets.

3.—Passenger transport services, and telegraphs and telephones in or adjoining highways.

4.—Encroachments on highways.

5.—Signs on and adjoining highways.

6.—Public footpaths.

7.—Accidents on highways.

8.—The approval of sites for the planting of trees, and for the formation of greenswards and gardens in highways and streets.

9.—Street Trading (Part VII. Hendon Urban District Council Act, 1929).

HOUSING COMMITTEE.

To consider and report on all questions relating to the provision of houses for the working classes and the maintenance and management of the Council's Housing Estates.

RATING AND VALUATION.

1.—*To consider and make recommendations to the Council upon all matters falling to be dealt with under the Rating and Valuation Act, 1925, and any Acts amending the same and all Statutory Orders and Rules made thereunder, other than the making of a Rate or the raising of a loan.*

2.—*To exercise and carry out without confirmation the powers and duties of the Council under such Acts, Orders and Rules in so far as they relate to the following matters of urgency:—*

(a) The valuation of all rateable property,

(b) The preparation, making and revision of valuation lists, including draft valuation lists.

- (c) Appearance in the hearing of objections or appeals against valuations included in the valuation list or draft valuation lists.
- (d) The issue and collection of all necessary notices, particulars and returns and the certification of all necessary documents under the hand of the Chief Valuation Officer unless in the case of any special matter they shall require any such notice, return or document to be authenticated by the signature of the Town Clerk.
- (e) Any other matters wherein delay would be prejudicial to the interests of the Rating Authority.

To report to the next meeting of the Council their acts and proceedings relative to such matters of urgency.

BUILDINGS AND TOWN PLANNING COMMITTEE.

To exercise the powers and duties of the Council relative to:—

- 1.—Plans for new streets and buildings.
- 2.—Town planning, in so far as the powers concern—
 - (i) approval to applications in order under the Planning Schemes, and
 - (ii) notices of refusal of consent.
- 3.—Restriction of Ribbon Development Act, 1935, in so far as the powers concern—
 - (i) the granting or otherwise of consents under Sections 1 and 2 of the Act, and
 - (ii) the provision of means of entrance and egress, etc., as a condition of the approval of building plans, Section 17 of the Act.

To consider and report on all questions relating to:—

- 4.—The making of Byelaws as to New Streets and Buildings.
 - 5.—Town planning, subject to No. 2 above, and the acquisition of land required for the purposes of the Planning Schemes.
 - 6.—Restriction of ribbon development, subject to No. 3 above.
 - 7.—Temporary buildings.
 - 8.—The naming of streets and numbering of houses therein.
-

AIR RAID PRECAUTIONS COMMITTEE.

To consider and report on all matters within the scope of the Air Raid Precautions Act, 1937 (except air raid fire precautions), with power to act in the event of a state of emergency arising.

FINANCE AND GENERAL PURPOSES COMMITTEE:

(a) Finance.

1.—To appoint a Rota of Members to deal with the passing of accounts and examination of statements, and where any such appear to require re-consideration to re-submit the same to the Committee affected, giving the reasons for so doing.

2.—To recommend the making of orders in writing on the Borough Treasurer for payment of moneys resolved by the Council to be paid, such orders to be signed by three members of the Council, being members of the Finance Committee, and countersigned by the Town Clerk.

Similar orders in writing on the Borough Treasurer may be authorised by the Mayor in respect of urgent payments but shall be reported at the next meeting of the Council.

3.—To obtain all necessary sanctions to loans and to negotiate all loans authorised by the Council to be provided. To recommend from time to time such arrangements for repayment of such loans as may be found desirable.

4.—To recommend to the Council the investment of all Funds under the control of the Council as and when necessary.

5.—To prepare and submit to the Council the estimates of income and expenditure for each year, together with supplementary information in relation to general rate and other funds of the Council, and to recommend from time to time the rates to be made by the Council.

6.—To manage and transact all matters relating to the preparation and collection of the rates made, assessed and levied by the Council.

7.—To confer with the several Committees and from time to time to effect all necessary insurances.

8.—Generally to have charge of the Finance Department and the accounts and funds of the Council, and to effect and control the Banking arrangements of the Council.

9.—To have charge of the Stationery Department and cause the printing and stationery required for the ordinary use of the various Departments to be supplied and executed by contract or otherwise.

10.—To make recommendations to the Council as to the management of any Stock or Loans issue and to take all necessary steps in connection therewith.

11.—To render and collect all accounts of the Council (in whatever capacity acting), to recommend the entering of and direct such proceedings as may be deemed requisite for enforcing the payment of any such accounts and to recommend to the Council the making of any such allowances or deductions from accounts owing as the Committee may deem fit.

12.—To receive from the several Committees of the Council full information and particulars of any matters with financial implications not sanctioned by the Council, and thereon to consider and report whether, having regard to the financial obligations of the Council, such matters should be approved.

13.—To consider and report to the Council generally upon all or any matters having financial implications.

14.—Whenever an appointment of an Officer is made to report to the Council the amount of security, if any, they recommend should be provided in respect of such Officer.

15.—To recommend to the Council the issue of all licences under Section 27 of the Local Government Act, 1894, other than licences under the Petroleum (Consolidation) Act, 1928, or any Acts amending the same or under any Order-in-Council made thereunder.

16.—To control all lettings of Council property other than of Schools and of Houses for the Working Classes.

17.—To recommend to the Council all advances under the Small Dwellings Acquisition Acts and take all necessary steps in connection therewith.

(b) General Purposes.

18.—To consider and report upon the terms of appointment, salaries, duties, promotion and general arrangement of Council's permanent staff (other than of Teachers and Caretakers appointed by the Education Committee).

19.—To watch all Bills in Parliament affecting the Borough and all applications for Provisional Orders and to recommend to the Council any necessary action.

20.—To consider and report upon all legal proceedings instituted against the Council and all proceedings instituted by the Council on the recommendation of any other Committee in any Court other than the Police Court or the County Court.

21.—To prepare, when necessary, Standing Orders for regulating the proceedings of the Council and its Committees, and to submit the same to the Council for approval.

22.—To attend to all business of a general character not entrusted to any other Committee and to suggest to the Council from time to time any new business which in its opinion is important in the public interest.

APPENDIX "B."

EDUCATION COMMITTEE.

SCHEME made by the URBAN DISTRICT COUNCIL OF HENDON for the constitution of an EDUCATION COMMITTEE, under Section 4, Sub-Section 3 of the Education Act, 1921.

1.—One Education Committee (hereinafter called "the Committee") shall be established by the Urban District Council of Hendon (hereinafter called "the Council") in accordance with this scheme (a) for the purpose of supplying or aiding the supply of Education other than Elementary, and (b) with respect to Elementary Education.

2.—The Committee shall, when completed, consist of twenty-three Members appointed by the Council, including persons of experience in Education and persons acquainted with the needs of the various kinds of Schools in the District being:—

Eighteen Members of the Council.

Five Members appointed by the Council from outside that body and being persons of experience in Education and acquainted with the needs of the various kinds of Schools in the District.

Provided that the interests of Secondary Education, both of Boys and Girls, Technical Education and Commercial and Industrial Education, having special regard to the Industries of the District, Elementary Education in Council Schools and in the various classes of Voluntary Schools shall always be represented on the Committee.

If such representation is not secured by the Members appointed from the Council, it shall be secured by means of Members appointed from outside their body, and if it appears desirable to the Council after consultation with persons or bodies representative of the type of Education concerned.

Provided further that two Members of the Committee shall always be Women.

3.—The term of office of Members of the Committee shall be one year.

4.—Any Member who is incapacitated from acting or who communicates in writing to the Committee a desire to resign or who is absent from all the meetings of the Committee during a period of six months (except for some reason approved by the Committee) or who being, when appointed, a Member of the Council, ceases to be a Member of the Council, or not being a Member of the Council, becomes a Member of the Council shall thereupon cease to be a Member of the Committee.

5.—Members appointed to fill casual vacancies shall be appointed only for the remainder of the term of office of the outgoing Member and subject to the same provisions as regulated the appointment of that Member.

6.—The first appointment of an Education Committee under this Scheme shall be made by the Council on the 28th day of April immediately following the approval of this Scheme by the Board of Education. The persons who are Members of the Education Committee at the date of such approval shall continue in office until the date of such appointment.

7.—The Scheme for the constitution of an Education Committee for the Urban District of Hendon made by the Council on the 12th March, 1928, approved by the Board of Education on the 12th April, 1928, is hereby revoked.

The foregoing Scheme was made by the Council at a meeting held on the 16th day of December, 1929.

THE COMMON SEAL of the URBAN
DISTRICT COUNCIL OF HENDON
was hereunto affixed this 24th day of
January, 1930, in the presence of:—

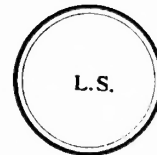

E. HOLT, *Chairman.*

LEONARD WORDEN, *Clerk.*

Approved by the Board of Education
this 27th day of February, 1930.

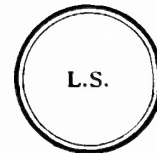

W. RITCHIE,

Authorised under the Board of Education Act, 1899.

APPENDIX

TO

Report of Finance and General Purposes Committee,

1st May, 1939.

Page	
1/2.	Statement of Receipts and Payments.
3.	Statement of Bank Accounts and Balances.
4.	Rate Collection Account and Comparative Statement.
4.	Statement of Rateable Values.
5/6.	Expenditure and Income on Rate Fund Accounts.
7.	Accounts Examined and Approved.
7.	Requisitions submitted to Committees.
	Statistical Returns:—
8.	Education Services.
8.	School Medical Services.
9.	Maternity and Child Welfare Services.
9.	Hendon Borough (Nursing Associations) Scheme, 1935.
10.	General Health Statistics.
11.	Fire Brigade and Ambulance.
11.	Refuse Destructor.
11.	Small Dwellings Acquisition Acts.
12.	Housing Statistics.
13/14.	Library Statistics.
15.	Public Parks.
15.	Public Lavatories.
15.	Public Slipper Baths.
16.	Open Air Swimming Baths.
17.	Wages Return.
18.	Loan Debt Statement.
19.	Loan Sanctions.
19/21.	Payments to Contractors under Engineer's Certificates.
22/26.	Contracts, etc. let.

(1)

1.—RECEIPTS AND
1st April, 1938

RECEIPTS.	Receipts now Reported.		Receipts Previously Reported.		Total to 31/3/39.	
	£	s. d.	£	s. d.	£	s. d.
Revenue Accounts (General).....	66423	6 3	1227009	7 11	1294332	14 2
Private Street Improvements	3585	5 8	26064	3 7	29649	0 3
	70008	11 11	1253073	11 6	1323082	3 5
Elementary Education Accounts	23539	17 2				
Higher Education Accounts	600	9 10				
Juvenile Organisation Accounts	3	15 11				
	24144	2 11	215043	12 4	239157	15 3
Capital Accounts (General)	81070	17 2				
Capital Accounts (Education)	47230	0 0				
	128300	17 2	197967	19 0	326268	16 2
Small Dwellings Act Accounts	650	9 5	16423	13 0	17074	2 5
Superannuation Fund Accounts	4679	18 2	14788	15 8	19468	13 10
Loans Pool Account	120261	8 7	257812	5 4	378073	13 11
Receipts 1938/39 Accounts	£348045	8 2	1956009	16 10	2304055	5 0
ARREARS—1937/38.						
Revenue Accounts (General).....	2243	10 8	31744	19 6	33988	10 2
Private Street Improvements	—	—	—	—	—	—
Elementary Education Accounts	33	11 3				
Higher Education Accounts	—	—				
Juvenile Organisation Accounts	—	—				
	33	11 3	5804	11 5	5838	2 8
Capital Accounts (General)	75	0 0				
Capital Accounts (Education)	—	—				
	75	0 0	2117	0 0	2192	0 0
Small Dwellings Act Accounts	—	—	—	—	—	—
Superannuation Fund Accounts	—	—	463	4 2	463	4 2
Loans Pool Account	—	—	—	—	—	—
Receipts 1937/38 Accounts	£2352	1 11	40129	15 1	42481	17 0
TOTAL RECEIPTS	£350397	10 1	1996139	11 11	2346537	2 0
Cancelled Cheques:—						
Cash Book folio 32				2	18	0
Cash Book folio 127				159	9	6
Cash Book folio 147					19	6
Cash Book folio 162				4	19	10
Cash Book folio 181				985	8	9
					1153	15 7
					665	15 4
Cheques not issued						
Nett Balance in Hand, 1st April, 1938:—						
Per General Cash Book folio 11			108761	14	11	
Per Loans Pool Cash Book folio 2			10925	1	11	
					119686	16 10
					£2468043	9 9

RECEIPTS AND
 April, 1939

Total
 to
 31/3/39.
 £ s. d.
 294322 14 2
 29649 9 3
 293082 3 5

239157 15 3

226268 16 2
 17074 2 3
 19468 13 10
 375073 13 11
 304055 5 6

33988 10 2

5838 2 3

2192 0 0

463 4 2

42481 17 0

46337 2 0

1153 15 7
 667 15 4

9686 16 10

8043 9 9

PAYMENTS ACCOUNT.

—31st March, 1939.

	Payments		Payments		Total	
	now		Previously		to	
	Reported.		Reported.		31/3/39.	
	£	s. d.	£	s. d.	£	s. d.
PAYMENTS.						
Revenue Accounts (General).....	111124	11 6	1109155	1 9	1310279	13 3
Private Street Improvements.....	11352	4 2	32823	6 9	44175	10 11
	122476	15 8	1231978	8 6	1354455	4 2
Elementary Education Accounts	37397	4 2				
Higher Education Accounts	2051	19 6				
Juvenile Organisation Accounts	389	15 4				
	39838	19 0	193333	4 5	233172	3 5
Capital Accounts (General)	75284	3 10				
Capital Accounts (Education)	46402	15 3				
	121776	19 1	221801	14 9	343578	13 10
Small Dwellings Act Accounts	2767	19 3	10938	13 1	13706	12 4
Superannuation Fund Accounts	485	0 2	7794	5 0	8279	5 2
Loans Pool Account	152038	6 1	207284	14 1	359323	0 2
Payments 1938/39 Accounts	£439383	19 3	1873130	19 10	2312514	19 1
CREDITORS—1937/38.						
Revenue Accounts (General).....			27674	7 0	27674	7 0
Private Street Improvements			1105	18 7	1105	18 7
			28780	5 7	28780	5 7
Elementary Education Accounts						
Higher Education Accounts						
Juvenile Organisation Accounts						
			4613	5 9	4613	5 9
Capital Accounts (General)						
Capital Accounts (Education)			3738	1 10	3738	1 10
Small Dwellings Act Accounts			36	2 7	36	2 7
Superannuation Fund Accounts			71	9 0	71	9 0
Loans Pool Account						
Payments 1937/38 Accounts			£37239	4 9	37239	4 9
TOTAL PAYMENTS	£439383	19 3	1910370	4 7	2349754	3 10
Cheques written back:—					1913	1 9
General Cash Book folio 11						

Nett Balance in Hand, 31st March, 1939:—
 Per Bank Account page 3

116576 4 2
 £2468043 9 9

2.—BANK ACCOUNTS AND BALANCES:

(3)

RECEIPTS.				PAYMENTS.			
1st April, 1938, to 31st March, 1939.				1st April, 1938, to 31st March, 1939.			
Balances, 28th February, 1939.		Receipts now reported, (Page 1).		Payments now reported, (Page 2).		Balances, 31st March, 1939.	
In Hand.	Overdrawn.	Transfers In.	Total.	Transfers Out.	In Hand.	Overdrawn.	Total.
£ s. d.	£ s. d.	£ s. d.	£ s. d.	£ s. d.	£ s. d.	£ s. d.	£ s. d.
107599 5 10	— — —	— — —	72252 2 7	3325 6 10	55550 19 2	— — —	181353 1 8
22580 7 0	149 10 10	— — —	24177 14 2	— — —	6988 13 0	— — —	46827 12 0
7304 8 7	— — —	— — —	128375 17 2	— — —	13903 6 8	— — —	135680 5 9
4828 15 8	— — —	— — —	650 9 5	— — —	2711 5 10	— — —	5479 5 1
10288 18 1	— — —	— — —	4679 18 2	— — —	14483 16 1	— — —	14968 16 3
152521 15 2	1651 4 1	— — —	230136 1 6	3325 6 10	93638 0 9	— — —	384309 0 9
51189 14 1	— — —	3325 6 10	129261 8 7	— — —	22788 3 5	— — —	174776 9 6
4293711 9 3	1651 4 1	3325 6 10	350397 10 1	430383 19 3	116376 4 2	— — —	559085 10 3
				ACCOUNT.			
				Revenue A/cs (General)	— — —	— — —	— — —
				Revenue A/cs (Education)	— — —	— — —	— — —
				Capital A/cs	— — —	— — —	— — —
				Small Dwellings Act A/cs	— — —	— — —	— — —
				Superannuation Fund A/cs	— — —	— — —	— — —
				Loans Pool A/c	— — —	— — —	— — —
				Totals	— — —	— — —	— — —

BANK RECONCILIATION ACCOUNT.		
Balance Per Bank Certificate—31st March, 1939	£	s. d.
Balance Per Bank Certificate—31st March, 1939	188290	1 9
Deduct:—	£	s. d.
Wages and Urgent Payments Account	3822	6 6
Less:—		
Returned Cheques Account	222	19 2
	3599	7 4
Less Unpresented Cheques	184690	14 5
	75215	12 9
Add In Hands of Cashier	109475	1 8
	6901	2 6
Balance as above	116376	4 2

(4)

RATE AND COSTS COLLECTION ACCOUNT—YEAR ENDING 31st MARCH, 1939:
(Twelve Months to 31st March, 1939.)

Debits.	£	s.	d.	Credits.	£	s.	d.
Arrears of Rates, 31st March, 1938	9818	6	4	Cash Collected to 31st March, 1939:—			
Rate made 4th April, 1938, at 10/6d. in the £	989808	15	0	Previously Reported	968277	5	10
Government Contribution in lieu of Rates	16328	0	6	Now Reported:—			
Supplementals, to 31st March, 1939	17488	2	3	Arrears and Costs	163	12	2
Rates Costs:—	£	s.	d.	Current Rates	13764	9	2
Arrears	230	11	10				13928 1 4
Current	1324	3	6				982205 7 2
			1554 15 4	Balances Due:—			
				Arrears and Costs	2124	13	1
				Current Rates (subject to allowances)	50667	19	2
							52792 12 3
							£1034997 19 5
							£1034997 19 5

Percentages Collected (Including Costs).

Previously Reported	93.66%
Now Reported	1.35%
Percentage of Total Debit	94.90%

RATE COLLECTION—COMPARATIVE STATEMENT.

As At	General Rate Collected.		General Rate 1936-37		General Rate 1937-38		General Rate 1938-39	
	1934-35	1935-36	Collected	Percentage	Collected.	Percentage	Collected	Percentage
	£	£	£		£		£	
30th April	7,106	18,592	9,266	1.02	25,435	2.69	37,154	3.65
31st May	114,412	126,267	142,920	15.65	145,728	15.39	169,034	16.62
30th June	214,453	266,131	291,597	31.89	392,362	31.91	316,287	31.93
31st July	327,366	353,556	303,745	40.36	422,860	44.62	445,493	43.67
31st August	341,157	368,333	418,227	46.16	442,316	49.59	475,830	46.52
30th September ..	362,012	385,990	436,560	47.59	458,989	48.07	488,254	47.65
31st October	366,997	447,596	501,552	54.18	544,446	56.97	586,148	57.20
30th November ..	504,124	556,327	622,737	67.27	615,147	62.31	660,419	67.1
31st December ..	590,143	633,907	731,462	78.36	765,032	79.29	816,788	79.2 3
31st January	704,531	756,094	845,454	90.76	879,876	91.76	916,007	90.73
28th February ..	721,640	773,477	870,588	93.25	904,444	94.21	917,249	93.70
31st March	734,874	782,674	883,671	94.32	916,339	95.23	981,042	94.93

STATEMENT OF RATEABLE VALUES.

RATEABLE VALUES.	EDGWARE.		HENDON.		TOTAL.
	£	£	£	£	£
UNREDUCED RATEABLE VALUE (excluding Agricultural Land and Farm Buildings).		200799		1813227/4/-	2014026/4/-
Former Rateable Value of Land and Buildings.		452		1848	2300
Total Unreduced Rateable Value.		£201251		£1815075/4/-	£2016326/4/-
REDUCED RATEABLE VALUE.					
GENERAL HEREDITAMENTS.		197950		1735944	1933894
TITHES. Land covered with water, and land used as Railway other than Freight Transport.		417		3612	4029
INDUSTRIAL HEREDITAMENTS.					
Industrial Purposes	299		14943		
Non-Industrial	56	355	6934	21877	22232
FREIGHT TRANSPORT HEREDITAMENTS.					
Running Lines	274		1504		
Station Buildings, etc.	19		284		
Other Land and Buildings	—	293	—	1788	2081
Reduced Value 31st March, 1939.		£199015		£1763221	£1962236
Reduced Value 1st April, 1938.		£187082		£1729369	£1916451
Increase to Date.		£11933		£33852	£45785

Add In Hands of Cashier
 Balance as above
 1034973 1 8
 6901 2 6
 110376 4 2

STATEMENT OF EXPENDITURE AND

1st April, 1938 to

EXPENDITURE.	Amount Previously Reported.		Amount now Reported.		Total.	
	£	s. d.	£	s. d.	£	s. d.
Parks, Pleasure Grounds and Open Spaces	23550	19 0	4887	9 7	28438	8 7
General Public Health Services	3068	4 7	572	12 2	3640	16 9
Hospital, Maternity and Child Welfare, and Midwifery	13809	4 8	2009	5 10	15818	10 6
County and Trunk Roads	25720	15 10	2497	2 10	28217	18 8
Local Roads	40758	6 10	3642	5 2	44400	12 0
Public Lighting	16412	7 8	7932	19 9	24345	7 5
Traffic Control	2242	12 10	302	9 11	2545	2 9
Street Naming	432	5 6	131	19 9	564	5 3
Public Libraries	7485	10 2	961	0 5	8446	10 7
Town Planning	83	1 5	225	1 2	308	2 7
Public Depôts and Cottages	2479	16 0	259	14 0	2739	10 0
Sewers	15298	11 0	628	10 10	15927	1 10
Refuse Removal and Disposal	27512	6 1	2985	14 1	30498	0 2
Baths and Conveniences	9597	0 5	743	7 5	10340	7 10
Fire Brigade	12103	19 0	1001	8 6	13105	7 6
Salaries and General Establishment Charges	73709	17 8	9643	4 6	83353	2 2
Town Hall and Corporation Estates	4713	0 1	509	18 5	5222	18 6
Dividends and Interest	374	18 5	40	4 6	415	2 11
Mayoral Allowances, etc.	775	2 4	39	8 9	814	11 1
Education Rate Contribution	140950	0 0	12750	0 0	153700	0 0
Precepts of Other Authorities:—						
Middlesex County Council	503502	5 5	—	—	503502	5 5
Metropolitan Police	91829	18 10	—	—	91829	18 10
Assessment Committee	1330	0 0	—	—	1330	0 0
Loan Charges (General)	64052	2 11	46532	3 9	110584	6 8
Stocks and Stores Accounts	4949	17 5	248	11 8	5198	9 1
Purchase of Vehicles	308	5 0	—	—	308	5 0
Contributions to Housing Account	4000	0 0	5224	0 0	9224	0 0
Purchase of Land and Property	—	—	—	—	—	—
Coronation Expenses	—	—	—	—	—	—
Air Raid Precautions	18278	10 0	3085	6 7	21363	16 7
Freedom of the Borough	57	12 7	1	15 0	59	7 7
	£1109386	11 8	106855	14 7	1216242	6 3
Balance—Surplus					22866	6 11
					£1239108	13 2

E AND
 April, 1938 to

INCOME ON RATE FUND ACCOUNTS.

31st March, 1939.

Total.

s. d.
 38 8 7
 46 16 9
 18 10 6
 17 18 8
 90 12 0
 45 7 5
 45 2 9
 54 5 3
 46 10 7
 8 2 7
 9 10 0
 7 1 10
 8 0 2
 0 7 10
 5 7 6
 3 2 2
 2 18 6
 5 2 11
 4 11 1
 0 0 0
 5 5
 19 10
 0 0
 6 8
 9 1
 5 0
 0 0
 16 7
 7 7
 6 3
 6 11
 3 2

INCOME.	Amount Previously Reported.		Amount now Reported.		Total.	
	£	s. d.	£	s. d.	£	s. d.
Parks, Pleasure Grounds and Open Spaces	6579	14 4	179	18 10	6759	13 2
General Public Health Services	1590	1 8	19	15 0	1609	16 8
Hospital and Maternity and Child Welfare	4114	15 9	1188	3 0	5302	18 9
County and Trunk Roads	28998	7 5	7967	17 9	36966	5 2
Local Roads	75	5 6	225	7 4	300	12 10
Public Lighting	1355	15 7	1316	5 2	2672	0 9
Traffic Control	469	9 1	10	0	469	19 1
Public Libraries	1425	6 0	164	12 2	1589	18 2
Town Planning	38	0 6	5	4 6	43	5 0
Public Depôts and Cottages	628	7 1	37	9 10	665	16 11
Sewers and Sewage Disposal	8399	11 7	526	7 3	8925	18 10
Refuse Removal and Disposal	1625	15 6	284	14 3	1910	9 9
Baths and Conveniences	3630	12 9	100	3 5	3730	16 2
Fire Brigade	1696	9 10	163	8 0	1859	17 10
Salaries and Establishment Charges	7371	0 3	4454	5 7	11825	5 10
Town Hall and Corporation Estates	2719	8 8	1014	14 10	3734	3 6
Dividends and Interest	6560	3 11	614	16 0	7174	19 11
Loan Charges (General)	10808	8 9	14588	11 2	25396	19 11
Stocks and Stores Accounts	2329	13 2	218	11 7	2548	4 9
Air Raid Precautions	16222	8 0	3	10 0	16225	18 0
	106638	15 4	33074	5 8	139713	1 0
General Exchequer Grant—Instalment	105511	0 0	15077	0 0	120588	0 0
Rate Income (First Instalment—Nett)	488864	7 2				
		£ s. d.				
Rate Income (Second Instalment)	503068	7 9				
Less 5 per cent. for Allowances, Voids, etc.	25153	8 5				
	477914	19 4			978807	12 2
Supplementals, etc., to 31st March, 1939	11495	18 11	532	6 9		
	£1190425	0 9	48683	12 5	1239108	13 2
					£1239108	13 2

(7)

ACCOUNTS EXAMINED AND APPROVED:

The following orders have been made on the Borough Treasurer for payment of accounts examined and approved in pursuance of Standing Orders and Resolutions of the Council:—

List No.	Date Examined.	Examined by.	General A/c.		Loans Pool.	
			£	s. d.	£	s. d.
—	Previously Reported (Per Minutes, page 547)	164047	2 1	130204	16 6
249—254	27th March, 1939	Councillor F. J. Collins	20514	15 1	—	—
255	27th March, 1939	Councillor F. J. Collins	73794	6 8	—	—
258	27th March, 1939	Councillor F. J. Collins	3989	9 4	—	—
256—257	27th March, 1939	Councillor F. J. Collins	—	—	21833	9 7
259	27th March, 1939	The Mayor (Councillor H. G. Potter)	25000	0 0	—	—
Per Bank Account (Appendix, page 3)			£439383		19	3

260	4th April, 1939	The Mayor (Councillor H. G. Potter)	3520	3 3	—	—
1	4th April, 1939	The Mayor (Councillor H. G. Potter)	6602	6 6	—	—
261—266	13th April, 1939	The Mayor (Councillor H. G. Potter)	3248	10 1	—	—
2—4	17th April, 1939	Councillor G. R. Richardson	23812	18 8	—	—
267—269	24th April, 1939	Alderman J. J. Copestake	2845	13 6	—	—
5—6	24th April, 1939	Alderman J. J. Copestake	25342	15 2	—	—
7	24th April, 1939	Alderman J. J. Copestake	549	2 1	—	—
8	24th April, 1939	Alderman J. J. Copestake	—	—	31 14	5
9	1st May, 1939	Councillor F. J. Collins	3850	3 0	—	—
270—274	1st May, 1939	Councillor F. J. Collins	4648	9 1	—	—

REQUISITIONS SUBMITTED TO COMMITTEES.

	1937-38		Amount Previously Reported	Approved during Recess	SUBMITTED TO COMMITTEE		Total: to 31st Mar., 1939
	£	s. d.			Date	Amount	
SUB-COMMITTEES OF THE EDUCATION COMMITTEE.							
School Management	7352	0 6	7567 17 5	—	28th Mar.	610 19 2	8178 16 7
Works and General Purposes	2998	1 10	2671 11 6	—	" "	397 5 7	3068 17 1
School Medical Services	1907	4 11	647 17 9	—	" "	—	647 17 9
Total Education	12257	7 3	10887 6 8	—		1008 4 9	11895 11 5
COMMITTEES OF THE COUNCIL.							
Public Health and Medical Services:—							
Maternity and Child Welfare	5434	11 0	2780 14 5	—		—	2780 14 5
Public Health	661	6 3	505 18 7	—		—	505 18 7
Isolation Hospital	1285	13 7	1145 1 10	—		—	1145 1 10
Highways	33564	7 0	30735 0 3	—		—	30735 0 3
Estates, Parks and Allotments	2677	19 10	3074 8 5	—		—	3074 8 5
Works and Fire Brigade:—							
Works	16544	12 1	15954 3 7	—		—	15954 3 7
Fire Brigade	1928	6 4	1952 19 10	—		—	1952 19 10
Buildings and Town Planning	5	0 0	2 9 6	—		—	2 9 6
Libraries:—							
General	4957	8 11	4719 10 3	—		—	4719 10 3
Books—Central	640	0 0	697 0 0	—		—	697 0 0
" Golders Green	393	0 0	610 0 0	—		—	610 0 0
" Mill Hill	960	0 0	531 0 0	—		—	531 0 0
" School Libraries	237	6 6	257 11 0	—		—	257 11 0
Finance and General Purposes:—							
Stationery	3229	9 0	3090 2 9	—	20th Mar.	181 18 2	3272 0 11
Clerk's Department	203	12 6	163 14 3	—	" "	7 15 10	171 10 1
Rating and Valuation	140	19 0	41 6 5	—	22nd "	2 0 0	43 6 5
Air Raid Precautions	—	—	1412 18 8	—		—	1412 18 8
Total Council	72923	12 0	67673 19 0	—		191 14 0	67864 13 9
Total Requisitions	82180	19 3	78564 6 5	—		1109 18 0	79673 13 2

EDUCATION SERVICES—School Attendance.

Year ended 31st March	Accommo- dation	NUMBERS ON ROLL		ATTENDANCES	
		At date	Average during year	Average during period	Per- centage
1931 ...	13246	11866	11454	10149	88.7
1932 ...	15118	13570	13144	11783	89.6
1933 ...	15498	14131	13971	12340	88.3
1934 ...	14799	14327	14371	12839	89.5
1935 ...	15543	14308	14262	12782	89.6
1936 ...	15913	14258	14340	12820	89.6
1937 ...	15943	14239	14295	12623	88.3
1938 ...	16069	14248	14291	12632	88.3
Week ended					
20th April, 1938	16069	14247	—	12925	90.7
10th June, ..	16069	14342	—	12799	89.2
9th Sept., ..	16869	14114	—	12672	89.7
4th Nov., ..	16869	14044	—	12557	89.4
21st Dec., ..	16869	14026	—	11688	79.0
20th Jan., 1939	16869	14072	—	12326	87.5
17th Feb., ..	17269	14281	—	12635	88.4
17th March, ..	17269	14322	—	12753	89.0

EDUCATION SERVICES—Employment of Children.

DATE		SCHOOL CHILDREN EMPLOYED			EMPLOYMENT CARDS					
					Issued			Returned		
Day	Year	Boys	Girls	Total	Boys	Girls	Total	Boys	Girls	Total
23rd April	1931	205	17	222	23	2	25	—	—	—
19th April	1932	199	13	203	38	1	39	—	—	—
22nd March	1933	225	14	239	9	—	9	—	—	—
21st March	1934	239	11	247	19	—	19	—	—	—
21st March	1935	360	12	372	23	1	24	3	2	5
20th March	1936	339	17	356	20	—	20	6	—	6
7th April	1937	244	15	259	30	4	34	24	2	26
24th March	1938	353	17	370	38	2	40	8	—	8
Period 1937/38										
4th May	1938	313	15	328	37	1	38	18	—	18
15th June	"	340	16	356	39	1	40	29	2	31
15th September,	"	304	17	321	74	4	78	14	11	25
8th November,	"	278	12	290	46	—	46	26	—	26
5th January,	1939	283	10	293	43	—	43	17	—	17
25th January,	"	299	11	310	21	1	22	14	—	14
22nd February,	"	316	11	327	20	—	20	9	—	9
22nd March,	"	312	10	322	21	—	21	8	1	9

HEALTH SERVICES—School Medical Statistics.

Year ended 31st December	MEDICAL					DENTAL			
	Examinations			Infectious Cases		Attendances at Clinics		Children Examined	Requiring Treatment
	Routine	Special	No of Def- ects found	Notifi- able	Other	Medical	Dental		
1932	5307	8179	3062	165	1680	37232	5806	11795	7020
1933	4921	8909	2871	318	706	36093	6140	9436	4470
1934	3796	7453	2477	496	1172	33001	7507	11898	6739
1935	4709	6846	2531	204	1039	33156	8588	13407	7538
1936	5497	7101	2859	142	1712	38215	13081	9154	6198
1937	4419	7087	1719	155	1054	35576	13782	9509	6055
1938	4457	7717	1679	220	1095	41163	13204	6585	3995
1939									
4 weeks to 28th Jan.	304	490	122	16	40	2477	1190	732	322
4 weeks to 28th Feb.	533	694	211	37	29	3418	1224	603	385
6 weeks to 8th April	731	1113	253	34	56	5088	1517	979	517

HEALTH SERVICES—Maternity & Child Welfare Statistics.

Table I. Attendances for 6 weeks to 8th April, 1939.

Nature of Service	HEALTH CENTRES									
	Central Hendon	West Hendon	Child's Hill	Watling Estate	Mill Hill	Temple Fortune	Edgware	Colindale	Woodside Park	Total
Maternity—General										
Ante-Natal	64	130	80	82	136	—	—	—	—	492
Children under 5 ...	878	708	1071	1349	1156	393	683	495	203	6692
Dental										
Ante-Natal	64	—	33	32	24	—	—	—	—	153
Children under 5 ...	29	—	32	41	22	—	—	—	—	124
Eye										
Children under 5 ...	20	—	—	8	—	—	—	—	—	28
Orthopaedic										
Children under 5 ...	110	—	—	57	—	—	—	—	—	167
Ophthalmia Neonatorum										
Regulations 1926	—	—	—	—	—	—	—	—	—	—
No. of cases to	—	—	—	—	—	—	—	—	—	—
St. Margaret's Hospital	—	—	—	—	—	—	—	—	—	—
Queen Charlotte's "	—	—	—	—	—	—	—	—	—	—
City of London "	—	—	—	—	—	—	—	—	—	2

Table II. General.

Year ended 31st December	MATERNITY CENTRES								Midwives Services		Grants Assisted Milk Supply
	Number of Centres	SESSIONS					Home Visita- tions	Cases attended	Visits		
		Number	Child Atten- dances	Ante Natal Attendances	Total	Average per Session				New Mem- bers	
1932	6	632	34587	597	35184	57	1444	17087	103	2167	156
1933	7	699	38825	687	39512	57	1552	17933	91	2021	858
1934	7	713	39188	1079	40267	57	1618	16008	115	2401	1229
1935	7	712	41249	1242	42491	59	1784	14150	110	2294	1588
1936	8	767	44521	1692	46029	60	1799	15527	118	2440	1715
1937	8	811	49514	2391	51935	64	1823	14571	110	2555	2091
1938	8/9	942	59535	4288	63823	68	2091	15058	134	3320	3032
1939											
4 weeks to 28th Jan.	9	80	4481	376	4857	61	157	1110	28	585	293
4 weeks to 28th Feb.	9	80	5273	402	5675	71	191	892	15	418	292
6 weeks to 8th April	9	116	7211	645	7856	68	238	1670	29	669	417

HENDON BOROUGH (Nursing Associations) SCHEME, 1935.

Number of cases and visits made on behalf of the Hendon Borough Council (children under 5, and expectant and nursing mothers). Scheme operative from 1st October, 1935.

Disease	Visits to Dec. 31st, 1935 (5 mos.)	Visits to Dec. 31st 1936 (12 mos.)	Year to 31st Dec., 1937		Statistics for Period from 1st January to 31st December, 1938											
					Edgware and Little Stanmore		Watling		West Hendon and Colindale		Golders Grn. and East Cricklewood		Mill Hill		Totals	
			Cases	Visits	Cases	Visits	Cases	Visits	Cases	Visits	Cases	Visits	Cases	Visits		Cases
Infantile Diseases—																
Notifiable	—	33	2	38	5	34	—	—	—	—	—	—	—	—	—	5
Other	501	2945	465	2198	44	139	304	1063	126	837	42	203	2	7	518	2200
Maternal Diseases—																
Notifiable	—	—	—	—	—	—	3	30	—	—	—	—	—	—	—	3
Other	96	251	30	196	3	11	—	—	—	—	10	82	11	60	24	
Diseases—																
Notifiable	349	302	—	—	—	—	—	—	—	—	—	—	—	—	—	—
Other	207	1385	167	1123	2	9	16	141	1	9	—	—	3	17	22	
Poor Law Cases ..	258	708	1	10	—	—	—	—	—	—	—	—	—	—	—	—
Totals	1411	5624	665	3565	54	193	323	1234	127	840	52	285	16	84	572	2100

HEALTH SERVICES—General Health Statistics. Table I.
6 weeks to 8th April, 1939.

REMISSION OF FEES		DISEASES NOTIFIED		SANITATION	
Service	Number of Cases	Name	Number of Cases	Details	Number
Doctor under Midwives Acts	10	Scarlet Fever	38	Inspections, visits and Re-inspections made	1740
Council Midwife	3	Diphtheria	25	Complaints received and investigated ...	139
Provision of Dentures	4	Pulmonary Tuberculosis	21	Preliminary and Statutory notices served... ..	126
Dental Treatment	6	Other Forms Tuberculosis	4	Notices Complied with	92
Maintenance in Hospital for confinement	1	Puerperal Fever	—	Special Drain Tests ...	—
Maintenance in Orthopaedic Hospital	3	Puerperal Pyrexia	10		
Provision of Orthopaedic Appliance	2	Erysipelas	5		
Provision of Spectacles... ..	3	Pneumonia	37		
Tonsillectomy	5	Dysentery	2		
Maintenance in Convalescent Home	1	Food Poisoning	—		
Maintenance at Russell Cotes School... ..	6	Ophthalmia Neonatorum	1		
X-Ray Treatment	2	Typhoid Fever... ..	—		
Accouchement Sets	5	Poliomyelitis	—		
Treatment of Squint	1	Malaria	—		
		Cerebro Spinal Fever... ..	1		
		Meningitis	—		
Total	52	Total	144		

General Health Statistics. Table II.

Year ended 31st December	POPULATION				Population 30th June	INFECTIOUS DISEASES				
	Births		Deaths			Notifications	Cases removed to Hospital		Cases under Treatment in Hospital at Date	
	Adjusted Total	Per 1000	Adjusted Total	Per 1000			Number	Per centage		Hendon
1932	1688	13.70	1036	8.40	124477	761	6.15	311	133	47
1933	1673	13.11	1013	7.93	120698	1024	7.89	513	125	97
1934	1643	12.53	1065	8.12	138643	1322	9.53	782	117	108
1935	1724	12.85	1146	8.54	146720	896	6.11	515	96	50
1936	1835	13.04	1166	8.29	155800	777	5.0	301	99	53
1937	1671	10.32	1558	9.61	162079	828	5.11	342	87	64
1938	1914	11.63	1506	9.12	165343	1000	6.05	484	87	55
1939										
4 weeks to 28th Jan.	156	—	182	—	—	75	—	16	1	44
4 weeks to 28th Feb.	164	—	154	—	—	76	—	59	3	76
6 weeks to 8th April	240	—	237	—	—	144	—	67	4	69

FIRE BRIGADE SERVICES.

FIRE BRIGADE.						AMBULANCE.					
	1934-35	1935-36	1936-37	1937-38	1st Apr. to 31st Mar., 1939		1934-35	1935-36	1936-37	1937-38	1st Apr. to 31st Mar., 1939
CALLS—						CALLS—					
Hendon Area ..	163	184	171	216	265	Private Calls ..	655	781	945	1020	1304
Kingsbury Area ..	39	11	—	—	5	Street Calls ..	635	669	683	721	737
Other Areas ..	7	1	—	2	6	Total ..	1290	1450	1628	1741	2041
False Alarms ..	39	61	36	47	57	Mileage run ..	10005	13024	15467	15750	17361
Total ..	248	257	207	265	333	SPECIAL CALLS (Included in Total)					
Mileage run ..	1088	1296	808	1055	1959	For Finchley ..	15	34	27	23	22
TESTS—						For other Authorities	6	13	1	5	—
Alarms ..	5232	4730	4502	5050	5604	Finchley for Hendon	33	—	4	1	4
Hydrants ..	1610	1627	1978	2003	2293	Other Authorities for Hendon ..	6	—	1	5	1
INSPECTIONS—											
Petrol, Factory, etc.	507	826	702	747	554						
Private Appliances	247	233	179	197	49						

REFUSE DESTRUCTOR.

	1934-35		1935-36		1936-37		1937-38		1st April to 31st Mar., 1939	
	T.	C.	T.	C.	T.	C.	T.	C.	T.	C.
OUTGOING MATERIALS—										
Fine Crushed Clinker	—	—	—	—	—	—	—	—	414	4
Coarse ditto	—	—	—	—	—	—	—	—	716	10
Fine Stuff sold	5412	15	4863	5	5541	12	4806	9	2745	17
Fine Stuff used by Departments ..	4256	10	5040	10	3393	—	5428	10	5807	1
Clinker Sold	1152	8	1852	16	526	18	54	9	2270	19
Clinker used by Departments	683	18	218	7	729	16	68	7	912	19
Clinker supplied for Contract Works ..	3074	7	2143	15	161	3	5106	13	2079	10
Tins (Bright) sold	447	7	530	4	525	10	576	14	612	34
Tins (Galvanised) Sold	124	0	142	14	146	7	161	2	136	11
Bottles and Cullett Sold	238	6	401	15	473	10	914	1	499	1
Paper Sold	203	18	—	10	—	—	—	—	29	7
INCOMING REFUSE—										
House Refuse weighed in	28724	19	30842	6	33678	3	34278	11	33428	6
Trade Refuse " "	323	7	374	4	447	16	589	19	668	15
School Refuse " "	—	—	—	—	153	5	139	9	159	5
ELECTRICITY GENERATED—										
Workshop (Central Depot,		B.T. Units		B.T. Units		B.T. Units		B.T. Units		B.T. Units
Refuse Destructor Works		—		—	28658	—	5438	—	4447	—
Clinker Crushing Plant		—		—	—	—	170380	—	193913	—
Totals		—		—	28658		175818		201907	

ADVANCES UNDER THE SMALL DWELLINGS ACQUISITION ACTS
from 3rd July, 1925, to 31st March, 1930.

	Advances completed		Council's Valuation		Amount Applied for		Amount Advanced		Advances now Outstanding		
	Number	Purchase Price	Amount	Per-centage	Amount	Per-centage	Amount	Per-centage	Amount	Per-centage	Number
Now Reported		£	£		£		£		£		
Details	307	279004	255224		205688		199633		47160		147
Percentages of Purchase Price				91%		80%		71%		10%	
Valuation								78%		24%	
Amt. Applied for Advances								97%			
Previous Return		£	£		£		£		£		
Details	307	279004	255224		205688		199633		47660		148
Percentages of Purchase Price				91%		80%		71%		19%	
Valuation								78%		24%	
Amt. Applied for Advances								97%			

HOUSING - Rents Statement.

Week ended	Number of Houses	RENTS DUE				RENTS RECEIVED, etc.				Net Total Current Rents
		Gross Rent Roll	Auctions brought forward	Rents in advance (Deduct)		Total Rents collected	Voids and written off	Auctions carried forward	Rents in advance (Deduct)	
				£	s.					
31st March, 1931	667	839 10 4	309 0 0	2 19 1	1205 17 3	2 17 7	368 4 8	4 18 9	1205 17 3	
26th March, 1932	1012	858 14 8	472 13 10	11 18 7	1319 0 11	2 7 5	458 17 9	10 17 4	1319 9 11	
25th March, 1933	1012	815 2 7	434 17 5	8 0 5	1501 19 7	5 13 11	433 6 0	6 16 11	1201 19 7	
31st March, 1934	1012	818 14 11	433 19 3	10 16 10	1235 17 4	4 2 11	431 10 8	10 2 4	1235 17 4	
30th March, 1935	1148	882 18 11	465 4 1	23 17 0	1327 6 0	27 3 1	424 6 0	41 6 10	1327 6 0	
28th March, 1936	1150	884 6 2	422 3 5	20 7 9	1286 2 10	7 8 5	403 7 7	22 14 3	1286 2 10	
27th March, 1937	1150	881 13 4	462 3 5	18 1 8	1327 15 1	14 6	482 4 0	21 6 8	1327 15 1	
26th March, 1938	1169	902 12 11	439 1 10	21 5 7	1341 4 2	2 19 1	472 7 7	22 10 9	1341 4 2	
1938/39										
7th May, 1938	1177	919 18 1	501 1 1	22 13 9	1398 15 5	16 6	510 7 2	20 6 4	1398 15 5	
25th June, "	1213	955 5 1	562 17 8	35 19 11	1482 2 10	1 15 11	551 15 0	32 8 2	1482 2 10	
17th Sept., "	1205	1007 9 2	543 17 7	40 4 8	1511 17 1	3 6 5	541 4 8	26 12 5	1511 17 1	
29th Oct., "	1270	1012 7 5	546 8 2	24 9 3	1534 11 4	—	558 10 9	25 6 11	1534 11 4	
7th Jan., 1939	1288	1033 9 0	616 11 7	28 9 4	1611 11 3	1 3 6	535 13 8	31 0 3	1611 11 3	
4th Feb., "	1290	1035 15 9	534 3 5	23 9 9	1566 9 5	4 4 8	522 16 10	26 1 11	1566 9 5	
4th March, "	1290	1035 17 9	521 0 4	24 14 1	1532 4 0	4 10 5	502 11 3	24 9 8	1532 4 0	
31st March, "	1290	1036 0 4	503 14 11	23 6 11	1516 8 4	3 11 11	502 16 6	21 18 10	1516 8 4	

HOUSING - General Items.

Week ended	Tenants in Occupation			Tenants in Arrear		Houses under Repair			Cost of Wages and Stores				
	Number	Charges		Amount	Number	Period	Number	£		Number	s.		
		Number Left	New Lettings					d.	d.				
26th March, 1936	1143	1	3	403	266	4 weeks to 25th March, 1936	209	35	7	2	209	35	7
27th March, 1937	1143	1	2	484	301	7 weeks to 30th March, 1937	515	100	5	0	515	100	5
26th March, 1938	1168	1	19	472	298	5 weeks to 29th March, 1938	231	496	4	6	231	496	4
1938/39													
7th May, 1938	1176	1	8	510	304	4 weeks to 26th April, 1938	160	268	3	3	160	268	3
25th June, "	1211	2	36	552	333	6 weeks to 7th June, "	253	637	9	10	253	637	9
17th Sept., "	1261	4	52	521	356	12 weeks to 31st August, "	463	1042	16	0	463	1042	16
29th Oct., "	1279	—	18	528	327	8 weeks to 25th October, "	389	885	14	4	389	885	14
7th Jan., 1939	1287	1	18	528	327	9 weeks to 27th Dec., "	480	1241	1	11	480	1241	1
4th Feb., "	1285	5	2	523	346	4 weeks to 24th Jan., 1939	160	529	3	10	160	529	3
4th March, "	1285	5	—	523	346	4 weeks to 24th Feb., "	215	621	15	2	215	621	15
31st March, "	1286	4	—	504	307	5 weeks to 28th March, "	335	773	2	4	335	773	2

1937-38
1020
721
1741
15750
23
5
1
5
1st April to 31st Mar., 1939
T. C.
414 4
710 10
2743 17
5857 1
2270 19
912 19
2279 10
632 34
136 11
499 1
29 7
3345 6
668 15
159 5
B.T. Units
447
191915
3807
201907
ACTS
19%
24%
148
147
19%
24%

LIBRARY SERVICES.—Statistics for March, 1939.

Table I. Members.

Distribution of Resident Members				Distribution of Non-Resident Members		
Ward	Population, June 1938 (est.)	Total Members	Percentage of Population	Library Authority	Employees, Scholars and those qualified under reciprocal agreements	Subscribers
Central	19416	6533	33.65	Finchley	342	—
Park	16671	5319	31.9	Middlesex	603	—
Golders Green	15695	5301	33.77	Adjoining Library Authorities—		
Mill Hill	24899	8565	34.39	(a) Hampstead	37	1
Childs Hill	18396	3874	21.0	(b) Willesden	36	—
Burnt Oak	21200	5830	27.5	Metropolitan Boroughs	70	—
West Hendon	19232	3073	15.97	(excluding Hampstead)		
Garden Suburb	15347	5973	38.99	Other Authorities	88	3
Edgware	14487	2761	19.05			
Total	165343	47237	28.57	Total	1176	4

Table II. General.

Type	Lectures						Inter Library Loans		Donations	
	Central		Golders Green		Mill Hill		Volumes		Details	Number
	Number	Attendance	Number	Attendance	Number	Attendance	Borrowed	Lent		
Now Reported							55	39		
University Extension	5	59	—	—	—	—			Volumes ...	247
Public Lectures ...	2	128	—	—	—	—			Illustrations	—
Talks to Children ...	2	192	2	135	2	240			Pamphlets ...	4
Story Half-Hours ...	2	25	3	83	2	35			Watercolours	—
									Photographs	—
									Portraits ...	—
									Manuscripts	—
									Sundries ...	—
Total	11	404	5	218	4	275	55	39	Total ...	246
Previously Reported							672	407		
University Extension	18	371	—	—	—	—			Volumes ...	1004
Public Lectures ...	16	1069	—	—	8	308			Pamphlets ...	125
Talks to Children ...	10	1205	10	858	10	1163			Watercolours	—
Story Half-Hours ...	12	392	11	443	12	538			Photographs	6
									Portraits ...	—
									Manuscripts	—
									Sundries ...	6
Total	56	3037	21	1301	30	2009	672	407	Total ...	1141

Comparative Table of Issues.

Period	Central Library		Golders Green Branch		Mill Hill Branch		Deposit Stations	School Libraries	Total (All Services)
	Total Issues.	Daily Average	Total Issues	Daily Average	Total Issues	Daily Average			
March 1932 ...	42944	1959							
March 1933 ...	43948	1920					440	10664	54248
March 1934 ...	42613	1639					380	13012	57340
March 1935 ...	41153	1583					477	18701	61791
March 1936 ...	39030	1501	35669	1372			373	21084	62010
March 1937 ...	40323	1613	35941	1401			287	15717	90703
March 1938 ...	37961	1406	34058	1261	32207	1193	277	15693	91334
Period 1938-39								23095	127321
April 1938 ...	36135	1506	33753	1406	29571	1232	—	6741	106200
May " ...	35887	1380	31771	1222	29103	1119	—	17183	113944
June " ...	34784	1392	29538	1181	26370	1055	—	13939	104337
July " ...	39052	1502	35053	1371	30723	1182	—	11362	110790
August " ...	40002	1576	32348	1244	31251	1202	—	1272	105863
Sept. " ...	35232	1355	31675	1218	26835	1032	—	13458	107200
Oct. " ...	39214	1508	35308	1358	31991	1230	—	15452	121965
Nov. " ...	37920	1458	33707	1293	30642	1178	—	25585	127914
Dec. " ...	32878	1315	30104	1204	26094	1044	—	8000	97076
Jan. 1939 ...	36443	1402	32996	1209	29429	1132	—	7193	106061
Feb. " ...	35406	1475	31416	1309	27777	1157	—	16243	110862
March, " ...	39446	1461	33581	1243	30426	1127	—	30884	134337

Issues—March, 1939.

Classification	Central Library	Golders Green Branch	Mill Hill Branch	Total Central and Branches	School Libraries	Total (All Services)
General Works ...	1240	292	497	2029	435	2464
Philosophy ...	466	329	229	1024	49	1073
Religion ...	442	221	237	900	177	1077
Sociology ...	2040	1214	992	4246	1137	5383
Languages ...	625	153	249	1027	55	1082
Science ...	1084	694	804	2582	1182	3764
Useful Arts ...	2523	801	1637	4961	1703	6664
Fine and Recreative Arts ...	1273	766	856	2895	523	3418
Music ...	755	404	343	1502	—	1502
Literature ...	2518	2135	1364	6067	844	6911
History and Topography ...	3504	2171	2221	7896	1090	8986
Biography ...	1990	1691	1212	4893	306	5199
Local ...	490	—	—	490	—	490
Fiction ...	17501	19834	16333	53668	—	53668
Story Books ...	2478	2826	3452	8756	2383	32139
Books for the Blind ...	27	—	—	27	—	27
Illustrations ...	106	—	—	106	—	106
Holiday Literature ...	384	—	—	384	—	384
TOTAL ...	39446	33581	30426	103453	30884	134337
Daily average issue...	1461	1243	1127	—	—	—
Days open ...	27	27	27	—	—	—

COMPARATIVE STATISTICS.

PUBLIC PARKS.

YEAR ENDED 31st March	TENNIS						BOWLS		PUTTING	MINIATURE GOLF	CONVE-NIENCE FEES (Nos.)
	Counts	Single Tickets	Double Tickets	Court Tickets	Book Tickets	Special Tickets	Rinks	Tickets Sold	Tickets Sold	Tickets Sold	
1932	30	4868	2582	—	—	368	12	206	8260	—	6366
1933	30	3333	1701	3644	81	159	12	194	16840	—	3841
1934	30	1787	471	9445	233	115	12	326	17010	—	5674
1935	32	2633	698	8481	211	177	12	129	16191	5587	7976
1936	32	2511	631	8188	193	119	12	183	13919	4928	7494
1937	32	3154	930	9250	190	208	12	1108	13589	5300	7697
1938	32	4201	1112	11898	225	197	12	500	15058	5659	11200

1st April, 1938, to 31st March, 1939.

Basing Hill ..	2	357	44	958	—	—	—	—	2581	—	2805
Childs Hill ..	2	230	38	628	33	—	6	46	—	—	—
Chitterhouse ..	4	145	34	864	15	—	—	—	—	—	1174
Hendon ..	9	1414	340	4130	88	72	—	—	7546	—	539
Mill Hill ..	3	511	144	1545	26	61	6	297	—	6545	1486
Princes ..	2	471	147	980	33	—	—	—	—	—	933
Stone Grove ..	2	508	150	1310	10	—	—	—	1691	—	1951
Sunny Hill ..	4	273	58	1183	15	22	—	—	1610	—	1027
Watling ..	2	106	58	786	7	—	—	—	2764	—	—
West Hendon ..	2	109	21	381	9	—	—	—	—	—	1052
Montrose ..	2	62	10	180	6	—	—	—	—	—	738
Totals ..	34	4186	1050	13245	242	155	12	343	16192	6545	11705
Increase on last return	—	148	36	371	7	4	—	—	—	—	616

PUBLIC LAVATORIES.

YEAR ENDED 31st March	LADIES						GENTLEMEN			
	Convenience			Nos.	Towels		Convenience		Towels	
	W.C's	Free	Total		Basins	Nos.	W.C's	Nos.	Basins	Nos.
1932	12	3	15	35475	4	239	11	34401	4	937
1933	12	3	15	29812	4	171	11	33793	4	603
1934	10	4	23	37616	6	177	16	40270	6	726
1935	28	4	32	42268	10	304	21	53589	10	1192
1936	28	4	32	51133	10	551	21	66272	10	1870
1937	28	4	32	56804	10	1839	21	77244	10	2397
1938	28	4	32	61154	10	1910	21	78912	10	2702

1st April, 1938, to 31st March, 1939.

"The Bell" ..	5	1	6	10273	2	369	4	13669	2	420
Childs Hill ..	4	1	5	10501	2	263	4	11771	2	479
Cricklewood Lane ..	2	—	2	7327	—	—	2	19360	—	—
Edgware ..	5	—	5	6947	2	391	2	6871	2	532
Mill Hill ..	4	—	4	12862	2	437	3	8578	2	582
Orange Hill Road ..	5	1	6	6113	2	289	3	8793	2	565
West Hendon ..	3	1	4	6443	—	120	3	10282	—	—
Hendon Central ..	5	1	6	2240	2	102	4	2638	2	166
Totals ..	33	5	38	62706	12	1971	25	81047	12	2744
Increase on last return	5	1	6	5540	2	181	4	6987	2	240

PUBLIC SLIPPER BATHS.

YEAR ENDED 31st March	1st CLASS		2nd CLASS		Extra Towels	Soap	Unemp'oyed (Free Baths)
	No. of Baths	Tickets Sold	No. of Baths	Tickets Sold			
1932	8	4842	25	17678	1043	8420	—
1933	8	3967	25	17980	962	6025	331
1934	8	3722	25	19113	844	7212	141
1935	8	3866	25	19251	875	7499	46
1936	8	3671	25	18230	821	7340	10
1937	8	3881	25	19385	1141	8074	61
1938	8	3836	25	21040	1206	8281	100

1st April, 1938, to 31st March, 1939.

Child's Hill ..	2	111	5	2877	10	120	—
Ladies ..	2	719	6	4191	208	1490	—
Gentlemen ..	2	—	—	—	—	—	—
Total ..	4	830	11	7068	308	1610	—
West Hendon ..	2	151	6	3921	200	1828	—
Ladies ..	2	1746	8	9511	687	4078	69
Gentlemen ..	2	—	—	—	—	—	—
Total ..	4	900	14	13432	877	5906	69
Increase on last return	—	202	—	20500	1185	7516	69

OPEN AIR SWIMMING POOL—MILL HILL.

(16)

Details.	1936		1937		1938	
	2nd May—27th Sept.	Tickets Sold	1st May—3rd October	Tickets Sold	30th April—27th Sept.	Tickets Sold
SESSIONS:—						
Adults.—						
Sundays & Bank Holidays	9387		10476		6556	
Weekdays	23657	33044	30242	40718	21308	27924
Children.—						
Sundays & Bank Holidays	4610		4987		3441	
Weekdays	17061	21671	23589	28576	18955	22396
Season Pass.—						
Sundays & Bank Holidays	1918		1874		1594	
Weekdays	6370	8288	6814	8688	6604	8195
SUB-TOTAL		63003		77982		58518
School Children.—						
Hendon	6723		9661		6390	
Other Authorities	—	6723	—	9661	878	7268
TOTAL BATHERS		69726		87043		65786
MISCELLANEOUS:—						
Parking.—						
Cars	2519		3438		2347	
Motor Cycles	490		563		381	
Bicycles	6802		9487		7260	
Season Tickets	2	9813	1	13189	2	9990
Deposits.—						
Costumes		2757		4010		1835
Season Tickets.—						
Resident	244		202		92	
Adults					160	
School Children					2	
Non-Resident	8	252	5	207		254
Hire of Towels, Cap, Costume and Slips		7725		9856		5829
Weighing Machines		3034		3557		2587

OPEN AIR SWIMMING POOL—WEST HENDON.

Details.	1935		1936		* 1937		1938	
	4th May—29th Sept.	Tickets Sold	2nd May—27th Sept.	Tickets Sold	3rd July—3rd October	Tickets Sold	26th April—2nd Oct.	Tickets Sold
SESSIONS:—								
Adults.—								
Sundays & Bank Holidays	3001		1769		2568		—	
7 a.m. to 12.30 p.m.	—		—		—		2171	
1.30 p.m. to closing	—		—		—		1852	
Weekdays	8578	11579	4341	6110	9549	12117	11926	15929
Children.—								
Sundays & Bank Holidays	1443		866		1124		—	
7 a.m. to 12.30 p.m.	—		—		—		574	
1.30 p.m. to closing	—		—		—		1039	
Weekdays	9490	10933	6137	7003	6363	7487	8547	10260
Season Pass.—								
Sundays & Bank Holidays	—		—		506		836	
Weekdays	—		—		1932	2438	2853	3689
SUB-TOTAL		22512		13113		22042		29878
School Children.—								
Hendon	1206		3445		981		6825	
Other Authorities	—	1206	—	3445	—	981	—	6825
TOTAL BATHERS		23718		16558		23023		36703
MISCELLANEOUS:—								
Parking.—								
Cars					176		304	
Motor Cycles					82		119	
Bicycles					937		2237	
Season Tickets					—		—	2660
Deposits.—								1036
Costumes								
Season Tickets.—								
Resident					43		—	
Adults					—		35	
School Children					—		23	
Non-Resident					9		5	63
Hire of Towels, Cap, Costume and Slips								3652
Weighing Machines								900

* Reconstructed.

WAGES RETURN.

Year Ended 31st Mar.	Net Wages Paid.	Deductions					Contributions		TOTAL
		Compulsory		Voluntary			Super-annuation	N.H. & U. Insurances	
		Super-annuation	N.H. & U. Insurances	Sports Subscriptions	Club Socials	Industrial Orthopaedic Society			
1931 (53 weeks)	84735 15 3	1438 0 11	1501 17 10	—	—	—	1438 0 11	1672 3 5	90785 18 4
1932	81898 7 0	1416 7 3	1557 11 9	—	—	—	1416 7 3	1688 5 1	87976 18 4
1933	82166 4 3	1368 7 2	1711 2 11	—	—	—	1368 7 2	1805 7 10	88419 9 4
1934	95367 11 9	2049 0 2	1971 13 10	—	—	—	2049 0 2	2077 11 2	103514 17 1
1935	102007 4 7	2107 11 7	2101 18 11	—	—	50 8 0	2107 11 7	2215 12 6	110591 7 2
1936 (53 weeks)	107592 19 3	2581 11 11	2227 13 2	—	—	58 19 11	2581 11 11	2360 4 4	117403 0 6
1937	106580 12 3	2465 6 2	2072 2 11	—	—	56 17 4	2465 6 2	2210 3 5	115850 8 3
1938	116027 19 0	2405 4 10	2204 5 1	—	—	57 0 2	2405 4 10	2383 10 5	125483 4 4
1938 Week Ended									
April 7	2127 15 8	45 16 4	38 13 2	—	—	1 1 10	45 16 4	42 11 11	2301 15 3
14	2188 7 0	46 4 11	38 18 4	—	—	1 1 8	46 4 11	41 14 10	2362 11 8
21	2283 18 4	46 8 8	39 3 0	—	—	1 1 10	46 8 8	42 19 6	2440 0 0
28	2261 4 0	46 16 10	40 4 0	—	—	1 1 11	46 16 10	43 4 3	2439 7 10
May 5	2257 15 4	46 11 10	40 14 6	—	—	1 1 6	46 11 10	45 3 10	2437 18 10
12	2287 13 6	46 14 10	40 16 1	—	—	1 1 9	46 14 10	44 0 3	2467 1 3
19	2315 7 3	46 13 4	41 9 2	—	—	1 1 9	46 13 4	45 8 10	2496 13 8
26	2336 0 9	46 6 6	42 6 0	—	—	1 1 8	46 6 6	45 15 0	2517 16 5
June 2	2372 13 3	46 10 0	42 7 4	—	—	1 1 7	46 10 0	46 4 2	2555 6 4
9	2406 0 4	46 11 2	43 16 3	—	—	1 1 8	46 11 2	47 9 3	2501 9 10
16	2445 17 8	46 10 7	43 2 8	8 4 6	—	1 1 8	46 10 7	47 2 8	2641 10 4
23	2471 6 9	46 11 11	45 7 2	2 18 4	11 1 8	1 1 9	46 11 11	48 8 5	2673 7 11
30	2512 19 7	46 12 1	44 19 5	2 17 0	11 7 6	1 1 8	46 12 1	49 7 9	2715 17 1
July 5	2476 14 3	46 9 5	44 11 6	2 17 10	11 10 8	1 1 8	46 9 5	48 5 2	2677 19 11
12	2472 13 1	46 1 1	44 12 7	2 16 8	11 17 4	1 1 8	46 1 1	48 7 10	2673 11 4
19	2504 10 0	46 10 6	44 17 0	2 17 0	11 11 0	1 1 10	46 10 6	48 13 11	2707 9 9
26	2517 3 10	46 18 9	45 7 4	2 18 6	11 11 0	1 1 9	46 18 9	48 17 4	2720 17 3
Aug. 2	2525 7 5	46 9 8	44 17 7	2 17 0	11 15 0	1 1 6	46 9 8	48 14 6	2727 12 4
9	2554 4 7	46 10 5	44 0 3	2 18 4	12 8 2	1 2 2	46 10 5	47 19 9	2759 3 1
16	2534 5 4	46 8 10	45 18 11	2 18 2	12 1 10	1 1 7	46 8 10	50 0 11	2739 4 5
23	2541 1 2	46 12 8	44 17 11	2 17 10	12 16 8	1 1 9	46 12 8	48 10 5	2744 11 1
30	2481 10 9	46 11 7	44 5 1	2 17 10	12 15 2	1 1 10	46 11 7	48 3 11	2683 17 9
Sept. 6	2467 19 11	47 8 10	45 19 4	2 18 2	12 16 4	1 1 9	47 8 10	49 13 5	2675 6 7
13	2465 9 3	48 16 4	44 14 8	2 19 10	13 0 2	1 1 10	48 16 4	48 7 11	2673 6 4
20	2471 19 6	48 4 3	44 15 4	2 18 2	13 3 10	1 1 9	48 4 3	48 8 3	2678 15 4
27	2503 9 3	48 4 3	43 13 11	2 17 8	13 0 4	1 1 9	48 4 3	47 4 0	2777 15 5
Oct. 4	2574 12 5	47 12 1	42 1 2	2 17 0	12 12 0	1 1 6	47 12 1	46 2 5	2774 10 8
11	2507 2 9	47 18 3	43 2 11	2 18 6	13 2 0	1 1 9	47 18 3	47 5 7	2600 10 0
18	2378 8 5	48 9 6	42 14 10	3 12 2	13 3 10	1 1 10	48 9 6	46 17 9	2582 17 10
25	2388 5 9	47 19 2	43 3 2	3 2 2	14 1 4	1 1 6	47 19 2	47 6 0	2592 18 9
Nov. 1	2403 7 3	48 5 8	43 12 11	3 3 8	13 17 10	1 1 8	48 5 8	47 14 3	2600 8 11
8	2376 18 3	48 0 6	43 9 3	3 3 6	14 3 6	1 1 7	48 0 6	47 10 3	2582 7 4
15	2394 11 7	47 15 8	44 0 0	3 3 8	14 3 4	1 1 6	47 15 8	47 19 9	2600 11 2
22	2415 13 8	48 0 6	44 16 11	3 4 6	14 5 0	1 1 9	48 0 6	48 17 11	2624 0 9
29	2415 13 0	48 1 4	44 2 8	3 3 10	14 6 8	1 1 7	48 1 4	47 17 4	2622 7 0
Dec. 6	2418 0 4	48 18 11	44 14 11	3 0 0	14 9 6	1 1 9	48 18 11	48 7 8	2627 12 0
13	2402 9 4	48 2 5	44 5 8	3 5 2	14 8 4	1 1 8	48 2 5	48 8 4	2619 3 4
20	2378 19 7	47 14 10	44 0 11	3 7 4	14 8 2	1 1 6	47 14 10	47 4 1	2584 11 3
27	2956 13 9	47 8 1	42 1 10	3 6 10	14 7 2	1 1 7	47 8 1	46 1 4	3158 8 8
1939									
Jan. 3	2804 3 7	46 18 3	55 8 11	3 5 0	13 6 6	1 1 2	46 18 3	58 8 11	3020 10 7
10	2401 11 6	47 0 8	45 4 6	2 18 2	14 19 4	1 1 10	47 0 8	47 3 2	2604 10 10
17	2393 2 8	47 15 8	43 10 6	3 6 2	15 8 4	1 1 8	47 15 8	47 8 8	2599 9 4
24	2364 15 2	47 4 11	43 15 0	3 4 6	15 16 6	1 1 5	47 4 11	47 5 9	2570 8 2
31	2778 15 7	47 11 1	46 18 8	3 3 10	15 7 8	1 1 10	47 11 1	50 5 1	2908 14 10
Feb. 7	2349 12 3	47 2 2	43 9 9	3 3 0	15 0 6	1 1 3	47 2 2	47 2 10	2553 13 11
14	2364 14 3	47 1 6	43 12 10	3 4 10	15 3 2	1 2 2	47 1 6	46 10 3	2568 10 6
21	2337 7 7	47 2 1	42 13 6	3 3 8	15 10 10	1 2 1	47 2 1	46 8 3	2540 10 1
28	2322 19 2	47 5 9	41 18 0	3 4 6	15 8 0	1 2 1	47 5 9	44 13 3	2523 16 6
Mar. 7	2274 16 4	47 8 5	41 14 1	3 3 4	15 9 2	1 2 1	47 8 5	45 1 7	2476 3 5
14	2282 2 4	47 9 4	41 9 8	3 3 4	15 6 2	1 2 2	47 9 4	45 7 2	2481 0 8
21	2288 9 0	47 10 4	41 0 10	3 3 2	15 1 10	1 2 1	47 10 4	44 13 1	2488 10 8
28	2109 2 2	47 18 7	42 2 3	3 3 4	14 19 2	1 2 1	47 18 7	45 14 3	2512 0 5
A.R.P.	2611 5 9	—	73 16 0	—	—	—	—	74 11 10	2759 13 7
Totals	£128500 1 2	2456 0 3	2335 19 2	134 8 0	561 2 6	56 10 2	2456 0 3	2529 14 3	13079 15 9

Year to 31
Year to 31
Year to 31
Year to 31
Year to 31
Year to 31
Year to 31

Sewerage
Road Impr
Main
Local
Private
Public Lic
Parks and
Public Off
Public Dep
Fire Stat
Health Se
Hospit
Mater
Public
Mortu
Bath
Public Li
Allotment
Small Dw
Housing
Housing
Education
Elem
High
Loans P
Prior

LOAN DEBT STATEMENT

Particulars.	Balance Outstanding 1st April.	New Loans	Repayments	Balance Outstanding 31st March.
† Year to 31st March, 1931	£1,298,535 14 7	£742,456 3 2	£56,483 19 4	£1,984,507 18 5
Year to 31st March, 1932	£2,012,708 3 8	£205,025 10 9	£85,745 3 8	£2,131,988 10 9
Year to 31st March, 1933	£2,131,988 10 9	£150,932 19 6	£135,395 12 10	£2,147,525 17 5
Year to 31st March, 1934	£2,147,525 17 5	£305,020 17 2	£615,939 18 2	£2,336,606 16 5
Year to 31st March, 1935	£2,336,606 16 5	£70,120 0 0	£67,764 2 9	£2,338,962 13 8
Year to 31st March, 1936	£2,338,962 13 8	£75,500 0 0	£182,049 18 2	£2,232,412 15 6
Year to 31st March, 1937	£2,232,412 15 6	£241,250 0 0	£66,785 18 9	£2,406,876 16 9
Year to 31st March, 1938	£2,406,876 16 9	£247,052 12 8	£310,238 4 0	£2,343,691 5 5
Purpose.	Balance Outstanding 1st April, 1938	New Loans and Advances to Borrowing Accounts to 31st Mar., 1939	Repayments and Advances from Loans Pool to 31st Mar., 1939	Balance Outstanding at 31st Mar., 1939
Sewerage and Sewage Disposal	32194 10 4	22410 0 11	63947 19 1	280405 12 2
Road Improvements:—				
Main and County Roads	67591 15 0	24205 0 0	7149 13 0	84647 2 0
Local Roads	82602 8 1	12582 0 0	10974 0 11	81210 7 2
Private Streets	49470 13 6	16800 0 0	13137 8 8	53133 4 10
Public Lighting	—	2500 0 0	—	2500 0 0
Parks and Pleasure Grounds	428530 8 11	42340 0 0	20982 7 5	446888 1 6
Public Offices and Buildings	64327 1 8	2650 0 0	5609 7 2	63367 14 6
Public Depots	9432 10 0	8000 0 0	815 0 0	16617 10 0
Fire Station, etc.	25339 2 8	6500 0 0	8879 5 0	22939 17 8
Health Services:—				
House Refuse Collection	26217 8 5	—	2464 5 9	23753 2 8
Hospitals	60261 8 6	—	3002 17 0	57258 11 6
Maternity and Child Welfare	17888 6 3	—	869 7 2	17018 19 1
Public Conveniences	5914 5 3	2900 0 0	456 18 2	8357 7 1
Mortuary	183 3 5	—	38 2 8	145 0 9
Baths and Washhouses	42628 13 4	450 0 0	2161 6 0	40917 7 4
Public Libraries	42247 8 7	—	2017 2 2	40230 6 5
	1244576 3 11	141337 0 11	140505 0 2	1245408 4 8
	13790 2 4	—	287 17 6	13502 4 10
Allotments	50899 0 9	5000 0 0	8747 7 9	47151 13 0
Small Dwellings Acts, Advances	157 13 0	—	17 10 4	140 2 8
Housing (1923 Act), Subsidies	658561 17 3	52152 0 0	34923 16 11	675790 0 4
Housing	—	—	—	—
Education:—				
Elementary	317325 0 2	85946 0 0	59731 8 4	343539 11 10
Higher	7844 15 4	—	155 14 4	7689 1 0
	2293154 12 9	284435 0 11	244308 15 4	2333220 18 4
	50536 12 8	222522 0 11	202693 11 7*	70395 2 0
Loans Pool				
	£2,343,691 5 5	£506,957 1 10	£447,062 6 11	£2,403,586 0 4

* Advances from Pool 325447 5 2
 Repayments to Pool 122753 13 7

† Prior to transfer of Parish of Edgware.

£202693 11 7

(19)

LOAN SANCTIONS RECEIVED—From 1st April, 1938, to 31st March, 1939:

No.	Date of Sanction.	Purpose.	Amount.	Period, Years.
			£	
482	12th April, 1938	Relief Sewer—Hale Lane and Station Road, Edgware.....	7600	30
483	3rd May, 1938	Mote Park Estate	4425	60
484	11th May, 1938	Hendon Central (Queen's Road) Convenience	2900	20
485	12th May, 1938	Small Dwellings Acquisition Act—Advances	10000	20
486	17th May, 1938	Private Street Improvements—Group 66	2968	7
487	23rd May, 1938	Dole Street School—Erection	24995	40
488	23rd May, 1938	Dole Street School—Heating	1118	15
489	2nd June, 1938	Private Street Improvements	3595	7
490	16th June, 1938	Copthall Playing Fields—Lay-out	5600	10
491	29th June, 1938	Frith Manor Council School	1520	15
492	15th July, 1938	Colindale School—Site	317/11/10	—
493	18th Aug., 1938	Colindale School—Alterations	6050	15
494	25th Aug., 1938	Private Street Improvements	1049	7
495	25th Aug., 1938	Private Street Improvements	228	7
496	25th Aug., 1938	Private Street Improvements	73	7
497	26th Aug., 1938	Golf Course Estate	15900	60
498	8th Sept., 1938	Frith Manor School—Furnishing	710	10
499	9th Sept., 1938	Edgware Main Drainage	9900	30
500	21st Oct., 1938	Colindale School—Heating	303	15
501	10th Jan., 1939	Private Street Improvements	7000	7
502	12th Jan., 1939	Dole Street School—Furnishing	650	10
503	25th Jan., 1939	Finchley Road Improvement	12640	15
504	26th Jan., 1939	Woodcroft Park Shelter	530	30
505	6th Feb., 1939	Derby House	2650	20

PAYMENTS TO CONTRACTORS UNDER ENGINEER'S CERTIFICATES:

From 1st April, 1938, to 31st March, 1939.

Amounts Certified by Engineer.

Contract Works No.	Amount of Contract.	Previously Reported.	Now Reported.		Total Certified.	Amount of Retention.
			Certificate Numbers.	Amount.		
	£ s. d.	£ s. d.		£ s. d.	£ s. d.	£ s. d.
301	31446 15 2	20360 0 0	—	—	20360 0 0	5434 0 0
301	Kerb	1523 16 2	—	—	1523 16 2	—
301	Surfacing	3692 4 5	—	—	3692 4 5	—
320	11329 19 10	11586 13 3	—	—	11586 13 3	—
320a	1869 0 0	1704 6 3	—	—	1704 6 3	—
320b	488 10 0	475 6 6	—	—	475 6 6	—
340	9755 0 0	9000 0 0	—	—	9000 0 0	166 7 5
340	980 10 0	940 16 0	—	—	940 16 0	—
344	4188 0 0	4069 6 0	—	—	4069 6 0	—
344	239 14 3	251 14 3	—	—	251 14 3	—
352	13987 3 6	13987 3 6	—	—	13987 3 6	—
355	18288 0 0	15325 0 0	—	—	15325 0 0	1828 0 0
355	1230 0 0	1255 19 0	—	—	1255 19 0	—
360	8027 19 1	6010 10 1	—	—	6010 10 1	—
360	S.W.D.	—	1	301 3 0	301 3 0	—
363	4282 0 8	2556 6 2	—	—	2556 6 2	—
364	683 15 2	585 17 3	—	—	585 17 3	—
365	7573 5 0	6549 0 0	—	—	6549 0 0	727 9 2
366	72146 0 0	68374 0 0	14	3405 13 11	71779 13 11	—
366	10646 6 8	7038 0 0	9	782 2 1	7820 2 1	—
366	Kerb	841 1 11	—	—	841 1 11	—
366	Surfacing	246 2 1	—	—	246 2 1	—
366	Surfacing	1326 8 7	—	—	1326 8 7	—
367	3950 0 0	3749 5 0	—	—	3749 5 0	—
368	1600 0 0	1182 0 0	—	—	1182 0 0	62 7 6
369	2675 0 0	2033 0 0	—	—	2033 0 0	267 0 0
371	20473 0 0	15779 0 0	—	—	15779 0 0	2047 0 0

PAYMENTS TO CONTRACTORS UNDER ENGINEER'S CERTIFICATES—Contd.:

Contract Works No.	Amount or Contract.	Amounts Certified by Engineer.					Amount of Retention.
		Previously Reported.	Now Reported		Total Certified.		
			Certificate Numbers.	Amount.			
£ s. d.	£ s. d.	£ s. d.	£ s. d.	£ s. d.	£ s. d.		
385	Surfacing	689 2 6	—	—	689 2 6	—	
385	Surfacing	99 19 9	—	—	99 19 9	—	
385	595 6 1	311 2 6	—	—	311 2 6	—	
385	Surfacing	115 17 6	—	—	115 17 6	—	
385	Surfacing	18 10 6	—	—	18 10 6	—	
385	Kerb	418 5 8	—	—	418 5 8	—	
386	5163 0 0	3298 0 0	5	697 0 0	3995 0 0	999 0 0	
386	853 0 0	713 6 0	—	—	713 6 0	79 5 0	
387	7761 2 0	6178 8 6	—	—	6178 8 6	—	
387	Kerb	526 19 0	—	—	526 19 0	—	
387	Surfacing	1134 8 5	—	—	1134 8 5	—	
387	Surfacing	135 16 11	—	—	135 16 11	—	
389	1443 7 8	669 0 0	2	66 19 3	735 19 3	—	
389	1375 6 7	831 0 0	—	—	831 0 0	92 2 3	
389	Kerb	452 7 1	—	—	452 7 1	—	
389	Surfacing	403 13 9	—	—	403 13 9	—	
389	Surfacing	57 9 6	—	—	57 9 6	—	
391	1798 8 5	838 9 10	—	—	838 9 10	—	
391	Kerb	601 15 5	—	—	601 15 5	—	
391	1652 2 0	754 16 2	—	—	754 16 2	—	
391	Surfacing	503 12 6	—	—	503 12 6	—	
391	Surfacing	63 19 4	—	—	63 19 4	—	
391	Surfacing	320 16 3	—	—	320 16 3	—	
391	Surfacing	83 15 2	—	—	83 15 2	—	
392	2742 7 11	1659 0 0	4	184 2 7	1843 2 7	—	
392	Kerb	325 0 9	—	—	325 0 9	—	
394	552 12 10	377 0 0	—	—	377 0 0	39 4 7	
394	Kerb	107 15 4	—	—	107 15 4	—	
397	23577 18 3	13697 0 0	7	3061 0 0	16758 0 0	2358 0 0	
398	790 0 0	711 0 0	—	—	711 0 0	79 0 0	
399	34179 4 6	2000 0 0	2	3120 0 0	5120 0 0	1280 0 0	
401	1369 9 9	339 0 0	—	—	339 0 0	84 16 11	
401	1415 17 10	373 0 0	—	—	373 0 0	93 13 4	
401	3006 7 3	674 0 0	—	—	674 0 0	168 2 6	
401	867 0 2	216 0 0	—	—	216 0 0	54 17 2	
401	Kerb	—	1	1008 0 0	1008 0 0	112 0 0	
405	414 0 0	216 0 0	2	112 6 10	328 6 10	36 0 0	
Surfacing	326 0 6	334 19 3	—	—	334 19 3	—	
Tennis Courts	345 6 0	334 13 6	—	—	334 13 6	—	
Fire Alarm Equipment	259 16 7	266 16 7	—	—	266 16 7	—	
Brent Street	950 0 0	950 0 0	—	—	950 0 0	—	
Traffic Signals	234 0 0	234 0 0	—	—	234 0 0	—	
Refuse	1200 0 0	830 0 0	—	—	830 0 0	93 1 0	
Equipment	514 10 0	514 10 0	—	—	514 10 0	—	
Schools:—	2335 0 0	2335 0 0	—	—	2335 0 0	—	
Bell Lane	172 10 0	162 11 0	—	—	162 11 0	—	
Redecorations, 1938	1059 0 0	1009 8 3	—	—	1009 8 3	—	
	215 0 0	206 15 6	—	—	206 15 6	—	
	694 0 0	674 10 4	—	—	674 10 4	—	
	162 0 0	101 16 0	—	—	101 16 0	—	
A.R.P.:—							
Trenches	—	2061 11 11	—	872 19 9	2934 11 8	—	
Shelters	—	228 18 7	—	411 7 3	640 5 10	—	
Timber	—	5122 18 7	—	270 2 11	5393 1 6	—	
Totals, 1938/39					£336447 12 5	£17311 5 7	

QUOTATIONS ACCEPTED, CONTRACTS LET, ETC.:

(22)

Date of Minute.	Minute Folio.	Particulars.	Amount of Contract.
1938.		Education:—	
20th June	708	Edgware (Junior and Infants') School Sub-Contract —Playground surface—Constable Hart & Co., Ltd.	£ s. d. 5/6d. per square yard.
20th June	709	Woodside Park (Junior and Infants') School Sub-Contracts (Frith Manor School):— Steelwork—Cook & Co., Ltd. — — — Tile Floors—Kleine & Co., Ltd. — — — Heating Installation—Hope's Heating & Lighting, Ltd.	514 3 9 48 13 11
18th July	854	Screens—Kingfisher, Ltd. Casings—Kingfisher, Ltd. Sanitary Fittings—G. Wright (London), Ltd. Cloakroom Fittings—Parker, Winder & Achurch Flooring (Beech)—Hollis Bros. & Co., Ltd. — Flooring—Granwood Flooring Co., Ltd. Playground—Constable Hart & Co., Ltd. Furniture—Kingfisher, Ltd. Ironmongery—Parker, Winder & Achurch Ironwork—Garton & Thorne, Ltd. Wall Tiling—Camden Tile & Mosaic Co., Ltd.	1448 0 0 727 3 6 56 11 9 528 4 4 300 2 6 367 15 6 425 6 2 785 14 11 428 14 4 98 6 8 19 6 0 15/- and 15/4 per yard
5th Dec.	70	Shelving—North of England School Furnishing Co., Ltd.	30 8 8
1939.		Electric Fittings—Lustray Products	96 1 6
30th Jan.	226	Oak Fencing—Quenby, Fry & Co., Ltd.	159 4 9
30th Jan.	226	Fire Appliances—Nuswift Engineering Co., Ltd.	33 4 6
1938.			
18th July	856	Colindale School Extension—Garsubil, Ltd. — —	5163 0 0
10th Oct.	978	Colindale School Sub-Contracts:— Electrical—C. E. Keates Flooring—Granwood Flooring Co., Ltd. Flooring—Hollis Bros., & Co., Ltd. Wall Casings—Mattozene Steelwork—T. C. Jones & Co., Ltd. Cloakroom Fittings—S. Parkes & Co., Ltd. Screens—North of England Furnishing Co., Ltd. Sanitary Fittings—J. Bolding & Sons, Ltd. Roof Tiling—Williams, Smith & Evans Casements and Glazing—Mellowes & Co., Ltd. Heating—Z. D. Berry & Sons, Ltd. Wall Tiling—Camden Tile & Mosaic Co., Ltd.	115 0 0 162 9 6 86 1 5 30 4 0 118 2 6 124 7 3 163 17 6 175 12 9 95 13 3 447 18 8 853 0 0 15/9 and 16/9 per yard 30 8 6
5th Dec.	71	Electric Fittings—Lustray Products	35 11 9
1939.			
30th Jan.	227	Ironmongery—Parker, Winder & Achurch, Ltd.	
1938.			
20th June	710	Annual Schedule for School Repairs:— Barnfield School and Cottage—J. M. Jones Burnt Oak School and Cottage—W. Richards and Sons (Hendon), Ltd. Childs Hill School and Cottage—W. Richards and Sons (Hendon), Ltd. Sunnyfields School—W. Richards & Sons (Hendon), Ltd. Childs Hill Infants' School—W. Richards and Sons (Hendon), Ltd. Garden Suburb School and Cottage—Buckingham & Sons, Ltd. The Hyde School and Cottage—Buckingham and Sons, Ltd.	215 0 0 105 0 0 145 0 0 125 0 0 125 0 0 185 0 0 173 0 0

QUOTATIONS ACCEPTED, CONTRACTS LET, ETC.—Contd.:

Date of Minute.	Minute Folio.	Particulars.	Amount of Contract.
1938.		Education—Contd.:—	£ s. d.
		Wessex Gardens School and Flat—Buckingham and Sons, Ltd.	175 0 0
		Clitterhouse School and Bungalow—Buckingham & Sons, Ltd.	177 0 0
		Deansbrook Junior School and Bungalow—Buckingham & Sons, Ltd.	173 0 0
		St. Vincent's R.C. School—Buckingham & Sons, Ltd.	75 0 0
		St. Mary's C. of E. School—Buckingham and Sons, Ltd.	41 0 0
		Bell Lane—Water Supply—Buckingham & Sons, Ltd.	60 0 0
		Goldbeaters Senior and Junior Schools—A. J. Willson & Sons	75 0 0
		The Meads—Shed—A. J. Willson & Sons	27 0 0
18th July	854	Fire Appliances—Edgware School—S. Dixon and Son, Ltd.	24 4 6
18th July	856	Dole Street Junior and Infants School—Taylor Woodrow Construction, Ltd.	23577 18 3
10th Oct.	1011	Dole Street School—Sub-Contracts:—	
		Roof Tiling—H. J. Greenham, Ltd.	624 8 6
		Steelwork—Cook & Co.	451 3 3
		Casements—R. E. Pearse & Co.	1254 2 6
		Heating—Z. D. Berry & Sons, Ltd.	777 10 0
10th Oct.	1021	Screens—Kingfisher, Ltd.	353 10 0
		Lantern Lights—Heywood & Co., Ltd.	145 0 0
		Sanitary Fittings—Wilson & Wylie	390 14 8
		Electrical—Keates, C. E., Ltd.	462 0 0
		Furniture—Kingfisher, Ltd.	498 6 4
5th Dec. 1939.	80		
30th Jan.	219	Strip Flooring—Hollis Bros. & Co., Ltd.—per square	4 6 6
30th Jan.	219	Woodblock Flooring—Hollis Bros. & Co., Ltd.—per square yard	10 2
30th Jan.	219	Heating—Z. D. Berry & Sons, Ltd.—plugs	17 16 0
30th Jan.	226	Woodwork—Andrew Bentley, Ltd.	57 0 0
30th Jan.	226	Playground—General Tarpaviors, Ltd.	688 16 0
		plus 2½%	
27th Feb. 1938.	334	Fencing—Prove Bros., Ltd.	153 4 4
18th July	866	Maintenance—Weighing Machines—W. E. Pollard and Son—per machine per annum	6 0
10th Oct.	1011	Conveyance—Dole Street to Bell Lane—Venture Transport (Hendon), Ltd.	£2 per coach, per day
10th Oct.	1033	Ditto Additional	10/- per day
5th Dec.	66	Conveyance—Mill Hill East to Sunningfields—L. Cronshaw, Ltd.	1 10 0
		per day	
10th Oct.	1011	Cleaning Curtains—Brent School—Scottish Dyers and Cleaners, Ltd.	16 0 0
10th Oct.	1022	Bell Lane School—Boundary Wall—Buckingham and Sons, Ltd.	414 0 0
10th Oct.	1023	Hyde School—Maintenance of Cooker—Gas Light and Coke Co.—per annum	2 0
10th Oct.	1021	Broadfields Avenue School—Quantity Surveyor—Mr. E. E. Richardson	Scale
10th Oct.	1033	British Film Institute—Membership to 30th June, 1939, only	5 5 0
10th Oct.	1037	National Association of Juvenile Employment and Welfare Officers—Membership to 31/3/39	1 1 0
5th Dec.	65	British Ship Adoption Society—Membership Subscription—16 Schools	50 8 0

QUOTATIONS ACCEPTED, CONTRACTS LET, ETC.—Contd.:

(24)

Date of Minute.	Minute Folio.	Particulars.	Amount of Contract.
1938.		Education—Contd.:—	
5th Dec.	79	Annual School Supplies:— Books—Foyles Educational, Ltd. Needlework—Cox & Co., and Leighton, Baldwin and Co., Ltd. Manual Woodwork—W. S. Fry, Ltd. Arts and Crafts—E. J. Arnold & Sons, Ltd., Dryad Handicrafts, Ltd., George & Co., Calipe, Dettmer & Co., Cox & Co., and J. B. Smith, Ltd. Stationery—E. J. Arnold & Co., Ltd.	£ s. d.
1939.			
30th Jan.	228	Edgware School—Quantity Surveyor—L. A. Francis and Sons.	Scale
27th Feb.	346	Annual Contracts:— Laundry—Colindale Laundry. Piano Tuning—Kirby's. Firewood—Church Army. Cleaning Materials—Kleen-e-zo Brush Co., Ltd.; J. Salmon & Sons, Ltd., and Middleton Bros., Ltd.	
27th Feb.	347	Coal and Coke—Fueer & Co., Ltd.; Gas Light and Coke Co., and C. Franklin, Ltd.	
27th March	466	Fire Extinguishers—All Schools—S. Dixon & Son, Ltd. (Builders work, £50)	232 13 3
27th March	481	Broadfields Avenue Junior and Infant School—Erection—A. McClelland & Co., Ltd.	24512 18 0
1938.		Highways:—	
9th May	734	Woodfield Avenue, 2nd Section—D. R. Paterson, Ltd.	1652 2 0
9th May	605	Green Walk—D. R. Paterson, Ltd.	1798 8 5
20th June	738	Cool Oak Lane Improvement—Chas. Carter	2742 7 11
10th Oct.	1055	Cool Oak Lane Improvement—Surfacing—Constable Hart & Co., Ltd.—per yard super	3/5 Less Credit 2/6 per ton clinker
20th June	738	Road Surface Dressings:— Asphalt Construction, Ltd. Situsec Ltd. T. Hill-Jones, Ltd.	6½d. per gallon delivered on Highways.
18th July	825	Footpath—Sturgess Avenue to Park Road—M. J. Glosson, Ltd.	738 0 6
		Accommodation Road—West Heath Drive to Finchley Road—F. C. Cooksley	552 12 10
18th July	826	Surfacing Engel Park, Woodfield Avenue and Green Walk—G. Wimpey & Co., Ltd.:— Carriageway—per square yard Footway Margins—per square yard	3 9 3 2
18th July	826	Surfacing Roads on Dole Street Housing Scheme—Highways Construction, Ltd.:— Carriageway—per square yard Footway Margins—per square yard	3 9 3 2
18th July	878	Traffic Lights—Walling Avenue, junction Orange Hill Road—Siemens & General Electric Railway Signal Co., Ltd.:— Installation Maintenance—1st year Maintenance—Future—per annum	514 10 0 26 10 0 50 4 0
5th Dec.	92	Public Lamps—Edgwarebury Lane—North Metropolitan Electric Power Supply Co.	98 14 0
5th Dec.	93	Finchley Road (Part) Resurfacing—Acme Flooring and Paving Co. (1904), Ltd.	34179 4 6

QUOTATIONS ACCEPTED, CONTRACTS, LET, ETC.—Contd.:

Date of Minute.	Minute Folio.	Particulars.	Amount of Contract.		
1939.		Highways (Contd.):—	£	s.	d.
30th Jan.	201	Private Street Improvements—Geo. Wimpey & Co., Ltd.—Devonshire Road and Crescent, Aberdare and Osborne Gardens.	6658	15	0
30th Jan.	254	Vivian Avenue—Lighting—North Middlesex Gas Co. (Annual Maintenance £176 16s. 0d.)	420	0	0
30th Jan.	255	Edgwarebury Lane—Lighting—North Metropolitan Electric Power Co. (Annual Maintenance £144 18s. 0d.)	124	14	0
30th Jan.	257	Abercorn Road—Fencing Plots	121	7	9
27th Feb.	359	Cricklewood Lane Reconstruction—Acme Flooring and Paving (1904) Co., Ltd.	18004	6	6
27th Feb.	360	Edgwarebury Lane Improvement—G. Wimpey and Co., Ltd.	8691	7	7
27th Feb.	365	Various Annual Contracts for Supplies and Services—Sundry Firms.			
27th March	496	Surfacing—Station Road, Edgware—G. Wimpey and Co., Ltd.—per square yard		6	8
1938.		Works and Fire Brigade:—			
9th May	623	Austin 18 h.p. Ambulances (2)—Mebes & Mebes, Ltd.	870	0	0
20th June	752	Mill Hill Depot—Sub-Contract—Weighbridge—W. and T. Avery, Ltd. (£20 per annum maintenance)	520	0	0
20th June	753	Queens Road Convenience—Sub-Contracts:—			
18th July	896	Steel Windows, etc.—Mellowes & Co., Ltd.	223	0	4
10th Oct.	980	Tile Flooring—Caxton Floors, Ltd.	74	1	3
10th Oct.	981	Sanitary Fittings—J. Bolding & Sons, Ltd.	238	9	1
10th Oct.	981	Doors—S. Elliott (Reading), Ltd.	34	16	6
10th Oct.	981	Ironmongery—W. N. Froy & Sons, Ltd.	44	17	3
18th July	896	Electric Lighting—S. V. Knight	42	12	6
		Flooring—Marble Mosaic Co., Ltd.	282	12	5
		Edgware Main Drainage—Second Section—D. R. Paterson, Ltd.	9611	13	7
		Bedford Truck—Spurling Motors, Ltd.	308	5	0
		Maintenance — Ambulance Box — Standard Telephones & Cables, Ltd.—additional per quarter			2 0
5th Dec. 1939.	35	Dust Destructor—Boiler—Wm. Moss & Sons, Ltd.			Day Work
30th Jan.	215	28 h.p. Austin Car—H. A. Saunders, Ltd.	365	8	0
30th Jan.	263	Fire Engine—Leyland Motors, Ltd.	1998	0	0
30th Jan.	266	Middlesex County Council—Rats Destruction—Land at Sewage Works and Dust Destructor—per annum		20	0 0
27th Feb.	388	North Circular Road—Sewer—A. Robinson	4254	1	2
27th Feb.	389	3 Cars—Mebes & Mebes	538	10	6
27th Feb.	389	Various Annual Contracts for Supplies and Services—Sundry Firms.			
27th March	508	Firemen's Boots—Wilkins & Denton, Ltd.	41	15	0
27th March	508	Fire Alarms, Additional Rental per annum—London Telephone Service		8	8 0
27th March	512	Lease of Stables and Cottages to the Middlesex County Council—exclusive	200	0	0
27th March	513	Clinker Machine—Chaseside Engineering Co., Ltd.	475	0	0
27th March	514	Veterinary Services—W. M. Aulton—per horse, per annum		15	0
27th March	514	Harness Repairs—W. H. Gidden, Ltd.—per set, per annum		1	18 0

QUOTATIONS ACCEPTED, CONTRACTS LET, ETC.—Contd.:

Date of Minute.	Minute Folio.	Particulars.	Amount of Contract.
1938.		Buildings and Town Planning:—	
18th July	917	Reproduction of Scheme No. 1 (500 copies) Ordnance Survey	£ s. d. 207 17 0
10th Oct. 1939.	977	Preparation of Scheme No. 2—Cook, Hammond and Kell, Ltd.	57 0 0
27th March	526	National Housing and Town Planning Council— Subscription	5 5 0
1938.		Estates, Parks and Allotments:—	
10th Oct.	1063	Street Trees—W. C. Slocock, Ltd.	various
10th Oct.	1064	Stone Grove Tarspraying Tennis Courts—Constable Hart & Co., Ltd.	96 0 0
1939.			
27th Feb.	379	Band Performances—9th Battalion, The Middlesex Regiment; Child's Hill Silver Band, and Hendon Salvation Army Band.	
27th Feb.	380	Sale of Refreshments—Bonds Restaurants Ltd.; J. Manners, and Mrs. A. O'Dell.	
27th Feb.	381	Montrose Allotments—Fencing, Gate and Water Supply	210 0 0
27th Feb.	382	Deans Lane Allotments—Water Supply	130 0 0
27th March	505	Deans Lane Allotments—Tree Lopping	33 8 6
27th March	500	Woodcroft Park—Public Convenience—J. N. Jones	590 0 0
1938.		Libraries:—	
10th Oct.	1076	Mill Hill—Magazines and Periodicals—S. G. Notley	discounts as permitted
5th Dec.	117	Golders Green—Magazines and Periodicals—W. Noble & Co., Ltd.	discounts as permitted
		Finance and General Purposes:—	
10th Oct.	1111	National Safety First Association—Membership to 31st October, 1939	10 10 0
5th Dec.	31	Loan—Co-operative Insurance Society, Ltd.:— £10000: 10 years	3½% per annum
		Loan—Royal Liver Friendly Society:— £10000: 39 years £25000: 49 years £35000: 25 years	3½% per annum
1939.			
27th March	557/8	Printing and Stationery per Schedule—Various Firms.	
		Public Health and Medical Services:—	
5th Dec.	29	Oxygen Tent Service—Hire of Tent	£25 per annum
1939.			
30th Jan.	242	Industrial Health Education Society—Subscription	2 2 0
27th March	485	X-Ray Examination Ante-Natal Cases—Hendon Cottage Hospital—per case	7 6
		Better Health Journal—Grant	12 0 0
27th March	486	Sundry Supplies to Isolation Hospital under Half-Yearly Contracts—Various Firms.	
27th March	488		
		Air Raid Precautions:—	
30th Jan.	299	Thermostatic Electric Heaters for Respirator Store	115 8 0
30th Jan.	300	Racks and Hooks for Anti-Gas Clothing	70 0 0
30th Jan.	304	Uniform Clothing—Auxiliary Fire Service	665 12 6

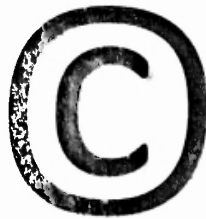

These digital images are
the copyright of
The London Borough of
Barnet 2017

Th
in
day
Bur
Cou



Borough of Hendon.

NOTICE IS HEREBY GIVEN

That a **Special Meeting** of the Council of the Borough of Hendon, in the County of Middlesex, will be held on **Monday** next, the **12th** day of **June, 1939**, at **6** o'clock in the afternoon, at the Town Hall, The Burroughs, Hendon, N.W. 4, and all and several the Members of the said Council are hereby summoned to attend.

The business to be transacted at such meeting is as follows:—

1. To confirm Minutes of the Ordinary Meeting of the Borough Council, held on the 8th May, 1939.
2. Official Announcements.
3. Mayor's (Whitsun) Recess Report (*to follow*).

Town Clerk.

Town Clerk's Office,
Hendon, N.W. 4.
7th June, 1939.

D
E
F
G
H
I
J
K
L
M
N
O
P
Q
R
S
T
U
V
W

at

NO

MI

AP

DE

DI

Minutes.

At an Ordinary Meeting of the COUNCIL of the BOROUGH OF HENDON, held at the Town Hall, The Burroughs, Hendon, N.W. 4, on Monday, the 8th day of May, 1939, at 6 o'clock p.m.

PRESENT:

His Worship the Mayor (Councillor H. C. Potter, J.P., F.S.I.), in the Chair.

Aldermen:

**W. R. Clemens, F.C.A.,
J. J. Copestake, J.P.,
B. Flowers,**

**W. M. Maughan, J.P.,
B. J. Monro.
A. J. Reynolds, J.P.,**

**F. C. Rice.
R. A. B. Teare, M.B.E.**

Councillors:

**E. Arter, M.C., M.I.A.E.,
F. H. Bate,
T. K. Bridge,
F. J. Collins,
F. W. Gilpin,
A. W. Greville,
W. A. Hicks,**

**C. H. Hignett,
L. Hirshfield,
P. Lightfoot,
A. A. Naar, M.B.E.,
(Mrs.) F. E. Parvin,
G. Pinkney,
T. Pugh,**

**C. R. Richardson,
J. H. Rodway,
T. J. Scott,
W. H. N. Shakespeare,
M.C., A.F.C., J.P.,
H. P. Small,
C. F. Windust.**

NOTICE OF MEETING:

The Town Clerk read the notice convening the meeting.

MINUTES—CONFIRMATION:

Moved by Alderman Copestake, seconded by Alderman Teare, and

236.—RESOLVED—That the Minutes of the Special Meetings of the Borough Council held on the 17th and 24th April, 1939, be confirmed.

APOLOGIES FOR ABSENCE:

Apologies for absence were submitted on behalf of Alderman S. H. Egan, J.P. (Deputy Mayor), Councillors E. J. Cox, A. W. Curton, G. J. Pryke, F.I.A.C., A.M.I.S.E., and (Mrs.) M. Thomas.

DEPUTY MAYOR:

His Worship the Mayor reported that Alderman S. H. Egan (Deputy Mayor) was now making recovery from his illness as well as could be expected and that he desired to thank his colleagues on the Council for the messages of good will which he had received during his illness.

DEATH OF MRS. TIPPER:

His Worship the Mayor referred to the sad loss which Mr. L. A. Tipper, the representative of the "Hendon Times and Borough Guardian," had sustained through the death of his wife and it was agreed that the Town Clerk be directed to convey to Mr. Tipper the sincere sympathy of the Council in his sad bereavement.

DIVINE SERVICE—ST. PAUL'S CHURCH, MILL HILL:

His Worship the Mayor reported that he proposed officially to attend morning service at St. Paul's Church, The Ridgeway, Mill Hill, on Sunday next the 14th May at 11 o'clock and expressed the hope that the Members of the Council and their ladies would support him on this occasion.

GOLF MATCH:

The Mayor reported that as a friendly gesture to the neighbouring Borough of Finchley he had issued a challenge to the Mayor of Finchley to provide a Corporation Team for a Golf Match at his club, Oxhey, on June 20th next, the teams to be eight a side and one extra, and that he had put up a cup for competition. The Mayor also extended an invitation to non-players to visit the course.

CENTRAL WARD—CASUAL VACANCY:

Result of Election.

The Town Clerk submitted the following statement as to the result of the uncontested election of a Councillor for the Central Ward of the Borough held on the 25th April, 1939:—

I HEREBY CERTIFY AND RETURN that at the Election of a Borough Councillor for the Central Ward held on the 25th April, 1939, the following was elected without opposition for the period ending 1st November, 1940:—

Name of Councillor.	Address.	Description.
Turner Kirkland Bridge	18, Sherwood Road, Hendon, N.W. 4.	Company Director.

The declaration of Acceptance of Office prescribed by law has been duly made.

The Mayor extended a cordial welcome to Councillor T. K. Bridge, the newly-elected Member for the Central Ward.

CONGRATULATIONS TO COUNCILLOR A. A. NAAR, M.B.E.:

On behalf of the Council, His Worship the Mayor congratulated Councillor A. A. Naar, M.B.E., on his election as a Member of the Middlesex County Council for the Hendon East County Electoral Division.

VACANCIES ON STANDING COMMITTEES:

Moved by Alderman Reynolds, seconded by Alderman Teare, and

237.—RESOLVED—That Councillor T. K. Bridge be appointed to fill the vacancies on the following Standing Committees:—

Estates, Parks and Allotments Committee,
Libraries and Local Pensions Committee,
Housing Committee.

EDUCATION COMMITTEE:

REPORT NO. 1.

Moved by Alderman Copestake, seconded by Councillor Scott, and

238.—RESOLVED—That Report No. 1 of the Education Committee (Meeting held on the 25th April, 1939—Agenda, pages 643-654) be received.

Page 645—Item 2 (a)—Community Centres—Clitterhouse Estate.

On the motion of Councillor Collins, duly seconded, it was

239.—RESOLVED—That the above item be referred to the Estates, Parks and Allotments Committee for consideration.

ADOPTION OF REPORT: Moved by Alderman Copestake, seconded by Councillor Scott, and

- 240.—RESOLVED—**That Report No. 1 of the Education Committee in so far as it relates to matters requiring the confirmation of the Council be approved and adopted, as amended.**

REPORT NO. 2.

Moved by Alderman Copestake, seconded by Councillor Scott, and

- 241.—RESOLVED—**That Report No. 2 of the Education Committee (in Committee) (Meeting held on the 25th April, 1939—Agenda, pages 655-656) be received.**

AMENDMENT moved by Councillor Gilpin, seconded by Councillor Shakespeare:—

THAT Report No. 2 of the Committee be received with the exception of Item 1 on page 655 relating to the Broadfields Avenue Junior and Infant School.

After hearing a statement by the Chairman of the Education Committee to the intent that the difficulties had been removed and that there would be no delay in the matter, the amendment was withdrawn.

- 242.—Accordingly RESOLVED—**That Report No. 2 of the Education Committee be received.**

ADOPTION OF REPORT: Moved by Alderman Copestake, duly seconded, and

- 243.—RESOLVED—**That Report No. 2 of the Education Committee (in Committee) in so far as it relates to matters requiring the confirmation of the Council be approved and adopted.**

REPORT NO. 3.

Moved by Alderman Copestake, seconded by Councillor Scott, and

- 244.—RESOLVED—**That Report No. 3 of the Education Committee (Meeting held on the 2nd May, 1939—Agenda, page 657) be received.**

REPORT NO. 4.

Moved by Alderman Copestake, duly seconded:—

THAT Report No. 4 of the Education Committee (in Committee) (Meeting held on the 2nd May, 1939—page 658) be received.

After discussion, it was

- 245.—RESOLVED—**That Report No. 4 of the Education Committee (in Committee) be considered by the Council in Committee this evening.**

PUBLIC HEALTH AND MEDICAL SERVICES COMMITTEE:

Moved by Councillor Scott, seconded by Councillor Hirshfield, and

- 246.—RESOLVED—**That the report of the Public Health and Medical Services Committee (Meeting held on the 17th April, 1939—Agenda, pages 659-665) be received.**

ADOPTION OF REPORT: Moved by Councillor Scott, seconded by Councillor Bate, and

- 247.—RESOLVED—**That the report of the Public Health and Medical Services Committee be approved and adopted.**

HIGHWAYS COMMITTEE:

Moved by Alderman Rice, seconded by Councillor Arter, and

248.—RESOLVED—That the report of the Highways Committee (Meeting held on the 17th April, 1939—Agenda, pages 666-670) be received.

ADOPTION OF REPORT: Moved by Alderman Rice, seconded by Alderman Teare, and

249.—RESOLVED—That the report of the Highways Committee be approved and adopted.

ESTATES, PARKS AND ALLOTMENTS COMMITTEE:

Moved by Councillor Collins, seconded by Councillor (Mrs.) Parvin, and

250.—RESOLVED—That the report of the Estates, Parks and Allotments Committee (Meeting held on the 17th April, 1939—Agenda, pages 671-675) be received.

Pages 671/2—Item 3—Montrose Playing Fields—Running Track.

AMENDMENT moved by Alderman Clemens, seconded by Alderman Reynolds:—

THAT Recommendation (2) be deleted and the following substituted:—

That application be made to the Minister of Health for sanction to the borrowing of the sum of £1,375 for a period not exceeding 5 years as follows:—

	£
Cost of Works	1,340
Cost of raising loan	35
	<hr/>
	£1,375
	<hr/>

On submission, the amendment was declared **carried**.

251.—Accordingly RESOLVED—

- (1) That the plans and estimates amounting to £1,340 for the construction of the running track in Montrose Playing Fields be approved.
- (2) That application be made to the Minister of Health for sanction to the borrowing of the sum of £1,375 for a period not exceeding 5 years as follows:—

	£
Cost of Works	1,340
Cost of raising loan	35
	<hr/>
	£1,375
	<hr/>

Page 673—Item 7—Parks Tractor.

AMENDMENT moved by Alderman Clemens, seconded by Alderman Reynolds:—

THAT the following paragraph be added to the Committee's recommendation:—

- (3) That application be made for the consent of the Middlesex County Council for the transfer of the two old tractors for training purposes under the Air Raid Precautions Scheme.

The amendment on submission was declared **carried**.

252.—Accordingly **RESOLVED**—

- (1) **That the quotation of Spurling Motors amounting to £615 2s. 0d. be accepted.**
- (2) **That the Corporate Seal be affixed to any necessary documents.**
- (3) **That application be made for the consent of the Middlesex County Council for the transfer of the two old tractors for training purposes under the Air Raid Precautions Scheme.**

Page 675—Item 15—Archfields Allotments—Huts.

AMENDMENT moved by Alderman Clemens, seconded by Alderman Reynolds:—

THAT Recommendation (2) be deleted and the following substituted:—

“That an annual rent of 6/6d. per hut be charged.”

The amendment, on submission, was declared **carried**.

253.—Accordingly **RESOLVED**—

- (1) **That the design for single type huts for Archfields Allotments be approved.**
- (2) **That an annual rent of 6/6d. per hut be charged.**

ADOPTION OF REPORT: Moved by Councillor Collins, seconded by Alderman Teare, and

254.—**RESOLVED**—**That the report of the Estates, Parks and Allotments Committee as amended be approved and adopted.**

WORKS AND FIRE BRIGADE COMMITTEE:

Moved by Alderman Reynolds, seconded by Councillor Windust, and

255.—**RESOLVED**—**That the report of the Works and Fire Brigade Committee (Meeting held on the 24th April, 1939—Agenda, pages 676-681) be received.**

Page 676—Item 4—Resignation of Firemen.

AMENDMENT moved by Alderman Clemens, seconded by Councillor Arter:—

THAT the following be added to the Committee's Recommendation:—

- (2) That the Fire Superintendent be authorised to issue certificates of approved service under Section 6 of the Fire Brigade Pensions Act, 1925, and the Council consent to the transfers.

The amendment, on submission, was declared **carried**.

256.—Accordingly **RESOLVED**—

- (1) **That the arrangements for filling the vacancies be referred to the Chairman (Councillor A. A. Naar, M.B.E.) and the Fire Superintendent, with power to act.**
- (2) **That the Fire Superintendent be authorised to issue certificates of approved service under Section 6 of the Fire Brigade Pensions Act, 1925, and the Council consent to the transfers.**

Page 677—Item 7—London Professional Fire Officers' Board.

AMENDMENT moved by Alderman Clemens, seconded by Councillor Arter:—

THAT the matter be referred back.

The amendment, on submission, was declared **carried**.

- 257.—Accordingly **RESOLVED—That Item 7 of the report of the Works and Fire Brigade Committee be referred back.**

(The reception of the further items in the Committee's Report was moved by the Chairman of the Committee (Councillor Naar).)

Page 680—Item 23—Public Telephone Kiosk.

AMENDMENT moved by Alderman Clemens, seconded by Councillor Arter:—

THAT the matter be referred back for further consideration and for further report by the Borough Surveyor on the lines indicated.

The amendment, on submission, was declared **carried**.

- 258.—Accordingly **RESOLVED—That Item 23 of the report of the Works and Fire Brigade Committee be referred back for further consideration and for further report by the Borough Surveyor on the lines indicated.**

ADOPTION OF REPORT: Moved by Councillor Naar, seconded by Councillor (Mrs.) Parvin, and

- 259.—**RESOLVED—That the report of the Works and Fire Brigade Committee, as amended, be approved and adopted.**

LIBRARIES AND LOCAL PENSIONS COMMITTEE:

Moved by Councillor Lightfoot, seconded by Councillor Scott, and

- 260.—**RESOLVED—That the report of the Libraries and Local Pensions Committee (Meeting held on the 24th April, 1939—Agenda, pages 682-683) be received.**

ADOPTION OF REPORT: Moved by Councillor Lightfoot, seconded by Councillor Scott, and

- 261.—**RESOLVED—That the report of the Libraries and Local Pensions Committee be approved and adopted.**

HOUSING COMMITTEE:

Moved by Councillor Gilpin, seconded by Alderman Flowers, and

- 262.—**RESOLVED—That the report of the Housing Committee (Meeting held on the 24th April, 1939—Agenda, pages 684-688) be received.**

Page 687—Item 13—Brent Hill Housing Scheme—120 Houses.

AMENDMENT moved by Councillor Windust, seconded by Councillor Arter:—

THAT the above item be referred back for further consideration.

After discussion, the amendment was submitted and declared **lost**.

AMENDMENT moved by Alderman Clemens, seconded by Alderman Reynolds:—

THAT Recommendation No. 2 be deleted and the following substituted:—

That the plans and estimates be approved and submitted to the Minister of Health with an application for a subsidy under the Housing (Financial Provisions) Act, 1938, and for consent to the borrowing of the following loans:—

Houses	£19,570	For a period not exceeding 60 years.
Roads	£7,000	For a period not exceeding 20 years.
Sewers	£3,200	For a period not exceeding 30 years.

The amendment, on submission, was declared **carried**.

263.—Accordingly **RESOLVED**—

- (1) That the suggested allocation, viz.: 90 houses of the 2-bedroom type and 30 of the 3-bedroom type be approved and that any previous resolution of the Council inconsistent herewith be varied accordingly.
- (2) That the plans and estimates be approved and submitted to the Minister of Health with an application for a subsidy under the Housing (Financial Provisions) Act, 1938, and for consent to the borrowing of the following loans:—

Houses	£49,570	For a period not exceeding 60 years.
Roads	£7,000	For a period not exceeding 20 years.
Sewers	£3,200	For a period not exceeding 30 years.

- (3) That an application be now submitted to the Minister of Health for consent to the appropriation, from sewage disposal, of 12.6 acres to housing and that any resolutions of the Council inconsistent herewith be varied accordingly.
- (4) That upon receipt of the Minister's instrument of appropriation the allotment tenancies on 12.6 acres Brent Hill Temporary Allotments be determined by re-entry on three months' notice in writing to expire on a date to be fixed by the Housing Committee in relation to their building programme.
- (5) That recommendations (3) and (4) above be regarded as matters of urgency and reported for information to the Estates, Parks and Allotments Committee.

ADOPTION OF REPORT: Moved by Councillor Gilpin, seconded by Alderman Teare, and

264.—**RESOLVED**—That the report of the Estates, Parks and Allotments Committee, as amended, be approved and adopted.

BUILDINGS AND TOWN PLANNING COMMITTEE:

Moved by Councillor Hignett, seconded by Alderman Reynolds, and

265.—**RESOLVED**—That the report of the Buildings and Town Planning Committee (Meeting held on the 24th April, 1939—Agenda, pages 689-702) be received.

ADOPTION OF REPORT: Moved by Councillor Hignett, seconded by Councillor Collins, and

266.—**RESOLVED**—That the report of the Buildings and Town Planning Committee be approved and adopted.

RATING AND VALUATION COMMITTEE:

Moved by Councillor Small, seconded by Councillor Windust, and

267.—**RESOLVED**—That the report of the Rating and Valuation Committee (Meeting held on the 2nd May, 1939—Agenda, pages 703-704) be received.

AIR RAID PRECAUTIONS COMMITTEE:

Moved by Councillor Arter, seconded by Councillor (Mrs.) Parvin, and

268.—**RESOLVED**—That the report of the Air Raid Precautions Committee (Meeting held on the 24th April, 1939—Agenda, pages 705-709) be received.

Page 705—Item 1—Multi-Purpose Buildings.

AMENDMENT moved by Alderman Clemens, seconded by Alderman Reynolds:—

THAT the following paragraph be added to the Committee's recommendation:—

That application be made to the Minister of Health for sanction to the borrowing for the maximum period available of the sum of £29,000, made up as follows:—

Buildings—£9,270 x 3	£
						£27,810
Quantity Surveyor's Fees		556
Clerk of Works		350
Plans, loan charges, etc.		284

					Total	£29,000

The amendment, on submission, was declared **carried**.

269.—Accordingly **RESOLVED**—

- (1) **That the Borough Surveyor be instructed to prepare plans and estimates and advertise for tenders for the erection of the three multi-purpose buildings forthwith.**
- (2) **That application be made to the Minister of Health for sanction to the borrowing for the maximum period available of the sum of £29,000, made up as follows:—**

Buildings—£9,270 x 3	£
						£27,810
Quantity Surveyor's Fees		556
Clerk of Works		350
Plans, loan charges, etc.		284

					Total	£29,000

Page 706—Item 4—Provision of Further Trenches.

On consideration of the above item, the Town Clerk reported that, as intimated to the Committee, he had been in communication with the Middlesex County Council pointing out that in this area there would not appear to be sufficient basements suitable for adaptation as shelters for persons who may be caught in the streets during a raid and making application for approval to the provision of further trenches to provide accommodation up to 10 per cent. of the population of the Borough.

A letter had now been received from the Middlesex County Council transmitting a copy of a letter from the Home Office (A.R.P. Department) stating that in due course supplies of the householders steel shelter and of the appliances for strutting private basements would be supplied to the Borough. The letter further stated that communal shelters should, in the Lord Privy Seal's view, be provided as far as possible by the use, with adaptation where necessary, of basements, cellars, etc. The Lord Privy Seal appreciated, however, that in an area such as Hendon basements, cellars, etc., may be few and some further trench construction may be necessary. He accordingly agreed to the construction of such further trenches as may be necessary after basements have been exhaustively surveyed, in a scheme of communal shelters to cater for 10 per cent. of the population of the Borough.

Noted.

Page 706—Item 6—Co-opton on Air Raid Precautions Committee.

Moved by Councillor Richardson, seconded by Alderman Flowers:—

THAT paragraphs (b) and (c) of the Committee's recommendation hereon be amended to the intent that the respective organisations referred to in the resolution be asked to nominate a representative.

The amendment, on submission, was declared **carried**.

270.—RESOLVED **accordingly**.

Page 708—Item 16—Appointment of Chief Air Raid Warden.

On consideration of the above item, the Town Clerk reported a letter, dated the 3rd May, from the Conference of Ratepayers' Associations of Hendon in the following terms:—

"The delegates to this Conference at their last meeting, were perturbed at the inability of the Council to appoint at the meeting on Monday, April 24th, 1939, the Chief Air Raid Warden for the Borough.

As the Mayor stated that this is an urgent matter, the Ratepayers of the Borough cannot understand the significance of again deferring the appointment of a suitable candidate, especially as the wardens of Hendon were asked to ballot for their leader, and had made known their selection.

I am instructed to ask that you bring to the notice of the Council, the anxiety with which this Conference feels about the matter, and to urge that the Chief Air Raid Warden be appointed without delay."

AMENDMENT moved by Alderman Reynolds, seconded by Councillor Gilpin:—

THAT recommendations (a) and (b) be deleted and the following substituted therefor:—

That Mr. T. K. Bridge be appointed Chief Air Raid Warden.

Debate ensued.

The amendment on submission was declared **lost**, whereupon a division was demanded by Alderman Reynolds and two other Members and taken with the following result:—

For 5.		Against 21.		Abstained from Voting 3.		Absent when Division taken 7.	
Alderman Reynolds.	Alderman Reynolds.	Alderman Clemens.	The Mayor.	The Deputy Mayor.		Councillor Connell.	
Councillor Bridge.	" Copestake.	" Alderman Monro.	Alderman Monro.	Councillor Connell.		Councillor Connell.	
" Gilpin.	" Flowers.	Councillor Small.	Councillor Small.	" Cg.	" Curton.	" Griffiths.	" Pryke.
" Lightfoot.	" Maughan.			" (Mrs.) Thomas.	" Pryke.	" (Mrs.) Thomas.	" (Mrs.) Thomas.
" (Mrs.) Parvin.	" Rico.						
	" Teare.						
	Councillor Arter.						
	" Bate.						
	" Collins.						
	" Grevillo.						
	" Hicks.						
	" Hignett.						
	" Hirshfield.						
	" Naar.						
	" Pinkney.						
	" Pugh.						
	" Richardson.						
	" Rodway.						
	" Scott.						
	" Shakespeare.						
	" Windust.						

ADOPTION OF REPORT: Moved by Councillor Arter, seconded by Councillor Scott, and

271.—RESOLVED—That the report of the Air Raid Precautions Committee, as amended, be approved and adopted.

FINANCE AND GENERAL PURPOSES COMMITTEE:

Moved by Alderman Clemens, seconded by Alderman Rice, and

- 272.—RESOLVED—That the report of the Finance and General Purposes Committee (Meeting held on the 1st May, 1939—Agenda, pages 710-752) be received.

Page 718—Item 31—Ravensfield.

AMENDMENT moved by Councillor Arter, seconded by Alderman Copestake:—

THAT the above matter be referred back and that the Town Clerk be instructed to report to the next meeting of the Air Raid Precautions Committee on the question of accommodation for the Air Raid Precautions Staff.

The amendment, on submission, was declared **carried**.

SUBSTANTIVE MOTION: Upon submission of the amendment as the substantive motion, it was declared **carried**.

- 273.—Accordingly RESOLVED—That Item 31 of the report of the Finance and General Purposes Committee be referred back and that the Town Clerk be instructed to report to the next meeting of the Air Raid Precautions Committee on the question of accommodation for the Air Raid Precautions Staff.

Page 719—Item 36—Standing Orders.

In reply to a question by Alderman Reynolds, the Town Clerk reported that the revised Standing Orders would come into operation as from the date of adoption by the Council, but that the various Committees would only be appointed in accordance with Standing Orders as from the date of the Annual Meeting.

ADOPTION OF REPORT: Moved by Alderman Clemens, seconded by Alderman Reynolds, and

- 274.—RESOLVED—That the report of the Finance and General Purposes Committee, as amended, be approved and adopted.

SEALING OF DOCUMENTS:

Moved by Alderman Rice, seconded by Alderman Teare, and

- 275.—RESOLVED—That the Corporate Seal be affixed to the following documents:—

Duplicate Conveyance	All Souls' College, Oxford, and the Corporation —of land at the junction of Brampton Grove and The Burroughs, Hendon.
Duplicate Conveyance	Mill Hill Homesteads Ltd., and the Corporation —of greensward opposite 8-14, Devonshire Crescent.
Agreement	The Corporation and Mr. E. E. Richardson—as to engagement of Quantity Surveyor in connection with Broadfields Avenue School.
Lease	The Corporation and Handley Page Limited— of land for use as a sports ground at Woodfield Park, Hendon.
Agreement	The Corporation and Sir Charles McRea—as to grazing rights — Arrandene Open Space, Hendon.
Transfers	Aubrey Bell Hewett, Esq., and others to the Corporation—of land on the south-west side of Hendon Wood Lane, Hendon.

EX-STATION OFFICER R. E. STIMPSON:

Moved by Alderman Clemens, seconded by Alderman Copestake:—

THAT the motion set out on the Agenda standing in the names of Alderman Maughan, Alderman Teare and Councillor Windust be considered by the Council in Committee.

The motion, on being submitted, was declared **carried**, whereupon a division was demanded by Alderman Maughan and two other members and taken with the following result:—

	For 18.	Against 8.	Abstained from Voting 2.	Absent when Division taken 8.
Alderman	Clemens.	Alderman Maughan.	The Mayor.	The Deputy Mayor.
"	Copestake.	" Teare.	Councillor Naar.	Alderman Reynolds.
"	Flowers.	Councillor Bridge.		Councillor Connell.
"	Monro.	" Pinkney.		" Cox.
"	Rice.	" Pugh.		" Curton.
Councillor	Arter.	" Richardson.		" Griffiths.
"	Bate.	" Rodway.		" Pryke.
"	Collins.	" Windust.		" (Mrs.) Thomas.
"	Gilpin.			
"	Greville.			
"	Hicks.			
"	Hignett.			
"	Hirshfield.			
"	Lightfoot.			
"	(Mrs.) Parvin.			
"	Scott.			
"	Shakespeare.			
"	Small.			

276.—Accordingly **RESOLVED**—That the motion set out under Item 9 of the Agenda be considered by the Council in Committee this evening.

WHITSUN RECESS:

Moved by Alderman Teare, duly seconded, and

277.—**RESOLVED**—That His Worship the Mayor, or in his absence the Deputy Mayor, be vested with power to deal with any urgent matters which may arise during the Whitsun Recess, i.e., 23rd May to the 12th June.

ADJOURNMENT:

At 7.43 p.m., on the motion of the Mayor, the Council adjourned to 7.53 p.m. this day to be resumed in Committee.

Herbert G. Potter

Mayor.

Council in Committee

8th May, 1939.

PRESENT:

His Worship the Mayor (Councillor H. G. Potter, J.P., F.S.I.), in the Chair.

Aldermen:

**J. J. Copestake, J.P.,
B. Flowers,**

**W. M. Maughan, J.P.,
A. J. Reynolds, J.P.,**

**F. C. Rice,
R. A. B. Teare, M.B.E.**

Councillors:

**E. Arter, M.C., M.I.A.E.,
F. H. Bate,
T. K. Bridge,
F. J. Collins,
F. W. Gilpin,
A. W. Greville,
W. A. Hicks,**

**G. H. Hignett,
L. Hirshfield,
P. Lightfoot,
A. A. Naar, M.B.E.,
(Mrs.) F. E. Parvin,
C. Pinkney,
T. Pugh,**

**G. R. Richardson,
J. H. Rodway,
T. J. Scott,
W. H. N. Shakespeare,
M.C., A.F.C., J.P.,
H. P. Small,
C. F. Windust.**

EDUCATION COMMITTEE—REPORT NO. 4:

278.—RESOLVED—That **Report No. 4 of the Education Committee (in Committee)** (Meeting held on the 2nd May, 1939—Agenda, page 658) be received.

Air Raid Precautions in Schools.

After hearing a statement by the Chairman of the Education Committee (Alderman Copestake) on the matters referred to in the Committee's Report it was moved by Alderman Reynolds, seconded by Alderman Flowers, and

279.—RESOLVED—That **Report No. 4 of the Education Committee (in Committee)** be approved and adopted.

Deputation to the Ministry of Health.

The Members forming the deputation to the Ministry of Health on the matters referred to in Report No. 4 of the Education Committee agreed that the Director of Education be directed to arrange for the deputation to be received at 12 noon if possible.

EX-STATION OFFICER STIMPSON—NOTICE OF MOTION:

The following motion, notice of which had been given in accordance with Standing Order No. 7, was moved by Alderman Maughan, seconded by Alderman Teare:—

THAT the Council's resolution (18/7/38), in reference to ex-Station Officer Stimpson, be rescinded and that Mr. R. E. Stimpson be re-instated as Station Officer in Hendon Fire Brigade.

Debate ensued.

AMENDMENT moved by Councillor Gilpin, seconded by Alderman Rice:—

THAT the Works and Fire Brigade Committee be instructed to submit a full report on the matter to the Council.

Debate continued.

SUSPENSION OF STANDING ORDER NO. 4:

At 9.55 p.m., motion moved by Alderman Flowers, seconded by Alderman Copestake, and

280.—

RESOLVED—That for the purposes of this meeting of the Borough Council, Standing Order No. 4 be suspended.

After further discussion, the amendment was submitted and declared **lost**.

The motion was thereupon submitted and declared **lost**, whereupon a division was demanded by Councillor Pugh and two other members and taken with the following result:—

For 6.	Against 18.	Abstained from Voting 1.	Absent when Division taken 11.
Alderman Maughan.	Alderman Copestake.	The Mayor.	The Deputy Mayor.
Teare.	Flowers.		Alderman Clemens.
Councillor Pugh.	Reynolds.		Monro.
Richardson.	Rice.		Councillor Bridge.
Rodway.	Councillor Arter.		Councillor Connell.
Windust.	Bate.		Cox.
	Collins.		Curton.
	Gilpin.		Griffiths.
	Greville.		Pinkney.
	Hicks.		Pryke.
	Hignett.		(Mrs.) Thomas.
	Hirshfield.		
	Lightfoot.		
	Naar.		
	(Mrs.) Parvin.		
	Scott.		
	Shakespeare.		
	Small.		

The meeting terminated at 10.35 p.m.

Herbert J. Potter
Mayor.

D
E
F
G
H
I
J
K
L
M
N
O
P
Q
R
S

T
in
d
E
C



Borough of Hendon.

NOTICE IS HEREBY GIVEN

That a Statutory Meeting of the Council of the Borough of Hendon, in the County of Middlesex, will be held on **Monday** next, the **19th** day of **June, 1939**, at **6** o'clock in the afternoon, at the Town Hall, The Burroughs, Hendon, N.W. 4, and all and several the Members of the said Council are hereby summoned to attend.

The business to be transacted at such meeting is as follows:—

1. To confirm Minutes of the Special Meeting of the Borough Council held on the 12th June, 1939.
2. Official Announcements.
3. Questions.
4. To approve, or otherwise, the Reports of the following Committees, viz.:—
 - Education; Public Health and Medical Services; Highways; Estates, Parks and Allotments; Works and Fire Brigade; Libraries and Local Pensions; Housing; Buildings and Town Planning; Rating and Valuation; Air Raid Precautions; and Finance and General Purposes.
5. To authorise the sealing of the following documents:—

Agreement and Transfer	J. B. Hider, Esq. and Another, and the Corporation— <i>re</i> dedication of land abutting on Hendon Wood Lane.
Deed of Apprenticeship	Mr. F. E. Wicks and R. J. Wicks, Junior, and the Corporation—for training and instruction in gardening.
Conveyance	The Trustees of the Will of J. C. Williamson, deceased, to the Corporation— <i>re</i> land at junction of Dollis Road and Thornfield Avenue, Hendon.
Agreement and Transfer	T. W. Heath (Neasden) Limited and the Corporation— <i>re</i> transfer of land at Crossway.
6. Reports (if any) of Officers.

Town Clerk

Town Clerk's Office,
Hendon, N.W. 4.
14th June, 1939.

Town Clerk.

INDEX.

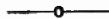

MINUTES Page 766 to 777

REPORTS:—

EDUCATION COMMITTEE „ 778 to 798

PUBLIC HEALTH & MEDICAL SERVICES COMMITTEE „ 799 to 804

HIGHWAYS COMMITTEE „ 805 to 808

ESTATES, PARKS & ALLOTMENTS COMMITTEE „ 809 to 813

WORKS & FIRE BRIGADE COMMITTEE „ 814 to 820

LIBRARIES & LOCAL PENSIONS COMMITTEE „ 821 to 822

HOUSING COMMITTEE „ 823 to 825

BUILDINGS & TOWN PLANNING COMMITTEE „ 826 to 838

RATING & VALUATION COMMITTEE „ 839

AIR RAID PRECAUTIONS COMMITTEE „ 840 to 869

FINANCE & GENERAL PURPOSES COMMITTEE „ 870 to 885

Minutes.

At a Special Meeting of the COUNCIL of the BOROUGH OF HENDON, held at the Town Hall, The Burroughs, Hendon, N.W. 4, on Monday, the 12th day of June, 1939, at 6 o'clock p.m.

PRESENT:

His Worship the Mayor (Councillor H. G. Potter, J.P., F.S.I.), in the Chair.

Aldermen:

J. J. Copestake, J.P.,
W. M. Maughan, J.P.,

A. J. Reynolds, J.P.,
F. C. Rice,

R. A. B. Teare, M.B.E.

Councillors:

E. Arter, M.C., M.I.A.E.,
T. K. Bridge,
F. H. Bate,
F. J. Collins,
H. Connell, J.P.,
A. W. Curton,
F. W. Cilpin,
A. W. Creville,

W. A. Hicks,
C. H. Hignett,
L. Hirshfield,
P. Lightfoot,
A. A. Naar, M.B.E.,
(Mrs.) F. E. Parvin,
C. Pinkney,

C. J. Pryke, F.I.A.C.,
A.M.I.S.E.,
T. Pugh,
C. R. Richardson,
W. H. N. Shakespeare,
M.C., A.F.C., J.P.,
C. F. Windust.

NOTICE OF MEETING:

The notice convening the meeting was read.

MINUTES—CONFIRMATION:

Moved by Alderman Copestake, seconded by Councillor Bate, and

281.—RESOLVED—That the Minutes of the Ordinary Meeting of the Borough Council held on the 8th May, 1939, as amended by the substitution of the words "Housing Committee" for the words "Estates, Parks and Allotments Committee" in Resolution No. 264 appearing on page 759 of the Minutes be confirmed.

APOLOGIES FOR ABSENCE:

Apologies for absence were submitted on behalf of Aldermen S. H. Egan, J.P. (Deputy Mayor), W. R. Clemens, F.C.A., B. Flowers and B. J. Monro, and Councillor E. J. Cox.

DEPUTY MAYOR:

His Worship the Mayor reported a letter from Alderman S. H. Egan, J.P. (Deputy Mayor) intimating that he was at Sudbury, Suffolk, recuperating from his illness and expressing his thanks to the Mayor, his colleagues on the Council, and the Members of the Staff for their kind enquiries and wishes for a speedy recovery, which he and Mrs. Egan much appreciated.

ILLNESS OF ALDERMAN BROOK FLOWERS:

The Mayor informed the Council with regret that Alderman Brook Flowers was not progressing as well as was anticipated and read a letter from Mrs. Brook Flowers thanking the Mayor and the Members of the Council for their kind messages of sympathy.

282.—RESOLVED—That His Worship the Mayor be asked to convey to Mrs. Brook Flowers, on behalf of the Council, their sincere sympathy and good wishes for Alderman Brook Flowers' speedy recovery.

RECESS (WHITSUN) REPORT:

283.—RESOLVED—That the following report be received:—

To the Aldermen and Councillors,
Borough of Hendon.

Ladies and Gentlemen,

RECESS (WHITSUN) REPORT.

The following matters have been dealt with under authority of the Council's resolution No. 277 of the 8th May:—

1.—OLD AGE PENSIONS:

3 Claims at the full rate have been allowed.

2.—COMMITTEES' REPORTS:

The following items from the proceedings of the Committees indicated were submitted to me and the recommendations confirmed:—

(A). *Air Raid Precautions Committee.*
16th and 30th May, 1939.

(1) **Air Raid Precautions—Headquarters:**

It will be recalled that the Council on the 8th May referred back the recommendation of the Finance and General Purposes Committee allocating Derby House, Parson Street, as Air Raid Precautions Headquarters, and agreed that after further consideration by the Air Raid Precautions Committee the Mayor should take the necessary action during the Recess. As a matter of urgency the Committee have given consideration to the question and have received reports from the Chairman arising out of his inspection of Nos. 1 and 2, Ravensfield and Derby House, and the Town Clerk indicating the circumstances in which the Finance and General Purposes Committee recommended the allocation of Derby House as the future Air Raid Precautions Headquarters.

The Town Clerk pointed out that owing to the expansion of the Air Raid Precautions services the accommodation available at No. 2, Ravensfield is now insufficient, whereas accommodation is available at Derby House for the Air Raid Precautions Officer and his staff, the Central Divisional Warden, the Chief Warden (when appointed), also good lecture rooms and storage facilities in the basement.

As an alternative to Derby House, consideration was given to the possibility of taking over No. 1, Ravensfield (now used as the Hendon Divisional Headquarters of the British Red Cross Society) in addition to No. 2, Ravensfield and providing accommodation elsewhere for the British Red Cross Society. It was intimated that the County Council would not recognise as Air Raid Precautions expenditure the rental of premises solely for the purpose of British Red Cross Headquarters.

The rent charged to Air Raid Precautions account in respect of No. 2, Ravensfield (which has been approved by the District Valuer) is £195 per annum, and as the accommodation of No. 1, Ravensfield is similar it is assumed that a like rental would be charged to the account, making a total of £390 per annum. The District Valuer had approved a rental of £208 for Derby House, and the Middlesex County Council had intimated their approval to the user of the premises at this rental.

The Committee have given very full consideration to the question in all its bearings, and as there is not sufficient accommodation available in the Town Hall they are of opinion that the Air Raid Precautions Officer and his staff should be housed as near as possible to the Town Hall and the Central Control Headquarters at the Hendon Technical Institute. They accordingly

RESOLVED TO RECOMMEND—

- (a) That in addition to No. 2, Ravensfield, the adjoining premises No. 1 be taken over for Air Raid Precautions purposes and that the Air Raid Precautions Officer and his staff be housed at Ravensfield;
- (b) That application be made to the Middlesex County Council for approval to the proposal and to a rental of £195 per annum being charged to Air Raid Precautions Account in respect of No. 1, Ravensfield;
- (c) That the Town Clerk be instructed to negotiate with the British Red Cross Society with a view to their transferring to Derby House at the earliest practicable date;
- (d) That if the British Red Cross Society finds the accommodation at Derby House unsuitable for their purposes, Burroughs House be considered as an alternative;
- (e) That pending possession of No. 1, Ravensfield being obtained, the Air Raid Precautions Officer and his staff be accommodated in No. 2, Ravensfield;
- (f) That a report be submitted by the Town Clerk in a month's time as to the transfer of the whole of the Administrative Air Raid Precautions Staff.

[Addendum: In connection with the transfer of the Hendon Division of the British Red Cross Society from "Ravensfield," it was reported that the Society had recently incurred expenses on redecoration, etc. I have had the work valued by the Borough Surveyor and, subject to the production of vouchers, the estimated expenditure amounts to £70.

On the understanding that all lino, curtains, fittings, etc., are retained at "Ravensfield" as the property of the Council and subject to the supporting vouchers referred to, I have authorised payment up to this amount on any expense of redecoration, etc., which the Society may incur on taking up occupation of Derby House.]

(2) Report of Air Raid Precautions Officer:

(a). *Empire Air Day Display.*

The Air Raid Precautions Officer reported that arrangements were made with the Royal Air Force Authorities for the Borough to provide an Air Raid Precautions exhibition as part of the Empire Air Display which took place at the Aerodrome on the 20th May. The general public were given an opportunity of seeing all equipment, etc., and to obtain information on all matters relating to the Air Raid Precautions services. In addition, a Rescue Party and Demolition Squad, both fully equipped, and a trailer pump with crew, were on view, and his staff was in attendance for the purpose of enrolling volunteers. The exhibition attracted a large number of visitors and proved to be very popular.

RESOLVED TO RECOMMEND—That the arrangements made by the Air Raid Precautions Officer be confirmed, and authority given for the payment of certain incidental expenses amounting to 15/-.

(b). *Instruction and Advice to the Public.*

The Air Raid Precautions Officer drew attention to the importance of the general public being instructed in precautions which should be taken against air raids and suggested:—

- (i) That in each Division a demonstration gas-proof room and an exhibition room should be opened; a demonstration garden trench constructed and the correct method of sandbagging illustrated, and that at each of these centres information should be available on matters relating to Air Raid Precautions.
- (ii) That an "Anderson" shelter be erected in the grounds of Ravensfield at an estimated cost of £4.
- (iii) That a course of lectures be arranged for the public at which all necessary information and advice be given.
- (iv) That a card be issued to all householders as soon as the organisation is complete indicating the nearest Air Raid Warden's Post, together with telephone number; the nearest First Aid Post; a list of Public Shelters in the neighbourhood and the sirens from which aid raid warnings will be given.

RESOLVED TO RECOMMEND—That the proposals of the Air Raid Precautions Officer outlined above be approved and adopted and that he be authorised to take all necessary steps to give effect thereto.

(B). *Libraries and Local Pensions Committee.*
22nd May, 1939.

Proposed Film of "The Times" Newspaper:

In 1936 (Li.C., 15/6/36—8) the Central Library was selected to appear in the documentary film "Cover to Cover" which the Strand Film Company was commissioned to make for the National Book Council. The producer of the film (Mr. Paul Rotha) is now engaged on one for "The Times" newspaper and he seeks permission to take a few "shots" in one of the Council's Libraries.

RESOLVED TO RECOMMEND—That consent be granted.

(C). *Housing Committee.*
22nd May, 1939.

(1) Appointment of General Foreman:

The Committee interviewed the selected applicants. (Hsg.C., 24/4/39—12).

RESOLVED TO RECOMMEND—

- (a) **That Mr. James Henry Steeples, Supervisor of Repair Work, Buxton Borough Council, be appointed on the permanent staff to the post of General Foreman in connection with the maintenance of the Council's Housing Estates at a wage of £5 per week;**
- (b) **That as soon as practicable Mr. Steeples be granted the tenancy of a Council house.**

(Failing the appointment being taken up by Mr. Steeples, it was

RESOLVED—That the post be offered to Mr. A. Bennett, Foreman, Bury Borough Council.)

[Addendum: Mr. J. H. Steeples will take up his appointment on Monday, the 12th instant.]

(2) Dole Street Estate:

It was reported that only one vacant house existed on this Estate, the former tenant having been transferred to The Hyde.

The Committee further considered the case of Applicant No. 6599, together with the observations of the Housing Manager thereon.

RESOLVED TO RECOMMEND—That Applicant No. 6599 be allotted the vacant house on the Dole Street Estate.

(D).

Estates, Parks and Allotments Committee.
15th May, 1939.

(1) **Edgwarebury Park—The Life Boys:**

An application has been considered from The Life Boys for permission to use Edgwarebury Park for the purpose of their annual sports to be held on the 1st July next.

Approximately 250 boys between the ages of 9 to 12 years would be assembled under the supervision of adult leaders.

RESOLVED TO RECOMMEND—That the application be approved subject to the Council being fully indemnified against all costs and claims arising out of the user and an undertaking being given to make good any damage to the property.

(2) **Silk Stream Park—Refreshments:**

A tender was received from Mr. H. W. Daniel of 44, Greenway Gardens, Colindale, amounting to £2 for the right to sell refreshments in Silk Stream Park to the 31st March, 1940.

RESOLVED TO RECOMMEND—That the tender of Mr. H. W. Daniel amounting to £2 for a period of one year ending on the 31st March, 1940, be accepted.

(E).

Highways Committee.
15th May, 1939.

PRIVATE STREET WORKS.(1) **Service Road, Edgware Road, Hendon:**

The Borough Surveyor reported on a letter from The Varley Estates Ltd. who are constructing a service road in front of a block of shops at The Hyde, Edgware Road. The Minister of Transport has intimated that such service roads are not part of the trunk road for which he is responsible, and in these circumstances the Company desire to enter into an agreement with the Council in the usual standard form, relative to the making up and taking over of streets as public highways.

RESOLVED—That consideration of the matter be adjourned until the next meeting to enable the Borough Surveyor to communicate with the Minister of Transport thereon.

(2) **Roads, Broadfields Park Estate, Edgware:**

The Borough Surveyor reported to the effect that under an agreement, dated 4th June, 1937, Taylor Woodrow Construction Ltd. undertook to make up the under-mentioned roads:—

Kenilworth Road (Part of).
 Glengall Road (Part of).
 Marlborough Avenue (Part of).
 Wyre Grove.

Warwick Avenue (Part of).
 Morley Crescent.
 Aldridge Avenue.

The work of making up these roads was completed some time ago but difficulty has arisen owing to one of the roads being used for cartage purposes by another estate owner.

The Company point out that the delay in issuing the certificate of completion provided for in the agreement, is causing difficulties between them and their contractors, as the period of maintenance required by the agreement is automatically extended. The road which is suffering the most from the traffic referred to is Kenilworth Road in respect of which the Borough Surveyor is not prepared to issue a certificate of completion at the present time.

In order, however, to assist the firm concerned it is suggested that the roads above referred to be considered complete in accordance with the terms of the agreement, with the exception of Kenilworth Road (Part of) and that the period of maintenance of six months for the general work and two years for the surfacing, be allowed to commence as from the 1st March, 1939.

RESOLVED TO RECOMMEND—That the above suggestions be approved.

(3) Dedication of Private Streets:

It was reported that the under-mentioned streets had recently been made up and should now be dedicated as public highways repairable by the inhabitants at large:—

Chanetonbury Way—whole length.

Saddlecombe Way—whole length.

Engel Park—from its junction with Bittacy Hill to a line drawn between the western boundary fence of No. 9, Engel Park to the western boundary fence of No. 16, Engel Park.

Rectory Lane—whole length.

St. Albans Lane—whole length.

Pursley Road—from its junction with Dole Street to a point 900 feet in a south-westerly direction from Dole Street.

Brookfield Avenue—whole length.

Brookfield Close—whole length.

RESOLVED TO RECOMMEND—That the streets or portions of streets indicated above be now dedicated as public highways and the necessary notices duly posted.

PUBLIC LIGHTING.

(4) Edgware Road Improved Lighting between Rookery Way and Sheaveshill Avenue:

In connection with the reconstruction of the above section of the Edgware Road involving the provision of two carriageways, the Borough Surveyor reported that the scheme will necessitate a complete revision of the existing lighting system. Under the provisions of Section 6 of the Trunk Roads Act, 1936, the Minister is empowered to make grants towards improved lighting systems on trunk roads, and a scheme has accordingly been prepared to light both carriageways of the reconstructed road to the standard of Group "A" as laid down in the report of the Departmental Committee on Street Lighting. The Minister has signified his preliminary approval to the scheme. The provisional estimate of the cost is as follows:—

	£	s.	d.
Annual cost of providing and maintaining the new system, including the supply of gas thereto	755	0	0
Alterations to existing equipment	280	0	0

The Minister is prepared to pay 50 per cent. of both these sums, viz., £377 10s. 0d. per annum and £140 towards the alterations to the existing equipment.

RESOLVED TO RECOMMEND—That the scheme and estimate be approved and submitted to the Minister of Transport.

IMPROVEMENT SCHEMES.

(5) **Edgware Road Improvement between Rookery Way and Garrick Road, Hendon:**

The Borough Surveyor reported on a letter from the Ministry of Transport, in accordance with the agreement entered into, inviting the Council to prepare drawings, specifications and estimates of an improvement of the above section of the Edgware Road, including the reconstruction of the Silk Stream Bridge.

RESOLVED TO RECOMMEND—That such invitation be accepted and the Borough Surveyor authorised to arrange for the preparation of plans, specifications and estimates.

(6) **Sign, Junction of Farm Avenue and Cricklewood Lane:**

A letter was submitted from the Brondesbury Cricket Club asking for permission to place a sign on the lamp post at the corner of Farm Avenue and Cricklewood Lane, directing to the Club. In view of the policy of the Council prohibiting the erection of such signs, the Committee

RESOLVED TO RECOMMEND—That permission be not granted.

(7) **Surface Dressings:**

The Borough Surveyor asked for authority to enter into contracts for the supply of road surface dressings with the following firms:—

Asphalt Construction Ltd.
McCreath, Taylor & Co. Ltd.
Thos. Hill-Jones Ltd.
Situsec, Ltd.

The prices are all the same, viz., 6½d. per gallon, delivered.

RESOLVED TO RECOMMEND—That authority be given for the necessary contracts to be entered into with the firms in question and the Corporate Seal affixed to any necessary documents in connection therewith.

(F). *Works and Fire Brigade Committee.*
22nd May, 1939.

Motor and Fuel Oils—Annual Tenders:

The Borough Surveyor submitted a report on the tender of the Anglo-American Oil Company and as to the desirability of entering into a contract for supplies to cover various services of the Council.

RESOLVED TO RECOMMEND—That a contract be entered into with the Anglo-American Oil Company for the supply of fuel oil per schedule No. 8/4 (W. & F.B.C., 13/2/39) for Road Rollers, West Hendon Swimming Pool and Schools, and to purchase fuel oil from the Company for Pagefield Lorries at the wholesale schedule price ruling on the day of delivery, less a rebate of ¼d. per gallon.

(G). *Buildings and Town Planning Committee.*
22nd May, 1939.

Re-naming of (part of) Finchley Lane, Hendon:

The Borough Surveyor reported on a letter from the Borough of Finchley intimating that they propose to re-name as "Hendon Lane," Finchley Avenue, and suggesting that the name "Hendon Lane" should also apply to the section of the road between Great North Way and the Borough boundary (viz., the brook) and which at present is known as Finchley Lane. There would not appear to be any objection to the proposal, and the Committee

RESOLVED TO RECOMMEND—That the suggestion be approved and that notice be given of the Council's intention to make an Order under Section 18 of the Public Health Act, 1925, re-naming as "Hendon Lane" that portion of the road at present known as Finchley Lane, situate between Great North Way and the Borough boundary.

3.—LONDON GARDENS EXHIBITION:

I considered a letter received from the London Gardens Society regarding an exhibition to be held on the 8th and 9th September next at the Royal Horticultural Hall, Westminster, and having regard to the large amount of work which has to be done in the parks and open spaces during the summer months I gave authority for the promoters to be informed that the Council would be unable to stage an exhibition.

4.—EDGWAREBURY PARK, EDGWARE:

I considered a schedule of tenders (Appendix "A") received for the construction of a Pavilion and Lavatories in the above Park, and gave authority for the lowest tender, that of Mr. J. Norman Jones, amounting to £1,900 to be provisionally accepted.

I also gave authority for an application to be made to the Minister of Health for the necessary loan sanction, as follows:—

					£
Amount of provisionally accepted tender	1,900
Proportion of Clerk of Works' salary	30
Cost of raising loan	20
				Total	£1,950

5.—WATLING PARK—BANDSTAND:

Tenders (Appendix "B") received for the above were considered and authority given for the lowest tender, that of Messrs. G. H. Kempster Ltd. amounting to £479 3s. 1d. to be accepted, subject to the usual financial enquiries.

6.—SOUTHOVER, WOODSIDE PARK ESTATE:

A schedule of tenders (Appendix "C") received for the bituminous surfacing of the above road was submitted to me, and I gave authority for the lowest tender received, that of Messrs. Constable, Hart & Co. at 3s. 11d. per square yard, to be accepted.

The contract will provide for free maintenance for a period of two years.

7.—NO. 1 TALBOT AMBULANCE:

Owing to the above Ambulance being put out of commission as a result of the accident which occurred on the 20th ultimo, authority was given to disregard the Council's decision (W. & F.B.C., 24/4/39—14) to advertise for a new one and quotations were invited and received from local firms as follows:—

	Amount of Tender.	
	£	s. d.
E. V. Main & Co., 1, Hale Lane, N.W. 7	490	0 0
London Auto-Sales Co., 22, Broadway, N.W. 7	471	10 0
Mebes & Mebes Ltd., The Broadway, N.W. 7	465	5 6
"K" Garage & Service Station Ltd., Watford Way, N.W. 7	415	13 6

Authority was given for the lowest tender, that of "K" Garage & Service Station Ltd. to be accepted.

8.—TRANSFER OF PETROLEUM LICENCE:

Authority was given for the petroleum licence to store 5,000 gallons in bulk at Edgware Road, held by Sessions Motor Services (Holdings) Ltd., to be transferred to the North Road Service Station Syndicate Ltd.

9.—DEFECTIVE CASES:

Reports of the Medical Officer of Health in the above cases were dealt with as follows:—

E.R., Burnt Oak. 10/2/27. Woodcroft School.	General Debility.	Admission to a Residential Open Air School for a period of 12 months.
E.K., Burnt Oak. 28/10/30.	Physically Defective.	Admission to a Residential School. (Varying P.H. and M.S.C., 14/4/39.)
D.F., Edgware. 24/4/32.	Mentally Defective.	Admission to the Special Day School for Educable Mentally Defective Children, Oak Lodge, Finchley, for a trial period of 6 months.
R.C., Colindale. 5/12/25.	Pseudo-hypertrophic Muscular Dystrophy.	Admission to a Residential Home for Incurable Cripple Children.
R.S., N.W. 2. 15/5/29. St. Agnes' School.	Asthma.	Admission to a Residential Open Air School.
J.L., Burnt Oak. 28/7/31. Barnfield School.	Debility.	Period of Convalescent treatment extended 4 weeks.
W.P.B., Burnt Oak. 14/11/33. Meads Infants' School.	Bronchitis following right lower lobar pneumonia.	4 weeks' Convalescent treatment.
R.W., Burnt Oak. 24/5/27. St. James' R.C. School.	General Debility.	4 weeks' Convalescent treatment at a Roman Catholic Home.
L.D., N.W. 2. 27/9/33. Childs Hill School.	General Debility.	3 weeks' Convalescent treatment.
R.D., N.W. 2. 29/11/34.	Debility following Whooping Cough & Bronchitis.	3 weeks' Convalescent treatment.
Mrs. N. & Baby. Burnt Oak.	Debility.	Mother and her Baby to be sent away for a period of 4 weeks' Convalescence.
Mrs. P. & Baby. Burnt Oak.	Anæmia and Debility.	4 weeks' Convalescent treatment.

10.—ANNUAL HOLIDAYS AND POST GRADUATE COURSES FOR MUNICIPAL MIDWIVES:

In order that the above may be arranged, I authorised the Medical Officer of Health to negotiate with the Kilburn & West Hampstead District Nursing Association and the Mill Hill Queen's Nursing Association to provide the necessary relief Midwives.

11.—STAFF:

In view of the fact that 2 members of the clerical staff of the Public Health Department are due to be called up for service in the Militia, I authorised the Medical Officer of Health to engage the necessary temporary assistance as and when required.

12.—PAY ORDERS:

I have examined and approved the following Pay Orders:—

					£	s.	d.
20/23	7,613	12	9
288/291	3,855	18	1

13.—INCREMENTS:

The normal list of staff increments for June has been approved.

14.—REPAYMENT OF HOUSING BOND:

I authorised the repayment of 6 per cent. Housing Bond No. 221 for the sum of £650.

15.—HOUSING:

Allotment of Houses.

Appln No.	Name and Address.	Family.	House Allotted.
6578	New, G., 17, Devonshire Place	M. & W. 2 children	96, Clitterhouse Road.

Transfer of Tenancies.

Appln. No.	Name.	From.	To.
4774	Henoeg, W.	22, Clitterhouse Crescent	57, Claremont Road.
6040	Hale, E.	96, Clitterhouse Road	6, Garth Road.
4209	Erwood, E. W.	139, Claremont Road	70, Clitterhouse Crescent.
5021a	Lewis, T.	80, Clitterhouse Crescent	22, Clitterhouse Crescent.
4815	Marshall, O.	117, Clitterhouse Road	80, Clitterhouse Crescent.
2206	Harrington, A. G.	62, Clitterhouse Road	139, Claremont Road.
5784	Madden, J.	154, Clitterhouse Road	62, Clitterhouse Road.
2675	Moore, E.	7, St. David's Place	117, Clitterhouse Road.

16.—DEDICATION OF LAND AT THE JUNCTION OF BRAMPTON GROVE AND THE BURROUGHS:

I gave authority for payment of reasonable legal costs and Surveyor's fees in connection with the Conveyance of land to the Council by All Souls' College.

17.—SEALING OF DOCUMENTS:

I gave authority for the Corporate Seal to be affixed to the following documents:—

Agreement	Hendon Electric Supply Company Ltd. and the Corporation—as to electrical installation to houses on the Dole Street Estate.
Petition	Against the Colne Valley Water Bill.

18.—REQUISITIONS:

The following requisitions were approved and signed:—

	£	s.	d.
Town Clerk's Department	51	17	6
Borough Surveyor's Department	258	5	7
General Stationery	269	0	9
Public Health Department	14	10	0

HERBERT G. POTTER,

Mayor.

9th June, 1939.

Moved by His Worship the Mayor, seconded by Alderman Copestake, and
284.—RESOLVED—**That the foregoing report be approved and adopted.**

The Meeting terminated at 6.16 p.m.

APPENDIX "A."

SCHEDULE OF TENDERS RECEIVED FOR THE ERECTION OF A PAVILION
AND LAVATORIES IN EDGWAREBURY PARK, EDGWARE.

Contractor.	Amount of Tender.		
	£	s.	d.
R. F. Peachey & Sons Ltd., 5/11, Theobalds Road, W.C. 1	2587	0	0
Buckingham & Sons Ltd., 45, Vivian Avenue, Hendon Central, N.W. 4	2550	0	0
G. H. Kempster Ltd., Beechwood Works, Beechwood Rise, Watford	2180	18	0
H. Pickrill, 8, Station Buildings, Wealdstone	2170	0	0
Garsubil Ltd., 788/790, Finchley Road, Golders Green, N.W. 11	2117	0	0
F. & C. Costin Ltd., 268, Kenton Road, Kenton, Harrow	2046	0	0
A. H. W. Todman & Son Ltd., 284, High Road, Harrow Weald	1999	0	0
E. S. Moss Ltd., 159, Brent Street, N.W. 4	1950	0	0
J. Norman Jones, 4, Southbourne Court, Colindale, N.W. 9	1900	0	0

APPENDIX "B."

SCHEDULE OF TENDERS RECEIVED FOR THE ERECTION OF A BANDSTAND
AND SHELTER IN WATLING PARK, BURNT OAK, EDGWARE.

Contractor.	Amount of Tender.	
	£	s. d.
R. F. Peachey & Sons Ltd., 5/11, Theobalds Road, W.C. 1	945	0 0
Buckingham & Sons Ltd., 45, Vivian Avenue, Hendon Central, N.W. 4	698	0 0
E. S. Moss Ltd., 159, Brent Street, N.W. 4	650	0 0
Garsubil Ltd., 788/790, Finchley Road, Golders Green, N.W. 11	630	0 0
H. Pickrill, 8, Station Buildings, Wealdstone	620	0 0
A. H. W. Todman & Son Ltd., High Road, Harrow Weald	599	0 0
F. & C. Costin, 268, Kenton Road, Kenton, Harrow	484	0 0
G. H. Kempster Ltd., Beechwood Works, Beechwood Rise, Watford	479	3 1

APPENDIX "C."

SCHEDULE OF TENDERS RECEIVED FOR BITUMINOUS MACADAM SURFACING
TO CARRIAGEWAY—SOUTHOVER.

Contractor.	Per square yard.	
	s.	d.
Modern Asphalt Pavements Ltd., Ditton Place, Larkfield, Kent	4	5
The Val de Travers Asphalte Paving Co., Ltd., 21/22, Old Bailey, E.C. 4	4	4
Associated Asphalt Co., Ltd., Thames House, Westminster, S.W. 1	4	3
H. V. Smith & Co., Ltd., 235, Westminster Bridge Road, S.E. 1	4	3
Highways Construction Ltd., Iddesleigh House, Caxton Street, Westminster, S.W. 1	4	2
The Limmer & Trinidad Lake Asphalt Co., Ltd., Steel House, Tothill Street, S.W. 1	4	1
G. Wimpey & Co., Ltd., 27, Hammersmith Grove, W. 6	3	11½
Constable, Hart & Co., Ltd., Broadway Buildings, Broadway, Westminster, S.W. 1	3	11

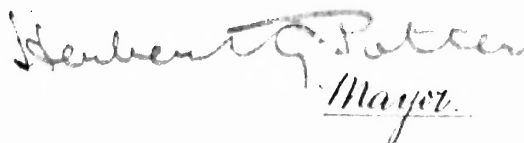
 Herbert G. Patten
 Mayor.

Reports of Committees.

Report (No. 1) of the Education Committee.

23rd May, 1939.

COMMITTEE:

*Alderman J. J. Copestake, J.P. (*Chairman*).

Aldermen:

S. H. Egan, J.P.,
B. Flowers,

*W. M. Maughan, J.P.,

B. J. Monro.

Councillors:

*E. Arter, M.C., M.I.A.E.,
*H. Connell, J.P.,
*A. W. Curton,
*C. H. Hignett,
*P. Lightfoot,

*A. A. Naar, M.B.E.,
(Mrs.) F. E. Parvin,
T. Pugh,
C. R. Richardson,
T. J. Scott,

W. H. N. Shakespeare,
M.C., A.F.C., J.P.,
*H. P. Small,
(Mrs.) M. Thomas.

Co-opted:

*Mrs. S. J. Bannister,
L.L.A.,
*The Rev. N. R. Boyd,
M.A.,

*Major N. G. Brett
James, M.A.,
B.Litt., F.S.A.,

*The Rev. P. C. Howell,
*The Rev. I. Livingstone.

* denotes Member present.

Apologies for absence were submitted on behalf of Aldermen Egan, Flowers and Monro, and Councillors (Mrs.) Parvin, Richardson, Scott and Shakespeare.

MINUTES:

The Minutes of the Meetings held on the 25th April and 2nd May, 1939, were read, confirmed and signed.

CORRESPONDENCE:

The various letters had been referred to the respective Sub-Committees.

REPORT OF PUBLIC HEALTH AND MEDICAL SERVICES COMMITTEE:

RESOLVED—

THAT the following extract from the Report of the above Committee, dated 15th May, 1939, be received:—

REPORT OF SCHOOL MEDICAL OFFICER.

1. STATISTICAL INFORMATION:

Statistics for the four weeks ended on the 6th May, were submitted and are summarised in the appendix to the report of the Finance and General Purposes Committee.

II. DEFECTIVE CHILDREN:

On the report of the School Medical Officer, it was

RESOLVED TO RECOMMEND—That in the undermentioned cases action be taken as follows:—

Case.	Defect.	Recommendation.
K.R., Burnt Oak	Malnutrition, debility and generalised catarrh of the chest	Four weeks' convalescence.
N.P., Burnt Oak	General debility following appendicectomy	Two months' convalescence.
E.K., N.W. 4	Mentally defective (feeble minded)	Admission to the Special Day School for Educable Mentally Defective Children, Oak Lodge, Finchley for a trial period.
K.J., Burnt Oak	General debility	Two months' convalescence.
V.P., Burnt Oak	Asthma and bronchitis	Three months at a South coast Convalescent Home, in two periods of six weeks, with Tonsillectomy in the interval.
V.G., N.W. 9	Chorea and rheumatic carditis	Three months' convalescence at a suitable Heart Home.
M.N., N.W. 2	Bronchial catarrh following bronchitis	One month's convalescence at Holy Cross Convent, Broadstairs.
L.E., Burnt Oak	Deaf	Admission to a Special School for Deaf Children.
D.T., N.W. 9	Mentally defective (feeble minded)	Admission to the Special Day School for Educable Mentally Defective Children, Oak Lodge, Finchley.
J.B., N.W. 9	Spastic paraplegia	Admission to a Day School for Physically Defective Children.

III. REQUISITIONS:

Requisitions amounting to the sum of £42 4s. 6d. were submitted and **approved.**

Moved by Alderman Maughan, seconded by Major Brett James, and **RESOLVED—**

THAT the foregoing extract from the Report of the Public Health and Medical Services Committee be approved and adopted.

SCHOOL MANAGEMENT SUB-COMMITTEE:

RESOLVED—

THAT the following Report be received:—

9th May, 1939.

SUB-COMMITTEE:*Alderman B. Flowers (*Chairman*).

Aldermen: *J. J. Copestake, J.P., *W. M. Maughan, J.P.,
Councillors: E. Arter, M.C., M.I.A.E., *T. Pugh, T. J. Scott,
 *P. Lightfoot, *C. R. Richardson, (Mrs.) M. Thomas,
 *A. A. Naar, M.B.E.,
Co-opted: *Major N. G. Brett The Rev. P. G. Howell,
 James, M.A.,
 B.Litt., F.S.A.,

* denotes Member present.

Apologies for absence were submitted on behalf of Councillor T. J. Scott and the Rev. P. G. Howell.

1.—H.M. INSPECTOR'S REPORTS:

RESOLVED TO RECOMMEND—

- (a) **THAT the Reports of H.M. Inspector on the following schools be noted with satisfaction:—**

School.	Inspected on:—
Edgware Junior Mixed and Infants'	19th April, 1939.
The Meads Infants'	20th February and 4th April, 1939.
Orange Hill Central Girls'	8th and 9th March, 1939.
Sunnyfields Infants'	27th March and 4th April, 1939.
Wessex Gardens Infants'	10th March, 1939.

- (b) **THAT the Head Teachers of the Algernon Road Junior Mixed and the Orange Hill Central Boys' Schools be asked for their observations on H.M. Inspector's recent Reports on their respective schools.**

2.—AMALGAMATION OF JUNIOR AND INFANT DEPARTMENTS:

In pursuance of the Committee's instructions, the Director of Education submitted a report hereon.

RESOLVED TO RECOMMEND—

- (a) **THAT the report be noted.**
 (b) **THAT where, in combined Infant and Junior Schools, an Assistant Teacher occupies a post of special responsibility in connection with the teaching of Infant or Junior Children, a special salary allowance of two additional increments be paid to him or her under Section 14 of the Burnham Elementary Report 1938, with effect from 1st April, 1939.**

3.—COMMUNITY CENTRES:

- (a) **CLITTERHOUSE ESTATE:**

A letter was submitted from the Middlesex Local Education Authority asking whether the Authority would consider the possibility of placing a site at the disposal of the County Council as a contribution towards a Community Centre for the Clitterhouse area on the understanding that the County Council provide the building in its capacity of Higher Education Authority. In this connection the Director of Education reported that the question of availability of a suitable site had been referred to the Estates, Parks and Allotments Committee of the Council prior to an application being made to the Minister of Health. **Noted.**

(b) WATLING ASSOCIATION:

A letter was submitted from the Middlesex Local Education Authority giving details of the estimated cost of £19,082 for the proposed extension of the Watling Centre, together with information with regard to a suggested modification of the original plans thereof. A letter was also submitted from the Watling Association asking the Committee to receive a deputation from the Association on this matter if considered desirable.

RESOLVED TO RECOMMEND—

THAT further consideration be adjourned until such time as the revised plans are available for inspection.

4.—ALL SAINTS' C.E. SCHOOL:

A letter was submitted from the Board of Education forwarding a copy of a letter received from the Managers and requesting that the Board be furnished with the observations of the Authority on the suggestion that the All Saints' C.E. School should be closed. The Board also desire to be informed as to the schools to which the children at present attending the school could be transferred with the present number on books in each case.

RESOLVED TO RECOMMEND—

THAT the Board of Education be informed that the Authority are in agreement with the proposals of the Managers to close the All Saints' C.E. School.

Arising out of the above, it was further RESOLVED TO RECOMMEND—

THAT the Borough Surveyor be instructed to expedite the preparation of plans for the two new senior schools on the Hendon Way site.

5.—REFUND OF EXAMINATION FEES:

A list was submitted of children of the St. Mary's C.E. Senior School who have been successful in passing recent Pitman's Shorthand Examinations.

RESOLVED TO RECOMMEND—

THAT the entry fees amounting to 16/- be refunded.

6.—DOLE STREET JUNIOR AND INFANTS' SCHOOL:

It was reported that the new Dole Street Council Junior and Infants' School opened on 1st May, 1939, and that the number of children on roll was 300. **Noted.**

7.—REQUISITIONS:

Requisition Sheets Nos. 294/6 amounting to £1,513 18s. 4d. were submitted and **Noted.**

Moved by Alderman Maughan, seconded by Major Brett James, and RESOLVED—

THAT the Report of the School Management Sub-Committee be approved and adopted.

WORKS SUB-COMMITTEE:

RESOLVED—

THAT the following Report be received:—

9th May, 1939.

SUB-COMMITTEE:

*Councillor W. H. N. Shakespears, M.C., A.F.C., J.P. (Chairman).

Aldermen:	S. H. Egan, J.P.,	*B. J. Monro,	
Councillors:	H. Connell, J.P.,	*C. H. Hignett,	
	*A. W. Curton,	*(Mrs.) F. E. Parvin,	H. P. Small.
Co-opted:	* (Mrs.) S. J. Bannister, L.L.A.,	*The Rev. N. R. Boyd, M.A.,	The Rev. I. Livingstone.

* denotes Member present.

Apologies for absence were submitted on behalf of Alderman Egan and the Rev. I. Livingstone.

1.—DOLE STREET COUNCIL JUNIOR AND INFANTS' SCHOOL:

It was reported that the school buildings were now finished with the exception of a few minor items. Completion of the fencing is proceeding. **Noted.**

2.—BROADFIELDS AVENUE JUNIOR AND INFANTS' SCHOOL:

(a) SCHOOL BUILDINGS:

A communication was submitted from the Board of Education stating that the Board regard the arrangements shown on the plans as satisfactory for the accommodation of 440 junior and infant children (including a Nursery class of 40). Before giving formal approval the Board require further information regarding the site and Quantity Surveyor's fees. The Board also state that the estimated cost of the Caretaker's Bungalow is higher than they are prepared to approve and they ask the Authority to effect substantial reductions thereon.

It was reported that the cost of the Bungalow had been reduced by £100 and that the information regarding the site and Quantity Surveyor's fees had been forwarded to the Board. **Noted and approved.**

(b) SITE:

A communication was submitted from Messrs John Laing & Son Ltd. withdrawing their objections to the Corporation taking possession of this site.

RESOLVED TO RECOMMEND—

THAT the Town Clerk, on behalf of the Corporation, be instructed to serve the necessary notice of entry as soon as possible.

3.—SCHOOL SITE AT THE FAIRWAY, MILL HILL:

It will be remembered that the Corporation purchased, under their general powers, about 13½ acres of land fronting The Fairway, Mill Hill. The Borough Surveyor submitted plans showing the seven acres required for an elementary school and suggested that the Corporation be recommended to apply to the Board of Education for the appropriation of this land for educational purposes. It will be necessary to agree with the District Valuer the figure at which the appropriation is to take place.

RESOLVED TO RECOMMEND—

THAT the site plans be approved and that all necessary steps be taken for obtaining the sanctions required.

4.—HYDE COUNCIL SCHOOL:

(a) HYDE CRESCENT GATE:

The Borough Surveyor reported on a request to fix barbed wire over the entrance gate in Hyde Crescent.

RESOLVED TO RECOMMEND—

THAT no action be taken in the matter.

(b) WIRE NETTING:

RESOLVED TO RECOMMEND—

THAT the question of replacing the existing wire netting over the boundary fence by chain link fencing be adjourned for the present.

5.—GARDEN SUBURB SCHOOL:

RESOLVED TO RECOMMEND—

THAT the Borough Surveyor be authorised to replace the vertical hot water supply boiler at this school at an estimated cost of £14.

[Having considered the matter in its financial bearing, the Finance and General Purposes Committee concur in the proposal.]

6.—DEANSBROOK INFANTS' SCHOOL:

RESOLVED TO RECOMMEND—

THAT the external decorations at this school be postponed for one year and that the Borough Surveyor be authorised to arrange for the steel sashes to the windows to receive one coat of paint in order to preserve them at an estimated cost of £20.

[Having considered the matter in its financial bearing, the Finance and General Purposes Committee concur in the proposal.]

7.—BRENT MODERN SCHOOL—HEATING PLANT:

RESOLVED TO RECOMMEND—

THAT the Borough Surveyor be authorised to make arrangements for the alterations mentioned to the heating plant at this school at an estimated cost of £25.

[Having considered the matter in its financial bearing, the Finance and General Purposes Committee concur in the proposal.]

8.—CHILDS HILL COUNCIL SCHOOL:

It was reported that the tiles to the roof of the shelter mentioned have laminated very badly and that such roof is generally in a bad condition.

RESOLVED TO RECOMMEND—

THAT the Borough Surveyor be authorised to arrange for this roof to be stripped and re-tiled at an estimated cost of £45.

[Having considered the matter in its financial bearing, the Finance and General Purposes Committee concur in the proposal.]

9.—FRITH MANOR JUNIOR AND INFANT SCHOOL—ENTRANCE STEPS:

Pursuant to Item 2 (c) in the Report of this Sub-Committee, dated 28/3/39, a letter was read from the Headmaster regarding the entrance steps of this school. It was directed that a copy of the Headmaster's letter be entered in MS. in the Sub-Committee's Minute Book and that a communication be forwarded to the Woodside Park Garden Suburb Ratepayers' Association on the lines mentioned.

10.—GOLDBEATERS COUNCIL SCHOOL:

A communication was submitted from Mr. E. Sewell Harris, on behalf of the Goldbeaters Parent-Teacher Group, urging the Committee to provide adequate Air Raid Shelters at Goldbeaters School and to improve the exits from that school, particularly with regard to the Infants' Department, and also asking whether it would be possible

to replace the existing drinking fountains by up-to-date types of fountain. Consideration of this communication was adjourned pending the inspection of the premises by Councillor Shakespeare and the Borough Engineer.

11.—DOLE STREET JUNIOR AND INFANT SCHOOL:

A communication was submitted from Mr. F. H. Blackburn asking that steps be taken to ensure that there is a minimum of risk to children journeying between the above-named school and the Devonshire Road side of Sanders Lane.

RESOLVED TO RECOMMEND—

THAT this communication be referred to the Highways Committee.

12.—ST. VINCENT'S R.C. SCHOOL AND ORPHANAGE:

A communication was submitted from the Board of Education approving the work shown on the plans for alterations and additions at St. Vincent's R.C. School and Orphanage, subject to the observations mentioned.

It was reported that a copy of this letter and the plans in question had been forwarded to the Managers for attention. **Noted.**

13.—REQUISITIONS:

Requisition Sheet No. 272 amounting to £328 19s. 1d. was submitted and **approved.**

Moved by Alderman Maughan, seconded by Major Brett James, and **RESOLVED—**

THAT the Report of the Works Sub-Committee be approved and adopted.

STAFFS AND SALARIES SUB-COMMITTEE:

RESOLVED—

THAT the following Report be received:—

9th May, 1939.

SUB-COMMITTEE:

Councillor E. Arter, M.C., M.I.A.E. (Chairman).

Aldermen:	*J. J. Copestake, J.P., (Presiding),	*B. Flowers,	*W. M. Maughan, J.P.
Councillors:	*P. Lightfoot, *A. A. Naar, M.B.E.,	*T. Pugh, *C. R. Richardson,	T. J. Scott, (Mrs.) M. Thomas.
Co-opted:	*Major N. C. Brett James, M.A., B.Litt, F.S.A.,	The Rev. P. C. Howell.	

* denotes Member present.

Apologies for absence were submitted on behalf of Councillor T. J. Scott and the Rev. P. G. Howell.

1.—APPOINTMENTS FROM TRAINING COLLEGES, 1939:

It was reported that, in accordance with authority delegated, Councillor E. Arter and the Director of Education had interviewed certain students who were leaving Training College this year and had **RESOLVED—**

THAT the undermentioned students be appointed Certificated Assistant Teachers on the Committee's Staff as from 29th August, 1939, in full-time service exclusively in the capacity of teachers in accordance with the conditions of employment under Article 17 of the Code, and subject to the conditions of appointment of the Committee in force from time to time and upon the terms and subject to the conditions of the Burnham Arbitration Award and the decisions of the Board of Education relating thereto, or upon the terms and subject to the conditions of any other scale of salaries that may be adopted by the Committee, the engagements to be determinable on either side by a notice of one calendar month:—

Bishop Otter College:—

Evans, Margaret I. B.

Gipsy Hill College:—

Russell, Janet M.

Whitelands College:—

Collier, Gladys M.

James, Margaret F. H.

Knight, Margaret C.

Parkinson, Joyce M.

Noted.

2.—APPOINTMENT OF STUDENT TEACHER:

An application for appointment as Student Teacher for the year 1939/40 was submitted from Miss Jean M. Metcalfe.

RESOLVED TO RECOMMEND—

THAT, subject to the submission of a satisfactory Medical Certificate, Miss Jean M. Metcalfe be appointed Student Teacher for the period 1st September, 1939, to 31st August, 1940, with salary at the rate of £40 per annum.

3.—GRADING OF SCHOOLS, 1939/40:

The Director of Education submitted a report showing the Grading of the Committee's Schools for the year 1939/40 determined in accordance with Section 8 of the Burnham Elementary Report, 1938.

RESOLVED TO RECOMMEND—

THAT the report be approved and adopted and that the salaries of Head Teachers for the financial year 1939/40 be paid in accordance with the following schedule:—

School.	Average Attendance for 3 years ended 31/3/39.	Grade, 1939/40.			Grade payable from 1st April, 1939.
		Provisional only	Substantive.	Protected.	
Algernon Road Junior	279	—	3	3	3
Algernon Road Infants'	271	—	3	3	3
All Saints' C.E.	200	—	2	3	3
Annunciation R.C.	277	—	3	3	3
Barnfield Senior Boys'	333	—	3	3	3
Barnfield Junior Mixed	279	—	3	4	4
Barnfield Infants'	298	—	3	4	4
Bell Lane Mixed	226	—	3	3	3
Bell Lane Infants'	134	—	2	2	2
Brent Modern	209	—	3	5	5
Broadfields Avenue	—	1	—	—	1
Burnt Oak	231	—	3	3	3
Childs Hill Mixed	419	—	4	4	4
Childs Hill Infants'	290	—	3	3	3
Clitterhouse	387	—	4	4	4
Colindale	476	—	4	4	4
Deansbrook Junior Mixed	284	—	3	3	3
Deansbrook Infants'	330	—	3	3	3
Edgware Senior Mixed	—	3	—	4	4
Edgware Junior and Infants'	—	4	—	—	4
Frith Manor	—	3	—	—	3
Garden Suburb Mixed	319	—	3	3	3
Garden Suburb Infants'	199	—	2	2	2
Goldbeaters Senior Mixed	334	—	3	4	4
Goldbeaters Junior Mixed	362	—	4	4	4
Goldbeaters Infants'	328	—	3	3	3
Hyde Junior and Senior Mixed	—	5	—	—	5
Hyde Infants'	—	3	—	—	3
Meads Junior Mixed	266	—	3	3	3
Meads Infants'	239	—	3	3	3
Orange Hill Central Boys'	323	—	3	3	3
Orange Hill Central Girls'	351	—	4	4	4
St. Agnes' R.C.	230	—	3	3	3
St. James' R.C.	324	—	3	3	3
St. John's C.E.	123	—	2	2	2
St. Mary's C.E. Senior	224	—	3	3	3
St. Mary's C.E. Junior	255	—	3	3	3
St. Mary's R.C.	123	—	2	2	2
St. Paul's C.E.	143	—	2	3	3
St. Vincent's R.C.	148	—	2	2	2
Sunnyfields Infants'	264	—	3	3	3
Sunnyfields Infants'	251	—	3	3	3
Wessex Gardens Boys'	271	—	3	3	3
Wessex Gardens Girls'	265	—	3	3	3
Wessex Gardens Infants'	311	—	3	3	3
Woodcroft Senior Girls'	395	—	4	4	4
Woodcroft Junior Mixed	339	—	3	4	4
Woodcroft Infants'	—	—	—	—	—

4.—INTERCHANGE OF TEACHERS:

(a) LEAGUE OF THE EMPIRE:

It was reported that a letter had been received from the League of the Empire forwarding the application form of Miss Clementine M. Cruickshank of British Columbia whom it is desired to exchange for Miss Dorothy Jones of the Brent Modern School.

RESOLVED TO RECOMMEND—

THAT the proposed exchange be approved.

(b) ASSOCIATION OF EDUCATION COMMITTEES:

A letter was submitted from the Association of Education Committees with regard to a proposed scheme for the interchange of teachers between schools in England and Wales and enquiring whether this Committee would be prepared to adopt the scheme.

RESOLVED TO RECOMMEND—

THAT the Association of Education Committees be informed that this Committee are prepared to participate in such a scheme.

5.—NATIONAL SERVICE:

A letter was submitted from Miss Margaret Thompson, Certificated Assistant Mistress on the staff of the Woodcroft Infants' School stating that, in a National Emergency, she would, as a member of the Nursing Auxiliary of the British Red Cross Society, be required to do full time mobile work, and enquiring whether the Committee would agree to this and whether her post would be kept open for her.

RESOLVED TO RECOMMEND—

THAT further consideration of this matter be adjourned.

6.—SUMMER VACATION COURSES:

RESOLVED TO RECOMMEND—

THAT special leave of absence, with salary, be granted as follows to enable the teachers concerned to attend the vacation courses described:—

Teacher.	Vacation Course.	Period of leave of absence, with salary.
Penna, B.Sc., Reginald F., Orange Hill School	"The Junior School" at Derby Training College	17th to 28th July, 1939.
Green, Muriel, Dole Street School	Board of Education Course in Dressmaking at Kilburn Polytechnic	24th to 28th July, 1939.

7.—RESIGNATIONS:

RESOLVED TO RECOMMEND—

THAT the undermentioned resignations be accepted:—

Teacher.	School.	Date of Leaving.
Clark, Dora M.	Orange Hill Central Girls'	28th August, 1939.
Clifford, Evelyn K.	Colindale	31st May, 1939.
Hayden, Mary A.	St. Vincent's R.C.	31st May, 1939.
Reid, Elsie	Woodcroft Senior (Girls'	30th June, 1939.

8.—ABSENCES OF TEACHERS, ETC.:

(a) GENERAL LIST:

A Statement with regard to the absences of 66 teachers, etc., was submitted and **noted**.

(b) SPECIAL CASE:

RESOLVED TO RECOMMEND—

THAT the School Medical Officer be instructed to submit a report concerning the recent absence of Mrs. G. Harrop, Barnfield Junior Mixed School, and that, in the meantime, further payment of salary be suspended.

AMENDMENT:

Moved by Alderman Copestake, duly seconded, and RESOLVED—

THAT Item 8 (b) be dealt with in Committee.

9.—ASSISTANT MISTRESS—FAILURE TO TAKE UP APPOINTMENT:

The Director of Education reported the circumstances in which Miss Agnes M. Neill, B.A., had failed to take up her appointment as Certificated Assistant Mistress on the staff of the Dole Street Council School when it opened on 1st May.

RESOLVED TO RECOMMEND—

THAT, in view of the information given, this appointment be allowed to lapse.

Moved by Alderman Maughan, seconded by Major Brett James, and RESOLVED—

THAT the Report (as amended) of the Staffs and Salaries Sub-Committee be approved and adopted.

SCHOOL ATTENDANCE SUB-COMMITTEE:

RESOLVED—

THAT the following Report be received:—

9th May, 1939.

SUB-COMMITTEE:

***Councillor C. H. Mignett (Chairman).**

<i>Aldermen:</i>	S. H. Egan, J.P.,	*B. J. Monro.	
<i>Councillors:</i>	H. Connell, J.P.,	*(Mrs.) F. E. Parvin,	*W. H. N. Shakespeare,
	*A. W. Curton,	H. P. Small.	M.C., A.F.C., J.P.
<i>Co-opted:</i>	*(Mrs.) S. J. Bannister,	*The Rev. N. R. Boyd,	The Rev. I. Livingstone.
	L.L.A.,	M.A.,	

** denotes Member present.*

Apologies for absence were submitted on behalf of Alderman Egan, J.P., and the Rev. I. Livingstone.

1.—JUVENILE COURT PROCEEDINGS:

Particulars of cases dealt with during the period 24th March, 1939, to 4th May, 1939, were submitted as follows:—

Charges and Summonses: Young People 14, Children 15, Total 29.

Offence.	Sex and age of Child or Young Person.	Action taken.
At Wealdstone:—		
Breaking and entering	Boy, 16 years	To Borstal, 2 years.
Beyond Control	Girl, 16½ years	Supervision Order.
Larceny (Turf)	Boy, 16 years	Dismissed P.O. Act, Costs 10/-.
Larceny (Turf)	Boy, 14½ years	Dismissed P.O. Act, Costs 10/-.
Larceny	Boy, 13½ years	Dismissed P.O. Act.
Larceny	Boy, 13 years	Dismissed P.O. Act.
Larceny (Ammunition)	Boy, 13 years	Dismissed P.O. Act.
Larceny (Ammunition)	Boy, 12 years	Dismissed P.O. Act.
Larceny (Ammunition)	Boy, 13½ years	Dismissed P.O. Act.
Larceny (Ammunition)	Boy, 13½ years	Dismissed P.O. Act.
Larceny (Ammunition)	Boy, 12½ years	Dismissed P.O. Act.
Larceny (Ammunition)	Boy, 13 years	Probation 1 year.
Larceny (Ammunition)	Boy, 10½ years	Dismissed P.O. Act.
Larceny	Boy, 12 years	Dismissed P.O. Act.
Larceny	Boy, 11½ years	Probation 1 year.
Taking away motor car, etc.	Boy, 15 years	Fined 20/-.
Larceny	Boy, 13¾ years	Probation 1 year.
Larceny	Boy, 13¾ years	Probation 1 year.
Larceny	Boy, 12 years	Dismissed P.O. Act.
Larceny	Boy, 10½ years	Dismissed P.O. Act.
Malicious damage	Boy, 16 years	Dismissed P.O. Act.
Malicious damage	Boy, 14½ years	Dismissed P.O. Act.
Malicious damage	Boy, 14½ years	Dismissed P.O. Act.
Failing to conform (traffic lights)	Boy, 16 years	Fined 10/-.
Attempted larceny	Boy, 16½ years	Dismissed P.O. Act.
No front light (cycle)	Boy, 16¾ years	Dismissed P.O. Act.
Larceny	Girl, 16½ years	Adjourned to 17/5/39.
Taking Motor Car	Boy, 17 years	Dismissed P.O. Act, Costs 20/-.
At Willesden:—		
Forgery	Boy, 15½ years	Dismissed P.O. Act.

Noted.

2.—SCHOOL ATTENDANCE:

Statistics of Attendance were submitted as follows:—

(a) Percentages:—

Week ended 24th March, 1939	88.1
Week ended 31st March, 1939	88.5
Week ended 5th April, 1939	82.3
Week ended 21st April, 1939	92.4

(b) Statistics for the week ended 28th April, 1939:—

	Education.
Number on Roll	14,371
Average Attendance	13,325
Percentage of Attendance	92.7

Noted.

3.—EMPLOYMENT OF CHILDREN:

The report of the Employment Officer for the period 23rd March, 1939, to 3rd May, 1939, was submitted as follows:—

	Boys.	Girls.
Employment Cards and Badges Issued	28	1
Employment Badges Returned	33	1
New Permits granted:—		
Delivery of Newspapers	18	1
Delivery (Shops)	9	—
Delivery of Milk	2	—
Medically examined (Certificates granted)	14	—
Number of children employed at date	276	10
Employment in Entertainments—Licences granted	—	1

Noted.

Moved by Alderman Maughan, seconded by Mrs. Bannister, and RESOLVED—

THAT the Report of the School Attendance Sub-Committee be approved and adopted.

FINANCE AND GENERAL PURPOSES SUB-COMMITTEE:

RESOLVED—

THAT the following Report be received:—

9th May, 1939.

SUB-COMMITTEE:

*Councillor A. W. Curton (*Chairman*).

Aldermen:	*J. J. Copestake, J.P., S. H. Egan, J.P.,	*B. Flowers,	B. J. Monro.
Councillors:	*E. Arter, M.C., M.I.A.E., *C. H. Hignett, *T. Pugh,	*C. R. Richardson, *W. H. N. Shakespeare, M.C., A.F.C., J.P.,	(Mrs.) M. Thomas.

* denotes Member present.

An apology for absence was submitted on behalf of Alderman Egan.

1.—ACCOUNTS FOR PAYMENT, PAY ORDERS AND CHEQUES:

It was reported that the accounts included in lists Nos. 280/281 amounting in the aggregate to £681 17s. 0d., had been examined by Councillor Richardson in pursuance of Standing Orders and Resolutions of the Council.

RESOLVED TO RECOMMEND—

THAT the accounts be approved and that the necessary pay orders be prepared and submitted for signature in accordance with Section 187 of the Local Government Act, 1933.

2.—MILK IN SCHOOLS SCHEME, MIDSUMMER HOLIDAYS, 1939:

Consideration was given to the following reference from the Public Health and Medical Services Committee regarding the proposal for the supply of milk to elementary school children during the Midsummer Holidays, viz. :—

“ That the Education Committee be asked to reconsider the matter in relation to the question of organisation.”

The Director of Education submitted replies from various Voluntary Organisations who had been invited to assist in carrying out the scheme and pointed out certain fundamental difficulties which had been raised by one of the Organisations.

After discussion the Sub-Committee are reluctantly of opinion that the establishment of a scheme for the issue of milk to elementary school children at selected centres during the Midsummer Holidays is not a practicable proposition, and accordingly

RECOMMEND—

- (a) **THAT no further action be taken in the matter.**
 (b) **THAT any previous Minute inconsistent herewith be rescinded.**

3.—HENDON SCHOOLS' SPORTS ASSOCIATION:

The Balance Sheet of the Association for the year ended 31st March, 1939 (a copy of which had been duly circulated to each Member of the Committee) was submitted. The Association ask the Education Committee to consider the question of granting financial aid as in previous years.

RESOLVED TO RECOMMEND—

THAT a grant of £100 be made to the Hendon Schools' Sports Association in respect of the current financial year and that the Board of Education be asked to give their approval thereto.

[Having considered the matter in its financial bearing, the Finance and General Purposes Committee concur in the proposal.]

4.—NATIONAL SOCIETY FOR THE PREVENTION OF CRUELTY TO CHILDREN:

A communication was submitted from this Society appealing for financial assistance in respect of work undertaken in conjunction with Officers of the Authority.

RESOLVED TO RECOMMEND—

THAT a donation of £5 5s. 0d. be made to the above-named Society in respect of services rendered during the past year.

5.—EDGWARE SENIOR SCHOOL—PROPOSED SCHOOL JOURNEY:

Consideration was given to an application from the Headmaster for a grant of £15 under the School Journeys Scheme in respect of a proposed educational journey to the Isle of Wight by pupils attending this school, during the period 7th to 14th July, 1939.

RESOLVED TO RECOMMEND—

THAT the application be granted.

[Having considered the matter in its financial bearing, the Finance and General Purposes Committee concur in the proposal.]

6.—EMERGENCY SUPPLIES OF FUEL FOR SCHOOLS:

The Director of Education was instructed to arrange forthwith for all cellars in the Hendon Elementary Schools to be stocked to capacity with fuel.

7.—AIR RAID PRECAUTIONS IN SCHOOLS:

RESOLVED TO RECOMMEND—

THAT each Elementary School Department in Hondon be supplied with a first aid box, as per details submitted, at a total estimated cost of £40.

[Having considered the matter in its financial bearing, the Finance and General Purposes Committee concur in the proposal.]

8.—ALGERNON ROAD COUNCIL SCHOOL—EVENING SCHOOL LETTINGS:

The Sub-Committee considered an application from the Caretaker of this school for arrears of overtime allowance. The Director of Education reported thereon.

RESOLVED TO RECOMMEND—

THAT the application be not granted.

9.—USE OF SCHOOLS FOR TERRITORIAL ARMY TRAINING:

Board of Education Administrative Memorandum No. 192 was submitted, pointing out that, owing to the expansion of the Territorial Army and the large increase in accommodation which will be required, permission to hire school premises will in all probability be asked for by local Territorial Army Associations. The Board hope that, wherever possible, such requests will be granted. **Noted.**

10.—ST. JAMES' R.C. CENTRAL SCHOOL—CINEMA PROJECTOR:

It was reported that the Board had sanctioned an expenditure of £60 by the Authority towards the cost of providing a 16 mm. sound cinema projector for the above-named school. **Noted.**

11.—EDUCATION ACT, 1936—EXEMPTIONS FOR BENEFICIAL EMPLOYMENT:

Consideration was given to a recommendation by the Juvenile Employment Sub-Committee to the effect that the Education Committee be asked to appoint that Sub-Committee to be responsible for the administration of the beneficial employment clauses of the Education Act, 1936.

RESOLVED TO RECOMMEND—

THAT the Education Committee appoint a Special Sub-Committee to deal with applications for exemption on the grounds of beneficial employment under the Education Act, 1936, such Sub-Committee to comprise 8 members, 6 of whom shall be members of the Education Committee and 2 of whom shall be members of the Juvenile Employment Sub-Committee.

12.—ADMINISTRATIVE STAFF:

RESOLVED TO RECOMMEND—

THAT authority be given for the appointment of a Junior Male Assistant to the Administrative Staff of the Education Committee, with salary in accordance with the Council's scale.

[The Finance and General Purposes Committee concur in the proposed appointment.]

13.—CONVALESCENT TREATMENT—L.M.S. RAILWAY HOSPITAL FUND:

The Borough Treasurer reported on a communication received from the L.M.S. Railway Hospital Fund offering to make payments in respect of parents' contributions for maintenance of children undergoing short term convalescent treatment, subject to the production of the Hospital Fund vouchers. The value of such vouchers is 5/- per week for a maximum period of four weeks.

RESOLVED TO RECOMMEND—

THAT the offer of the L.M.S. Railway Hospital Fund be accepted.

[Having considered the matter in its financial bearing, the Finance and General Purposes Committee concur in the proposal.]

14.—WORKS SUB-COMMITTEE MATTERS:

The following items, which had been sanctioned by the Works Sub-Committee, were submitted and **approved**:—

Garden Suburb School:—

Replace vertical hot water supply boiler £14

Deansbrook Infants' School:—

Paint steel sashes to windows £20

Brent Modern School:—

Alterations to heating plant £25

Childs Hill School:—

Strip and re-tile roof of shelter..... £45

15.—REQUISITIONS:

Requisitions which had been sanctioned by the School Management Sub-Committee (£1,513 18s. 4d.) and the Works Sub-Committee (£328 19s. 1d.) were submitted and **approved**.

16.—OTHER BUSINESS:

The Director of Education was instructed to communicate with the Correspondents of St. Paul's C.E. and St. Vincent's R.C. Schools regarding meetings of Managers.

Moved by Alderman Maughan, seconded by Councillor Arter, and **RESOLVED**—

THAT the Report of the Finance and General Purposes Sub-Committee be approved and adopted.

JUVENILE EMPLOYMENT SUB-COMMITTEE:

RESOLVED—

THAT the following Report be received:—

2nd May, 1939.

SUB-COMMITTEE:

***Councillor P. Lightfoot** (*Chairman*).

Alderman: ***J. J. Copestake, J.P.**

Councillors: **H. Connell, J.P.,**

***(Mrs.) F. E. Parvin,**
***G. R. Richardson,**

(Mrs.) M. Thomas

Other Representatives: **Mr. J. G. Barr, B.A.,**
***Mr. S. A. Crassam,**
***Mr. E. Van Celder,**
Mr. J. Donaldson,
***Mr. T. P. Lardner,**
Mr. E. W. Stennett,
***Miss I. M. Hornsby,**

Miss E. M. Slocombe,
Mr. W. F. Smithers,
Mr. P. Yates,
Mr. A. Daniels,
***Miss F. M. Levett,**
Mr. J. P. Loughlin,
M.B.E.,

***Miss D. P. Dangerfield,**
Mr. A. H. Salt,
Mr. G. J. Crawford,
***Mr. J. Price,**
***Miss S. E. Wilson, B.A.**

** denotes Member present.*

(Miss G. M. Croke, Manager, Employment Exchange, N.W. 9, was also present.)

Apologies for absence were tendered on behalf of Councillor H. Connell, J.P., Miss E. M. Slocombe, Mr. A. Daniels, Mr. A. H. Salt and Mr. E. W. Stennett.

1.—SCHEDULE OF PLACINGS, ETC.:

The following Schedule of Placings, etc., for the 10 weeks ended 24th April, 1939, was submitted and noted:—

REGISTRATIONS:				Boys.	Girls.	Total.
Live Register brought forward	---	---	---	49	37	86
Fresh Registrations	---	---	---	181	108	349
Re-registrations	---	---	---	49	60	109
TOTALS	---	---	---	279	265	544
Placed locally	---	---	---	114	87	201
Placed in other districts	---	---	---	59	45	104
Cancelled or found work other than by Bureau	---	---	---	44	75	119
Live Register carried forward	---	---	---	62	58	120
TOTALS	---	---	---	279	265	544
VACANCIES:						
Brought forward	---	---	---	36	39	75
Notified during period	---	---	---	179	175	354
TOTALS	---	---	---	215	214	429
Filled by local applicants	---	---	---	114	87	201
Filled by applicants from other districts	---	---	---	4	16	20
Filled other than by Bureau or cancelled	---	---	---	63	60	123
Vacancies carried forward	---	---	---	34	51	85
TOTALS	---	---	---	215	214	429
First situations since leaving school	---	---	---	47	58	105
TOTAL VACANCIES FILLED DURING PERIOD:						
By local applicants placed locally	---	---	---	114	87	201
By applicants placed in other districts	---	---	---	59	45	104
By applicants from other districts placed locally	---	---	---	4	16	20
TOTALS	---	---	---	177	148	325
CLAIMS:						
Current at commencement of period	---	---	---	23	13	36
Fresh claims during period	---	---	---	29	26	55
Repeat Claims during period	---	---	---	38	18	56
Claims lapsed during period	---	---	---	70	45	115
Claims current at end of period	---	---	---	20	12	32

Amount of U.I. Benefit and Assistance Paid: £89 6s. 2d.

ANALYSIS OF PLACINGS.

BOYS.		GIRLS.	
Chauffeur (Learner)	2	Canteen Work	1
Drawing Office	1	Cashier	3
Electrician's Mate	2	Domestic Work	5
Engineering:—		Dressmaking	10
General	40	Factory (General)	52
Electrical	5	Hairdressing	—
Motor	1	Laundry Work	—
	46	Office Work	38
Factory (General)	48	Power Machinist	1
Garage Work	3	Shop Assistant	24
Gardener's Assistant	1	Shorthand-Typist	5
Glazier (Learner)	1	Showroom Work	5
Groundsman's Assistant	2	Upholstery	1
Hairdressing	1		
Messenger (G.P.O.)	2		
Messenger (Rly. Co.)	7		
Office Work	21		
Order Boy	1		
Page Boy	2		
Painter's Mate	2		
Pharm. Chemist's Apprentice.....	1		
Plumber's Mate	4		
Salesman (Learner)	1		
Sheet Metal Work	2		
Shop Assistant	6		
Steward's Assistant	3		
Stores Work	7		
Tiler's Mate	1		
Van Boy	3		
Warehouse Work	5		
Woodwork	2		
Total	177	Total	148

Particulars of Vacancies as at 1st May, 1939, were also submitted and **noted**. (A copy of the list is in MS. in the Sub-Committee's Minute Book.)

RESOLVED TO RECOMMEND—

THAT in future a confidential list be issued to the members of this Sub-Committee showing particulars of the juveniles placed by the bureau, and containing information as to the occupations, commencing wages and names of the employers concerned.

AMENDMENT:

Moved by Councillor Small, seconded by Councillor Arter, and **RESOLVED**—

THAT the above recommendation be referred back for further consideration.

2.—SCHEDULE OF LEAVERS AND LIVE REGISTER:

A Schedule showing the number of juveniles on the Live Register at each of the 10 weeks ended 24th April, 1939, and the number of children who were eligible to leave school on 5th April, 1939, was submitted and **noted**. (A copy of the Schedule is in MS. in the Sub-Committee's Minute Book.)

3.—LONDON REGIONAL ADVISORY COUNCIL FOR JUVENILE EMPLOYMENT:

The Fourth Annual Report of the London Regional Advisory Council for Juvenile Employment containing information as to the work of the Council in connection with the following matters was submitted and **noted**:—

- (a) Recent Legislation affecting juveniles.
- (b) The Education Act, 1936.
- (c) The Guide to Employment for Boys and Girls in Greater London.
- (d) The Transference of Juveniles.
- (e) Authorised Courses of Instruction.
- (f) Circulation of Statistics.
- (g) Survey of the Juvenile Employment position during 1938.

4.—EDUCATION ACT, 1936:

A letter was submitted from the London Regional Advisory Council for Juvenile Employment enclosing a copy of the communication in connection with the proposed formation of a Joint Standing Committee for consultation on appropriate matters arising from the Education Act, 1936, the receipt of which was reported at the last meeting.

RESOLVED TO RECOMMEND—

THAT the London Regional Advisory Council for Juvenile Employment be informed that this Sub-Committee support the proposal.

5.—FILMS FOR VOCATIONAL GUIDANCE:

It was reported that pursuant to Minute 6 of the Meeting held on 29th November, 1938, the Local Member of Parliament had been informed of the action which had been taken to secure the recognition of expenditure by the Ministry of Labour on the production of films for vocational guidance purposes, and that he had been asked to bring the matter to the notice of the Minister of Labour.

It was further reported that the Local Member of Parliament had been in communication with the Minister from whom a reply had been received indicating that for various reasons he is not satisfied that the expenditure necessary for the production of vocational guidance films would be justified.

RESOLVED TO RECOMMEND—

THAT a copy of the letter from the Minister of Labour be forwarded to the National Association of Juvenile Employment and Welfare Officers for information.

6.—NATIONAL ASSOCIATION OF JUVENILE EMPLOYMENT AND WELFARE OFFICERS:

RESOLVED TO RECOMMEND—

THAT the annual subscription of one guinea for the year ending 31st March, 1940, be paid to the National Association of Juvenile Employment and Welfare Officers.

Moved by Councillor Lightfoot, seconded by Mrs. Bannister, and RESOLVED—

THAT the Report (as amended) of the Juvenile Employment Sub-Committee be approved and adopted.

BURNT OAK SCHOOL—STRIPPING AND RETILING ROOF:

The Borough Surveyor reported on tenders received for stripping and retiling the roof of Burnt Oak School. Details of the tenders are given in the lists circulated to members and set out in MSS. in the Works Sub-Committee's Minute Book. Subject to the usual financial inquiries proving satisfactory and to approval by the Board of Education, it was

RESOLVED TO RECOMMEND—

THAT the lowest tender, namely that of Messrs. Roberts & Burling, Ltd., amounting to £399 13s. 3d., be accepted for carrying out the work, and that the Corporate Seal be affixed to the contract.

Amendment

Before detailed consideration of the motion, the Finance and General Purposes Committee in concurring with the proposal Recommend—That the following words be added after the word "accepted":—

"subject to the usual financial enquiries."

AIR RAID PRECAUTIONS—PRELIMINARY SCHEME:

Moved by Alderman Copestake, duly seconded, and RESOLVED—

THAT this matter be dealt with in Committee.

DOLE STREET COUNCIL SCHOOL—CHANGE OF NAME:

Consideration was given to a letter from Mr. H. Tees suggesting, for the reasons mentioned, that the name of this School be changed.

RESOLVED—

THAT the Dole Street Council Junior and Infant School be re-named Dollis Council Junior and Infant School, and that the Board of Education be informed accordingly.

ST. PAUL'S C.E. SCHOOL:

It was reported that Mr. R. Hare had been appointed as Correspondent to the Managers of this School, *vice* Mr. James Fraser, resigned. **Noted.**

RESOLVED—

THAT the nomination of a representative to serve on the Body of Trustees for a period of three years be referred to the Borough Council.

Report (No. 2) of the Education Committee (in Committee).

23rd May, 1939.

COMMITTEE:

*Alderman J. J. Copestake, J.P. (*Chairman*).

Aldermen:

S. H. Egan, J.P.,
B. Flowers,

*W. M. Maughan, J.P.,

B. J. Monro.

Councillors:

*E. Arter, M.C., M.I.A.E.,
*H. Connell, J.P.,
*A. W. Curton,
*G. H. Hignett,
*P. Lightfoot,

*A. A. Naar, M.B.E.,
(Mrs.) F. E. Parvin,
T. Pugh,
C. R. Richardson,
T. J. Scott,

W. H. N. Shakespeare,
M.C., A.F.C., J.P.,
*H. P. Small,
(Mrs.) M. Thomas.

Co-opted:

*Mrs. S. J. Bannister,
L.L.A.,
*The Rev. N. R. Boyd,
M.A.,

*Major N. C. Brett
James, M.A.,
B.Litt., F.S.A.,

*The Rev. P. C. Howell.
*The Rev. I. Livingstone.

* denotes Member present.

Apologies for absence were submitted on behalf of Aldermen Egan, Flowers and Monro, and Councillors (Mrs.) Parvin, Richardson, Scott and Shakespeare.

CASE OF MRS. C. HARROP:

The Director of Education submitted particulars of this case and the School Medical Officer reported thereon.

RESOLVED—

THAT payment of salary to Mrs. Harrop up to the end of June, 1939, be approved, and that the case be re-considered, together with a further report thereon by the School Medical Officer at the next meeting of the Staffs and Salaries Sub-Committee.

AIR RAID PRECAUTIONS IN SCHOOLS:

(a) A memorandum from the Town Clerk and a secret communication from H.M. Office of Works, regarding schools reserved in the event of an emergency, were submitted and **noted with satisfaction**.

(b) Consideration was also given to a preliminary report on Air Raid Precautions in Hendon Elementary Schools. The Director of Education submitted particulars of action which is being taken by neighbouring Authorities as the result of Board of Education Circular 1467.

RESOLVED—

- (a) **THAT** further consideration of the above-named preliminary report be deferred for the time being.
- (b) **THAT** the Director of Education be instructed to report on the question of providing a permanent holiday and educational camp, and also on the possibility of utilising such camp for evacuation purposes in the event of a national emergency.

Report of the Public Health and Medical Services Committee.

15th May, 1939.

COMMITTEE :

*Councillor T. J. Scott (*Chairman*).

Aldermen:

*W. R. Clemens, F.C.A.,

*B. Flowers,

*W. M. Maughan, J.P.

Councillors:

*F. W. Gilpin,

*P. Lightfoot,

*C. R. Richardson,

*G. H. Hignett,

*C. Pinkney,

*H. P. Small.

*L. Hirshfield,

(Mrs.) M. Thomas.

Co-opted Members:

†Mrs. S. J. Bannister,
L.L.A.,

†Mrs. W. M. Maughan,
†Mrs. B. J. Monro, J.P.,

†The Rev. P. G. Howell.

* denotes Member present.

† Denotes Co-opted Member present on Parts I. and II.

Part I.—Medical Services.

1.—STATISTICAL INFORMATION :

Information as to Maternity and Child Welfare Services and attendances at Health Centres was submitted for the four weeks ended on the 6th May, 1939 (see statistical tables—Appendix to the report of the Finance and General Purposes Committee, page 9).

CHILD LIFE PROTECTION.

2.—NEW APPLICATIONS :

The Medical Officer reported the receipt of applications (Cases No. 269-74 inclusive) to undertake for reward the nursing and maintenance of children under nine years of age.

RESOLVED TO RECOMMEND—That the maximum number of children under the age of nine years that may be kept at the premises in question be fixed at one in cases 269-73 inclusive, and two in case No. 274.

3.—CHANGE OF ADDRESS :

Notification of change of address (Case No. 234) was reported.

RESOLVED TO RECOMMEND—That the maximum number of children under the age of nine years that may be kept at the new premises be fixed at one.

4.—CASE NO. 231 :

The Council on the 20th June, 1938 (P.H. & M.S.C., 16/5/38—5) resolved that the maximum number of children under the age of nine years that may be kept at the premises in question be fixed at one, subject to review at the expiration of a period of twelve months.

RESOLVED TO RECOMMEND—That the existing arrangements for the care of the foster child in this case be continued for a further period of twelve months.

5.—CONVALESCENT TREATMENT:

The Medical Officer reported with regard to the cases of S.M. and F.M., N.W. 2.

RESOLVED TO RECOMMEND—That arrangements be made for the children in question to be sent away for a period of six weeks' convalescence.

6.—PARK SHELTERS:

The Committee considered the communication, deferred from the last Meeting, from the National Society of Day Nurseries on the subject of Park Shelters for the benefit of children under five years of age, but have no recommendation to make on the communication from the Society.

Arising out of this matter, however, reference was made to the advisability of providing a Public Shelter in York Park, West Hendon, and it was

RESOLVED—That the attention of the Estates, Parks and Allotments Committee be called thereto.

7.—BRITISH DENTAL ASSOCIATION:

A communication inviting the Council to appoint a Dental Officer to attend the Annual Meeting of the above-named Association to be held at Newcastle-on-Tyne from 31st July to 3rd August was reported, but it was decided to take no action in the matter.

8.—LIQUID MILK:

A communication was considered from the Council of the County Borough of Bournemouth intimating that they have had under consideration the question of the price of liquid milk supplied under their Maternity and Child Welfare Scheme for expectant and nursing mothers and children under school age.

The Bournemouth Corporation have applied to the Milk Marketing Board to allow a rebate on milk supplied by local authorities in connection with their maternity and child welfare services, and they are approaching the Association of Municipal Corporations asking them to consider taking steps to secure such rebate. The support of this Council was enlisted in the matter.

RESOLVED TO RECOMMEND—That the Council support the action taken by the County Borough of Bournemouth.

9.—REQUISITIONS:

Requisitions amounting to the sum of £183 8s. 5d. were submitted and **approved.**

Part II.—Medical Services for approval by the Hendon Education Committee.

(See Education Minutes, Pages 778-779.)

Part III.—Public Health.

10.—STATISTICAL INFORMATION:

Information was submitted for the four weeks ended on the 6th May, 1939. (See statistical tables—Appendix to the report of the Finance and General Purposes Committee, page 9.)

11.—MILK AND DAIRIES (CONSOLIDATION) ACT, 1915,
MILK AND DAIRIES (AMENDMENT) ACT, 1922,
MILK AND DAIRIES ORDER, 1926:

Applications were reported from the under-mentioned for registration as retail purveyors of milk within the Borough, and from the last named for registration as Dairy-men.

Name and Address of Applicant.	Source of Milk Supply.
John Jack Segar, 7, Thornfield Parade, Holders Hill Road, Mill Hill, as a retail purveyor of milk in respect of the premises named	Bladen Dairies Ltd., Millbourne St. Andrews, Dorset. (Milk in sealed cartons only.)
Henry James Bennett, 52, Glengall Road, Edgware, as a purveyor of milk in respect of the premises named	Bladen Dairies Ltd., Millbourne St. Andrews, Dorset. (Milk in sealed cartons only.)
Bury Farm Ltd., Bury Farm, Edgwarebury Lane, Edgware, in respect of the premises named	Bury Farm, Edgwarebury Lane, Edgware.

RESOLVED TO RECOMMEND—That the applicants be registered accordingly.

12.—STATUTORY NOTICES:

RESOLVED—That Statutory Notices be served in the following cases:—

Section 93, Public Health Act, 1936:—

- 38a, Oak Grove, Cricklewood.
- 34, Prospect Road, Child's Hill.
- Land rear of Edgware Motors Ltd., Deansbrook Road, Edgware.
- 14a, Second Avenue, Hendon.

Section 75, Public Health Act, 1936:—

- 34, Prospect Road, Child's Hill.

Section 45, Public Health Act, 1936:—

- 9, Herbert Road, West Hendon.
- 7, Hillerest Avenue, Golders Green.

Notices under Section 93 and 259, Public Health Act, 1936:—

- Watercourse passing through land belonging to "Graystanes," Marsh Lane at boundary of Sunnyfields Estate, Mill Hill.

13.—REGISTRATION OF HAWKERS AND HAWKERS PREMISES:

The following applications were reported:—

James Emery	4, Deansbrook Road, Edgware.	For the sale of Fish.
Thomas Filbey	26, Edenham Street, W. 10.	For the sale of vegetables.
Miss L. M. Crow	Mill End, Thaxted, Essex.	For the sale of farm produce (meat food products, fruit and vegetables).

(Food stores used by the aforementioned persons are not situate within the Borough of Hendon; their suitability as such has been verified by the respective Local Authorities.)

Frederick Richard Fisk	44, Aldridge Avenue, Edgware.
------------------------	-------	-------	-------------------------------

Hawkers Premises (storage accommodation):—

Premises.	Occupier.	Food.
Lock-up brick built garage, 44, Aldridge Avenue, Edgware	Frederick Richard Fisk, 44, Aldridge Avenue, Edgware	Fruit and Vegetables.

RESOLVED TO RECOMMEND—That the aforesaid persons and/or premises be registered with the Local Authority in accordance with the requirements of Section 71 Middlesex County Council (General Powers) Act, 1938.

14.—SHOPS ACT, 1934:

Provision as to Sanitary and other arrangements in Shops.

Pursuant to instructions the Medical Officer has reported on the administration of the Shops Act in relation to the provision and maintenance of suitable and sufficient sanitary conveniences, and suitable and sufficient means for the provision and maintenance of reasonable temperature in shops.

Sanitary Conveniences.

Section 10 (2) of the Act provides that in every shop, not being a shop exempted from the provisions of this sub-section, there shall be provided and maintained suitable and sufficient sanitary conveniences available for the use of persons employed in or about the shop; and Section 10 (6) that a shop shall be exempted from the provisions of sub-section (2), of this section if there is in force a certificate exempting that shop therefrom, but no such certificate shall be granted unless the authority are satisfied that by reason of restricted accommodation or other special circumstances affecting the shop it is reasonable that such a certificate should be in force and that suitable and sufficient sanitary conveniences are otherwise conveniently available.

The Act does not lay down any standard requirements, but provides that the required facilities shall be "suitable and sufficient," which means, in relation to any shop or part of a shop, suitable and sufficient having regard to the circumstances and conditions affecting that shop or part. The effect of this definition is that the requirements have to be considered in the light of the circumstances and conditions of the individual shop. These will include not only the size of the shop and the number and sex of the assistants employed, but also the nature of the trade carried on.

It has been the practice to ask for the provision of separate sanitary accommodation in shops where persons of each sex are employed, irrespective of their number, and where sufficient space is available, and in the event of such requisition not being complied with a report has been submitted to the Committee with particulars of the case and generally a recommendation that authority be given for the service of a statutory notice has been approved.

In cases where it has not been possible to provide additional accommodation reports recommending the granting of exemption have been submitted and certificates issued.

From information obtained from other districts in the County it would appear that in clean trades the general practice is not to require the provision of two conveniences where persons of each sex are employed and where their total number does not exceed three, providing suitable automatic signs on convenience doors are in use. In all other cases where separate sanitary conveniences for each sex are not provided it is left to the department to agree to accommodation which is considered reasonable, or in the event of difficulty to report to the Committee for instructions.

Temperature.

Section 10 (1) provides that in every part of a shop in which persons are employed about the business of a shop suitable and sufficient means shall be provided to maintain a reasonable temperature and a reasonable temperature shall be maintained.

No standard has been laid down except that the means provided shall be "suitable and sufficient" and in deciding whether or not a temperature is reasonable, important considerations are the nature of the tasks performed by the assistants, *i.e.*, whether those tasks are in themselves heavy or light, and also the extent to which the workers move about from one place to another. There is also the question of closed shops" and "open shops" each selling either perishable or non-perishable goods.

The Factories Act, 1937, requires a temperature, after the first hour, of not less than 60°F. in workrooms in which a substantial proportion of the work is done sitting and does not involve serious physical effort; and as a general rule temperatures of not less than 60°F should be aimed at where the workers are engaged on light work, whether they stand or sit.

RESOLVED TO RECOMMEND—

- (1) **That in connection with the provision of sanitary conveniences in existing shop properties, the Council's practice, referred to in the report of the Medical Officer, be continued.**
- (2) **That the Town Clerk be requested to report as to the powers of the Council to require a minimum of two sanitary conveniences in connection with the erection of new shops.**
- (3) **That a temperature of 55°F be regarded as a minimum for shops generally, but in a shop or part of a shop in which the occupation is of the sedentary character the minimum shall be 60°F.**

15.—ISOLATION HOSPITAL:

Careful consideration was given to the communication from Mr. Trevor Jones on the subject of fees which was deferred from the last meeting. The observations of the Medical Superintendent on the matter were also considered.

The present arrangement is as follows:—

- (a) A retaining fee of 150 guineas per annum is paid to Mr. Trevor Jones.
- (b) No fees are paid for consultations or visits.
- (c) That if the total fees in respect of operations calculated on the following basis exceeds the retaining fee the amount payable is increased accordingly:—

	£	s.	d.
Double Mastoidectomy or Major Abdominal operation.....	15	15	0
Single Mastoidectomy or Major operation, not abdominal	10	10	0
Other surgical procedure depending upon extent of operative interference	5	5	0
		or 3	3 0

RESOLVED TO RECOMMEND—That the Council adhere to the existing arrangement, subject to facilities being granted for a holiday period not exceeding four weeks per annum (during which the Council undertake to pay a locum) by arrangement with the Medical Superintendent.

[Having considered the matter in its financial bearing, the Finance and General Purposes Committee concur in the proposal.]

16.—ROTA REPORT:

The following report was submitted:—

To the Public Health and Medical Services Committee.

We, the undersigned members, submit the following report of a visit made to the above-named Hospital, on Monday, 8th May, 1939.

We have visited the whole of the hospital and are satisfied that everything is being carried on in a satisfactory manner.

There are one or two items which require attention, viz.:—

We recommend that the Borough Surveyor be asked to report on the possibility of providing alternative accommodation in place of the coal-shed serving the wards and administrative block, in order to release the present shed for use as a pantry.

One of the external vent pipes from the kitchen to the administrative block courtyard requires attention and we suggest that this be dealt with by the Borough Surveyor.

In order to avoid disturbance of the patients we recommend that the Post Office telephone in Block 1 be removed from its present position in the hall and placed in the ward kitchen.

Instructions have been given with regard to another minor matter.

(Signed) T. J. SCOTT (Chairman),
GEO. R. RICHARDSON,
H. P. SMALL.

RESOLVED TO RECOMMEND—That the report of the Rota be approved and adopted.

17.—EMPIRE HEALTH WEEK—1st-7th OCTOBER, 1937:

It was decided to take no action with regard to a communication from The Royal Sanitary Institute on the above subject.

18.—COLNE VALLEY WATER:

The Medical Officer reported on analyses of water supplied by the above Company which was stated to be of high grade. **Noted.**

19.—SMOKE ABATEMENT:

A communication was submitted from the Greater London Advisory Council for Smoke Abatement forwarding a copy of the constitution of the Advisory Council, and expressing the hope that the Town Council would re-consider the question of membership.

The Committee have no recommendation to make thereon.

20.—ANNUAL REPORT OF MEDICAL OFFICER OF HEALTH, 1938:

The Committee gave authority for the printing of the required copies of the above report.

21.—WATERCOURSE—DEVONSHIRE ROAD, BETWEEN NOS. 74 AND 76:

The Council on the 27th March, 1939 (P.H. & M.S.C., 6/3/39-14) gave authority under Section 93 of the Public Health Act, 1936, to enter and efficiently clean the bed and banks of the watercourse. A communication has been reported from the Hendon Ratepayers' Association expressing the view that the watercourse in question should be piped in. **Noted.**

22.—REQUISITIONS:

The following requisitions were submitted and **approved** subject to further enquiry with regard to a minor item in requisition "D":—

	£	s.	d.
"D"—Isolation Hospital	62	4	2
"C"—Public Health Department	14	14	6

Report of the Highways Committee.

15th May, 1939.

COMMITTEE:

*Councillor A. W. Curton (*Chairman*).

Aldermen:

*J. J. Copestake, J.P.,

*A. J. Reynolds, J.P.,

F. C. Rice.

Councillors:

*E. Arter, M.C., M.I.A.E.,

*J. Griffiths,

*C. J. Pryke, F.I.A.C.,

*H. Connell, J.P.,

*A. A. Naar, M.B.E.,

A.M.I.S.E.,

*A. W. Greville,

H. C. Potter, J.P., F.S.I.

*C. F. Windust.

(*Mayor*),

* denotes Member present.

1.—REQUISITIONS:

Requisitions amounting to £3,602 17s. 6d. were submitted and **approved**.

STREET TRADING.

2.—WATLING AVENUE:

The Committee received a deputation consisting of Messrs. Douglas Martin, H. R. Parsons, and A. J. Scarles, on behalf of the Hendon Chamber of Commerce regarding street trading in Watling Avenue. The deputation stated that in the opinion of the Chamber of Commerce street trading was wrong in principle as it was unfair (particularly with the present depression of trade) and in direct competition with the shop keepers who have to pay rates, etc. It was urged by the deputation that street trading in Watling Avenue would add seriously to the congestion of this thoroughfare, and that if street trading is to be permitted in the neighbourhood such trading should be carried on in the side streets leading out of Watling Avenue.

The deputation thanked the Committee for receiving them and expressed the hope that the Council would not permit street trading in the road in question.

The Committee also considered a petition submitted by the Watling Street Traders' Association and signed by 39 shop keepers in Watling Avenue in favour of the proposal to grant a limited number of street trading licences to local persons in respect of Watling Avenue.

The Commissioner of Police (Hi.C., 6/3/39—5) has called attention to the bad accident record and the considerable volume of traffic, including three services of omnibuses, which traverses the road, and intimates that he is of opinion that the road is potentially dangerous and considers it would be most undesirable from a traffic point of view, to grant licences to street traders in respect of Watling Avenue. (Hi.C., 17/4/39—2).

The Council (Hi.C., 6/3/39—11) approved a scheme for the establishment of a car park to relieve traffic congestion in Watling Avenue and the proposal is now waiting the consent of the London County Council.

RESOLVED TO RECOMMEND—That an enquiry be made of the Commissioner of Police as to whether in his opinion the establishment of the proposed car park would adequately relieve traffic congestion to permit of the issue of a limited number of street trading licences in respect of Watling Avenue.

PRIVATE STREET WORKS.**3.—TENDERS:**

The Borough Surveyor reported that in view of the priority to be given to matters relating to Air Raid Precautions (A.R.P.C., 19/4/39—6) he proposed to defer for the time being, advertising for tenders for the making up of those private streets, which have been approved in principle by the Minister of Health. **Noted and approved.**

TRAFFIC.**4.—PEDESTRIAN CROSSING, STATION ROAD, EDGWARE:**

A letter was submitted from the Minister of Transport approving pursuant to Section 48 (1) of the Road Traffic Act, 1930, the pedestrian crossing, opposite No. 103, Station Road, Edgware. **Noted.**

5.—JUNCTION OF HENDON WAY WITH THE NORTH CIRCULAR ROAD:

A letter was submitted from the Minister of Transport in reply to the Council's request for a deputation to be received regarding the unsatisfactory traffic conditions at the above junction. It was intended to urge the Minister to reconsider, in view of the uncertainty of the date of commencing the work of construction of the intended "fly-over" (Bressy Report), the provision of a straight over crossing in substitution of the existing roundabout, but the Minister states that the proposal has been carefully considered, and he cannot see his way to modify his decision in the matter. In these circumstances, the Minister does not feel that he would be justified in agreeing to the Council incurring the expense of sending a deputation to discuss the matter. (Hi.C., 6/3/39—15).

In view of the repeated observations made of the traffic conditions at this junction, where exceptional congestion occurs necessitating Police control, the Committee

RESOLVED TO RECOMMEND—

- (1) **That the Minister again be urged to re-consider his decision and to receive a deputation from the Council on the matter.**
- (2) **That the Middlesex County Council be asked to support the Council's proposal for the immediate provision of a straight-over crossing at this junction.**
- (3) **That a copy of the above resolutions be forwarded to the Member of Parliament for Hendon (Sir Reginald Blair).**

6.—SPEED LIMIT, HENDON WAY—WATFORD WAY:

The Town Clerk reported the receipt of a letter from the Minister of Transport enclosing a copy of the Order which has been made under Section 1 (4) (b) of the Road Traffic Act, 1934, imposing a speed limit in the section of Hendon Way/Watford Way, between Park Road and The Burroughs, Hendon. (Hi.C., 17/4/39—12). **Noted.**

7.—HACKNEY CARRIAGE STANDING, STATION ROAD AND PENSURST GARDENS, EDGWARE:

The Commissioner of Police has transmitted, for the information of the Council, a copy of regulations made by him pursuant to Section 4 of the London Hackney Carriages Act, 1850, governing the cancellation and re-appointment of a hackney carriage standing at Station Road and Penshurst Gardens, Edgware. The effect of this is to permit a standing for 2 cabs on the east side of Station Road immediately north of the entrance to the forecourt of Edgware Underground Station and 4 cabs on the north side of Penshurst Gardens at a point two yards east of the side entrance to the National Provincial Bank. **Noted.**

TRAVELLING FACILITIES.**8.—OMNIBUS SERVICE NO. 121:**

The London Passenger Transport Board give notice, that commencing as from the 7th May, Omnibus Service No. 121 operating on Sundays and Bank Holidays between Canons Park and Nunhead will be withdrawn. To compensate for this withdrawal Service No. 3 on these days will be withdrawn between Camden Town and Oxford Circus and diverted to Edgware Station (Underground) via the thoroughfares traversed by Service No. 121 and renumbered 3a. To cover the withdrawal of the section between Edgware Station and Canons Park, Service No. 114 will be augmented between these points. The Committee have duly noted the communication, and

RESOLVED TO RECOMMEND—That the London Passenger Transport Board be requested to provide an additional omnibus service or alternatively additional trolley buses on the route from Edgware Station (Underground) traversing High Street and Stone Grove to Canons Park.

9.—EDGWARE ROAD STOPPING PLACES:

The Town Clerk reported the receipt of a letter from the Minister of Transport regarding the operation for an experimental period of three months commencing on the 24th May, 1939, of stopping places for omnibuses in Edgware Road at the Hendon Trolley Bus Dépôt.

The Committee have no observations to offer on the proposal.

IMPROVEMENT SCHEMES.**10.—FINCHLEY ROAD IMPROVEMENT (PORTSDOWN AVENUE TO CRICKLEWOOD LANE):**

The Borough Surveyor reported that satisfactory progress is being maintained in connection with this improvement and details of the work proceeding on the various sections of the road were submitted. (H.C., 17/4/39—16). **Noted.**

11.—BITTACY HILL BRIDGE—RECONSTRUCTION AND IMPROVEMENT:

In connection with the two Schemes "A" and "B" amounting to £38,800 and £36,050 respectively, which were submitted to the Minister of Transport and the Middlesex County Council with the Council's recommendation that Scheme "A" be approved, the Borough Surveyor reported that the Minister has now approved in principle Scheme "A." The scheme comprises both the reconstruction of the London and North Eastern Railway Bridge and the widening and improvement of the road in connection with which it has become necessary to submit revised estimates in three sections as follows:—

Estimate No. 1:—	£
Road and accommodation works, Vineyard Avenue to a point 115 yards north of the same	1,820
Estimate No. 2:—	
Road and accommodation works, including bridge works from the last point to Bittacy Road	27,900
Estimate No. 3:—	
Road and accommodation works, Bittacy Road to Sanders Lane	5,900
Total	£35,620

It is anticipated that the Minister will pay 50 per cent. of the Estimates Nos. 1 and 3. As regards No. 2 a grant of 75 per cent. is contemplated and the estimate is conditional upon the Railway Company paying a sum of £6,634 as their proportion having regard to their liabilities under the Great Northern Railway Act, 1898.

A sum of £481 will have to be provided by the Council in respect of its proportion (40 per cent.) of the cost of the new surface water sewer included in the Scheme. (Hi.C., 6/2/39—15).

RESOLVED TO RECOMMEND—

- (i) **That the plans and revised estimates amounting to £35,620 be approved and submitted to the Middlesex County Council and the Minister of Transport, and authority given for an agreement to be entered into with the London and North Eastern Railway Company in a form to be approved by the Town Clerk.**
- (ii) **That the Corporate Seal be affixed to any necessary documents in connection therewith.**

[Having considered the matter in its financial bearing, the Finance and General Purposes Committee concur in the proposal.]

12.—STATION ROAD, EDGWARE, BETWEEN MANOR PARK CRESCENT AND EDGWAREBURY LANE:

The Borough Surveyor reported that it had been found necessary to replace the existing concrete foundation of the road and that the Middlesex County Council had duly approved an amended scheme submitted to them for carrying out the required works. Work on the scheme was re-commenced on the 10th May. (Hi.C., 6/3/39—22). **Noted.**

13.—FOULING OF FOOTPATHS BY DOGS:

The Committee considered the under-mentioned suggestion of the Hampstead Garden Suburb Residents' Association, referred from the Public Health and Medical Services Committee (17/4/39—28):—

“That road scavengers be directed to clean footpaths at the same time as roads.”

The Borough Surveyor reported that both the footpaths and carriageways of ordinary residential streets are cleaned and swept three times a week and the Committee suggest that the Public Health and Medical Services Committee further consider the matter in relation to the Council's Byelaws.

as from the
lays between
withdrawal
and Oxford
res traversed
tion between
between these

ort Board be
y additional
traversing

f Transport
neing on the
the Hendon

KLEWOOD

aintained in
the various

38,800 and
the Middle-
e approved,
ple Scheme
rth Eastern
ction with
follows:—

£

ards
1,820

ast
27,900

5,900

£35,620

Report of the Estates, Parks and Allotments Committee.

15th May, 1939.

COMMITTEE:

*†Councillor F. J. Collins (*Chairman*).

Aldermen:

S. H. Egan, J.P.
(*Deputy Mayor*),

*†B. J. Monro.

*†R. A. B. Teare, M.B.E.

Councillors:

*†F. H. Bate,
*†T. K. Bridge,
*†E. J. Cox,

*†W. A. Hicks,
*†(Mrs.) F. E. Parvin,
*†T. Pugh,

*†J. H. Rodway,
*†W. H. N. Shakespeare,
M.C., A.F.C., J.P.

Co-opted Members:

H. J. Ellner,
†T. W. Hammond,

†P. Kneip,

†G. Thompson.

• denotes Member present.

† Denotes Member present at Allotments Committee.

1.—REQUISITIONS:

Requisitions amounting to £286 15s. 1d. were submitted and approved.

2.—COMMUNITY CENTRE—CLITTERHOUSE AREA:

The Committee have considered the reference from the Council of the 8th May on the resolution of the Education Committee (25/5/39) as to the availability of land at Clitterhouse Open Space, and in connection therewith it has been reported that an enquiry had since been received from the County Education Authority as to whether the Hendon Town Council would consider the possibility of placing a site at the disposal of the County Council as a contribution towards a Community Centre for the Clitterhouse area on the understanding that the County Council provide the building in its capacity as the Higher Education Authority.

It is understood that the type of Community Centre envisaged for this area would cost, approximately, £4,500 to £5,000 and would provide a main hall 60 ft. x 30 ft. with dressing rooms, two Committee rooms, a common room, games room, dry canteen and office accommodation.

The Committee have considered the question of the allocation of a site and are prepared to consent to the use of approximately one-half acre of the Clitterhouse Open Space near the entrance from Claremont Road adjacent to the northern boundary of the land leased to the Golders Green Football Club. The site proposed is, however, subject to certain restrictive covenants.

RESOLVED TO RECOMMEND—

- (1) That the Education Committee be authorised to inform the County Education Authority, that, subject to the consent of the Minister of Health and to the removal of the restrictive covenants, the Hendon Town Council are prepared to grant a lease of 21 years on approximately one-half acre of land at a nominal rental, on the Clitterhouse Open Space for the erection of a Community Centre.

- (2) That the Finance and General Purposes Committee be requested to determine the nominal rental under the proposed lease.

Amendment

Before detailed consideration of the motion, the Finance and General Purposes Committee Recommend—That the following be inserted after the word "rental":—

"of £10 per annum"

and that Recommendation 2 be deleted.

3.—THE MILL FIELD—MILL HILL SOCIAL SERVICE COMMITTEE:

A letter was submitted asking for permission for sideshows to be arranged at the lower end of the Mill Field in connection with a Garden Fête to be held at "West Grove," Hammers Lane, in aid of funds for the Mill Hill Social Service Committee, on the 15th July next.

RESOLVED TO RECOMMEND—That the application for the use of the lower end of the Mill Field be approved, subject to the Council being fully indemnified against all costs and claims arising out of the user, and an undertaking being given to make good any damage to the property.

Amendment

Before detailed consideration of the matter, the Finance and General Purposes Committee Recommend—That the following be inserted after the word "user":—

"Such indemnity to be covered by insurance if necessary."

4.—SCHOOLS' SPORTS:

The Committee have considered an application from the Director of Education for permission for seven schools to hold their annual sports in certain of the Council's Open Spaces.

In view of the fact that some of the school sports are to be held very shortly, the Committee, as a matter of urgency,

RESOLVED—

- (1) That consent be granted subject to any expenditure incurred being charged to the Education Accounts.
- (2) That the Borough Surveyor be authorised to make the necessary arrangements.

5.—HORSE RIDING IN PARKS:

The Committee have commenced a review of the existing facilities for horse riding in Arrandene and Burtonhole Lane Open Spaces, but before finally reporting thereon it is proposed to take a census of riders over a period of one month.

6.—BOWLING GREENS—MILL HILL AND WATLING PARKS:

Pursuant to instructions (E.P. & A.C., 17/4/39—11) the Borough Surveyor submitted plans for the erection of a temporary building (12 ft. x 8ft.) at the Mill Hill Bowling Green for use by the Ladies' Club, at an estimated cost of £50. As no facilities for shelter or storage exist for the green in Watling Park it is proposed that a similar building be erected adjacent to the Bowling Green for use not only by the public playing on the green and the Watling Association but also by the greenkeeper for the storage of bowls and equipment.

RESOLVED TO RECOMMEND—That the plans and estimates amounting to £50 per hut be approved and that the Borough Surveyor be authorised to carry out the proposed works at Mill Hill and Watling Parks.

[Having considered the matter in its financial bearing, the Finance and General Purposes Committee concur in the proposal.]

7.—MOAT MOUNT OPEN SPACE—CYCLE RACK—YOUTH ORGANISATIONS COMMITTEE:

A letter was submitted from the Youth Organisations Committee asking the Council to erect a small lean-to building with a proper floor as they are desirous of fixing a cycle rack at the rear of the Headquarter's hut at Moat Mount.

RESOLVED TO RECOMMEND—That the Borough Surveyor be authorised to erect a lean-to shed at an estimated cost of £5.

[Having considered the matter in its financial bearing, the Finance and General Purposes Committee concur in the proposal.]

8.—ENTERTAINMENTS FOR CHILDREN:

Pursuant to instructions (E.P. & A.C., 6/3/39—2) the following quotations have been obtained for entertaining children in the parks and open spaces:—

Mr. A. Potter, Mill Hill	£3 3s. 0d. per hour.
Mr. Beaumont, South Norwood	£4 4s. 0d. per hour.

An expenditure of £10 has been included in the Rate Estimates, 1939/40, for each of the following parks:—

Hendon Park.
Child's Hill Park.
Watling Park.
Clitterhouse Playing Fields.
West Hendon Playing Fields.

RESOLVED TO RECOMMEND—That the quotation of Mr. A. Potter, amounting to £3 3s. 0d. per hour, be accepted for three one-hourly performances in each of the above-mentioned Parks during the Schools Summer Holidays.

[Having considered the matter in its financial bearing, the Finance and General Purposes Committee concur in the proposal.]

9.—APPRENTICESHIP SCHEME:

Applications were received from Mr. D. Lovatt of 82, Cumbrian Gardens, and Mr. R. Connolly of 22, Wolsely Grove, in connection with the Apprenticeship Scheme. (E.P. & A.C., 27/6/38—3).

Under the scheme the number of apprentices are restricted to three each alternate year and of this number two have already entered subject to their passing a satisfactory medical examination. Consequently only one more apprentice can be engaged before 1941.

RESOLVED TO RECOMMEND—

- (1) **That the application of Mr. D. Lovatt for apprenticeship be approved subject to his passing a satisfactory medical examination.**
- (2) **That Mr. R. Connolly be informed that the Council regret they are unable at the present time to accept his application for apprenticeship.**

10.—ARRANDENE OPEN SPACE—FENCING:

Pursuant to instructions (E.P. & A.C., 14/11/38—7) the Town Clerk reported on the liability of the Council in respect of fencing and in the case in question no liability rests with the Council.

RESOLVED TO RECOMMEND—That Miss Crampton be informed accordingly.

11.—SCRATCHWOOD OPEN SPACE:

The Town Clerk reported that the owner of Bays Hill Cottage was prepared to abandon his claim to enter Scratchwood from the gate on the south side of his property, but that the claim to cart manure and other materials in connection with the garden of Bays Hill Cottage appears to be substantiated, subject to the preparation and production to the Council of Statutory Declarations in support.

It appears reasonable, in order to avoid litigation, that the matter should be settled in this way and that the Council should allow the sum of ten guineas towards the costs of the Claimant's Solicitor in respect of the Statutory Declarations to be prepared and correspondence.

RESOLVED TO RECOMMEND—That authority be given for payment of the sum of ten guineas towards the costs incurred by the Claimant.

[Having considered the matter in its financial bearing, the Finance and General Purposes Committee concur in the proposal.]

12.—CHILDREN'S PLAYGROUNDS—EQUIPMENT:

The Borough Surveyor reported that an exhaustive inspection and examination had been made of the playground equipment in the various parks and open spaces and that it was considered necessary to replace and/or provide new equipment in no less than nine playgrounds. Details of equipment proposed have been carefully considered and the estimated costs are—replacements and repairs £164, and new apparatus £144—Total £308.

Consideration has also been directed to the advisability of retaining children's slides which tend to be the cause of accidents generally through improper use. In order to obviate any possible source of danger in this respect the Committee are of opinion that the slides should be removed and it is proposed to consider what type of apparatus should be substituted.

RESOLVED TO RECOMMEND—

- (1) **That all slides in children's playgrounds in the Council's Open Spaces be removed and replaced by other suitable apparatus.**
- (2) **That the Borough Surveyor be instructed to carry out the proposed replacements and repairs referred to in his report and to obtain tenders for the suggested new equipment.**
- (3) **That the Finance and General Purposes Committee be requested to provide the sum of £500 to meet the costs involved.**

[Having considered the matter in its financial bearing, the Finance and General Purposes Committee concur in the proposal.]

13.—PARKS DEVELOPMENT—TENDERS—EDGWAREBURY PARK—PAVILION AND DRESSING ROOMS—WATLING PARK—BANDSTAND AND SHELTER:

The Town Clerk reported receipt of tenders for the above works.

RESOLVED—That such tenders be opened, initialled by the Chairman and referred to the Borough Surveyor for report.

14.—PARKS AND OPEN SPACES—CULTIVATION:

Reference was made to the general appearance of the Parks and Open Spaces and in particular to the very high standard of cultivation which has been achieved in Hendon and Watling Parks. The Committee on behalf of the Council expressed their thanks to the Parks Superintendent and requested him to convey to the Parks' Staff their appreciation of the successful work in the Parks and Open Spaces generally.

ALLOTMENTS COMMITTEE.

15.—SURPLUS (SEWAGE DISPOSAL) LAND—NORTH OF THE RIVER BRENT:

The Committee have duly noted the Council's decision regarding the re-allocation of part of the above land for Housing purposes (Housing Committee, 24/4/39—13), together with the following resolution of the Hendon Federation of Allotment Societies which is submitted for information:—

“That this Federation of Allotment Societies views with considerable concern the decision of the Hendon Borough Council to apply to the Ministry of Health for permission to appropriate 12½ acres of allotment land at Brent Hill for Housing purposes, particularly bearing in mind the terms of the Circular Letter received from the Ministry of Agriculture and Fisheries. We, therefore, urge the Council to re-consider the whole position with the object of abandoning the project to erect additional houses in this part of the district.”

16.—DAWS LANE ALLOTMENTS:

A letter was submitted from the Hendon Federation of Allotment Societies regarding the notices to quit which had been served upon five allottees occupying allotment plots at Daws Lane.

The Town Clerk reported that the notices to quit expire on the 8th November, 1939, but alternatively the allottees had been informed that in the event of possession being given up by the 15th June, 1939, the date when the Postmaster General is desirous of commencing building operations on this land, compensation would be payable by the Council. **Noted.**

17.—NATIONAL ALLOTMENT SOCIETY LTD.:

An invitation was received from the above Society to appoint delegates to attend the Annual Conference to be held at Cambridge from the 29th June to the 1st July, 1939.

RESOLVED TO RECOMMEND—That Councillor E. J. Cox be appointed to attend such Conference.

[Having considered the matter in its financial bearing, the Finance and General Purposes Committee concur in the proposal.]

Report of the Works and Fire Brigade Committee.

22nd May, 1939.

COMMITTEE:

*Councillor A. A. Naar, M.B.E. (Chairman).

Aldermen:

B. J. Monro.

*A. J. Reynolds, J.P.,

*F. C. Rice.

Councillors:

*F. J. Collins,

*A. W. Greville,

*J. H. Rodway,

*H. Connell, J.P.,

(Mrs.) F. E. Parvin,

*C. F. Windust.

A. W. Curton,

*H. G. Potter, J.P., F.S.I.

(Mayor),

* denotes Member present.

1.—REQUISITIONS:

The following requisitions were submitted and approved:—

	£	s.	d.
Works	1,169	11	2
Fire Brigade	452	1	9

2.—STAFF INCREMENTS:

The Committee have received a report with regard to increments due according to scale to members of the fire brigade staff.

RESOLVED TO RECOMMEND—That such increments be granted as from the appropriate dates.

[Having considered the matter in its financial bearing, the Finance and General Purposes Committee concur in the proposal.]

3.—STAFF SICKNESS:

A report was submitted with regard to the absence of three members of the fire brigade staff. **Noted.**

4.—TEMPORARY FIREMEN:

The Fire Superintendent reported that the following temporary firemen had been appointed. (W. & F.B.C., 24/4/39—5).

P. B. Nye	Central Fire Station.
E. A. Hunt	Central Fire Station
A. G. W. Matson	Central Fire Station
H. F. Allen	Mill Hill Fire Station.

5.—NATIONAL FIRE BRIGADE ASSOCIATION:

A letter was received from the above Association inviting the Council to send members of the Fire Brigade staff to attend the Firemen's Camp at Colwyn Bay from the 8th to the 14th July next.

The Camp is primarily organised for the training of Brigade members and provides instruction and practical demonstrations with fire appliances. Special lectures on fire fighting are also given.

RESOLVED TO RECOMMEND—That the Junior Sub-Officer from each Station, viz., Sub-Officer R. T. Ford, Central Fire Station, and Sub-Officer A. W. Mowlam, Mill Hill Fire Station, be appointed to attend the Firemen's Camp at Colwyn Bay from the 8th to the 14th July, 1939.

[Having considered the matter in its financial bearing, the Finance and General Purposes Committee concur in the proposal.]

6.—LONDON PROFESSIONAL FIRE OFFICERS BOARD:

The Committee gave further consideration to the question of granting an honorarium to Fire Superintendent R. Cook (referred back by the Council, W. & F.B.C., 24/4/39—7) in respect of his additional duties and responsibilities in connection with the Auxiliary Fire Services and see no reason to depart from their previous recommendation in the matter in the following terms:—

“That subject to the approval of the Home Office an honorarium of £50 be granted to Fire Superintendent R. Cook in connection with the Auxiliary Fire Services of the Borough, such honorarium to cover the period ending 31st May, 1939, and subject to adjustment.”

[Having considered the matter in its financial bearing, the Finance and General Purposes Committee concur in the proposal.]

7.—FIRE BRIGADE SYSTEMS OF DUTY:

As instructed by the Committee (W. & F.B.C., 24/4/39—6), a questionnaire was issued to each member of the Brigade regarding the above. The following are the questions as set out, together with the number of men voting for each:—

	Under present conditions of accommodation.	Assuming adequate and proper married and single quarters are provided.
1. Are you in favour of the present system of duty, bearing in mind that you are receiving in addition to the L.C.C. scale of pay, free quarters and light?	—	—
2. Are you in favour of the continuous duty system with one day leave in four and week-end leave every fourth week with free quarters and light and L.C.C. scale of pay?	1	16
3. Are you in favour of the stand-by system of duty (which provides that in each three days, duty, stand-by, and leave periods, will amount to 24 hours each) with free quarters, light and L.C.C. scale of pay?	—	—
4. Are you in favour of the two-platoon system with L.C.C. scale of pay and 10/- rent allowance, such rent allowance to be in the place of free quarters and light?		
		20

With two exceptions, all the men having married quarters are in favour of the continuous duty system of one day leave in four with week-end leave, while all the men living in single quarters are in favour of the two-platoon system.

The Borough Treasurer also submitted the following information as to service conditions under the varying systems of duty:—

FIRE BRIGADE SERVICE CONDITIONS.

	SYSTEM NO. 1.	SYSTEM NO. 2.	SYSTEM NO. 3.	SYSTEM NO. 4.	SYSTEM NO. 5.
PERSONNEL	<p>Present</p> <p>Continuous Duty System (Leave 1 day in 5).</p> <p>Superintendent 1 Station Officers 2 Sub-Officers 4 Firemen 34 <hr/>41</p>	<p>Present</p> <p>Continuous Duty System (Leave 1 day in 4 and week-ends).</p> <p>Superintendent 1 Station Officers 2 Sub-Officers 4 Firemen 34 <hr/>41</p>	<p>Stand By System.</p> <p>Superintendent 1 Station Officers 2 Sub-Officers 4 Firemen 34 <hr/>41</p>	<p>Two-Platoon System (Existing Stations).</p> <p>Superintendent 1 Station Officers 2 Sub-Officers 4 Firemen 34 <hr/>41</p>	<p>Two-Platoon System (Hendon Way and Mill Hill Stations).</p> <p>Superintendent 1 Station Officers 2 Sub-Officers 4 Firemen 34 <hr/>41</p>
QUARTERS	<p>Quarters in or adjacent to Fire Stations provided free for all ranks.</p>	<p>Same as System No. 1. (Accommodation or rent allowances to provide for 8 extra Men.)</p>	<p>Same as System No. 1. (Accommodation or rent allowances to provide for 2 additional Sub-Officers and 11 additional Men.)</p>	<p>Quarters provided free for Superintendent and Station Officers. Other ranks provide own accommodation. Rent allowances made as follows:— Sub-Officers 11/- p.w. Firemen 10/- p.w.</p>	<p>Same as System No. 4.</p>
DUTY ARRANGEMENTS	<p>Officers and Men on continuous duty either working or standing-by (subject to leave arrangements).</p>	<p>Same as System No. 1.</p>	<p>Men are on "Duty" for 6 hours and "Standing-By" for 6 hours alternately, for a continuous period of 48 hours. This is followed by 24 hours leave.</p>	<p>Sub-Officers and Firemen work in 2 shifts, a 9 hours day shift and a 15 hours night shift alternating week and week about.</p>	<p>Same as System No. 4.</p>
LEAVE ARRANGEMENTS	<p>Day leave—1 day in 5 Week-end leave—Nil Annual leave:— Station Officers, 18 days Other ranks, 14 days</p>	<p>Day leave 1 day in 4 Week-end leave—Nil Annual leave:— Station Officers, 18 days Other ranks, 14 days</p>	<p>Day leave—1 day in 3. Week-end leave—Nil Annual leave:— Station Officers, 18 days Other ranks, 14 days</p>	<p>Day leave—1 day in 7 Week-end leave—every 7th week Annual leave:— Station Officers, 18 days Other ranks, 14 days</p>	<p>Same as System No. 4.</p>
ANNUAL COST	<p>Wages (including Superannuation) 9256 Quarters (including allowances) 1175 <hr/>£10431</p>	<p>£ 10610 1383 <hr/>£11993</p>	<p>£ 11637 1518 <hr/>£13155</p>	<p>£ 16545 2083 <hr/>£18628</p>	<p>£ 17720 2413 <hr/>£20142</p>

Having carefully considered the matter in its various aspects, the Committee
RESOLVED TO RECOMMEND—

- (1) **That the continuous duty system (No. 2) with one day leave in four and week-end leave be approved in principle.**
- (2) **That the Borough Surveyor be instructed to submit a report on the question of accommodation for eight additional firemen (four to each of the two Fire Stations).**

[Having considered the matter in its financial bearing, the Finance and General Purposes Committee concur in the proposal.]

8.—MR. R. E. STIMPSON:

A letter addressed to His Worship the Mayor was received from Mr. R. E. Stimpson asking permission to appear before a meeting of the Council in order to state the facts of his case.

In view of consideration which has already been given in this case the Committee feel that no useful purpose would be served by the proposed interview.

9.—FACTORIES ACT, 1937:

Inspections have been carried out under the above Act at the following premises:—

- Witton-James Ltd., The Hyde, N.W. 9.
- E. H. Jones (Machine Tools) Ltd., The Hyde, N.W. 9.
- W. L. & R. Dawson, Nant Road, N.W. 2.
- The Tilley Lamp Co., Brent Street, N.W. 4.

RESOLVED TO RECOMMEND—That certificates as to means of escape in case of fire be approved in respect of such premises.

10.—FIRE HYDRANTS:

It was reported that two fire hydrants had been fixed in Harrowes Meade, Edgware.
Noted.

11.—INSPECTION OF APPLIANCES:

A recent inspection of fire appliances in the buildings enumerated in the report of the Fire Superintendent has been undertaken and the appliances found to be in order.
Noted.

12.—FIRE DRILL INSTRUCTION:

Since the last meeting of the Committee (24/4/39) fire drill instruction has been given by the Brigade at the following places:—

- John Groom's Crippleage.
- The North Middlesex Gas Company.
- Everett, Edgecumbe & Co., Ltd.

Noted.

13.—INSTALLATION OF SPRINKLER:

The Fire Superintendent reported that the skelton "Grinnell" sprinkler offered by Messrs. Mather & Pratt (W. & F.B.C., 21/11/38—18) has now been installed at the Central Fire Station. **Noted.**

14.—FIRE BRIGADE OPEN DAY:

The Fire Superintendent reported that approximately 2,000 people visited the Central and Mill Hill Stations whilst they were open to the public on Saturday, 20th May (W. & F.B.C., 24/4/39—16), and great interest was shown in the appliances and in the demonstrations carried out by the Fire Brigade Staff and the Auxiliary Fire Service. **Noted.**

15.—TALBOT AMBULANCE:

The Fire Superintendent submitted a report upon the accident in which the Talbot Ambulance (No. B.M.L. 945) had been involved. **Noted.**

16.—FIRE AND AMBULANCE SERVICES:

The following is a statement of fire and ambulance calls received during the month of April:—

Fire Calls.		Ambulance Calls.	
Fire Calls	18	Private	108
Malicious False Alarms	2	Private for Finchley	1
	20	Private for Council's Midwives	8
		Accidents	58
		Malicious Calls	1
		Not required, etc.	11
			187
			Noted.

AIR RAID PRECAUTIONS—AUXILIARY FIRE SERVICE.

17.—ENROLMENTS:

It was reported that during the past week 174 auxiliary firemen were presented with efficiency badges and certificates. At the present time 214 auxiliaries have completed their training and the remaining 255 commence training this week.

18.—DEMONSTRATION:

A report was submitted on the demonstration of a trailer pump with a crew of seven auxiliary firemen forming part of the Borough's Air Raid Precautions Services which were inspected by the public at the Hendon Aerodrome on Saturday last. **Noted.**

19.—TRAINING AND SOCIAL HUT—FENELLA:

The following quotations were submitted for the construction of a timber framed building (60 ft. x 20 ft.) to serve as a training and social centre at the rear of "Fenella":—

	£	s.	d.
H. Darby & Son, 71, Lea Bridge Road, Leyton, E. 10	722	0	0
W. Richards & Sons (Hendon) Ltd., Church Road, Hendon	634	10	0
E. S. Moss, Ltd., 159, Brent Street, Hendon	580	0	0
Buckingham & Sons Ltd., 45, Vivian Avenue, Hendon	535	0	0
H. Pickrill, 8, Station Buildings, Wealdstone	535	0	0

The amount of the lowest tender is greater than was anticipated. £95 was included for provisional and contingent sums and it would appear convenient to reduce this amount to £65 thereby reducing the lowest quotation to £505.

RESOLVED TO RECOMMEND—

- (1) That subject to the approval of the Home Office and to the usual financial enquiries the lowest tender, amounting to £505 be accepted.
- (2) That the Corporate Seal be affixed to any necessary documents.

Amendment

Before detailed consideration of the motion, the Finance and General Purposes Committee in concurring in the proposal, Recommend—That the following words be inserted after the word "tender":—
"that of Mr. H. Pickrill."

20.—EQUIPMENT:

The Committee have instructed the Borough Surveyor to submit a report on the provision of accommodation for Auxiliary Fire Service equipment at suitable centres in each of the three divisions.

21.—“FENELLA,” THE BURROUGHS:

The Borough Surveyor reported that the alterations to “Fenella” had been completed and that the firemen from “Ravensfield” were now in occupation of two rooms for sleeping quarters.

Satisfactory progress is also being made with the conversion of the outbuilding for sanitary accommodation in connection with the Auxiliary Fire Service. **Noted.**

22.—REDHILL HOSPITAL AND INSTITUTION:

The Fire Superintendent reported that at the request of the Middlesex County Council he had inspected and reported on the fire protection of the above premises in connection with Air Raid Precautions.

The County Council desire to have direct communication from the Redhill Hospital and Institution to the Mill Hill Fire Station and it has been suggested that a Gamewell Fire Alarm Box should be installed in each building.

RESOLVED TO RECOMMEND—That Gamewell Fire Alarms be installed in the Redhill Hospital and the Institution, subject to an annual rental for the installation to cover all costs to the Town Council being paid by the Middlesex County Council.

Amendment

Before detailed consideration of the matter, the Finance and General Purposes Committee Recommend—That the following be inserted after the word “rental” :—

“ of £15.”

23.—PUBLIC TELEPHONE KIOSK—TOWN HALL:

The Committee have given further consideration to the question of the installation of two public telephone kiosks in the Town Hall, referred back by the Council on the 8th May (W. & F.B.C., 24/4/39—23), and have

RESOLVED TO RECOMMEND—That no further action be taken in the matter at the present time.

SWIMMING POOLS.

24.—CHARGES FOR ADMISSION:

A letter was received from the Juvenile Organisations Committee referring to the Council's decision to make no reduction in the charge for admission to the swimming baths for affiliated organisations (W. & F.B.C., 13/2/39—23), and suggesting a deputation from the Executive Committee be received.

RESOLVED—That a deputation from the Executive Committee of the Juvenile Organisations Committee be received at the next meeting.

25.—WEST HENDON:

An application was received from the Hendon Schools' Swimming Association for the use of the West Hendon Swimming Pool during the evening of the 4th July in order to hold the preliminary heats, and annual gala on the 20th July.

RESOLVED TO RECOMMEND—That the application of the Hendon Schools' Swimming Association be approved subject to any expenditure incurred being charged to the Education Account.

[Having considered the matter in its financial bearing, the Finance and General Purposes Committee concur in the proposal.]

26.—REPAIRS TO PROPERTIES:

It was reported that 93 requisitions have been dealt with since the last meeting of the Committee and works at Mill Hill Swimming Pool and Moat Mount Open Space are nearing completion. **Noted.**

Report on the
le centres in

d been con-
of two rooms

thbuilding for
oted.

lesex County
e premises in

hill Hospital
that a Game-

stalled in the
or the installa-
dlesex County

e and General
inserted after the

he installation
Council on the

in the matter

ferring to the
the swimming
ing a deputa-

the Juvenile

association for
n July in order

Report of the Libraries and Local Pensions Committee.

22nd May, 1939.

COMMITTEE:

*Councillor P. Lightfoot (*Chairman*).

Aldermen:

*W. M. Maughan, J.P.,

*R. A. B. Teare, M.B.E.

Councillors:

*T. K. Bridge,

*C. Pinkney,

G. R. Richardson,

*E. J. Cox,

*G. J. Pryke, F.I.A.C.,

*T. J. Scott,

*F. W. Gilpin,

A.M.I.S.E.,

(Mrs.) M. Thomas.

* denotes Member present.

Part I.—Old Age Pensions.

1.—CLAIMS, ETC.:

The Committee considered fifteen claims and two questions. The details of each case and the Committee's decision thereon are recorded in the Local Pension Minute Book.

Part II.—Libraries.

2.—REQUISITIONS:

Requisitions amounting to £485 3s. 2d. were submitted and approved.

3.—BOOK SELECTION SUB-COMMITTEE:

The following report was submitted:

22nd May, 1939.

SUB-COMMITTEE:

*Councillor P. Lightfoot (*Chairman*).

Alderman:

*R. A. B. Teare, M.B.E.

Councillors:

(Mrs.) M. Thomas,

G. R. Richardson,

T. J. Scott.

* denotes Member present.

PURCHASE OF BOOKS—ADDITIONS TO STOCK:

The Sub-Committee considered lists comprising 165 recent and standard books suggested for addition to the stock at the Central Library at an estimated cost of £55, 160 volumes for addition to the stock of the Golders Green Branch Library at an estimated cost of £53, and 171 volumes at an estimated cost of £46 for addition to the stock of the Mill Hill Branch Library.

The Sub-Committee

RECOMMEND—That the Chief Librarian be authorised to purchase the books included in the lists submitted.

RESOLVED TO RECOMMEND—That the report of the Sub-Committee be approved and adopted.

4.—HENDON TECHNICAL INSTITUTE:

The Chief Librarian reported that with the opening of the new Technical Institute at Church End, an increasing number of the students are likely to make use of the Central Library, as it is understood that the Institute Library will be confined to highly specialised books, chiefly of a reference character such as are not normally provided by a Public Library.

The existing rule applicable to these students provides as follows:—

Other residents, non-resident employers or employees working in the Borough, and persons attending educational institutions in the Borough, if over 14 years of age, may become borrowers on signing the necessary application form and furnishing a guarantee from a Local Government Elector whose liability shall not exceed the sum of Two Pounds.

A number of membership forms signed by the Principal have already been presented, and the Chief Librarian is of opinion that the Principal should not be held financially responsible for defaulters. It was pointed out that a large number of Public Libraries permit Head Teachers to recommend pupils as borrowers without the Teachers incurring any liability, and the following amended rule was submitted:—

Other residents, and non-resident employers or employees working in Hendon, may become borrowers on signing the necessary application form and furnishing a guarantee from a Local Government Elector whose liability shall not exceed the sum of Two Pounds. Persons attending an educational institution in the Borough may also become borrowers on the recommendation of the Principal or Head Teacher, but such recommendation shall not carry with it any liability.

RESOLVED TO RECOMMEND—That the suggested amended rule be approved and adopted.

[Having considered the matter in its financial bearing, the Finance and General Purposes Committee concur in the proposal.]

5.—STAFF—MILITARY SERVICE:

The Chief Librarian reported that within the next twelve months two assistants are to be called up for service in the Militia, and another will be affected by the Reserve and Auxiliary Forces Bill.

RESOLVED TO RECOMMEND—That authority be given to engage the necessary temporary assistance as and when required.

Amendment

Before detailed consideration of the matter, the Finance and General Purposes Committee Recommend—That the above recommendation be deleted and the following substituted:—

“That the attention of the Libraries Committee be drawn to Item No. 12 of the Finance and General Purposes Committee Report (12/6/39) as to the engagement of temporary employees necessitated by the calling up of members of the permanent staff for Military Service.”

6.—GOLDERS GREEN BRANCH LIBRARY:

On the report of the Chief Librarian,

RESOLVED TO RECOMMEND—That authority be given for the closing of the above Library from Monday, July 31st to Saturday, August 12th inclusive, for the purpose of re-decorations.

7.—NATIONAL SERVICE:

The Chief Librarian reported that he had applied for enrolment in the Civilian Observer Corps. **Noted and approved.**

Report of the Housing Committee.

22nd May, 1939.

COMMITTEE:

*Councillor F. W. Cilpin (*Chairman*).

Aldermen:

*W. M. Maughan, J.P.,

*R. A. B. Teare, M.B.E.

Councillors:

*T. K. Bridge,

*C. Pinkney,

*G. R. Richardson,

*E. J. Cox,

*G. J. Pryke, F.I.A.C.,

*T. J. Scott,

*P. Lightfoot,

A.M.I.S.E.,

(Mrs.) M. Thomas.

* denotes Member present.

TENANCIES.

1.—TRANSFERS—APPLICATIONS:

The Housing Manager reported the following applications:—

Application

No.

3511	From a 2 to a 3-bedroom type house at Child's Hill.
5206	From a 2-bedroom type house at Reets Farm to a larger house.
5995	From a 3-bedroom parlour type house at Brent Hill to a 3-bedroom non-parlour type.
3705	From a 3-bedroom type house to a 3-bedroom parlour type at Brent Hill.
6238	From a 3-bedroom parlour type house to a 3-bedroom non-parlour type at Brent Hill or The Hyde.

RESOLVED—That the applications be approved and transfers effected when suitable accommodation is available.

2.—TRANSFERS—ARRANGED:

The Housing Manager reported that transfers had been arranged as follows:—

Appln.

No.	Name.	From.	To.
5869	Walton, Mrs. A.	19, Sturgess Avenue	56, Park Road.
4934	Eggins, F.	57, Clitterhouse Road	48, Clitterhouse Crescent.
4172	Clements, H.	118, Clitterhouse Road	57, Clitterhouse Road.
3583	Benham, G.	81, Goldsmith Avenue	44, Goldsmith Avenue.
5167a	McCarthy, F. W.	57, Claremont Road	59, Claremont Road.
4346	Biggs, A. J.	70, Clitterhouse Crescent	19, Sturgess Avenue.

Noted.

LODGERS.

3.—TENANT NO. 3966:

The Committee received a report from the Housing Manager with regard to the above Tenant who occupies a 2-bedroom type house at Clitterhouse.

RESOLVED TO RECOMMEND—That the lodger be required to vacate the premises within 14 days, failing which a notice to quit be served on the Tenant.

4.—TENANT NO. 3526:

The above Tenant seeks permission for his mother (Aged 70) to reside with him at Cloister Road.

RESOLVED TO RECOMMEND—That the request be granted.

5.—TENANT NO. 3893:

The Committee considered the circumstances in this case and have instructed the Housing Manager to submit a further report thereon at the next meeting.

6.—ARREARS OF RENT:

The following tenants were reported to be four weeks or more in arrear:—

1196	6483	6247	3893
2675	2807	2536	5565
3220	5797	6276	5357
4701	5155	4311	5358
6271	3080	5119	4417

With regard to the undermentioned, the position is as follows:—

2536	}	Payment of rent still being made, and a sum weekly off arrears.
4311		
5119		
3893		
5358		
4417		Will be interviewed by the Chairman of the Committee.
5357		Payment of rent will be maintained and a sum weekly off arrears.

RESOLVED TO RECOMMEND—

- (1) **That a further report be presented with regard to Tenants Nos. 1196, 2675, 2807, 6247, 5565, 6271 and 6276.**

(In the last case the report to be presented at the expiration of a period of three months).

- (2) **That a notice to quit be served on Tenants Nos. 3220, 4701, 5797, 5155 and 3080.**

(A further decision with regard to Case No. 4701 is recorded in MIS in the Committee Minute Book).

- (3) **That failing a payment of 2/- weekly off the arrears (Tenant No. 6483) a notice to quit be served.**

7.—HOUSING APPLICATIONS:

The following is a summary in connection with a list of new applications:—

Urgent A.1	----	----	----	----	----	----	----	3
List 1	----	----	----	----	----	----	----	9
List 2	----	----	----	----	----	----	----	5
								17

Noted.

OVERCROWDING.**8.—HENDON COUNCIL ESTATES:**

The Annual survey previously referred to is progressing and it is hoped to report thereon at the next meeting.

A report was submitted with regard to Tenant No. 1055 and instructions were given to the Housing Manager.

9.—WATLING ESTATE:

The outstanding applications now number 4 of which 1 has declined the tenancy of a Hendon Council House. **Noted.**

10.—ANNUAL GARDENS COMPETITION:

The Housing Manager reported that it was proposed to make arrangements for the Federation of Middlesex Horticultural and Allotment Societies to undertake the judging during the latter part of July.

In the past it has been the practice in connection with the preliminary judging to inspect every garden on the Council's Housing Estates, the final judging being then undertaken in respect of gardens of a certain standard.

Many tenants, despite the fact that they possess well kept gardens, do not desire to enter the competition, and in order to relieve the judges of unnecessary work it is intended that they shall only be asked to inspect gardens actually entered in the competition. **Noted and approved.**

11.—DOLE STREET ESTATE:

A communication was reported from the London Passenger Transport Board in reply to the Council's representation (Hg.C., 16/1/39—11) for improved omnibus facilities to serve the above Estate.

The Board intimate that a comprehensive survey of the area in question has been made to assist in estimating the transport requirements now and in the future, such survey indicating that the time is not yet ripe for the provision of new transport facilities. It was stated that the Council's Housing Estate would not in itself justify a bus service, and further that the pedestrian movement to and from the Paddington Borough Council's Cemetery has been taken into consideration but has very little bearing upon the position. The Board state, however, that the area will be kept under observation for further developments.

Apart from the Council's Housing Estate, there is considerable development in the area, and the Committee have

RESOLVED TO RECOMMEND—That the London Passenger Transport Board be asked to re-consider the matter with a view to improved facilities being provided at an early date.

Report of the Buildings and Town Planning Committee.

22nd May, 1939.

COMMITTEE:

*Councillor G. H. Hignett (*Chairman*).

Aldermen:

W. R. Clemens, F.C.A.,
*J. J. Copestake, J.P.,

S. H. Egan, J.P.
(*Deputy Mayor*),

B. Flowers,

Councillors:

*E. Arter, M.C., M.I.A.E.,
*F. H. Bate,
*J. Griffiths,

W. A. Hicks,
L. Hirshfield,
*T. Pugh,

*W. H. N. Shakespeare,
M.C., A.F.C., J.P.,
*H. P. Small.

* denotes Member present.

HENDON PLANNING SCHEME NO. 1.

1.—ADVERTISEMENT HOARDING—JUNCTION OF BRIDGE LANE WITH NORTH CIRCULAR ROAD:

An application was considered from Solosigns Ltd., for consent to erect an advertisement hoarding at the above junction. The proposed hoarding is "V" shaped, each portion being 25 feet long, and 17 feet above ground level. The site is in a residential zone of the Hendon Planning Scheme No. 1.

RESOLVED—That consent be refused (Clause 51).

2.—KENNYLAND COURT, HENDON WAY, HENDON:

The Borough Surveyor reported on an application from Mr. C. M. Maltby for consent to convert into flats eight shops, forming part of the above building, which consists of shops with flats over. The permissible maximum density of development under Scheme No. 1 has already been allowed in respect of this site, and if the conversion were permitted the windows of the proposed flats would be in line with the back of the footpath of Hendon Way.

RESOLVED—That consent be refused (Clauses 35 and 36).

3.—22, MANOR PARK CRESCENT, EDGWARE:

This is an application from Mr. D. Myers for consent to erect an addition to the above premises situate at the junction of Manor Park Crescent with Manor Park Gardens, such addition to be used for office purposes. The application has been advertised in compliance with Clause 30 of the Hendon Planning Scheme No. 1 and thirty-eight objections from residents in the vicinity have been received. Having regard to the adjacent residential property and the objections received, the Committee

RESOLVED—That consent be refused (Clause 28).

4.—COMMUNICATING STREET FROM ENGEL PARK TO WENTWORTH HALL ESTATE, MILL HILL:

The Council on the 3rd May, 1937 (B. & T.P.C., 19/4/37) in dealing with building application No. A.6361 fixed the site of a communicating street under Clause 18 of the Scheme upon neighbouring land to secure due co-ordination of development. A claim

for compensation was submitted on behalf of Park Estates Ltd. and referred to the District Valuer (B. & T.P.C., 13/2/39—11). . A settlement in the matter has now been effected by agreement to purchase the site of the communicating street for the sum of £201 12s. 0d.

RESOLVED TO RECOMMEND—

- (1) **That the terms of settlement be approved.**
- (2) **That the Corporation take a conveyance of the land at a purchase price of £201 12s. 0d. and undertake to pay the reasonable costs of the Vendors' Solicitors and Surveyors.**
- (3) **That the Corporate Seal be affixed to any necessary documents.**
- (4) **That the Council declare pursuant to Clause 18 (7) of the Hendon Planning Scheme No. 1 that the communicating street shall, when declared to be a street, become a private street, and that any necessary notices to this effect be served.**

[Having considered the matter in its financial bearing, the Finance and General Purposes Committee concur in the proposal.]

HENDON PLANNING SCHEME NO. 2

5.—LAND—FINCHLEY ROAD, GOLDERS GREEN:

The Borough Surveyor reported on an application from Messrs. Anderson, Forster, Warren & Wilcox for permission to construct a block of 24 large flats on the site of the house known as "Helenslea," Finchley Road, Golders Green. Having regard to the proposed density of development, height of buildings, and the character of the surrounding property, the Committee

RESOLVED—That the application be disapproved under the Hendon Planning Scheme No. 2, and under the Restriction of Ribbon Development Act, 1935.

6.—MIDDLESEX COUNTY COUNCIL (GENERAL POWERS) ACT, 1938:

The Borough Surveyor submitted a report in connection with the reference from the Public Health and Medical Services Committee (6/3/39—16) relative to the user of the under-mentioned premises in relation to the Hendon Planning Schemes, such premises having been registered under Section 71 of the above Act for the storage and/or sale of food.

No. 12, Ravenshurst Garages, Babington Road, Hendon, is one of seventeen garages approved by the Council in 1924, the application being described as "Private Lock-up Garages." The property is situate within a special residential area of the Hendon Planning Scheme No. 2 and its use as a food store will constitute a contravention of the Scheme.

With regard to the temporary shed at the rear of No. 18, Annesley Avenue, Hendon, this property is situate within a general zone of the Hendon Planning Scheme No. 1 and its use as a store is not prohibited under the Scheme.

The position under the Act of 1938 is that the Council can refuse to register premises or revoke registration if they are satisfied that the public health is or is likely to be endangered or that the premises are not suitable, but it does not appear that registration could be refused solely on town planning grounds. A right of appeal against refusal of registration or revocation of registration, exists under Section 71 of the Act of 1938.

RESOLVED TO RECOMMEND—That the Public Health and Medical Services Committee be informed:—

- (1) That the use of No. 12, Ravenshurst Carages, Babington Road for the storage of food is not in accordance with the provisions of the Hendon Planning Scheme No. 2, and
- (2) That having regard to the temporary character of the shed at 18, Annesley Avenue, it is undesirable that the shed should be used for the storage of food.

7.—SITES FOR TERRITORIAL ARMY ASSOCIATIONS:

The Town Clerk reported the receipt of Circular 1821 from the Ministry of Health urging Local Authorities to assist County Territorial Associations in securing sites for additional accommodation for recruiting and training.

In view of the special urgency for the acquisition of this additional accommodation for the Territorial Army lengthy discussion of the merits of alternative sites will not be possible. County Territorial Associations will be advised to emphasize this urgency and to ask that their application for help in finding a site should be answered within fourteen days, failing which they should proceed to find a site themselves in which case, of course, planning considerations would be secondary. The sites required will vary in area from half-an-acre for small detachments to four or five acres for the larger and more technical units.

The Minister feels sure that the responsible authorities will do what they can to meet the needs of the expanding Territorial Army and will gladly avail themselves of these proposals for consultation, which are designed to enable due weight to be given to planning considerations.

It is suggested that to this end the Chairman of the Planning Committee, with the Clerk and the Planning Officer, should be authorised to negotiate with the representatives of the Territorial Army Association.

RESOLVED TO RECOMMEND—That in the event of applications being received, the Chairman, together with the Town Clerk and the Borough Surveyor, be authorised to negotiate with the representatives of the County Territorial Association.

8.—BUILDING APPLICATIONS:

(A) The following applications were in order on submission and have been accordingly approved as indicated:—

Appln. No.	Description and Situation.	Public Health Act, 1936.	Town Planning.	Restriction of Ribbon Development Act, 1935.
A.5014	Garage, north-east side, Edgware Road, N.W. 2. Owner and Applicant—Shell-Mex & B.P. Ltd.	Approval already given		
				Approved.
				Conditions:—
				(1) That the building shall be erected in the position indicated on the plan deposited on the 1st April, 1939
				(2) That the accesses constructed under this consent shall be temporary and as an when development takes place to the north and/or south of the applicant's frontage thereby providing alternative access to the trunk road by means of a service or estate road, the said accesses constructed under this consent shall thereupon be closed provided the alternative accesses are not more than 440 yards from the applicant's frontage
				(3) That before the temporary means of access are constructed, formed or laid out the applicant shall submit to the Hendon Borough Council a plan showing the position, width, gradient and mode of construction of crossings extending from the said temporary means

Appl. No.	Description and Situation.	Public Health Act, 1936.	Town Planning.	Restriction of Ribbon Development Act, 1935.
A.8052	Air raid shelter, 2, Park Drive, N.W.11. Owner—Mrs. Spence. Applicant—F. Dymock Ltd.	Approved	Approved (Scheme 2) Interim Development Order:— That the work shall be actively commenced within twelve months of the date of this Order	of access to the carriage-way of the trunk road and they shall construct such crossings at their own expense and to the satisfaction of the Hendon Borough Council in accordance with the plan as submitted or required by the Hendon Borough Council to be amended.
A.8053	Air raid shelter, 6, Beaufort Gardens, Hendon. Applicant—Garsubil Ltd.	Approved	—	—
A.8054	Air raid shelter, 16, Stoneyfields Lane, Edgware. Applicant—Garsubil Ltd.	Approved	—	—
A.8055	Alterations and additions, 65, Brampton Grove, Hendon. Owner—B. Clark. Applicant—L. C. Norton	Approved	—	—
A.8057	Garage, 50, Gibbs Green, Edgware. Owner—L. D. Goodall. Applicant—J. Childs & Son Ltd.	Approved	—	—
A.8058	Air raid shelter, 235, West Heath Road, N.W.11. Owner—J. Coleman. Applicant—F. Dymock Ltd.	Approved	—	—
A.8059	Air raid shelter, 233, West Heath Road, N.W.11. Applicant—F. Troy & Co.	Approved	—	—
A.8060	Air raid shelter, 36, Woodstock Road, N.W.11. Applicant—F. Troy & Co.	Approved	Approved (Scheme 2) Interim Development Order:— That the work shall be actively commenced within twelve months of the date of this Order	Approved.

Appl. No.	Description and Situation.	Public Health Act, 1936.	Town Planning.	Restriction of Ribbon Development Act, 1935.
A.S061	Air raid shelter, 166, Golders Green Road, N.W. 11. Applicant—S. Marshall	Approved	—	Approved.
A.S027	Bay window, 81, Annesley Avenue, N.W. 9. Owner—G. Winkworth. Applicant—Anton & Co.	Approved	—	—
A.S045	Alterations to garage, "The Cedars," Mill Ridge, Edgware. Owner—Mr. Lajus. Applicant—H. Ruthven	Approved	—	—
A.S048	Garage, 79, Booth Road, N.W. 9. Owner and Applicant—A. E. Parker	Approved	—	—
A.S051	Air raid shelter, north side, Colindale Avenue, N.W. 9. Owner—E. H. Jones, Ltd. Applicant—Anti Bomb Constructions Ltd.	Approved.	—	—
A.S064	Garage, 37, Flower Lane, Mill Hill. Owner and Applicant—C. W. Cannell	Approved.	—	—
A.S066	Air raid shelter, 11, Weymouth Avenue, Mill Hill. Owner—Dr. E. A. Evans. Applicant—E. L. Saunders	Approved.	—	—
A.S067	Air raid shelter, 9, Hocroft Road, N.W. 2. Applicant—Anti Bomb Constructions Ltd.	Approved	—	—
A.S070	Garage, 44, Edgwarebury Lane, Edgware. Owner and Applicant—A. W. Curton Ltd.	Approved	—	—
A.S071	Glass lean-to roof, 1, Sylvan Avenue, Mill Hill. Owner and Applicant—B. B. Wills	Approved	—	—
A.6963f	Bungalow, plot 36, Road "F," Wood Grange Estate, Edgware Way, Edgware. Owner—H. Newlyn. Applicant—Neasden Property Co.	Approved	Consent given (Clauses 23, 39 and 43 (3)) Condition:— That the distance between the north wall of the bungalow and the owner's north boundary shall not be less than three feet, and that the distance between the north wall of the bungalow and the south wall of bungalow on plot 37 shall not be less than six feet	—

Appl. No.	Description and Situation.	Public Health Act, 1936.	Town Planning.	Restriction of Ribbon Development Act, 1935.
A.8041	Amended plan of garage, 22, Broadhurst Avenue, Edgware. Owner—A. G. F. Cartwright. Applicant—W. E. Pearce & Son	Approved	—	—
A.8068	Addition, 1, The Welches, Milesplit Hill, Mill Hill. Owner and Applicant—O. Grimsdell	Approved	Consent given (Clause 43 (3)) Condition:— That the distance between the north wall of the addition and the owner's north boundary shall not be less than three feet	—
A.8076	Air raid shelter, east side, Edgware Road, N.W.9. Owner—Duple Bodies & Motors Ltd. Applicant—Dudley G. Marsh	Approved	—	Approval incorporating Ministry of Transport's conditions.
A.8079	Air raid shelter, south side, Bunns Lane, Mill Hill. Owner and Applicant—John Laing & Son Ltd.	Approved	Consent given (Clause 28)	—
A.8080	18 houses and garages, 56-78 and 53-63, Worcester Crescent, Mill Hill. Owner and Applicant—G. Wimpey and Co. Ltd.	Approved	Consent given (Clause 43 (3)) Condition:— That the distance between the flank wall of each house on plots 60, 61, 62, 63, 68, 70, 76 and 78 and each owner's side boundary shall not be less than three feet	—
A.8081	House and garage, north-west side, Hendon Wood Lane, Mill Hill. Owner—E. U. Spruce. Applicant—R. C. Hayes	Approved	Consent given (Clause 43 (3)) Condition:— That the distance between a portion of the north-west wall and the owner's north-west boundary shall not be less than three feet, and that the distance between a portion of the south-east wall and the owner's south-east boundary shall not be less than two feet three inches	Approved. Conditions:— (1) That the owner will dedicate the land required to form the second carriage-way along this length of Hendon Wood Lane (2) That the owner will lay out the second roadway to have a twenty feet carriage-way and a ten feet footpath with suitable connections at each end to the existing road in accordance with plans and sections contained in Application No. A.6112.

Appl. No.	Description and Situation.	Public Health Act, 1936.	Town Planning.	Restriction of Ribbon Development Act, 1935.
A.8083	Air raid shelter, 9, Basing Hill, N.W.11. Applicant—Barkers	Approved	—	—
A.8084	Air raid shelter, 29, Manor Drive, N.W.7. Owner—E. W. Baker. Applicant—Horn & Co.	Approved	—	—
A.8085	New building and extension to existing building, south side, Hendon Way, N.W.4. Owner—Johnson and Sons Manufacturing Chemists Ltd. Applicant—Fraser & Turnbull	Approved	—	—
A.8086	Police control cabin, east side, Claremont Road, N.W.2. Owner and Applicant—Handley Page Ltd.	Approved	—	—
A.8087	Air raid shelter, north side, Burtonhole Lane, Mill Hill. Owner—Imperial Cancer Research Fund. Applicant—Lanchester, Lodge & Davis.	Approved	—	—
A.8090	Addition, 22, Watling Avenue, Burnt Oak. Owner—Harvey & Thompson Ltd. Applicant—Browett Taylor & Co.	Approved	Consent given (Clause 42 (ii)) Condition:— That the proportion of site which may be covered by buildings shall not exceed 93 per cent.	—
A.8094	Bay windows, 26, Manor Way, N.W.9. Owner—P. Wilkens. Applicant—F. E. Spence	Approved	—	—
A.8096	Alterations, 8, Turner Close, N.W.11. Owner—Prof. F. A. Von Hayen. Applicant—John C. S. Soutar	Approved	—	—
A.8097	Conversion of 120, Station Road, Hendon, into two flats. Owner and Applicant—Miss A. L. Linden	Approved	Approved (Scheme 2) Interim Development Order:— That the work shall be actively commenced within twelve months of the date of this Order	—
A.8098	5 air raid shelters, south side, Hendon Way, N.W.4. Owner—Johnson & Sons Manufacturing Chemists Ltd. Applicant—Fraser & Turnbull	Approved	Consent given (Clause 60) Condition:— That the Agreement, dated the 23rd May, 1932, between Johnson & Sons Ltd. and the Corporation shall be suitably endorsed	—

Appl. No.	Description and Situation.	Public Health Act, 1936.	Town Planning.	Restriction of Ribbons Development Act, 1955.
A.8099	Re-construction of garage, 21, Rudyard Grove, Mill Hill. Owner—Mrs. A. Rogers. Applicant—A. E. Rogers	Approved	—	—
A.8101	Addition and alterations, 51, Shirehall Park, Hendon. Owner—Mrs. Van Roggon. Applicant—W. Richards and Sons (Hendon) Ltd.	Approved	—	—
A.8103	Vestries, St. Margaret's Church, Station Road, Edgware. Owner—Rev. H. A. H. Len. Applicant—J. P. Blake	Approved	—	—
A.8010a	House, 67, Harrowes Meade, Edgware. Owner and Applicant—John Laing & Son Ltd.	Approved	—	—
A.7571b	53 garages, 1/3, Hale Lane, 7/14, Farm Road, 16/39, Road No. 1, 40/43 and 45/58, Road No. 2, Hale Farm Estate, Hale Lane, Edgware. (Plot numbers.) Owner—Aldersgate Estates Ltd. Applicant—W. F. G. Latter	Approved	—	Approved. Condition:— That crossings shall be constructed over the public footpath of Farm Road, and that three existing crossings over the public footpath of Farm Road and Hale Lane shall be removed or altered as required; the work to be carried out by the Council after a deposit has been paid by the applicant to cover the estimated cost.
A.8074	Air raid shelter, east side, Rookery Way, N.W.9. Owner—Spurling Motor Bodies Ltd. Applicant—Dudley G. Marsh	Approved	—	—
A.8077	Addition, "St. Augustine's," Ashley Lane, Hendon. Owner—Rev. C. Miller. Applicant—S. Taylor, Son and Platt	Approved	Consent given (Clause 28)	—
A.8107	Farm building and farmers' quarters, rear of St. Vincent's Convent, The Ridgeway, Mill Hill. Owner—Community of St. Vincent's Convent. Applicant—Emden Egan & Co.	Approved	—	—

Applications Considered.**(B).**

The following applications required special consideration and the Committee's decision is given in each case hereunder:—

Appl. No.	Description and Situation.	Public Health Act, 1936.	Town Planning.	Restriction of Ribbon Development Act, 1935.
A.5043g	Revised section of layout, Wood Grange Estate, Edgware Way, Edgware. Owner and Applicant—Neusden Property Co.	Approved	Consent given (Clause 43 (3)) Conditions:— (1) That the distance between the flank wall of each bungalow on plots Nos. 24, 25, 26, 27, 37, 62, 63 and 77, and each owner's side boundary may be less than 4 feet in accordance with the plan referred to (2) That Consent No. 450 is hereby cancelled	—
A.5026	Porter's lodge, Brentview House and Sheila House, North Circular Road, N.W.4. Owner—Plus Flats Management Ltd. Applicant—Murrell & Pigott	Approved	Consent given (Clause 36)	—
A.5029	Garage, 43, Greenfield Gardens, N.W.2. Owner—Mr. Rosekilly. Applicant—Sidney J. Cook	Approved	Consent given (Clause 46) Condition:— That the facing materials of the front and side walls of the garage shall match those on the existing house	—
A.5033	Store shop, west side, Bittacy Hill, Mill Hill. Owner and Applicant—North Middlesex Gas Co.	Approval already given	Consent given (Clauses 23, 28)	Approved.
A.5035	Additions, 9, Glendor Gardens, N.W.7. Britton. Applicant—W. F. Thorpe	Approved	Consent given (Clause 28)	—
A.5082	Addition, 29, Manor Drive, Mill Hill. Baker. Applicant—G. H. Wenyon	Approved	Consent given (Clause 43 (3)) Condition:— That the west wall of the addition may be erected up to the owner's west boundary	—

Appl. No.	Description and Situation.	Public Health Act, 1936.	Town Planning.	Restriction of Ribbon Development Act, 1935.
A.8089	3 air raid shelters, Rawplug Works, Hale Lane, Mill Hill. Owner and Applicant—Rawplug Co. Ltd.	Approved	Consent given (Clause 60) Condition:— That the Agreement, dated 31st December, 1929, between the Company and the Corporation shall be suitably endorsed	—

9.—TEMPORARY BUILDINGS:

Applications in Order.

The following applications for temporary buildings were in order on submission, and the Committee RECOMMEND—That such applications be approved for a period expiring on the 31st March, 1942:—

A.7971	Garage, 39, Meadow Gardens, Edgware. Owner and Applicant—T. Lawton	Approved.	—	—
A.8017	Garage, 58, Holders Hill Road, Hendon. Owner and Applicant—A. E. Manning	Approved.	—	Approved
A.8046	Garage, 22, Glenwood Road, Mill Hill. Owner and Applicant—F. C. Ashdown	Approved	—	—
A.8050	Garage, 81, Templars Avenue, N.W. 11. Owner and Applicant—C. Friend	Approved	Approved (Scheme 2) Interim Development Order:— That the work shall be actively commenced within twelve months of the date of this Order	Approved.
A.8056	Garage, 114, Rushgrove Avenue, N.W. 9. Owner and Applicant—L. F. Bird	Approved	—	—
A.8062	Garage, 45, Walmington Fold, N. 12. Owner and Applicant—Mrs. M. Law	Approved	—	—
A.8095	Garage, 46, Riverdene, Edgware. Owner and Applicant—A. Littler	Approved	—	—
A.7977	Garage, 105, Hale Drive, Mill Hill. Owner and Applicant—Miss E. Müller	Approved	—	—
A.8065	Garage, 4, Northolm, Edgware. Owner and Applicant—H. Richardson	Approved	—	—

Appl. No.	Description and Situation.	Public Health Act, 1936.	Town Planning.	Restriction of Ribbon Development Act, 1935.
A.S088	Lean-to garage, 5, Cleveland Gardens, N.W.2. Owner and Applicant—E. Adams	Approved	—	—
A.S092	Garage, 13, Osborne Gardens, Mill Hill. Owner and Applicant—M. Edwards	Approved	—	—
A.S093	Garage, 23, Florence Street, Hendon. Owner and Applicant—A. Ernster	Approved	—	Approved.
A.S102	Garage, 5, Langley Crescent, Edgware. Owner and Applicant—D. W. Stewart	Approved	—	—
A.S075	Garage, 84, Walmington Fold, N.12. Owner—Miss D. Perry and Miss M. Hunniford. Applicant — Miss D. Perry	Approved	—	—
(B) The following application for a temporary building was not in order on submission, and the Committee RECOMMEND—That such application be disapproved as indicated:—				
A.S069	Lock-up shop, north side, Brent Park Road, Hendon. Owner and Applicant—C. Dickinson	Disapproved (Byelaws 19 and 94)	—	—
(C) The following application for a temporary building required special consideration, and the Committee RECOMMEND—That such application be approved for a period expiring on the 31st March, 1942:—				
A.S049	Sports pavilion, south side, Cool Oak Lane, N.W.9. Owner and Applicant—Handley Page Ltd.	Approved Subject to the Pavilion being erected a minimum distance of fifteen feet from the southern boundary of Cool Oak Lane	—	—

10.—TEMPORARY CAR SHELTER—221, HALE LANE, EDGWARE:

The Borough Surveyor submitted a report with regard to the above temporary car shelter, which is situate within a residential area (Use Zone I) of the Hendon Planning Scheme No. 1. The Committee are of opinion that the shelter seriously injures the amenity of the neighbourhood within Use Zone I of the Scheme, and

RESOLVED TO RECOMMEND—That authority be given for the necessary action to be taken under the provisions of Clause 50 of the Hendon Planning Scheme No. 1, to abate the injury.

Report of the Rating and Valuation Committee.

13th June, 1939.

COMMITTEE:

*Councillor H. P. Small (*Chairman*).

Aldermen:

S. H. Egan, J.P.,
(*Deputy Mayor*),

B. Flowers.

Councillors:

*E. Arter, M.C., M.I.A.E.,
H. Connell, J.P.,

E. J. Cox,
*A. W. Curton,

W. A. Hicks,
*C. F. Windust.

* denotes Member present.

His Worship the Mayor (Councillor H. G. Potter, J.P., F.S.I.) was also present.

VALUATIONS.

1.—68th PROPOSAL LIST:

It was reported that this list was approved by the Central Middlesex Assessment Committee on the 19th May and resulted in a net increase of £2,183 (Hendon £1,384, Edgware £799). There were fourteen objections by Ratepayers to entries in the list, out of which three were withdrawn, the assessments proposed were confirmed in seven cases, one reduction made, in one case the decision was adjourned, in another case the hearing was deferred, and in the remaining case the entry was deleted from the list.

Noted.

2.—69th PROPOSAL LIST:

Valuation Sheets Nos. 1 to 7 were submitted containing assessments included in the above list, which comprises 91 entries (Hendon 66, Edgware 25). This list was deposited with the Central Middlesex Assessment Committee on the 7th instant and, subject to objections, will be approved on the 14th instant. The list discloses a provisional increase of rateable value of £2,168 (Hendon £1,800, Edgware £368).

RESOLVED—That the assessments contained in Valuation Sheets Nos. 1 to 7 be approved and signed.

3.—70th PROPOSAL LIST:

Valuation Sheets Nos. 1 to 8 were submitted containing assessments for inclusion in the above list. The last date for forwarding statutory notices in connection with this list is the 4th July.

RESOLVED—That the assessments contained in Valuation Sheets Nos. 1 to 8 be approved and signed.

4.—REQUISITIONS:

Requisitions amounting to £4 10s. 0d. for stationery, etc., were **approved**.

(Other matters dealt with are recorded in MS. in the Committee's Minute Book.)

Report (No. 1) of the Air Raid Precautions Committee.

16th May, 1939.

COMMITTEE:

*Councillor E. Arter, M.C., M.I.A.E. (*Chairman*).

Aldermen:

*W. R. Clemens, F.C.A.,

*J. J. Copestake, J.P.

Councillors:

*F. H. Bate,

C. H. Hignett,

*T. J. Scott,

*F. J. Collins,

*L. Hirshfield,

W. H. N. Shakespeare,

*A. W. Curton,

*A. A. Naar, M.B.E.,

M.C., A.F.C., J.P.,

*J. Griffiths,

*C. Pinkney,

*C. F. Windust.

*W. A. Hicks,

*H. G. Potter, J.P., F.S.I.

(*Mayor*),

* denotes Member present.

Also present: Councillors T. K. Bridge and A. W. Greville.

1.—REQUISITIONS:

Requisitions amounting to £132 13s. 3d. as set out hereunder were submitted and approved:—

	£	s.	d.			
Town Clerk's Department	83	0	3	—	—	—
Borough Engineer's Department	21	1	0	—	—	—
Public Health Department	28	12	0	—	—	—
	£132	13	3			

2.—REPRESENTATIVES OF A.R.P. SERVICES ON A.R.P. COMMITTEE:

It was reported that Captain A. G. Petrie had been nominated by the Divisional Wardens to represent the Wardens' Organisation, and that Mr. Harold Bevir had been nominated to represent the Auxiliary Fire Service on the Committee.

RESOLVED—That the nominations be approved.

FURTHER RESOLVED—That the representatives of the various A.R.P. Services be permitted to remain throughout the sittings of Meetings of the Committee.

3.—SHELTER ACCOMMODATION:

(A).

Trenches in course of construction.

The Borough Engineer reported that the trench system at Child's Hill had been completed; the steel linings to the trenches at Hendon Park and Stone Grove Park would be complete by the end of the week, and that the fixing of the steel linings to the trenches in York Park and Watling Park was in hand. The drainage works for trenches at Hampstead Heath had been commenced, but it would be necessary to deepen these trenches before lining them, and this work would be put in hand as soon as possible after the completion of the drainage works.

With regard to the trenches at Hendon Grove, the Borough Engineer reported that the first consignment of steel linings had just been received, and that this consignment was the first Messrs. Guest, Keen Baldwins Iron & Steel Company had been able to send.

(B).

Further Trenches.

On the report of the Borough Engineer regarding the provision of additional trenches to provide accommodation for 10 per cent. of the population after allowing for shelters in basements and cellars, etc., the Committee

RESOLVED TO RECOMMEND—That on receipt of the authority of the Home Office to the construction of the further trenches, the Borough Engineer be authorised to obtain tenders from six reliable firms of public works contractors for the construction of such trenches.

[Having considered the matter in its financial bearing, the Finance and General Purposes Committee concur in the proposal.]

4.—CENSUS OF VEHICLES:

The Borough Engineer reported that the full complement of transport required, viz., 213 vehicles, had now been obtained and the registration numbers transmitted to Headquarters for the purpose of earmarking such vehicles. **Noted.**

5.—TRAINING OF AMBULANCE DRIVERS:

The Borough Engineer reported that 96 women ambulance drivers are at present in training, 48 of whom have passed the preliminary test and are now practising driving light lorries of the type which will be used as emergency ambulances.

For the information of the Committee the Borough Engineer reported that the driving instruction to ambulance drivers was being given voluntarily by Mr. A. W. Greville, Mr. F. W. Timson, Mr. S. G. B. Skingle, Mr. C. Freeman, Mr. C. Howes, Mrs. Skingle and Mrs. Shakespeare, but that owing to illness Mrs. Shakespeare had not up to the moment been able to take an active part in the training.

RESOLVED TO RECOMMEND—That the Council place on record their appreciation of the services rendered by the voluntary instructors and that they be accorded the sincere thanks of the Council.

6.—PURCHASE OF VEHICLE FOR TRAINING AMBULANCE DRIVERS:

The Borough Engineer reported that in accordance with the authority of the Council he had purchased three vehicles for the purpose of training ambulance drivers and asked for authority to purchase a further vehicle at a cost of £15. The three vehicles already purchased and the vehicle proposed to be acquired can be equipped as emergency ambulances.

RESOLVED TO RECOMMEND—That the Borough Engineer be authorised to purchase a further vehicle at a cost of £15.

[Having considered the matter in its financial bearing, the Finance and General Purposes Committee concur in the proposal. The approval of the Middlesex County Council has been obtained.]

7.—PROVISION OF AIR RAID SHELTERS:

The Borough Engineer reported that the work of the Buildings Section of his Department had now been more clearly defined by the issue of Home Office Circular No. 91, dated 25th April, 1939, indicating the Government's policy on the provision of air raid shelters, and that this must be taken in conjunction with the Civil Defence Bill which imposes certain duties upon Local Authorities in connection with certain classes of buildings.

The policy of the Government as laid down by the Home Office is as follows:—

- (1) Shelter for employees at their place of work,
- (2) Shelter for persons at home,
- (3) Public shelter for persons caught in the streets and for whom no private shelter is available.

The three classes of shelter are dealt with as follows:—

(1) Shelter for Employees:

The Lord Privy Seal points out that at the present time there is no statutory duty on the Local Authorities to provide shelter for their own employees, but pending the passing of the Civil Defence Bill now before Parliament he has no doubt that Local Authorities will desire to anticipate the passing of that Bill by proceeding with the provision of shelter for their employees. Exchequer grants described in Clause 17 of the Bill would be payable to Local Authorities on the same terms and conditions as now given to other employers.

The Borough Engineer therefore suggested that the trenches under construction at the rear of the Town Hall should be regarded as provision for the employees of the Council working in the Town Hall and adjacent buildings and that application for exchequer grant be made in due course.

RESOLVED TO RECOMMEND—That the proposal of the Borough Engineer be approved and in due course application be made for grant towards the cost of construction of such trenches in accordance with Clause 17 of the Civil Defence Bill.

[Having considered the matter in its financial bearing, the Finance and General Purposes Committee concur in the proposal.]

The Civil Defence Bill also places certain duties on the Council with regard to employers generally in the area. Part III. of the Bill provides that provision of shelters will be obligatory for any establishment in the category of a factory or commercial building in which more than fifty persons are employed if it is situated in an area which has been specifically designated by the Minister in a special Order.

The Minister will shortly issue a code indicating the types of shelters appropriate to different classes of establishments. The cost of such shelters is to be borne by the owner or occupier of the building in question and certain grants towards such costs will be paid by the Government. Until the Minister indicates whether Hendon is to be included in the Order or not little progress can be made in this matter. In any case it appears that Local Authorities will only be required to deal with commercial buildings. Factories are left to the Factory Inspector to deal with under Clause 2 of the Bill.

The Bill also gives power to the Minister under Clause 24 to make regulations imposing requirements as to materials and construction of new buildings of the classes he may specify with the object of making them less vulnerable to air raids. He may also make regulations and requirements as to the provision of air raid shelters for such buildings. These will be enforced by the Local Authorities in a similar manner as the building byelaws are enforced.

The Committee have noted the report of the Borough Engineer on this aspect of the Bill and await the Order to be made by the Minister in connection therewith.

(2) Shelters for Persons at Home:

The Home Office propose to limit the provision of air raid shelters to householders whose occupations are compulsorily insurable under the National Health Insurance Act, or who are mainly dependent on earnings not exceeding £250 per annum to be increased by £50 for each child of school age in excess of two.

Houses not exceeding two storeys in height without basements but having garden space are to be provided with "Anderson" Steel Shelters, subject to the income limitation mentioned above.

The Home Office require a preliminary estimate to be forwarded as soon as possible of the number of houses coming within this description and occupied by persons within the income limits specified. This estimate is to be forwarded by all Authorities included in Appendix I. of Home Office (A.R.P. Department) Circular No. 91, which includes Hendon.

The Borough Surveyor informed the Committee that in his opinion the number of houses in Hendon coming within this category is approximately 23,000.

A survey is also to be put in hand of all dwellings of more than two storeys in height and of all houses or flats without garden space sufficient for a shelter, occupied mainly by the persons within the income limit specified. The arrangements to be made for protection in these cases are:—

- (a) Strengthening of existing basements where possible,
- (b) In blocks of buildings by provision of a shelter sufficiently large to accommodate persons living therein.

This survey will involve not only preparing lists of different classes of properties, but in the case of houses without garden space and in the case of flats, the preparation of designs and estimated quantities of materials which have to be submitted to the Regional Technical Officers. The Home Office is to standardize materials and will make the necessary issues thereof direct to the premises concerned wherever possible.

(3) Public Shelters:

Local Authorities are required by Circular No. 91 to provide public shelter for persons likely to be caught in the streets and for persons within the scheme of free provision of shelter for whom such shelter cannot be provided at their houses by any of the methods already indicated. The need in this respect is to be the subject of a special survey designed to furnish the following information:—

- (a) The number and allocation of business centres and the estimated day population therein.
- (b) The extent to which existing business and commercial cellars are available in such areas and the methods to be adopted for adapting them as public shelters.

In this connection due regard must be paid to the occupier requiring the whole or part of such accommodation for his employees.

- (c) Any other accommodation which could be used or adapted to serve as a public shelter.

The Home Office propose to furnish further technical information as to methods of strengthening large basements to serve as public shelters.

As a general standard it is stated the Local Authority should aim at providing for about 10 per cent. of the population in mainly residential areas and about 15 per cent. of the day population in business areas. It is recommended in the circular that the responsibility for supervising the carrying out of the shelter programme should be placed on the Engineer to the Authority, subject to the general control of the Local Authority and that a Chief Assistant be selected from the permanent staff. Authority is also given to engage such additional technical staff as may be required. On the assumption that the County Council will delegate the work involved to Local Authorities in Middlesex, the Borough Engineer reported that he had provisionally made the following arrangements in connection with staff:—

- (a) Mr. L. A. Jones (Chief Building Inspector) to be seconded as Chief Assistant for the shelter programme.
- (b) Mr. J. O. Vine (Assistant Building Inspector) to be seconded for the same purpose, as assistant.
- (c) Two additional temporary Assistants to be appointed as required.

The Borough Engineer pointed that although the Home Office are not prepared to allow the salaries of the permanent staff engaged to rank for grant, they are prepared to allow additional expenditure to rank for grant if it falls on the Local Authority as a result of the engagement of a substitute. At the present time, however, the Borough Engineer does not propose to engage a substitute for the Chief Building Inspector.

The Borough Engineer further reported that he had already put the work in hand on the lines indicated in his report and for the information of the Committee submitted a map showing the chief business centres in the area and the estimated population which can be accommodated in shelters.

RESOLVED TO RECOMMEND—

- (a) **That the report of the Borough Engineer be approved.**
- (b) **That the Home Office be informed that the number of "Anderson" Steel Shelters which will be required to meet the needs of the Borough is estimated at 23,000.**
- (c) **That the Borough Engineer be instructed to proceed with the requisite surveys and the preparation of plans, etc., as speedily as possible and to submit them to the Committee in due course prior to transmission to the Authorities concerned.**

8.—PETROL SUPPLIES:

The Borough Engineer reported that he had been requested to supply information with regard to the probable petrol consumption of all transport which will be in use during a time of emergency and that he had compiled the necessary information and transmitted the same to the Mines Department of the Board of Trade. **Noted.**

9.—PERSONNEL:

Decontamination, Rescue and Demolition Services.

The Borough Engineer reported that the number of volunteers enrolled for the above services now totals 321 of which number 149 are trained or in training. **Noted.**

10.—RESCUE AND DEMOLITION SERVICES:

The Borough Engineer reported the receipt of Home Office Circular No. 104, dated 5th May, intimating that it was proposed to set up a Central Committee consisting of representatives of the National Federation of Building Trades Employers, The National Federation of Building Trades and Civil Engineering Operatives, the Federation of Civil Engineering Contractors and a number of professional Institutions, together with representatives of the Government Departments concerned, and that this Committee will assist and advise the Minister on any matters affecting these industries connected with Civil Defence.

The Minister suggests that in addition to the Central Committee, which will deal with general principles, it will be of assistance to Local Authorities if local organisations were built up on the basis of existing Joint Organisations of the Constructional trades. It is suggested that a Local Committee might suitably consist of members of the Local Authority or of such officials of the Local Authority as may be appropriate, together with such representatives of the Constructional Industries and the professional bodies

as might be agreed upon locally. Such Committee would render assistance to Local Authorities in peace time in connection with such works as the construction of shelters, protection of existing buildings, strengthening of basements and in the recruitment and training of rescue parties and the organisation of demolition work. In the event of war the Local Committee could give help in the restoration of damage caused by hostilities to bridges, roads and public utility works and with essential repairs to houses, hospitals, etc.

It is assumed that the Middlesex County Council will agree to the Local Authorities in Middlesex forming one of these Committees for each area, in which case it would be advisable to approach one or two Builders and Contractors having local depôts and stores of plant and materials and to form, with such other representatives as the Council may desire, a Committee to take over the duties enumerated. In this connection the Borough Engineer referred to the decision of the Committee to appoint representatives of the Decontamination, Rescue and Demolition Services to attend the Air Raid Precautions Committee, and suggested that the appointment of such representatives would not now be necessary as the local Works Committee would report direct to the Air Raid Precautions Committee.

In view of the terms of the Home Office Circular No. 104, referred to above, the Committee

RESOLVED—That the question of the appointment of representatives of the Decontamination, Rescue and Demolition Services on the Air Raid Precautions Committee be deferred for further report by the Borough Engineer.

11.—STREET LIGHTING:

(A). *Masking of Traffic Control Signals.*

On the report of the Borough Engineer hereon, the Committee

RESOLVED TO RECOMMEND—That approval be given to the expenditure of the sum of £30 in connection with the masking of traffic light signals.

[Having considered the matter in its financial bearing, the Finance and General Purposes Committee concur in the proposal subject to the approval of the Middlesex County Council.]

(B). *Extinguishing of Street Lamps.*

The Borough Engineer submitted a letter from the Gas, Light & Coke Company suggesting that the same system should be put into operation in connection with the extinguishing of street lighting as was adopted during the Crisis of September last. The cost of the labour involved will be charged to the Local Authorities concerned.

RESOLVED TO RECOMMEND—That the proposals be approved.

[Having considered the matter in its financial bearing, the Finance and General Purposes Committee concur in the proposal.]

12.—MULTI-PURPOSE BUILDINGS:

The Borough Engineer reported that working drawings are now in hand for the three multi-purpose buildings and that several consultations had taken place with County Council Officials with a view to incorporating the latest Home Office ideas which had changed somewhat since the Conference with Home Office Officials when the erection of the buildings was approved. **Noted.**

13.—FIRST AID POSTS:

It was reported that drawings had been submitted to the Middlesex County Council for the First Aid Posts at the Isolation Hospital and the Hendon Cottage Hospital and that a similar scheme for a First Aid Post at Colindale Hospital was in course of preparation.

14.—STORAGE ACCOMMODATION:

(A).

Hendon Way Depot.

The Borough Engineer reported that tenders had been received for the erection of a timber framed store at Hendon Way Depot to replace the building destroyed by fire some months ago and that in accordance with the authority given by the Council (A.R.P.C., 19/4/39—14 (iii)) the lowest tender received, namely that of Buckingham and Sons, had been accepted and the work is now well in hand. **Noted.**

(B).

Sandbags.

The Borough Engineer reported that negotiations with the London Passenger Transport Board for the use of a large arch under the Board's railway in the vicinity of Montrose Playing Fields had been completed and possession taken of the archway, and that the preparations for making it ready to store sandbags are well in hand.

In this connection the Town Clerk reported that the Middlesex County Council had intimated their approval to the use of the arch for the purpose in question and the rent agreed to be paid. **Noted.**

15.—BOROUGH OF FINCHLEY—RECIPROCAL ARRANGEMENTS:

A letter was submitted from the Finchley Borough Council intimating that that Authority raised no objection to the proposal whereby the casualty organisation for the Woodside Park Area would be covered by that authority's first aid posts at St. Mary's School, Finchley Memorial Hospital, and the mobile unit attached thereto, and suggesting that in view of the fact that the Woodside Park Area was to be provided for by the first aid posts referred to such area might come under the purview of the Finchley Council's A.R.P. Services as a whole, and asking the Committee to give consideration to the proposal.

In this connection the Medical Officer of Health intimated that subject to the necessary approval of the respective Councils, he had agreed with the Medical Officer of Health, Finchley, that the Hendon Borough Council should be responsible for the A.R.P. (Medical Services) for that part of Finchley which lies to the south of the Barnet Bye-Pass and delineated in blue on the map which had been forwarded by the Medical Officer of Health for Finchley.

The Town Clerk reported that he had discussed the matter with the Council's A.R.P. Officer and that it appeared desirable that apart from the casualty organisation the respective services should be carried out by each of the authorities concerned in their respective areas, the Committee therefore

RESOLVED TO RECOMMEND—

- (a) That the Council approve of the arrangements made between the Council's Medical Officer of Health and the Medical Officer of Health of the Finchley Borough Council whereby this authority shall be responsible for the Air Raid Precautions (Medical Services) for that part of Finchley which lies to the south of the Barnet Bye-Pass and delineated in blue on the map forwarded to the Finchley Medical Officer of Health and that the Finchley Council shall be responsible for the Air Raid Precautions (Medical Services) in respect of the Woodside Park area.
- (b) That the Finchley Borough Council and also the Middlesex County Council, to whom a copy of the letter from the Finchley Borough Council had been forwarded, be informed that the Council are unable to agree to any of its Air Raid Precautions Services relative to the Woodside Park area apart from the casualty organisation, being transferred to the Finchley Borough Council.

16.—CASUALTY ORGANISATION PERSONNEL:

The Medical Officer of Health reported that with the exception of First Aid Parties the recruitment of female voluntary personnel continues satisfactorily, but that there was still a large deficiency of volunteers for stretcher bearer parties. **Noted.**

17.—AMBULANCE DEPOTS:

The Medical Officer of Health reported that satisfactory arrangements had been made with the owners of Saunders Garage, 616, Finchley Road and the Apex Corner Garage for permission to use their premises as Ambulance Stations in time of emergency. **Noted.**

18.—FIRST AID POSTS—MEDICAL PRACTITIONERS:

The Committee considered as to the progress being made regarding the allocation of medical practitioners for duty at First Aid Posts and have directed the Medical Officer of Health to submit a report on the progress in the matter to the next meeting.

19.—WARDENS' FIRST AID TRAINING:

The Medical Officer of Health reported that arrangements are being made whereby wardens will be given a short course in first aid as set out in Home Office Circular 16/1939 and that it is proposed to commence training next week through the Voluntary Associations. **Noted.**

20.—AUXILIARY NURSING:

The Medical Officer of Health reported that a scheme has been inaugurated by the Central Emergency Committee of the Nursing Council and is being operated through the County Council for the purpose of supplementing nursing personnel in hospitals as the present shortage will become much more acute should air raid casualties fall to be dealt with.

The candidates accepted for this service are trained in first aid and home nursing and are required to attend a course of hospital duties extending over 96 hours. The County Council have asked that this Council should be responsible for the preliminary training of such volunteers in this area and the training is being carried out through the St. John Ambulance Brigade and the British Red Cross Society. The hospitals in the area co-operating in the scheme are the Redhill County Hospital and the Manor House Hospital. **Noted.**

21.—REPORT OF AIR RAID PRECAUTIONS OFFICER:

(1). *National Service—July Demonstration.*

The A.R.P. Officer reported that in view of the fact that a National Service Demonstration should be representative of all services and voluntary organisations, he proposed to arrange a meeting of all concerned and to draw up a programme. The date proposed for holding the Demonstration is Thursday, the 20th July next. He suggested that selected buildings, such as a Control Centre, Report Centre, a Warden's Post, First Aid Post, Fire Station, a Police Station, Drill Halls and Barracks, etc., should be open to the public during the afternoon to be followed in the evening by a demonstration on the lines of a tattoo; the demonstration either to be preceded or terminated by a representative parade of all services. An intimation had been received from the Home Office that the co-operation of the R.A.F. for the demonstration may be anticipated and the 36th Middlesex Anti-Aircraft Battalion (R.E.), with whom he had been in touch, would also co-operate if the exigencies of the service permit. He proposed to get into touch with all other units, services, and voluntary organisations in the Borough.

RESOLVED TO RECOMMEND—That the proposals outlined in the report of the A.R.P. Officer be approved.

(2). *Air Raid Wardens' Organisation.*

The present position regarding the recruiting and training of Air Raid Wardens is as follows:—

War Establishment and Reserves	2,400
Enrolled to Date	1,941
Training in Anti-gas measures	1,161
In training (anti-gas)	529
Enrolled but no training commenced	520

The A.R.P. Officer reported that it was desirable that the internal administration of the organisation should, as far as possible and subject to guidance from headquarters, be taken over by the Warden officials and in this connection a meeting of Divisional Wardens and their Deputies was held on the 12th instant.

The A.R.P. Officer also reported that it was desirable that the training in the three Divisions should be of a uniform character and indicated his proposals in connection therewith. He had instructed the Divisional Wardens to submit to him names of Warden officials who are likely to make suitable instructors and he proposed holding two courses consecutively of 20 instructors each which would enable 40 instructors to be available for the further training of Wardens.

During the period in which the A.R.P. Officer would be training the first class of instructors, training in "First Aid to the Injured" and "Relations with the Police and Public" will be given to all Wardens, and also, where still required, training in the Auxiliary Fire Service organisation.

In order that collective training can be proceeded with immediately individual training is completed, the A.R.P. Officer is arranging to train Divisional and Head Wardens and their Deputies in the general principles of collective training and setting of exercises. **Noted.**

(3). *Air Raid Wardens' Posts.*

Action is now being taken in regard to the establishment of Wardens' Posts and a further report will be submitted to the Committee in due course.

(4). *Distribution of Civilian Respirators.*

It was reported that in the Central and South Divisions the issue of civilian respirators to the public has been completed and that in the North Division 35 sectors still remain to be dealt with and arrangements are being made for the distribution to be expedited. **Noted.**

(5). *Communications Service—Report Centre Staff and Messengers.*

The position regarding the recruitment of the above services is as follows:—

Report Centre Staffs:

War establishment and reserves	180
Enrolled to date	151

Messengers:

War establishment and reserves	112
Enrolled to date	45

Arrangements had been made for all personnel in these services to undergo the requisite training commencing with instruction in anti-gas measures and in due course special training in report centre procedure and message work will be given the Report Centre Staffs.

(6). *Presentation of Badges and Brooches.*

The Committee have authorised the Air Raid Precautions Officer to make special arrangements for the presentation of A.R.P. badges and brooches in future.

22.—AIR RAID PRECAUTIONS OFFICER—CAR ALLOWANCE:

RESOLVED TO RECOMMEND—That subject to the approval of the Middlesex County Council a car allowance of £60 per annum be paid to the Air Raid Precautions Officer.

[Having considered the matter in its financial bearing, the Finance and General Purposes Committee concur in the proposal. The approval of the Middlesex County Council has been obtained.]

23.—TELEPHONE:

RESOLVED TO RECOMMEND—That subject to the approval of the Middlesex County Council a telephone be installed at the private residence of the Air Raid Precautions Officer and the cost charged to A.R.P. Account.

[Having considered the matter in its financial bearing, the Finance and General Purposes Committee concur in the proposal. The approval of the Middlesex County Council has been obtained.]

24.—CHIEF WARDEN:

The Committee received and **noted** letters from Captain A. G. Petrie, Lt. Commander R. F. Paget, Mr. Louis Levy and Mr. M. B. Barney relative to the question of a Chief Warden.

25.—HENDON CHAMBER OF COMMERCE:

A letter was submitted from the Hendon Chamber of Commerce stating that in the present state of national anxiety owing to international events the Hendon Chamber of Commerce is deeply conscious of the fact that it should be in a position to do all it can to assist the Local Authority in any way deemed fit and offering the services of the Executive Committee to the Council should a state of Emergency arise.

RESOLVED TO RECOMMEND—That the Hendon Chamber of Commerce be informed that the Council greatly appreciate the offer of the services of the Executive Committee should a state of emergency arise and that they be accorded the cordial thanks of the Council for such offer.

26.—HENDON HEAD TEACHERS' ASSOCIATION:

The Committee considered representations from the Hendon Head Teachers' Association asking to be represented on the Air Raid Precautions Committee.

RESOLVED TO RECOMMEND—That the Hendon Head Teachers' Association be informed that in the event of any matters coming before the Air Raid Precautions Committee in which the services of the Head Teachers' Association could be used with advantage they will be invited to send a representative to attend meetings of the Committee at which such matters may be under consideration.

27.—FIRST AID BOXES FOR WARDENS' POSTS:

The Town Clerk submitted Home Office (A.R.P. Dept.) Circular No. 92 intimating that tenders have now been received for the central purchase of First Aid Boxes for Wardens' Posts at a price not exceeding 3/8d. each and asking the Council to submit their specific requirements as soon as possible.

RESOLVED TO RECOMMEND—That authority be given to place an order with the Home Office for the requisite supplies of First Aid Boxes for Wardens' Posts at the price indicated.

28.—HOME OFFICE A.R.P. STAFF SCHOOL, LONDON:

It was reported that a vacancy for a special course at the A.R.P. Staff School, London, on the training of First Aid (Stretcher) Parties had been allocated to Hendon, and that as a matter of urgency Dr. S. L. Wright, M.D., D.P.H., had been allotted to the course commencing on Wednesday, the 17th instant and terminating on Thursday, the 25th instant.

RESOLVED TO RECOMMEND—That the nomination of Dr. Wright be approved.

29.—RESIGNATION OF DIVISIONAL WARDEN:

The Town Clerk reported that Lt. Com. R. F. Paget, R.N. (Rtd.), the Divisional Warden for the South (No. III.) Division had obtained a post which would necessitate his being away from the Borough and that he had therefore tendered his resignation as Divisional Warden, and had handed over to Mr. Louis Levy, Deputy Divisional Warden.

RESOLVED TO RECOMMEND—That the Council do place on record its keen appreciation of the valuable services performed by Lt. Com. Paget, R.N. (Rtd.) as Divisional Warden of the South (No. III.) Division and that the Town Clerk be directed to convey by letter to Lt. Com. Paget the Council's very grateful thanks for his services.

30.—DIVISIONAL WARDEN—SOUTH DIVISION:

Arising out of the resignation of Lt. Com. Paget the Committee have considered as to the appointment of a successor, and

RESOLVED—That the Air Raid Precautions Officer be instructed to submit a recommendation in due course for the appointment of a successor to Lt. Com. Paget and that in the meantime the duties of Divisional Warden be carried out by the Deputy Divisional Warden, Mr. Louis Levy.

31.—MANOR HOUSE HOSPITAL FETE:

It was reported that the Manor House Hospital authorities had enquired whether the Council would be prepared to authorise an A.R.P. Demonstration in conjunction with the Manor House Hospital Fete to be held on the Burroughs Playing Field on Saturday, the 26th August next.

The Committee have instructed the Air Raid Precautions Officer to submit a report on the matter to the next meeting of the Committee.

32.—NATIONAL SERVICE RALLY—HYDE PARK:

A letter was submitted from the Home Office (A.R.P. Dept.) stating that arrangements are being considered for the holding of a National Service Rally in Hyde Park on July 2nd next to take the form of a march past, and that His Majesty the King had graciously consented to take the salute.

It is the intention to make arrangements for a representative contingent of local Air Raid Precautions and Auxiliary Fire Service services to take part in the march and further details will be forwarded as soon as possible.

The Committee have instructed the Air Raid Precautions Officer to make the necessary arrangements for the attendance of representative contingents from the Council's Air Raid Precautions and Auxiliary Fire Services.

33.—POLITICAL MEETINGS:

The Air Raid Precautions Officer asked the Committee for directions as to whether it would be in order for him to give addresses on A.R.P. matters at meetings and other functions arranged by political parties.

The Committee have authorised the Air Raid Precautions Officer to give addresses on A.R.P. matters at such meetings and functions.

34.—MEETING OF COMMITTEE:

RESOLVED—That the next meeting of the Committee be held on Tuesday the 30th May at 6 p.m.

D
E
F
G
H
I
J
K
L
M
N
O
P
Q
R
S
T

Report (No. 2) of the Air Raid Precautions Committee.

30th May, 1939.

COMMITTEE:

*Councillor E. Arter, M.C., M.I.A.E. (Chairman).

Aldermen:

W. R. Clemens, F.C.A.,

*J. J. Copestake, J.P.

Councillors:

*F. H. Bate,
*F. J. Collins,
A. W. Curton,
J. Griffiths,
*W. A. Hicks,

*G. H. Hignett,
L. Hirshfield,
*A. A. Naar, M.B.E.,
*G. Pinkney,
*H. C. Potter, J.P., F.S.I.

T. J. Scott,
*W. H. N. Shakespeare,
M.C., A.F.C., J.P.,
*C. F. Windust.

(Mayor),

Representatives of A.R.P. Services:—

Wardens' Organisation	*Captain A. G. Petrie,
Auxiliary Fire Service	*Mr. Harold Bevir.

* denotes attendance at Meeting.

1.—GOVERNMENT EVACUATION SCHEME:

A communication was submitted from the Minister of Health calling attention to the following Question and Answer in the House of Commons on the 18th instant:—

“ Mr. Kirby—(Everton):—

To ask the Minister of Health, whether he has considered the representations made by various local authorities as to their classification for the purposes of the Government evacuation scheme; and whether he is now in a position to make any statement on this matter.

Mr. Elliot:—

Yes, Sir. I have considered this matter in consultation with my right hon. Friend the Lord Privy Seal. Our desire has always been that every practicable effort should be made to get the maximum number of children, whatever their circumstances, from congested areas to safer conditions. I am satisfied that there are certain towns, in addition to those now covered by existing plans, for which a measure of evacuation should if practicable be carried out. In this connection I have also considered the representations made by a number of authorities to the effect that their districts are not suitable as reception areas. I have decided that the following districts should not be required to act as receiving areas under present conditions:—

Boroughs—Chesterfield, Dover, Goole, Hedon, Rugby, Scunthorpe.

Urban Districts—Bolsover, Dronfield, Leyland, Staveley.

I recognise that a number of other districts, by reason of their position, or their proximity to works of military importance, may be considered to be open to criticism as receiving areas. We cannot, however, escape from the fact that in this small and industrialised country, under the possible conditions of air warfare, safety is only relative. But clearly, even with these disadvantages, the reception areas offer a much better chance of safety than many districts in which children now live. I am sure that those authorities who have quite properly put before me what appear to them the disadvantages of their districts as receiving areas, will recognise the force of this view.

I am happy to say that, after allowing for the reduction mentioned, a margin of accommodation remains potentially available for the extension of the evacuation scheme to certain other areas not covered by present plans. It will be appreciated that the extent to which plans for additional areas can be worked out depends on a number of factors, but I intend to review the following:—

County Boroughs—Coventry, Derby, Grimsby, Middlesborough, Nottingham, Rotherham, South Shields, Sunderland, Tynemouth and West Hartlepool.

Boroughs—Hartlepool, Jarrow and Wallsend.

Urban Districts—Felling, Hebburn and Whickham.

There are in addition portions of certain areas on Thames side or on the borders of the Metropolitan evacuation area, and also in the neighbourhood of Birmingham, which will be included in the review.

Other towns not included in this list have made representations that their areas should be evacuated. I have examined the case that they have put up with great care, and willingness to respond to their appeal if it were possible, but have been forced to the conclusion, in view of all the factors, that further extensions of evacuation plans, beyond what I have already stated, are impracticable.

I have instructed my officers to take up forthwith with the local authorities concerned the question of working out plans for the areas under review. It will, of course, be understood that until detailed plans for any additional areas and arrangements for putting them into effect can be worked out, the present evacuation plans stand without modification.

I should like to pay tribute here to all those both in evacuating and receiving areas, and especially the latter, who are working so hard, and showing so fine a spirit, in their efforts to ensure the safety of the youth of our nation."

An enquiry has been addressed to the Minister as to whether Hendon is one of the areas on the borders of the Metropolitan evacuation area to be included in the review.

A communication has also been received from the Mill Hill Ratepayers' & Residents' Association expressing appreciation of the action taken by the Council in the matter and suggesting in addition that combined exercises should be carried out in the near future. **Noted.**

2.—REPRESENTATION OF AIR RAID PRECAUTION SERVICES:

Letters were submitted regarding the representation of the British Red Cross Society on the Air Raid Precautions Committee, and it was

RESOLVED—That the **Vice-President (Mrs. E. Monro, J.P.)** of the Hendon Division be appointed to represent the Society on the Committee, and that **Mrs. F. J. Harvey, Divisional Secretary**, be appointed as the deputy to attend meetings in the absence of the Vice-President.

3.—SHELTER ACCOMMODATION:

(A). *Trenches in Course of Construction.*

The Borough Surveyor reported the following as the present position in the above matter:—

Child's Hill Park	Completed.
Watling Park	Steel lining completed; covering in hand.
Hendon Park	Steel lining completed; covering in hand.
Stone Grove Park	Steel lining completed; covering in hand.
York Park	Fixing in progress.
Hampstead Heath	Steel in course of delivery; lining commenced to-day.
Clitterhouse Playing Fields	Steel will be delivered in about a week's time.
Mill Hill Park	Steel will be delivered in about a week's time.

The progress of the works are to a large extent determined by the regularity or otherwise in the delivery of steel linings.

(B).

Additional Trenches.

With regard to the programme of the construction of additional trenches, the Borough Surveyor reported the receipt of a letter from the County Engineer intimating that the Home Office had given approval for another 4,057 yards of trench at £5 19s. 4d. per yard, which is equivalent to a total cost of £24,207.

The original application was for an additional capacity of 13,550 persons, which would bring the total trench accommodation up to 10 per cent. of the population, but the Home Office have apparently deducted about 1,200 from the population, on the assumption that these can be accommodated in basements or other forms of shelter. The approval now given provides accommodation for approximately another 12,000 persons.

Consideration has been given to proposals for the construction of the proposed trenches, and in order to permit as far as possible of the continuance of the present user of the parks and open spaces and to avoid undue concentration, the Committee have

RESOLVED TO RECOMMEND—That tenders be obtained (see report, 16/5/39—3
(b)) **for the construction of the approved trenches on the following basis:—**

- (a) The trenches shall be lined with steel and about four inches of concrete placed at the back of the steel up to the level of the springing of the steel arch.
- (b) That instead of adapting the block system, the trenches consist of short lengths of straight trench arranged, as far as possible, round the boundary of the parks.

It must be understood that the Home Office, in their estimates, do not allow for the construction of the ramps into the trenches, the construction of the sanitary bays, or the provision of seating or lighting. The estimates to be obtained will, however, provide for sanitary bays, but additional expense on fittings for the bays, and the other items excluded from the estimates will be necessary in the event of emergency.

4.—AIR RAID SHELTERS:

(A).

Shelters for Persons at Home.

In connection with item 7 (2) of the report of the 16th May, the Borough Surveyor reported that additional information as to the numbers of householders falling within the limits for free issue of shelters had been obtained, which reduced his previous estimate to 15,000. The survey of other dwellings containing families also within the income tax limits, but for whom the proposed shelters cannot be provided, is in hand.

(B).

Public Shelters.

The Borough Surveyor reported the completion of a preliminary survey of the shopping centres and the amount of basement accommodation which will be available. The use of unoccupied shops for this purpose, is being abandoned, as unlikely to prove effective. The preliminary list is as follows:—

Shopping Centre.	Approximate Accommodation in Basements.
Green Man, Mill Hill	100
Mill Hill Broadway	40
Station Road, Edgware	200
Watling Avenue and Burnt Oak Broadway	460
Brent Street, Hendon	50
Temple Fortune	350
Hendon Central	617
The Broadway, West Hendon	400
Golders Green	2974*
Child's Hill	600
Total	5791

* Includes arches.

The total represents about 3½ per cent. of the whole population of the Borough and should be ample for dealing with people in streets in the various centres. This distribution, however, is deficient in some respects and it may be necessary to supplement it with other forms of shelter. Plans for the conversion of the basements and arches are in hand.

5.—FIRST AID POSTS:

(A).

Provision of Posts.

The plans first submitted (see 16/5/39—12) for First Aid Posts at the Hospitals in the locality were not approved by the Middlesex County Council, mainly on the ground of cost. Revised plans have now been prepared after consultation with the Medical Officers to the County Council and the Borough Council and have been submitted to the County Council for approval.

Plans are also in course of preparation for the adaptation of the house in Golders Hill Park for a first aid post in connection with Manor House Hospital, and also one of the wards in Colindale Hospital for the same purpose.

(B).

Manning of First Aid Posts.

The Secretary of the Local Medical Emergency Committee of the Hendon Branch of the British Medical Association has forwarded a list of Medical Practitioners who are willing to serve at the First Aid Posts and Mobile Units. The list has been approved by the Central Emergency Committee of the British Medical Association, and is as follows:—

Mobile Unit or First Aid Post.	Medical Practitioners.
Mobile Unit at Manor House Hospital	Dr. G. K. Cooper, 1, Rotherwick Road, N.W. 11. Telephone: Speedwell 3347. Dr. B. R. Isaacs, Finchley House, Finchley Road, N.W. 11. Telephone: Speedwell 2693.
First Aid Post at Manor House Hospital	Dr. W. W. Anderson, 3, Rotherwick Road, N.W. 11. Telephone: Speedwell 1846. Dr. E. C. I. Focke, 84, Addison Way, N.W. 11. Telephone: Speedwell 4610.
Mobile Unit at Redhill County Hospital	Dr. A. H. Morley, Grasmore, Hammers Lane, N.W. 7. Telephone: Mill Hill 1246. Dr. H. E. Brown, 2, Uphill Drive, N.W. 7. Telephone: Mill Hill 1582.

First Aid Post at Redhill County Hospital	Dr. W. T. Beswick, 30, Mill Way, N.W. 7. Telephone: Mill Hill 1242. Dr. H. G. Stormer, 39, Penshurst Gardens, Edgware. Telephone: Edgware 0108.
First Aid Post at Isolation Hospital...	Dr. M. Routledge, 1, Colin Close, N.W. 9. Telephone: Colindale 6146. Dr. G. C. Michael, Manor Lodge, Manor Park Gardens, Edgware. Telephone: Edgware 0880.
First Aid Post at Mill Hill Centre, Hartley Avenue, N.W. 7	Dr. E. Baron, 37, Ashley Lane, N.W. 4. Telephone: Hendon 3133. Dr. A. Crawford, 227, Great North Way, N.W. 4. Telephone: Hendon 6842.
First Aid Post at Colindale Hospital....	Dr. T. H. Meek, 4, Uphill Drive, N.W. 7. Telephone: Mill Hill 2336. Dr. A. Esterman, Galen, Watling Avenue, Burnt Oak, Edgware. Telephone: Mill Hill 1652.
First Aid Post at Hendon Cottage Hospital	Dr. R. Hunt-Cooke, 65, Vivian Avenue, N.W. 4. Telephone: Hendon 1722. Dr. R. W. Cockshut, 42, Station Road, N.W. 4. Telephone: Hendon 1292.

(C).*Allocation of Volunteers.*

A preliminary allocation of all available voluntary personnel for duty at the First Aid Posts and Mobile Units has now been made and notices will shortly be issued for them to meet in their respective groups in order to determine details of duty and to arrange for subsequent collective training and instruction. **Noted.**

6.—MULTI-PURPOSE BUILDINGS:

In connection with the preparation of plans for these buildings the Committee have considered the desirability of providing the following accommodation for women, viz., dressing-rooms, rest-rooms and a small decontamination centre. Such provision at each of the three multi-purpose buildings previously estimated at £29,000 would be much more efficient and cheaper, ultimately, than attempting to convert existing buildings at short notice, and is designed to provide accommodation for 186 women, including ambulance drivers, attendants and car drivers for the stretcher bearer section.

It is estimated that the cost of each building would be increased by £1,100, and the Committee

RECOMMEND—That the proposals be approved and that the plan be forwarded to the Home Office for approval.

[Having considered the matter in its financial bearing, the Finance and General Purposes Committee concur in the proposal.]

7.—TRAINING OF AMBULANCE DRIVERS:

Four vehicles have now been purchased and converted into emergency ambulances. (16/5/39—6).

Of the 96 women ambulance drivers in training, 50 are now training on the emergency vehicles, and 30 of these have reached the stage of taking the vehicles out on the public highways.

8.—PERSONNEL:

The present position is as follows:—

(a) Wardens' Organisation:—

War Establishment and Reserve	2,400
Enrolled to date	2,013
Trained in Anti-Gas Measures	1,400
In training (Anti-Gas and First Aid)	1,313
(Anti-Gas)	290
Enrolled but no training commenced	323

(b) Decontamination, Rescue and Demolition Services:—

Volunteers	342
Trained or in training	163

(c) Report Centre Staff and Messengers:—

Staff:—

War Establishment and Reserves	180
Enrolled to date	224

Training commences next week.

Messengers:—

War Establishment and Reserves	112
Enrolled to date	50
In training, (Anti-Gas)	48
Enrolled but no training commenced	2

9.—TRAINING—GENERALLY:

The Air Raid Precautions Officer reported that at present full facilities for training are not available and in order to provide the additional facilities still needed it was desirable to provide a model Cleansing Station and an Incendiary Bomb Demonstration Shed at "Ravensfield."

Practice incendiary bomb demonstrations in the open must not be permitted as an entirely false impression of their capabilities and effect is given, also training must be given in dealing with bombs in fire and smoke.

An urgent need exists for the provision of large rooms or small halls in each division which members of the various services can have the use of and meet in. In so far as the Central Division is concerned, a room for this purpose can be provided in "Ravensfield" and in the northern and southern Divisions temporary accommodation is necessary until the Multi-Purpose Buildings are completed.

RESOLVED TO RECOMMEND—

(1) That authority be given for the proposed provision of the:—

Model Cleansing Station—Estimated £12.

Bomb Demonstration Shed—Estimated £14.

(2) That the Air Raid Precautions Officer report on "suitable premises" in the northern and southern Divisions for the purpose stated.

[Having considered the matter in its financial bearing, the Finance and General Purposes Committee concur in the proposal subject to the approval of the Middlesex County Council.]

10.—NATIONAL SERVICE—JULY DEMONSTRATION:

In connection with item 7 of the report of the 16th May, the Air Raid Precautions Officer reported that meetings had been held with all concerned when preliminary arrangements were discussed. It is anticipated that arrangements will be on the lines already suggested, and as soon as communications are received from the organisations which will take part a draft programme will be submitted, together with an estimate of the expenditure to be incurred.

RESOLVED TO RECOMMEND—That the approval of the programme and final arrangements be referred to a Sub-Committee, consisting of the Mayor, the Chairmen of the Works and Fire Brigade Committee, Public Health and Medical Services Committee and the Estates, Parks and Allotments Committee, with Councillor T. K. Bridge, representing the Wardens' Organisation, subject to the submission of estimate of proposed expenditure in due course.

11.—NATIONAL SERVICE—AMBASSADOR CINEMA:

The Air Raid Precautions Officer reported that he had been approached as to the possibility of staging a demonstration or tableau in connection with the coming exhibition of the film "60 Glorious Years."

RESOLVED TO RECOMMEND—That subject to the Ministry of Labour agreeing to bear any cost on stage fittings and effects for the purpose, the proposal be approved and the Air Raid Precautions Officer authorised to arrange accordingly; otherwise that the arrangements be confined to a tableau of personnel.

12.—MANOR HOUSE HOSPITAL FETE—DEMONSTRATION:

The Air Raid Precautions Officer reported (see 13/5/39—30) that he had considered the question as to whether a Borough Air Raid Precautions Demonstration could be staged on the afternoon of the 26th August at the Manor House Hospital Fête, and that such arrangements could be made on a small scale as a means of advertisement of the services.

RESOLVED TO RECOMMEND—That authority be given for the Air Raid Precautions Officer to make the necessary arrangements.

13.—FOLLY FARM—BARNET:

The Barnet Urban District Council has enquired whether the Council are prepared to cover the above property in the Air Raid Precautions Services. Folly Farm is just over the Borough boundary and no convenient means of access for vehicles exists.

RESOLVED TO RECOMMEND—That the Barnet Urban District Council be informed that the Council regret that they are unable to accede to the request.

Report (No. 3) of the Air Raid Precautions Committee.

13th June, 1939.

COMMITTEE:

*Councillor E. Arter, M.C., M.I.A.E. (*Chairman*).

Aldermen:

W. R. Clemens, F.C.A.,

J. J. Copestake, J.P.,

Councillors:

*F. H. Bate,

*C. H. Hignett,

T. J. Scott,

*F. J. Collins,

*L. Hirshfield,

*W. H. N. Shakespeare,

*A. W. Curton,

*A. A. Naar, M.B.E.,

M.C., A.F.C., J.P.,

*J. Griffiths,

*C. Pinkney,

*C. F. Windust.

W. A. Hicks,

*H. C. Potter, J.P., F.S.I.

(*Mayor*),

Representatives of A.R.P. Services:—

British Red Cross Society	*Mrs. J. F. Harvey.
Wardens' Organisation	*Captain A. G. Petrie.
Auxiliary Fire Service	*Mr. Harold Bevir.

* denotes attendance at Meeting.

1.—SHELTER ACCOMMODATION:

(A).

Trenches in Course of Construction.

The Borough Engineer reported on the present position of the work of lining and completing trenches already excavated in the various Parks as follows:—

Child's Hill Park, Hendon Park, Stone Grove Park	Completed.
Watling Park	Work will be completed by the end of this week.
York Park	Fixing of steel linings will be completed this week.
Hampstead Heath Extension	Fixing of steel work in progress.
Clitterhouse Playing Fields and Mill Hill Park	Deliveries of steel are expected this week.
Basing Hill Park	} Work not yet commenced.
Sunny Hill Park	
Hendon Grove	
Arrandene Open Space	
Edgwarebury Park	

(B).

Additional Trenches,

With regard to the 4,057 yards of trenches referred to in Item 3 (b) of Report (No. 2) of the Committee held on the 30th May, the Borough Engineer reported that plans, specifications and Bills of Quantities are in course of preparation to enable tenders for their construction to be obtained. In this connection the Borough Engineer suggested that the linings of these trenches should be seven feet in width in accordance with the cross-section submitted to the Committee. It is understood that linings of this width will expedite the deliveries of steel.

RESOLVED TO RECOMMEND—That subject to the approval of the Middlesex County Council the suggestion of the Borough Engineer be approved and adopted.

2.—TRAINING OF AMBULANCE DRIVERS:

The Borough Surveyor reported that of 96 women ambulance drivers at present in training, 65 are now qualified to drive vehicles on public highways, and that training in driving whilst wearing respirators is commencing this week.

3.—PERSONNEL:

Decontamination, Rescue and Demolition Services.

The number of enrolments in the above services now totals 347. Decontamination parties are being formed mainly from the Corporation's employees. The Borough Engineer reports that there is a definite shortage of men for the Rescue and Demolition Parties. The type of man required for this work can only be obtained through the building and public works contractors in the area, and the Borough Engineer suggested that it would be advisable to form a small Committee, on which the public works contractors would be represented to recruit and organise the rescue and demolition services. The Committee are informed that Mr. Howard Farrow, who is a local public works contractor with two depôts in the area, had volunteered his services in connection with the formation of such a Committee.

RESOLVED TO RECOMMEND—That the formation of a Committee on the lines indicated in the Borough Engineer's report be approved and adopted.

4.—MULTI-PURPOSE BUILDINGS:

The Borough Engineer reported that working drawings for the Multi-Purpose Building at Claremont Road to serve the South (No. 3) Division are practically completed, and will be forwarded to the Quantity Surveyor in the near future.

With regard to the Multi-Purpose Building to serve the Northern (No. 1) Division, it will be recalled that the original intention was to site this building in Lyndhurst Park, Mill Hill, but that the Borough Engineer was instructed to submit a further report after certain enquiries in connection with the site had been completed. The Borough Engineer now suggests that the multi-purpose building to serve this Division should be erected in Mill Hill Park, fronting Daws Lane. This site is more accessible and centrally situated to serve the area.

RESOLVED TO RECOMMEND—That subject to the approval of the Middlesex County Council and satisfactory arrangements being made regarding the site, the Multi-Purpose Building to serve the Northern (No. 1) Division be erected in Mill Hill Park, fronting Daws Lane.

5.—FIRST AID POSTS:

The Borough Surveyor reported that revised plans for a First Aid Post at the Isolation Hospital and the Hendon Cottage Hospital (A.R.P.C., 3/6/39—5 (A)), together with an estimate of the cost amounting to £2,500 for each building had been transmitted to the Middlesex County Council. In this connection, a letter was reported from the County Medical Officer intimating that the lay-out and types of buildings had been accepted by the Ministry of Health who now required the submission of detailed estimates to enable formal sanction to be issued for the work to be put in hand. The detailed estimates will be submitted at the earliest possible date. The Borough Surveyor also reported that plans had been prepared for the following First Aid Posts:—

The Mansion, Golders Hill Park.—The plans for this First Aid Post indicate the work which will require to be executed immediately (at a cost of £100), and also that which can be left in abeyance for the time being, the cost of which will amount to £85.

Ward at Colindale Hospital.—The cost of the necessary alterations to a ward at this hospital to serve as a First Aid Post is estimated at £250.

Clinic, Hartley Avenue.—With regard to work to be carried out in connection with the adaptation of these premises as a First Aid Post, it will be necessary to incur immediate expenditure amounting to £100 and further expenditure estimated at £42.

The Borough Surveyor points out that the estimated costs detailed above do not include for the provision of sandbag protection to windows or auxiliary lighting equipment. It is also pointed out that the figures do not include any sum for the provision of protection for the nucleus staff which will be in these buildings in war-time. It is not possible to make any suggestion in this respect regarding the hospitals and buildings not vested in the Council, but the Borough Surveyor suggested that when submitting the plans of the Hartley Avenue Clinic to the Minister of Health, a suggestion be put forward that separate provision should be made for the protection of the nucleus personnel by means either of a surface shelter or a covered trench in the ground at the back of the building, and that a provisional estimate of £100 be added for this purpose.

RESOLVED TO RECOMMEND—That the proposal of the Borough Surveyor be approved and adopted.

6.—HENDON WAY DEPOT—STORAGE ACCOMMODATION:

The Borough Engineer reported that this building has now been completed.

7.—A.R.P. HEADQUARTERS—RAVENSFIELD:

The Borough Engineer reported that in conjunction with the Air Raid Precautions Officer an inspection had been made of Nos. 1 and 2, Ravensfield, and he estimated the cost of carrying out the necessary redecorations and alterations, including the re-painting of the whole of the exterior of the building, at £125.

RESOLVED TO RECOMMEND—That the estimate be approved that the Borough Engineer be instructed to put the necessary work in hand forthwith and that application be made to the County Council for approval to the expenditure.

8.—STAND-PIPE BASES—DECONTAMINATION:

The Borough Engineer asked for authority to purchase seven bases for stand-pipes for hydrants at 10/- each, which are required for training purposes, and pointed out that it would be practically impossible to obtain an adequate supply in time of emergency.

RESOLVED TO RECOMMEND—That the Borough Engineer be authorised to purchase seven bases for stand-pipes for hydrants at 10/- each.

9.—EMERGENCY HOSPITAL SCHEME:

The Medical Officer of Health submitted a statement showing the staff who had been allocated to the Isolation Hospital in the event of an emergency. In addition to the Medical Superintendent, the staff includes a Deputy Medical Superintendent, four Surgeons, two Assistants, three Anæsthetists, one Radiologist, one Physician, one Medical Officer and three dressers for blood transfusion and auxiliary medical teams.

10.—MEDICAL SERVICES PERSONNEL:

(A).

Lectures.

The Medical Officer of Health reported that since January last, 184 lectures in First Aid and 80 lectures in anti-gas measures have been given to volunteers in the Medical Services organisation. In addition, courses in the elements of First Aid have been arranged for Air Raid Wardens, and 33 classes are now proceeding. The Medical

Messengers:—

War establishment and reserves	112
Enrolled to date	60
In training	60

(c) Miscellaneous Service:—

Enrolments to date	294
--------------------	-------	-------	-------	-------	-------	-------	-------	-------	-----

13.—NATIONAL SERVICE RALLY—HYDE PARK:

It was reported that an intimation had been received to the effect that the strength of the contingent which this authority is to send to the National Service Rally to be held in Hyde Park on Sunday, the 2nd July next, is 48. The Air Raid Precautions Officer reported that arrangements are in hand for a contingent representative of all services to attend the Rally. **Noted.**

14.—INSTRUCTION TO THE PUBLIC:

The Air Raid Precautions Officer reported that arrangements are now complete for the public to be trained in the precautions to be taken against air raids and in what to do during a raid, and such training will be carried out in properly organised classes. Full publicity will be given by means of the press, posters, cinemas, etc., and information will also be conveyed to ratepayers and political associations. The subjects which will be dealt with are:—

- (a) War Gases and their effects.
- (b) What to do if contaminated.
- (c) Precautions to be taken against War Gases (including an inspection of a demonstration Gas Proof Room and an opportunity to wear the Civil Respirator in the Gas Chamber).
- (d) Precautions to be taken against High Explosive Bombs (including an inspection of a demonstration garden trench, Anderson shelter and the correct method of sandbagging).
- (e) Precautions to be taken against incendiary bombs and the method of dealing with this type of bomb (including a demonstration).
- (f) Outline of A.R.P. organisation generally.

15.—ORGANISATION IN FACTORIES AND COMMERCIAL HOUSES AND TRAINING OF EMPLOYEES:

Every assistance is being given to factories and commercial houses to enable them to comply with the provisions of the Civil Defence Bill in regard to air raid routine and the training of employees, and the Air Raid Precautions Officer reported that six firms have already been assisted.

16.—NATIONAL SERVICE DEMONSTRATION:

With reference to the proposed National Service Demonstration referred to in Item 21 (i) of Report (No. 1) of the Committee of the 16th May last, the Air Raid Precautions Officer reported that the Royal Air Force are unable to take part on the date suggested, namely, the 20th July next, and in these circumstances the Committee have agreed to the demonstration being postponed to a date in September next to be arranged.

17.—GOVERNMENT EVACUATION SCHEME:

In Item 1 of Report (No. 2) of the Committee, it is stated that an enquiry had been addressed to the Minister of Health as to whether Hendon is one of the areas on the borders of the Metropolitan Evacuation Area to be included in the review. The Town Clerk has now reported a letter from the Ministry of Health intimating that the Borough of Hendon is not among the areas to be included in the review of the classification of certain Local Government Areas. **Noted.**

18.—WOMEN'S VOLUNTARY SERVICES FOR CIVIL DEFENCE:

In June last, the Secretary of State, Home Office, approved the formation of the Women's Voluntary Services for Civil Defence, the primary purpose of the organisation being to assist and co-operate with local authorities in the enrolment of women for A.R.P. Services, and for the expansion of hospital services which would be necessary if an emergency arose. The Secretary of State is prepared to agree that reasonable expenditure properly incurred by the local authority in connection with the provision of accommodation and equipment for the organisation should be allowed to rank for A.R.P. grant.

The Town Clerk reported that the Women's Voluntary Services for Civil Defence have agreed to establish a centre in Hendon with a view to the stimulation of the recruitment of women in the A.R.P. organisation and other services, and they have requested the Council to provide the requisite accommodation and office furniture. Suitable accommodation cannot be found in any of the Council's existing buildings, and with the approval of His Worship the Mayor and of the Middlesex County Council, arrangements have been made to take over Burroughs House, subject to the existing facilities accorded to Mrs. Dangerfield on behalf of the Personal Service League, at a rent of £1 0s. 0d. per week. This rent has been approved by the County Council, and also an expenditure of a sum not exceeding £10 for the provision of necessary office furniture. Mrs. Lesty of Mill Hill has been appointed by the Women's Voluntary Services for Civil Defence as their representative, and she will be assisted by Mrs. H. R. S. Cameron and Mrs. Billings.

RESOLVED TO RECOMMEND—That the action taken be approved.

19.—PROTECTION OF PETROL DEPOTS AND PETROL FILLING STATIONS:

The Town Clerk reported that a letter had been received from the Secretary of State, Home Office, transmitting for information a memorandum on some of the measures which can be taken at inland bulk or distributing depôts and petrol filling stations with the object of minimising the dangers to life and surrounding property in the event of air attack, and that a copy of the memorandum, which is of a technical character, had been passed to the Chief Officer of the Fire Brigade with a request to take such action on the lines of the memorandum as may be considered necessary. **Noted.**

20.—CO-OPERATION WITH THE CHURCHES IN RELATION TO AIR RAID PRECAUTIONS:

Home Office (A.R.P. Department) Circular No. 119/1939 was submitted stating that the Lord Privy Seal had recently had under consideration the position of Ministers of Religion in times of war, and that he was in entire agreement with the view put forward by the representatives of the Churches, that having regard to the need of maintaining the spiritual ministrations of the churches in time of war, Ministers of Religion and others whose services may be essential for this purpose should not regard it as incumbent upon them to undertake obligations for whole-time national service in war, except as Chaplains in the fighting services. He also recognised the desirability of permitting those Ministers of Religion of all denominations who desire to do so, to move about in the streets under air raid conditions so far as may be practicable so that they may minister to those in need. It is intended to authorise the wearing by all Ministers of

Religion of a distinctive armlet, the design of which is at present under consideration in order to facilitate their recognition under all conditions. The Lord Privy Seal considers that Ministers of Religion should not be attached to any of the Local Authority's Air Raid Precautions Services, but it would be necessary for them to carry out their work in time of emergency in close co-operation and consultation with those services in a spirit of mutual assistance, and to this end the Lord Privy Seal considers it is important that Ministers of Religion should have some training in air raid precautionary measures and that the question of the proportion of Ministers of Religion to receive training is a matter for the judgment of the Church authorities in the various denominations, or for the discretion of the individual Ministers.

The Lord Privy Seal would be glad if Local Authorities would arrange on requests being received to give facilities for recognised Ministers of Religion of any denomination or order to attend ordinary courses of training organised for members of the Local Authority's Air Raid Precautions service, and indicates the nature of the course which should be given. If, however, the Local Authority should find it more convenient to arrange a special lecture, or special course of lectures for Ministers of Religion, the Lord Privy Seal would have no objection to this procedure. The Lord Privy Seal also emphasises the desirability of close co-operation between Local Authorities and the Churches on all matters concerning the plans to be made by the Churches to meet the event of war, *e.g.*, the protection of valuable or historical buildings or possessions, and that Local Authorities should be ready to give on request any advice or assistance in their power to the Churches in these matters.

The letter also points out that it is not intended that buildings regularly used for religious worship should be used for Air Raid Precautions purposes and Local Authorities should not make any use for this purpose of such buildings or designate them for use in war time without the full agreement of the authorities responsible for them.

RESOLVED TO RECOMMEND—That the matter be referred to the Air Raid Precautions Officer to take any necessary action in connection therewith.

21.—APPOINTMENT OF CHIEF AIR RAID WARDEN:

A letter was submitted from the Conference of Ratepayers' Associations of Hendon expressing the apprehension of the delegates to the Conference at the Council's decision to defer the appointment of a Chief Air Raid Warden for three months and delegate the duties to the Air Raid Precautions Officer, and suggesting that the Air Raid Precautions Officer's duties will require all his energy without the extra burden of the Chief Warden's. In view of the urgency of the matter it was requested that the appointment should be made without further delay.

RESOLVED TO RECOMMEND—

- (a) **That the Conference of Ratepayers' Associations of Hendon be informed that their communication has been duly noted and that the matter is receiving attention.**
- (b) **That the Air Raid Precautions Officer be instructed to report on the matter at the next meeting of the Committee.**

22.—AIR RAID PRECAUTIONS OFFICER:

The Town Clerk submitted a letter from the Home Office (Air Raid Precautions Department) in relation to the retention by the Council on the outbreak of hostilities, of the services of Captain Smith, the Air Raid Precautions Officer, who is a voluntary member of the regular army reserve of officers and consequently is at liberty to free himself from his military obligations by resignation.

The Committee understand that Captain Smith is in communication with the War Office and that he will report on the matter to the next meeting.

23.—AIR RAID PRECAUTIONS—ADMINISTRATION, ETC.:

The Committee have received and considered the report of the Town Clerk on the reference to him of the 16th May. (Mayor's—Whitsun—Recess Report, 9/12/39—2 (A) (1) (f)).

In his report the Town Clerk calls attention to extracts from the Home Office A.R.P. Circular No. 9 of the 26th January, 1939, which are in the following terms:—

“4.—The measures of Air Raid Precautions prescribed by the Regulations affect all the main Departments of a Local Authority, and the operation of the scheme in war would require the co-operation of all those Departments. Each Department must therefore fit itself in peace to undertake the duties which would be its concern. While it is proper that a general oversight of the work should be undertaken by a Special Committee of the Council, it is important that Air Raid Precautions should not be treated as a matter extraneous to the ordinary functions of Local Government. Every responsible Officer of a Local Authority, *e.g.*, Medical Officer of Health and Surveyor or Engineer, should be assigned his specific part in the work, and in view of its urgency should be given as much authority on matters of detail as is consistent with the general control by the Local Authority.

5.—A Chief Officer should be put in the position of General Co-ordinating Officer for the preparation of the Council's Air Raid General Precautions Scheme. If an Air Raid Precautions Officer has been specially appointed, he should be regarded as the assistant or staff officer of the Co-ordinating Officer, and should not attempt to assume control, or to relieve the Officers in charge of the various Departments of their Departmental responsibility to the Authority. The Air Raid Precautions Officers who have been specially appointed in many areas have done invaluable work and the Lord Privy Seal has reason to appreciate their services. They are of particular importance in relation to the enrolment and training of volunteers and for the instruction and advice of the public and in ensuring inter-departmental co-ordination; and Sir John Anderson is anxious that their status in these respects should be maintained. But in some areas it has been evident that too much has been left to a specially appointed Air Raid Precautions Officer, this giving the impression that the statutory duty of preparing and submitting Air Raid Precautions schemes is one with which the ordinary machinery of Local Government is not fully concerned. Such an impression produces the result that this machinery is not fully used.”

The report also shows that the system of administration which prevails in Middlesex is that the Town Clerk carries out the duties of Co-ordinating Officer, and Controller, and in conformity with the usual practice, all communications from Government Departments and the County Council on matters of principle are addressed to and dealt with by the Town Clerk who also conveys all decisions of the Council to the various bodies concerned.

The dual title of Co-ordinating Officer and Controller envisages the appointed officer acting in the former capacity in peace time for the co-ordination of all air raid precautions services to ensure that the numerous sections dovetail into one another and that the completed scheme will properly function in a war emergency. The Controller acts only in a war emergency and his post is at the Central Control Centre. He must, of course, have a complete knowledge of the whole organisation and in an emergency may have to act on his own initiative.

The Committee are satisfied that in an emergency the services of the Town Clerk will be required elsewhere than at the Control Centre and they accordingly propose that the Air Raid Precautions Officer shall be designated to act as Controller in such an emergency.

In view of the decentralisation of the various services which prevails in Hendon it is essential that the Air Raid Precautions Officer shall be in close touch with the training and operation of those services under the control of other Departments, and in order to maintain the closest possible contact the Air Raid Precautions Officer will also act as Deputy Co-ordinating Officer, which will provide the necessary inter-departmental contact and facilitate the completion and operation of the Air Raid Precautions scheme as a whole. As a further means to secure the closest relationship between the several Departments and services, periodical meetings of the responsible officers are to be arranged.

The report provides for the transfer of the staff engaged on Air Raid Precautions work in the Town Clerk's Department to the department of the Air Raid Precautions Officer at Ravensfield. The Committee work will be carried out in the same manner as operates in relation to all other Committees of the Council.

After careful consideration of the whole problem of future administration and organisation of the air raid precautions services, the Committee

RECOMMEND—That the organisation shown in the following diagrams be approved and adopted:—

**General Co-ordinating Officer
(Town Clerk)**

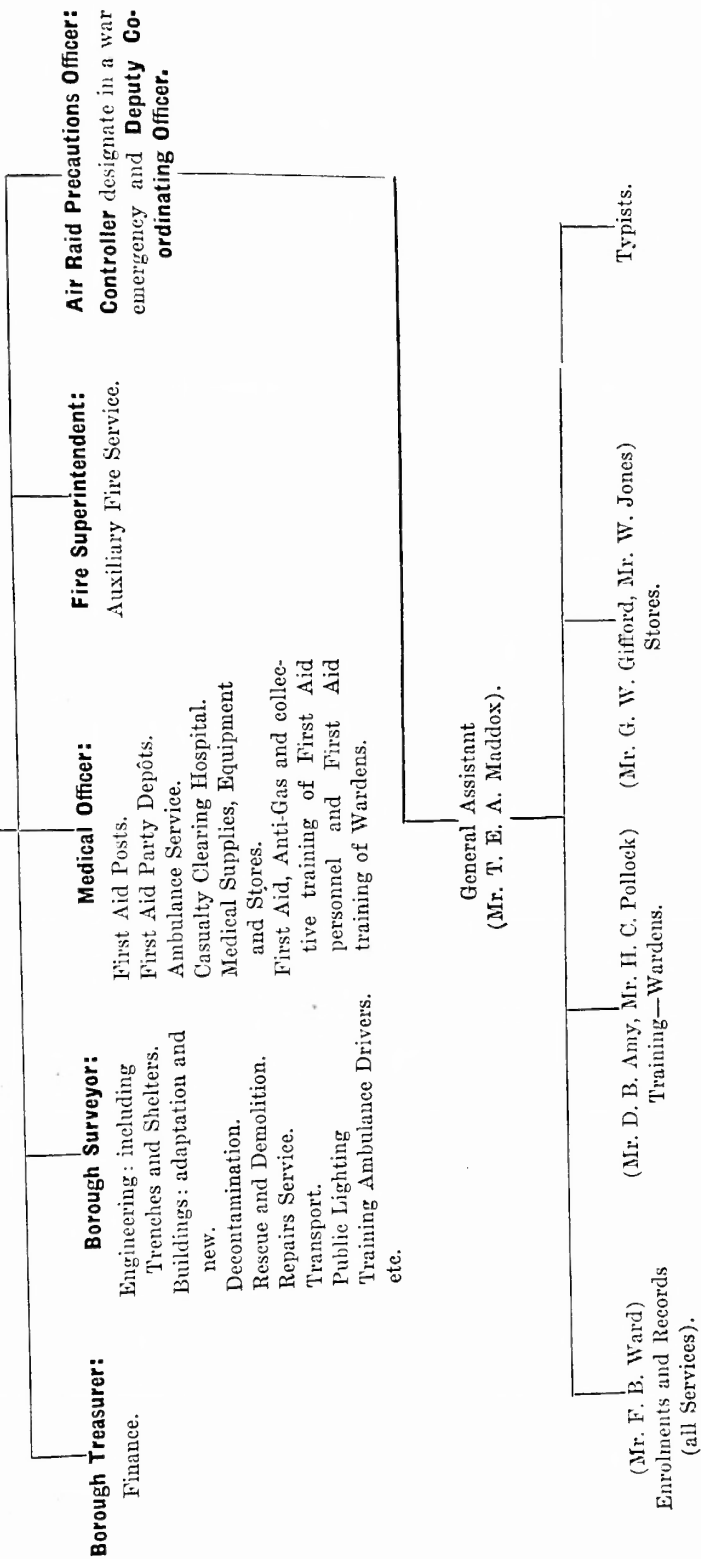
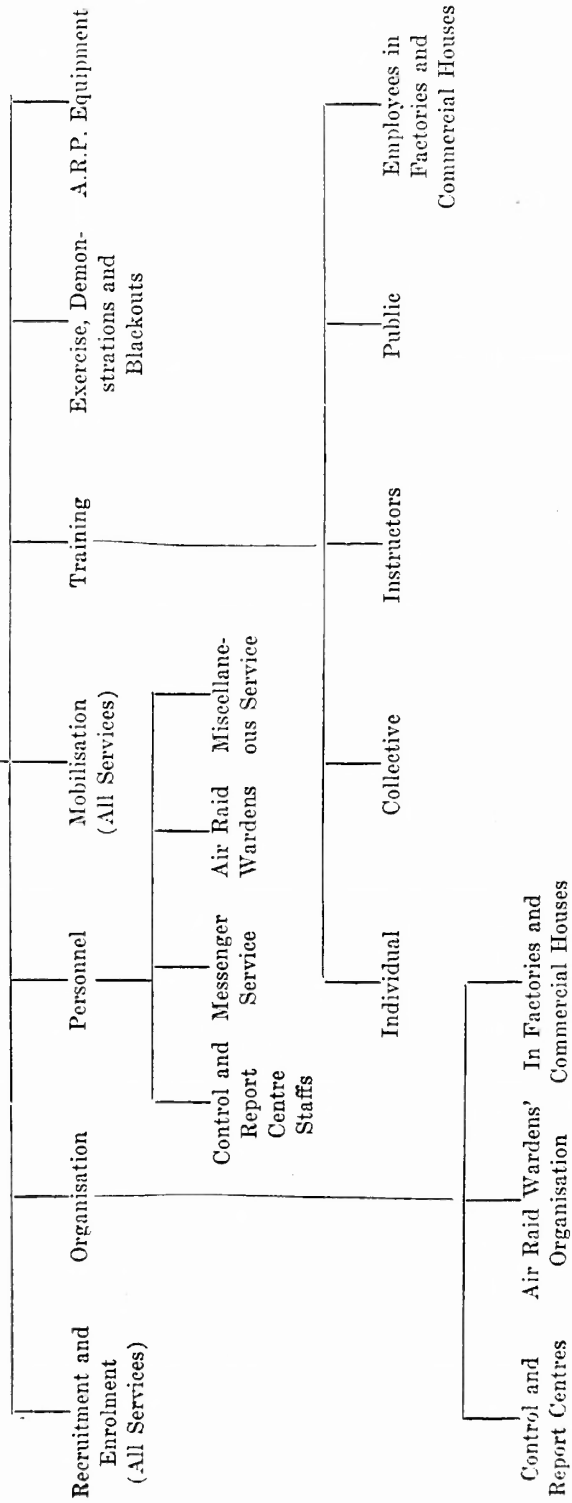

Diagram showing the items which it is suggested should be dealt with by the Air Raid Precautions Department.



Report of the Finance and General Purposes Committee.

12th June, 1939.

COMMITTEE:

Alderman W. R. Clemens, F.C.A. (*Chairman*).

Aldermen:

*J. J. Copestake, J.P.,

S. H. Egan, J.P.

B. Flowers,

(*Deputy Mayor*),

Councillors:

*E. Arter, M.C., M.I.A.E.,

*L. Hirshfield,

*G. R. Richardson,

*F. J. Collins,

*P. Lightfoot,

T. J. Scott,

*A. W. Curton,

*A. A. Naar, M.B.E.,

*W. H. N. Shakespeare,

*F. W. Gilpin,

*C. Pinkney,

M.C., A.F.C., J.P.

*G. H. Hignett,

*H. G. Potter, J.P., F.S.I.

H. P. Small,

(*Mayor*),

• denotes Member present.

His Worship the Mayor (Councillor H. G. Potter, J.P.) in the Chair.

1.—CASH STATEMENT:

The Financial and Statistical Appendix has been examined by Councillor G. H. Hignett, who reported as follows:—

STATEMENT OF RECEIPTS, PAYMENTS AND BALANCES:

1st April, 1939, to 30th April, 1939.

		£	s.	d.
Commencing Balance		116376	4	2
Less 1938/39 Cheques since issued		665	15	4
		115710 8 10		
Receipts (Appendix, page 1):—				
Now Reported		98151	2	4
		213861 11 2		
Payments (Appendix, page 2):—				
Now Reported	£	65953	3	8
Less Cheques Cancelled	s.	500	0	0
		65453 3 8		
Balance at 30th April, 1939 (Appendix, page 3)		£148408 7 6		

2.—RATE COLLECTION ACCOUNT (Appendix, page 4):

Rate Collection 1st April, 1939, to 30th April, 1939.

	Arrears of Rates and Costs.	Current Rate.	Total.
Now reported	£2544 19 3	£34353 13 4	£36898 12 7

3.—STATEMENT OF EXPENDITURE AND INCOME ON RATE FUND ACCOUNTS
(Appendix, pages 5/6):

The Borough Treasurer submitted a Statement of Expenditure and Income for the period from 1st April, 1939, to 30th April, 1939.

4.—ACCOUNTS EXAMINED AND APPROVED FOR PAYMENT (Appendix, page 7):

List of Accounts Submitted to Rota.

REPORTED: That pursuant to the Finance and General Purposes Committee Instruction No. 2 and Resolutions of the Council, the following accounts as listed in the Expenditure Journal had been examined and approved; that in view of the urgency of such accounts the necessary Pay Orders had been prepared and signed as authority to the Borough Treasurer to draw cheques, and that copies of such Pay Orders had been forwarded to the Corporation's Bankers with instructions to honour only such cheques as appeared in such Pay Orders:—

List No.	Date Examined.	Examined by.	General A/c.		Loans Pool.	
			£	s. d.	£	s. d.
—	Previously Reported (Per Minutes, page 711)	—	65921	9 3	31 14	5
	Per Bank Account (Appendix, page 3)	—	£65953		3 8	
—	Previously Reported (Per Minutes, page 711)	—	8498	12 1	—	—
10	8th May, 1939	(Councillor G. R. Richardson)	3301	18 9	—	—
11	8th May, 1939	(Councillor G. R. Richardson)	277	13 8	—	—
275—279	8th May, 1939	(Councillor G. R. Richardson)	3556	8 3	—	—
280	9th May, 1939	(Councillor G. R. Richardson)	681	17 0	—	—
282—284	15th May, 1939	(Alderman Brook Flowers)	2340	8 10	—	—
12—13	16th May, 1939	(Councillor F. J. Collins)	32997	19 1	—	—
285—287	22nd May, 1939	(Councillor F. W. Gilpin)	1575	14 4	—	—
14—17	22nd May, 1939	(Councillor F. W. Gilpin)	74976	3 3	—	—
18	22nd May, 1939	(Councillor F. W. Gilpin)	527	9 5	—	—
19	22nd May, 1939	(Councillor F. W. Gilpin)	—	—	601 18	11
20—23	2nd June, 1939	The Mayor (Councillor H. G. Potter)	7613	12 9	—	—
288—291	6th June, 1939	The Mayor (Councillor H. G. Potter)	3855	18 1	—	—
24—27	12th June, 1939	(Councillor G. H. Hignett)	5604	4 3	—	—
292—295	12th June, 1939	(Councillor G. H. Hignett)	16717	11 6	—	—
			£162525		11 3	601 18 11

Noted.

5.—STATISTICAL RETURNS:

Statistical returns, details of which appear in the appendix to this Report, were submitted and **noted**.

6.—REQUISITIONS:

The following requisitions were submitted and **approved**:—

							£	s.	d.
Town Clerk's Department	11	5	0
General Stationery	257	9	0

7.—LOAN SANCTION:

It was reported that the Minister of Health had issued the following loan sanction:—

Date.	Amount. £	Purpose.	Period. Years.
3/5/39	6,578	Cricklewood Lane Improvement (between Claremont Road and Cricklewood Lane)	20

RESOLVED TO RECOMMEND—That the Borough Treasurer be authorised to raise a loan against such sanction as and when required.

STAFF.

8.—ABSENCE OF STAFF:

It was reported that 7 members of the staff had been absent owing to illness since the last meeting of the Committee. **Noted.**

9.—INCREMENTS:

The Committee have considered the recommendations of the Chief Officers in cases due for scale increments for the period to the 1st July next, together with information as to service, grade, present salary and the amount of increment due according to scale.

RESOLVED TO RECOMMEND—That scale increments be awarded in all cases recommended by the Chief Officers and enumerated in the Borough Treasurer's report.

10.—BOROUGH TREASURER'S DEPARTMENT (HOUSING):

Examination Successes.

It has been reported that Miss P. E. Wardle and Miss O. F. Blott, both of the Housing Department, had passed the final examination of the Chartered Surveyors' Institute.

RESOLVED TO RECOMMEND—That Miss P. E. Wardle and Miss O. F. Blott be granted one additional scale increment.

(Miss P. E. Wardle is now at a fixed maximum and the proposal will have the effect of increasing the maximum of her post from £340 to £360 per annum).

11.—BOROUGH SURVEYOR'S DEPARTMENT:

Junior Engineering Assistants.

(i). Messrs. G. F. N. Clarke and A. Watson, Junior Assistants in the above Department, attain the age of 18 years on the 10th June and 10th July respectively, and on the report of the Borough Surveyor the Committee

RECOMMEND—That Messrs. G. F. N. Clarke and A. Watson be appointed to the permanent staff as from the dates mentioned above at salary according to scale, subject to the production of satisfactory medical reports.

Outdoor Staff.

(ii). A report was submitted as to six employees who will complete a period of twelve weeks sick pay allowed under the regulations (F. & G.P.C., 20/3/39—13).

RESOLVED TO RECOMMEND—That in the five cases referred to in the Borough Surveyor's report an intimation be given that they will be re-instated in their previous employment on production of satisfactory medical certificates, and that the sixth case (A.E.B.) be required to undergo medical examination to establish the possibility of his return to work.

(In the event of A.E.B. being found unfit for further employment the necessary action will be taken to place him on the allowance list under the Superannuation Act, 1937).

12.—MILITARY TRAINING ACT, 1939:

The Committee have had under consideration the recommendation of the Libraries Committee (22/5/39—5) regarding the engagement of temporary employees on members of the staff being called up for training under the above Act.

The matter will, no doubt, affect several of the Committees of the Council, and as a general principle the Committee

RECOMMEND—That authority be given for the engagement of substitutes for a definite period to coincide as far as possible with the period of absence of members of the staff called up for training under the Military Training Act, 1939.

13.—NATIONAL SERVICE—LOCAL GOVERNMENT OFFICERS:

On the 27th February last the Council (F. & G.P.C., 20/2/39—12) authorised Chief Officers to grant consents in writing to Officers not included in the schedule of reserved occupations to undertake voluntary National Service. At that time members of the executive and clerical staff of the age of 25 and over were restricted, and it was subsequently reported (F. & G.P.C., 1/5/39—11) that 76 employees had obligations in respect of National Service as follows:—

Regular Forces, Reserves	—	—	—	—	—	—	—	31
Territorial Force	—	—	—	—	—	—	—	13
Voluntary Services	—	—	—	—	—	—	—	32

A communication, Circular 1817, dated 10/5/39, has since been received from the Ministry of Health calling attention to the revision of the schedule of reserved occupations, and such reservation is now appropriate only to those members of the staff in possession of professional or technical qualifications. All other employees are therefore eligible for recruitment, and the Minister expresses the hope that the Council will give consent freely to enrolment in the case of employees engaged in ordinary clerical duties. In the case of Officers over 25 years of age, engaged on higher executive or administrative duties, whose replacement would be difficult, or whose enrolment in any capacity would interfere with the full performance of duties to the Council in time of war, it is suggested that they should first obtain permission in writing of the Council. When dealing with such applications the Council are asked to consider the extent to which their various services are likely to be expanded or curtailed in time of war and whether the applicants could be dispensed with or replaced if withdrawn from the Council's service or became available only for part-time work.

The Minister of Health by Circular 1827, dated 2/6/39, also calls attention to the following Question and Answer in the House of Commons on the 25th May and adds "that there would be advantage if the principles of those arrangements in so far as they are applicable, were followed by Local Authorities in relation to their employees."

Question.

Mr. McEntee.

Asked the Financial Secretary to the Treasury whether he is aware that many Local Authorities and private firms are considering what payment they will make to Territorials and militiamen who are called up for service or training; and, as they will be guided largely by Government policy, will he state whether it is proposed to pay to permanent Civil Servants, to temporary Civil Servants, and to permanent and temporary industrial workers in Government establishments, the difference between the value of their service pay and allowances and their normal weekly salary or wage in the Civil Service or Government establishment?

Answer.

Captain Crookshank.

Generally, the arrangements will be as follows. All Civil Servants called up for service in accordance with the provisions of the Reserve and Auxiliary Forces Bill will be allowed for the whole period of absence the balance of their civil pay to bring up their total emoluments, service and civil, to the level of their civil pay. Subject to the exigencies of the public service, their position in the matter of their normal leave allowance will be unaffected.

In the case of Civil Servants called up for military training under the Military Training Bill the period of absence will reckon for purposes of increment and superannuation but there will be no issue of civil pay in respect of this period.

The necessary detailed instructions, which will include the bases of assessment of the various emoluments, will be promulgated at an early date and I will send a copy of them to the Hon. Member.

It is not intended by the Order in Council to be made under the Military Training Act, 1939, to authorise payments by Local Authorities to the employees in respect of their period of training. The Act, however, requires the reinstatement of employees on the termination of the training period under conditions not less favourable to the employees than those which would have been applicable to them had they not been called up, and in order to give effect to this requirement Local Authorities should take the period of training into account for the purposes of increment.

It is intended by an Order in Council to be made under the Reserve and Auxiliary Forces Act, 1939, to give power to Local Authorities to allow, for the whole period of absence, the balance of civil pay so as to bring up the total emoluments, service and civil, to the level of the civil pay, and the period of absence should be taken into account for purposes of increment in the same way as the period of training under the Military Training Act.

The Orders in Council to be made under the two Acts of 1939 referred to above will also make provision as to the superannuation position of employees.

The Council by resolution of the 27th January, 1936 (F. & G.P.C., 20/1/36—24) gave full facilities to Territorial members of the staff for attending annual training in camp without penalisation as to holidays and pay, and by resolution of the 10th October, 1938 (F. & G.P.C., 3/10/38—10) authorised full salary, less service pay, not exceeding one month, in respect of members of the staff who had been called up at the crisis.

A communication has been received from the Hendon Branch N.A.L.G.O. intimating that the members are anxious to play their part in National Service and Civil Defence and asking the Council to clarify the position of Officers, particularly those who are likely to be retained by the Council on any specific services. The view is expressed that certain Officers may find themselves, in a war emergency, conscripted to any Unit, and it is felt that it would be preferable to have the option of choosing the Unit now.

The Officers also enquire whether an indication can be given as to the members of the staff who would be retained for specific duties with the Council and as to the duties to which such Officers would be allocated.

The following communication has also been received from the Association of Municipal Corporations:—

“

7th June, 1939.

Dear Sir,

I am directed by the General Purposes Committee to inform you that the Association have been asked to advise as to the course which should be adopted in reference to employees who volunteer or are called up for service with His Majesty's Forces, and that the Committee having conferred with representatives of the County Councils' Association, the Urban and Rural District Councils' Associations and the London County Council decided to advise the members of the Association to adopt the following policy in dealing with such of their employees, including all teachers, as volunteer or are called up for service with His Majesty's Forces during an emergency:—

- (A) To grant leave of absence so that employees may be enabled to serve in the Forces or in civil defence during an emergency;
- (B) To make up the difference between their service pay and allowances and that which they would have received had they remained in the actual service of the authority;
- (C) To safeguard, subject to the passing of such legislation as may be necessary and to the payment of proper contributions, all superannuation rights, including the reckoning of emergency service for superannuation purposes;
- (D) To give such assurances as they can with regard to the reinstatement of employees in their original employment;
- (E) To effect such reinstatement at the points in their respective grades which they would have reached had their service with the authority been uninterrupted;
- (F) To pay salary increments as they fall due.

I am to add that these recommendations do not apply to men called up under the Military Training Act, 1939, or the Reserve and Auxiliary Forces Act, 1939, in reference to whom the Ministry of Health issued a circular on the 2nd instant (circular 1827).

Yours faithfully,

(Signed) HARRY G. PRITCHARD,

The Town Clerk.

Secretary.”

The two Acts and Circular 1827 referred to in the last paragraph of the letter are dealt with in the foregoing report, and the position with regard to men called up for service under the Reserve and Auxiliary Forces Act is covered by the recommendations hereunder. As regards employees called up for training under the Military Training Act, it is clear that no question of any payment during training arises. Re-instatement is compulsory on completion of training, and it is proposed to count the training period for increment and superannuation.

In order that the members of the staff may be aware of their position, the Committee

RECOMMEND—

- (1) That, where possible, members of the staff under 25 years of age and those over 25 years of age on routine clerical duties, excluded from the schedule of reserved occupations, be permitted to volunteer for service with the Territorials or other Reserve Forces of the Crown and/or Civil Defence Services, provided that the consent of the Chief Officer of the Department concerned be first obtained;
- (2) That in the case of an officer over 25 years, excluded from the schedule of reserved occupations, whose enrolment might prove inconvenient to the organisation of any Department, any application for consent to enrol be submitted to the Committee wholly or mainly employing such officer for report to the Finance and General Purposes Committee;
- (3) That any employee (including those referred to in Items 1 and 2 above) who, with the permission of the Chief Officer of his Department and/or the Finance and General Purposes Committee, has become a member of the

Forces of the Crown and/or Civil Defence Services, shall be granted full facilities for attending the annual periods of training without penalisation either as to holidays, pay or increment;

- (4) That any employee to whom Item (3) above applies shall, during any period of absence due to compulsory annual training, be paid his normal civil pay provided that such pay shall be reduced by the amount of any service pay and allowances received;
- (5) That subject to the necessary authority being obtained any employee to whom Item (3) above or the Reserve and Auxiliary Forces Act, 1939, applies, who is called upon for active service with the Forces of the Crown and/or Civil Defence Forces shall, whilst on active service, be paid his normal civil pay less any service pay and allowances received by him during such service;
- (6) That service pay and allowances referred to in Items (4) and (5) above shall not include the value of any board and lodging or any allowance in lieu thereof but shall include allowances for wife and/or dependants.
- (7) That the reference to "employee" in the foregoing items shall be deemed to include all employees of the Council (excluding casual employees) and permanent school teaching staff;
- (8) That in the event of a war emergency or any measure of general compulsory service being introduced the above resolutions shall be applied to all employees to whom permission to join the Forces of the Crown and/or Civil Defence Services has been refused in writing and that as far as any other employee is concerned the application of the resolutions will remain to be considered.

(The Committee have directed the Chief Officers to consider and report on the possibility of selecting Officers to be retained for specific duties with the Council.)

SUPERANNUATION.

14.—TEMPORARY OFFICERS:

The Committee have received a report with regard to certain Officers on the temporary staff to whom the provisions of the Local Government Superannuation Act, 1937, now apply by reason of the completion of two years' service.

RESOLVED TO RECOMMEND—That the following Officers be appointed to the permanent staff:—

Toft, A. A.—Accountancy Assistant, Borough Treasurer's Department—In Grade "D" at his present salary of £245 per annum, to be £255 as from 1st April, 1940.

Golding, R. C. N.—Architectural Assistant, Borough Surveyor's Department—In Grade B.1, commencing at £364 per annum, to be £380 as from 1st November, 1939.

There are other members of the temporary staff employed who have not, as yet, had two years' service and in respect of whom it is not proposed to make any recommendation at present.

15.—SERVANTS:

Lists have been prepared containing the names of approximately 100 employees on the weekly staff who may in due course be placed on the permanent staff and thus become eligible to contribute to the superannuation fund provided they satisfy the conditions of the Council's resolution (F. & G.P.C., 20/2/39 — 14 (i)) relating to Servants Class A.

RESOLVED—That the Borough Treasurer be authorised to take the necessary steps to complete enquiries into the cases referred to and report thereon in due course.

16.—NON-CONTRIBUTORY SERVICE:

The Committee have received and considered an application from the Hendon Branches of the National Association of Local Government Officers and the National Union of Public Employees on behalf of the Workmen for the calculation of non-contributory service for the purpose of superannuation allowances to be based on 60ths in lieu of 80ths.

The Council may grant such allowances, and it is understood that a large number of Local Authorities, including the neighbouring Borough Councils of Wembley, Finchley, Willesden and Hampstead, Ealing and Acton, have agreed that all service shall be reckoned for superannuation purposes at the rate of 60ths.

The Committee are of opinion that the Council should accede to the request of the staff organisations, and accordingly

RECOMMEND—That the basis for the calculation of future superannuation allowances in respect of non-contributory service be now fixed at sixtieths.

17.—REFUND OF CONTRIBUTIONS:

Miss D. M. Watkins, Public Health Department, left the service of the Council, and so far as is known is not entering the service of another Local Authority.

RESOLVED TO RECOMMEND—That authority be given for the refund of contributions to the superannuation fund amounting to £4 14s. 7d. at the expiration of 12 months from 31st May, 1939, or earlier if a claim for payment is made.

18.—TRANSFER VALUE:

A transfer value amounting to £63 9s. 11d. has been received from East Ham County Borough Council in respect of Miss F. Keegan, Deputy Matron at the Isolation Hospital. This payment will entitle Miss Keegan to reckon for superannuation purposes 4 years 7 months non-contributing service and 1 year 1 month contributing service. **Noted.**

19.—ISOLATION HOSPITAL:

The following appointments to the Hospital Staff have taken place as at the dates stated, and are placed on record for the purposes of the superannuation fund:—

Temporary Staff:—

Penfold, Miss	—	—	—	Sister as from 29/5/39.
Lamb, Miss	—	—	—	Staff Nurse as from 18/4/39.
Wood, Miss	—	—	—	Assistant Nurse as from 7/6/39.
Neve, Miss	—	—	—	Probationer as from 7/5/39.

20.—HENDON URBAN DISTRICT COUNCIL ACT, 1929:

It was reported that Mr. C. W. Wingate (Clerk of Works) died on the 3rd November, 1938, and that an enquiry had been made on behalf of the widow as to whether any allowance could be made under the above Act.

Mr. Wingate was employed by the Council from January, 1928, and had had previous Local Government Service with other Authorities amounting to 3 years. He would have become a contributor under the 1937 Superannuation Act and all his Local Government Service amounting to 14 years (approximate) would have ranked for pension as non-contributing service. His salary was £8 per week.

The circumstances of the dependants have been considered, and the Committee

RECOMMEND—That authority be given for periodical allowances to the widow at the rate of 10/- per week, the total amount payable not to exceed a sum of £212 which the Council would have contributed to the superannuation fund in respect of the period of service of Mr. C. W. Wingate, subject to the discontinuation of the allowance in the event of death or re-marriage of the widow.

21.—MIDWIVES ACT, 1936—COMPENSATION:

(i). *Certificate No. 44812—Mrs. L.S.*

This Certificate was surrendered and cancelled by the Central Midwives Board on the 3rd March, 1939. Compensation has been agreed at £180 and a small portion of such compensation may be recoverable from the Willesden Corporation.

RESOLVED TO RECOMMEND—That authority be given for payment of the amount stated.

(ii). *Certificate No. 610616—Miss K.M.N.*

This Certificate was surrendered and cancelled by the Central Midwives Board on the 30th May, 1939. Compensation has not been finally agreed, but the Committee

RECOMMEND—That authority be given to make a payment not exceeding £250.

(iii). *Certificate No. 38453—Mrs. F.B.H.*

This Certificate was surrendered and cancelled by the Central Midwives Board on the 3rd March, 1939. There are certain features of this case which leave the question of compensation in doubt, and the Midwife has been informed that compensation cannot be recommended. This action has been taken mainly with the view to the question of liability for compensation being determined by the Minister of Health on the application of the Midwife. **Noted.**

SMALL DWELLINGS ACQUISITION ACTS.

22.—ADVANCES:

The following application has been disapproved:—

531/R. (R.H.S.)

23.—VACATING RECEIPTS:

The under-mentioned borrowers have indicated their intention of repaying their mortgages:—

Reference.	Principal to be prematurely repaid.		
	£	s.	d.
58/R.1000 (H.W.B.)	68	8	8
61/R.1792 (P.C.A.)	187	10	0
313/R.55595 (S.P.)	437	10	0

RESOLVED TO RECOMMEND—That authority be given for the Corporate Seal to be affixed to the vacating receipts in due course.

24.—PREMATURE REPAYMENT OF ADVANCES:

Since the 1st January, 1939, borrowers have prematurely repaid the balances of their advances amounting to £1,209 9s. 3d.

RESOLVED TO RECOMMEND—That application be made to the Ministry of Health and the Public Works Loan Board for consent to repay the sum of £1,209 9s. 3d., together with any further sums notified on or before the 30th June, 1939, to the Board in reduction of loans outstanding.

25.—RATE OF INTEREST ON ADVANCES:

The rate of interest to be charged on advances is one-quarter per cent. more than the Treasury rate in force one month before the terms of an advance are settled, in respect of loans from the Local Loans Fund for housing purposes. Notification was received that on and after the 1st April, 1939, the Treasury rate for such loans was $3\frac{1}{2}$ per cent and further notification has been received that on and after the 10th May, 1939, the rate is 4 per cent. Therefore the rate of interest on advances made by the Council on and after the 1st May, 1939, was $4\frac{1}{8}$ per cent. and on and after the 10th June, 1939, will be $4\frac{1}{4}$ per cent. **Noted.**

LOANS.

26.—RENEWAL OF LOAN:

Loan No. 265 (Mrs. F. E. R., £500) fell due for repayment on the 27th May, but arrangements have been made for its renewal for a period of 10 years certain at $3\frac{1}{4}$ per cent.

RESOLVED TO RECOMMEND—That the action taken be approved and authority given for any necessary endorsement of the mortgage deed.

27.—NEW LOAN:

With the approval of the Chairman of the Committee, the Borough Treasurer has negotiated loans amounting to £50,000 for a period of 20 years certain at $3\frac{1}{4}$ per cent. £25,000 of the sum mentioned will be obtained from the Sun Life Assurance Company of Canada. The procurement fee in respect of this loan will be 6/3d. per cent., excluding stamp duty, and authority is required to execute the Mortgage Deed in due course.

RESOLVED TO RECOMMEND—That the action taken be approved and that the Corporate Seal be affixed to the mortgages in due course.

PRIVATE STREET IMPROVEMENTS.

28.—AGREEMENTS:

54 agreements, representing 54 apportionments, to pay private improvement expenses by instalments have been completed since the last meeting.

29.—ABERCORN ROAD:

In connection with the service of demand notes for road making charges, the owners of certain plots cannot be traced and in accordance with the usual practice the properties concerned have been fenced.

RESOLVED TO RECOMMEND—That authority be given for the letting of the plots in the usual manner for cultivation at a rent of 1/6d. per pole.

30.—PRIVATE WORKS:

The Borough Surveyor submitted the following statement as to agreements for the execution of private works:—

	Date of Agreement. 1939.	Amount of Deposit. £
W. M. Glendinning — Connections, Granville Road	6th May	25
Parfitt & Co.—Crossing, Hoop Lane.....	8th May	30

Noted.

INSURANCES.**31.—INSURANCE CLAIMS:**

The following statement was submitted and noted:—

Third Party, Driving, etc., Accidents:—

No. of cases in hands of Insurance Companies brought forward	15
No. of new cases	29
		44
No. of cases settled or otherwise disposed of	30
		14
Still outstanding	14
Claims paid by Insurance Companies	£21 4 5

Workmen's Compensation Cases:—

No. of cases on books, 1/5/1939	3
No. of new cases	6
		9
No. of cases taken out of compensation or otherwise disposed of	5
		4
No. of cases now under compensation or pending	4

32.—INSURANCE FUND:

It was reported that a fire had occurred at 13, Clitterhouse Road on the 9th May, 1939, and that the estimated cost of re-instating the damage amounted to £1 5s. 0d.

Noted.**33.—INSURANCES (AUXILIARY FIRE SERVICE):**

Medical certificates have been submitted in respect of two volunteers which state (subject to qualification) that the volunteers are fit for the duties involved.

The Committee, whilst appreciating voluntary effort, are of opinion that a good standard of physical fitness is essential.

RESOLVED—That the matter be referred to the Works and Fire Brigade Committee.

CORPORATION LANDS.**34.—CLITTERHOUSE PLAYING FIELDS:**

The Borough Treasurer reported on arrears of rent due from a Club occupying part of the above playing fields, and as to the action taken in the matter.

RESOLVED TO RECOMMEND—That the matter be referred to the Town Clerk for any necessary action and for report to the next meeting.

35.—AIR RAID PRECAUTIONS:

The Borough Treasurer reported that he had been in communication with the County Council regarding the use of Corporation land on which it is proposed to erect certain buildings in connection with air raid precautions. A sandbag store is proposed to be erected on part of the Montrose Open Space and three multi-purpose buildings are proposed to be erected, viz. :—

1. Claremont Road.
2. Hendon Grove.
3. Mill Hill Park.

The practice hitherto adopted by the County Council with other Local Authorities where similar circumstances exist, is to ask the Local Authority to convey to the County Council the site of the proposed buildings without any consideration, the County Council then granting a lease of the site with the buildings to the Local Authority for a long term of years at a rent of 1/- per annum. The lease in such case contains a covenant restricting the user of the premises to civil defence purposes and a proviso that if the building is no longer required for such purposes the Local Authority is entitled to purchase the building at a valuation on a basis to be approved by the appropriate Government Department, it being understood that as no consideration was given by the County Council for the site, nothing would be paid on the re-sale for the value of the site.

It is understood that the Lord Privy Seal has stated quite definitely that where land already in the ownership of any Local Authority is used for civil defence purposes through the medium of the County Council, he is not prepared to allow any payment to be made to the Local Authority for the loss of use of the site.

The Committee are of opinion that:—

- (a) from the financial standpoint the question of sites is of first importance, and it is suggested that the only satisfactory arrangement is to lease the lands to the County Council at appropriate rents under such restrictive covenants as may be advised;
- (b) before any sites are proposed to be utilised for air raid precautions purposes a reference should be made to the appropriate Committee or to the Finance and General Purposes Committee before schemes are submitted to the Middlesex County Council or the Home Office; and
- (c) in view of the policy of the Home Office it would appear generally desirable to provide sites other than on Corporation lands.

The Committee

RECOMMEND—That an intimation be given that the Town Council will be prepared, subject to the consent of the Ministry of Health, to grant leases on Corporation lands for periods and at rentals to be agreed, subject to such restrictive covenants as the circumstances in each case may warrant.

36.—OPEN SPACES—EDGWARE:

In view of the settlement of the financial adjustments relating to the transfer of Edgware under the Hendon Urban District Council Act of 1929, the Committee have considered the desirability of making application to the Middlesex County Council for grants towards the capital costs involved in the acquisition of open spaces in that area, and have

RESOLVED TO RECOMMEND—

- (1) **That application be made to the Middlesex County Council for grants towards the acquisition of Edgwarebury Park, Stonegrove Park, Deacons Hill and Scratchwood (part of);**
- (2) **That any necessary agreement be entered into with the County Council and that the Corporate Seal be affixed thereto.**

37.—LAND AT THE JUNCTION OF PAGE STREET AND GREAT NORTH WAY, HENDON:

The Council will remember that it has been agreed to sell to the Ministry of Transport a plot of land approximately 400 square yards in extent at the junction of these two roads, which the Minister requires to form the entrance to the subway he is to construct. Compensation has been provisionally agreed at the sum of £200, and the Committee

RECOMMEND—That the settlement be approved and that the Corporate Seal be affixed to any necessary documents.

38.—MILL HILL PARK:

The Committee have considered an application from Mr. Douglas Martin relating to the possibility of acquiring a portion of Mill Hill Park adjacent to the Observatory, 150 feet deep by 40 feet in width, for the erection of a hall to be used in connection with a Men's Bible Class.

The land has now been appropriated as Public Open Space, and the Committee

RESOLVED TO RECOMMEND—That Mr. Douglas Martin be informed that the Council regret that they cannot accede to the request.

39.—HENDON GROVE:

The Committee have received a deputation—Sisters Albertina and Dominica—regarding the question of fencing the above property. The deputation submitted that prior to the land being thrown open to the public no trouble existed, and apart from the legal position in the matter it was urged that the Council should consider the moral aspect specially in view of the character of the Institution, St. Joseph's Convent School, where a large number of children attend. The public use of Hendon Grove had given rise to frequent trespass on the Convent property which had resulted in damage to fabric and livestock.

The Committee thanked the deputation for attending, and upon consideration of the representations find that they are unable to make a recommendation in the matter.

40.—PRESERVATION OF RECORDS:

Pending the erection of the building for the preservation of records, the Borough Treasurer has suggested that certain records should be photographed and stored. British Films Ltd. will supply standard negatives of one and a half inches by one inch at the rate of £15 per 1,000 from which photographs could be supplied, and in order that a satisfactory trial of the system may be made, the Committee

RECOMMEND—That the Borough Treasurer be authorised to incur expenditure up to £30.

41.—TYPEWRITERS — MAINTENANCE CONTRACT:

The Committee have considered the question of the renewal of the contract with the Imperial Typewriter Company for the replacement of typewriters, and

RECOMMEND—That notice be given of intention to exchange the typewriters, subject to satisfactory terms being arranged for a further contract.

42.—SUNDAY ENTERTAINMENTS ACT, 1932:

The County Council have asked for the observations of the Council on the application of the Child's Hill and Criklewood Provident Dispensary to be included in the approved list of Charities.

The income and expenditure account of the Dispensary for the year ended 31st December, 1938, discloses a deficiency of £32 9s. 3d. on a total expenditure of £107 16s. 0d. In February, 1938, the Council decided that as a general rule no Charity should be recommended for inclusion in the approved list where the amount distributed for Charity is less than £350 per annum, and therefore the Child's Hill and Criklewood Provident Dispensary cannot be recommended.

RESOLVED TO RECOMMEND—That the County Council be informed accordingly.

43.—GOOD RULE AND GOVERNMENT BYELAW—ROLLER SKATING:

The Committee have received representations alleging the prevalence of roller skating on footpaths throughout the Borough, and have received a report from the Commissioner of Police from which it appears that complaints in the matter have been received during the last 12 months in respect of 10 roads in the district.

RESOLVED TO RECOMMEND—

- (1) **That the Town Council make the following byclaw, and that the Corporate Seal be affixed thereto:—**

ROLLER SKATING.

1. No person shall on any public footway rink or skate on rollers, wheels or other mechanical contrivances to the danger of passengers.
2. Any person offending against the foregoing byelaw shall be liable on summary conviction to a fine not exceeding forty shillings.

- (2) **That notice of the Council's intention to apply for confirmation of the byelaw be issued under Section 250 of the Local Government Act, 1933.**

44.—JOHN SHUTER FOUNDATION:

St. Paul's C.E. School, Mill Hill.

A communication was submitted from the Correspondent of St. Paul's C.E. School calling attention to the approved scheme (5/10/05) relating to the above Charity in which provision is made for the appointment of one Representative Trustee, for a term of 3 years, to be made by the Town Council.

RESOLVED TO RECOMMEND—**That Councillor G. H. Hignett be appointed the Council's Representative Trustee on the above Charity for a period of three years to the 30th June, 1942.**

45.—GAME LICENCES:

It was reported that applications for the renewal of Game Licences had been received as follows:—

S. Pulham & Sons Ltd.	20, Golders Green Road, N.W. 11.
S. Pulham & Sons Ltd., trading as J. S. Newman & Sons	48, The Broadway, Mill Hill, N.W. 7.
R. C. Hammett Ltd.	34, Golders Green Road, N.W. 11.
do.	19, Temple Fortune Parade, N.W. 11.
Pelham Anderson, for and on behalf of Mac Fisheries Ltd	7, Golders Green Road, N.W. 11.
do.	118, Golders Green Road, N.W. 11.
do.	11, Russell Parade, Golders Green Road, N.W. 11.
do.	69, Brent Street, N.W. 4.
do.	210, Station Road, Edgware.
do.	22, The Parade, Vivian Avenue, N.W. 4.
do.	20, The Broadway, Mill Hill, N.W. 7.
do.	153, Hale Lane, Edgware.
do.	28, Temple Fortune Parade, N.W. 11.

Miss Agnes Herbert Smith, trading as Herbert Smith	46, Church Road, N.W. 4.
Waitrose Ltd.	— — — —	18, Golders Green Road, N.W. 11.
Sidney Thomas Samuel Lewis, for and on behalf of Slaters and Bodega Ltd.	120, Brent Street, N.W. 4.
do.	2, Central Circus, Hendon, N.W. 4.
J. Sainsbury Ltd.	3, Golders Green Road, N.W. 11.
do.	101, Golders Green Road, N.W. 11.
do.	79, Brent Street, N.W. 4.
do.	8, Ashbourne Parade, N.W. 11.
do.	15/17, The Broadway, Mill Hill, N.W. 7.
do.	160, The Broadway, Cricklewood, N.W. 2.
do.	208, Station Road, Edgware.
do.	625, Watford Way, Mill Hill, N.W. 7.
Malcolm Stewart McFarlane, for and on behalf of Cope Bros.		33/35, Temple Fortune Parade, N.W. 11.
R. Gunner Ltd.	144, The Broadway, Cricklewood, N.W. 2.
George Henry Seabrook, trading as G. H. Seabrook & Sons	51, Golders Green Road, N.W. 11.
Robert & Farquhar MacLennan, trading as MacLennan Bros.		268, Watford Way, N.W. 4.
Bert Hill, trading as Hills	88, Golders Green Road, N.W. 11.
J. S. Ankerson, trading as Blackistons	174, Cricklewood Broadway, N.W. 2.
Pelham Anderson, for and on behalf of John Duncan & Sons (Liverpool) Ltd.	95, The Broadway, Mill Hill, N.W. 7.
Jeremiah A. Green	13, Church Road, Hendon, N.W. 4.

RESOLVED TO RECOMMEND—That the licences be renewed for a period of one year to the 1st July, 1940, and that the Corporate Seal be affixed thereto.

46.—TRANSPORT—REVISION OF FARES:

Statements issued by the London Passenger Transport Board with regard to the revision of fares have been submitted, and copies have been circulated to all members of the Council.

47.—COUNCIL'S AGENDA:

An application has been submitted from Captain A. G. Petrie, who attends the meetings of the Air Raid Precautions Committee as a representative of the Wardens' Organisation, for copies of the Council's Agenda.

RESOLVED TO RECOMMEND—That all representatives of the various organisations who attend the meetings of the Air Raid Precautions Committee be furnished with copies of the reports of the Committee.

48.—EXPENDITURE—COMMUNITY CENTRES:

The Committee have received and have **noted** a communication from the Conference of Ratepayers' Associations expressing the opinion that in view of the possibility of further increases in the rates, both Local and County expenditure should be curtailed to a minimum commensurate with economy, and that at the present time the provision of Community Centres should be deferred.

APPENDIX

TO

Report of Finance and General Purposes Committee,

12th June, 1939.

Page	
1/2.	Statement of Receipts and Payments.
3.	Statement of Bank Accounts and Balances.
4.	Rate Collection Account and Comparative Statement.
4.	Statement of Rateable Values.
5/6.	Expenditure and Income on Rate Fund Accounts.
7.	Accounts Examined and Approved.
7.	Requisitions submitted to Committees.

Statistical Returns:—

8.	Education Services.
8.	School Medical Services.
9.	Maternity and Child Welfare Services.
9.	Hendon Borough (Nursing Associations) Scheme, 1935.
10.	General Health Statistics.
11.	Fire Brigade and Ambulance.
11.	Refuse Destructor.
11.	Small Dwellings Acquisition Acts.
12.	Housing Statistics.
13/14.	Library Statistics.
15.	Public Parks.
15.	Public Lavatories.
15.	Public Slipper Baths.
16.	Open Air Swimming Baths.
17.	Wages Return.
18.	Loan Debt Statement.
19.	Loan Sanctions.
19.	Payments to Contractors under Engineer's Certificates.
20.	Contracts, etc. let.

1.—RECEIPTS AND
1st April, 1939

RECEIPTS.		£	s.	d.	Receipts now Reported.	£	s.	d.
Revenue Accounts (General).....				55805	11	2	
Private Street Improvements				1632	12	4	
					<u>57438</u>	<u>3</u>	<u>6</u>	
Elementary Education Accounts	19391	6	7				
Higher Education Accounts	673	6	11				
Youth Organisation Accounts	2	15	6				
		<u>20067</u>	<u>9</u>	<u>0</u>				
Capital Accounts (General)	—	—	—				
Capital Accounts (Education)	—	—	—				
Small Dwellings Act Accounts				879	1	9	
Superannuation Fund Accounts				1075	1	10	
Loans Pool Account				10000	0	0	
Receipts 1939/40 Accounts	<u>£89459</u>	<u>16</u>	<u>1</u>				
ARREARS—1938/39.								
Revenue Accounts (General)				8215	4	4	
Private Street Improvements				—	—	—	
Elementary Education Accounts	456	1	6				
Higher Education Accounts	10	4	3				
Youth Organisation Accounts	—	—	—				
		<u>466</u>	<u>5</u>	<u>9</u>				
Capital Accounts (General)	—	—	—				
Capital Accounts (Education)	—	—	—				
Small Dwellings Act Accounts				—	—	—	
Superannuation Fund Accounts				9	16	2	
Loans Pool Account				—	—	—	
Receipts 1938/39 Accounts	<u>£8691</u>	<u>6</u>	<u>8</u>				
TOTAL RECEIPTS	<u>£98151</u>	<u>2</u>	<u>4</u>				
Cancelled Cheques:—								
General Cash Book folio 12				500	0	0	
Nett Balance in Hand, 1st April, 1939:—								
Per General Cash Book folio 12				93638	0	9	
Per Loans Pool Cash Book folio 2				22738	3	5	
		<u>£215027</u>	<u>6</u>	<u>6</u>				

PAYMENTS ACCOUNT.

—31st March, 1940.

PAYMENTS.		£	s.	d.	Payments now Reported.	£	s.	d.
Revenue Accounts (General).....	—				33850	9	1	
Private Street Improvements.....	—				92	2	3	
					<hr/>			
					33942	11	4	
Elementary Education Accounts	—	13084	10	5				
Higher Education Accounts	—	108	11	6				
Youth Organisation Accounts	—	8	14	5				
		<hr/>			13201	16	4	
Capital Accounts (General)	—	8798	6	5				
Capital Accounts (Education)	—	217	7	10				
		<hr/>			9015	14	3	
Small Dwellings Act Accounts	—							
Superannuation Fund Accounts	—				147	0	6	
Loans Pool Account	—				31	14	5	
					<hr/>			
Payments 1939/40 Accounts	—				£56338	16	10	
					<hr/>			
CREDITORS—1938/39.								
Revenue Accounts (General).....	—				6535	4	6	
Private Street Improvements	—				2	9	10	
					<hr/>			
					6537	14	4	
Elementary Education Accounts	—	2279	10	3				
Higher Education Accounts	—	22	18	11				
Youth Organisation Accounts	—	12	2					
		<hr/>			2303	1	4	
Capital Accounts (General)	—	296	6	1				
Capital Accounts (Education)	—	476	15	5				
		<hr/>			773	1	6	
Small Dwellings Act Accounts	—							
Superannuation Fund Accounts	—				9	8		
Loans Pool Account	—							
					<hr/>			
Payments 1938/39 Accounts	—				£9614	6	10	
					<hr/>			
TOTAL PAYMENTS	—				£65953	3	8	
					<hr/>			
Cheques written back:—								
General Cash Book folio 12	—				665	15	4	
					<hr/>			
Nett Balance in Hand, 30th April, 1939:—					148408	7	6	
Per Bank Account page 3	—				<hr/>			
					£215027	6	6	
					<hr/>			

2.—BANK ACCOUNTS AND BALANCES:

RECEIPTS.				PAYMENTS.							
1st April, 1939, to 31st March, 1940.				Balances, 30th April, 1939.							
Balances, 31st March, 1939.		Receipts now reported.		Payments now reported.		Cheques Written Back.		Balances, 30th April, 1939.		Total.	
In Hand.	Overdrawn.	Transfers In.	Cheques not issued and Cancelled Cheques.	£ s. d.	£ s. d.	£ s. d.	£ s. d.	In Hand.	Overdrawn.	£ s. d.	£ s. d.
£ s. d.	£ s. d.	£ s. d.	£ s. d.	£ s. d.	£ s. d.	£ s. d.	£ s. d.	£ s. d.	£ s. d.	£ s. d.	£ s. d.
35550 19 2	— — —	— — —	— — —	65633 7 10	121204 7 0	— — —	— — —	80181 16 1	— — —	— — —	121204 7 0
6888 13 0	— — —	— — —	— — —	20533 14 9	27522 7 9	— — —	— — —	11894 0 0	— — —	— — —	27522 7 9
13203 6 8	— — —	— — —	500 0 0	— — —	14403 6 8	— — —	— — —	4614 10 11	— — —	— — —	14403 6 8
2711 5 10	— — —	— — —	— — —	879 1 9	3580 7 7	— — —	— — —	3590 7 7	— — —	— — —	3590 7 7
14453 16 1	— — —	— — —	— — —	1084 18 0	15568 14 1	— — —	— — —	15421 3 11	— — —	— — —	15568 14 1
33598 0 9	— — —	— — —	500 0 0	88151 2 4	182289 3 1	— — —	— — —	665 15 4	— — —	— — —	182289 3 1
22738 3 5	— — —	— — —	— — —	10000 0 0	32738 3 5	— — —	— — —	32706 9 0	— — —	— — —	32738 3 5
2116376 4 2	— — —	— — —	500 0 0	98151 2 4	215027 6 6	— — —	— — —	665 15 4	— — —	— — —	215027 6 6
				Totals							

BANK RECONCILIATION ACCOUNT.		£	s.	d.
Balance Per Bank Certificate—30th April, 1939	184631	17	8
Deduct:—				
Wages and Urgent Payments Account	3179	0	10
Returned Cheques Account	230	13	2
Bank Charges Account	60	0	0
		350	13	2
		2828	7	8
Less Unpresented Cheques	181803	10	0
		37848	8	2
Add In Hands of Cashier	143955	1	10
		4453	5	8
Balance as above	2148408	7	6

(4)

RATE AND COSTS COLLECTION ACCOUNT—YEAR ENDING 31st MARCH, 1940:
(One Month to 30th April, 1939.)

Debits.	£	s.	d.	Credits.	£	s.	d.
Arrears of Rate, 31st March, 1939	11415	12	0	Cash Collected to 30th April, 1939:—			
Rate made 3rd April, 1939, at 11/0d. in the £	1060999	10	0	Previously Reported			
Government Contribution in lieu of Rates	18230	6	0	Now Reported:—			
Supplementals, to 30th April, 1939				Arrears and Costs	2544	19	3
Rates Costs:—				Current Rates	34353	13	4
Arrears	306	19	0				36898 12 7
Current	2	4	0				36898 12 7
			399 3 0	Balances Due (subject to allowances):—			
				Arrears and Costs	9179	15	9
				Current Rates	1044876	2	8
							1054055 18 5
							£1090954 11 0
							£1090954 11 0

Percentages Collected (including Costs).

Previously Reported	—
Now Reported	3.38%
Percentage of Total Debit	3.38%

Collected to 31st May, 1939:—£149911 5s. 3d.

RATE COLLECTION—COMPARATIVE STATEMENT.

As AT	General Rate 1936-37		General Rate 1937-38		General Rate 1938-39		General Rate 1939-40	
	Collected	Percentage	Collected	Percentage	Collected	Percentage	Collected	Percentage
	£		£		£		£	
30th April	9,266	1.02	25,435	2.69	37,154	3.65	36,843	3.38
31st May	142,920	15.65	145,728	15.39	169,034	16.62		
30th June	291,507	31.89	302,362	31.91	316,287	31.93		
31st July	393,745	40.36	422,860	44.62	445,403	43.67		
31st August	418,227	46.15	442,316	46.59	475,830	46.52		
30th September ..	436,560	47.59	456,989	48.07	488,254	47.65		
31st October	501,552	54.18	544,446	56.97	586,148	57.20		
30th November ..	622,737	67.27	645,117	67.31	690,419	67.14		
31st December ..	731,462	78.56	760,032	79.29	816,788	79.23		
31st January	845,454	90.76	879,876	91.76	936,007	90.73		
28th February ..	870,388	93.25	904,444	94.21	967,249	93.70		
31st March	883,671	94.32	916,339	95.23	981,042	94.93		

STATEMENT OF RATEABLE VALUES.

RATEABLE VALUES.	EDGWARE.		HENDON.		TOTAL.
	£	£	£	£	
UNREDUCED RATEABLE VALUE (excluding Agricultural Land and Farm Buildings).		202713		1820264/4/-	2022977/4/-
Former Rateable Value of Land and Buildings.		452		1848	2300
Total Unreduced Rateable Value.		£203165		£1822112/4/-	£2025277/4/-
REDUCED RATEABLE VALUE.					
GENERAL HEREDITAMENTS.		109541		1739188	1938729
TITHES. Land covered with water, and land used as Railway other than Freight Transport.		417		3612	4029
INDUSTRIAL HEREDITAMENTS.					
Industrial Purposes	373		15886		
Non-Industrial	81	454	6665	22551	23005
FREIGHT TRANSPORT HEREDITAMENTS.					
Running Lines	274		1504		
Station Buildings, etc.	19		284		
Other Land and Buildings		293		1788	2081
Reduced Value 2nd June, 1939.		£200705		£1767139	£1967844
Reduced Value 1st April, 1939.		£199015		£1763221	£1962236
Increase to Date.		£1690		£3918	£5608

Add In Hands of Cashier 4453 5 8
 Balance as above £14810 7 0

STATEMENT OF EXPENDITURE AND

1st April, 1939 to

EXPENDITURE.				Amount now Reported.
				£ s. d.
Parks, Pleasure Grounds and Open Spaces	---	---	---	1842 13 7
General Public Health Services	---	---	---	145 0 10
Hospital, Maternity and Child Welfare, and Midwifery	---	---	---	375 10 3
County and Trunk Roads	---	---	---	1444 7 7
Local Roads	---	---	---	1977 8 10
Public Lighting	---	---	---	17 19 6
Traffic Control	---	---	---	16 4 1
Street Naming	---	---	---	15 18 5
Public Libraries	---	---	---	161 18 4
Town Planning	---	---	---	6 14 7
Public Depôts and Cottages	---	---	---	166 13 6
Sewers	---	---	---	184 2 11
Refuse Removal and Disposal	---	---	---	2214 3 3
Baths and Conveniences	---	---	---	814 12 8
Fire Brigade	---	---	---	848 11 5
Salaries and General Establishment Charges	---	---	---	6934 13 0
Town Hall and Corporation Estates	---	---	---	284 2 6
Dividends and Interest	---	---	---	---
Mayoral Allowances, etc.	---	---	---	43 10 4
Education Rate Contribution	---	---	---	13350 0 0
Precepts of Other Authorities:—				
Middlesex County Council	---	---	---	---
Metropolitan Police	---	---	---	---
Assessment Committee	---	---	---	---
Loan Charges (General)	---	---	---	458 11 0
Stocks and Stores Accounts	---	---	---	40 0 0
Purchase of Vehicles	---	---	---	---
Contributions to Housing Account	---	---	---	---
Purchase of Land and Property	---	---	---	1518 11 7
Air Raid Precautions	---	---	---	612 10 8
Freedom of the Borough	---	---	---	---

				33473 18 10
Balance—Surplus	---	---	---	495496 7 11

 £528970 6 9

INCOME ON RATE FUND ACCOUNTS.

30th April, 1939.

INCOME.	Amount now Reported.
	£ s. d.
Parks, Pleasure Grounds and Open Spaces	485 18 5
General Public Health Services	14 3 6
Hospital and Maternity and Child Welfare	35 15 6
County and Trunk Roads	— — —
Local Roads	— — —
Public Lighting	1 3 0
Traffic Control	— — —
Public Libraries	106 14 10
Town Planning	2 10 0
Public Depôts and Cottages	33 19 10
Sewers and Sewage Disposal	12 13 3
Refuse Removal and Disposal	92 2 8
Baths and Conveniences	102 8 5
Fire Brigade	132 9 10
Salaries and Establishment Charges	309 8 6
Town Hall and Corporation Estates	64 11 7
Dividends and Interest	575 5 7
Loan Charges (General)	— — —
Stocks and Stores Accounts	159 6 11
Air Raid Precautions	2 11 10
	<hr/>
	2131 3 8
General Exchequer Grant—Instalment	14205 0 0
	<hr/>
	£ s. d.
Rate Income (First Instalment)	539614 18 0
Less 5 per cent. for Allowances, Voids, etc.	26980 14 11
	<hr/>
	512634 3 1
Supplementals, etc., to 30th April, 1939	— — —

£528970 6 9

(7)

ACCOUNTS EXAMINED AND APPROVED:

The following orders have been made on the Borough Treasurer for payment of accounts examined and approved in pursuance of Standing Orders and Resolutions of the Council:—

List No.	Date Examined.	Examined by.	General A/c.		Loans Pool.	
			£	s. d.	£	s. d.
—	Previously Reported (Per Minutes, page 711)	—	65921	9 3	31	14 5
	Per Bank Account (Appendix, page 3)	—	£65953	3 8		
<hr/>						
—	Previously Reported (Per Minutes, page 711)	—	8498	12 1	—	—
10	8th May, 1939	(Councillor G. R. Richardson)	3301	18 9	—	—
11	8th May, 1939	(Councillor G. R. Richardson)	277	13 8	—	—
275—279	8th May, 1939	(Councillor G. R. Richardson)	3556	8 3	—	—
280	9th May, 1939	(Councillor G. R. Richardson)	681	17 0	—	—
282—284	15th May, 1939	(Alderman Brook Flowers)	2340	8 10	—	—
12—13	16th May, 1939	(Councillor F. J. Collins)	32997	19 1	—	—
285—287	22nd May, 1939	(Councillor F. W. Gilpin)	1575	14 4	—	—
14—17	22nd May, 1939	(Councillor F. W. Gilpin)	74976	3 3	—	—
18	22nd May, 1939	(Councillor F. W. Gilpin)	527	9 5	—	—
19	22nd May, 1939	(Councillor F. W. Gilpin)	—	—	601	18 11
20—23	2nd June, 1939	The Mayor (Councillor H. G. Potter)	7613	12 9	—	—
288—291	6th June, 1939	The Mayor (Councillor H. G. Potter)	3855	18 1	—	—
24—27	12th June, 1939	(Councillor G. H. Hignett)	5604	4 3	—	—
292—295	12th June, 1939	(Councillor G. H. Hignett)	16717	11 6	—	—
			£162525	11 3	601	18 11

REQUISITIONS SUBMITTED TO COMMITTEES.

	1938-39	Amount Previously Reported	Approved during Recess	SUBMITTED TO COMMITTEE		Total to 1st May, 1939
				Date	Amount	
	£ s. d.	£ s. d.	£ s. d.	1939	£ s. d.	£ s. d.
SUB-COMMITTEES OF THE EDUCATION COMMITTEE.						
School Management	8178 16 7	—	—	—	—	—
Works and General Purposes	3068 17 1	—	—	—	—	—
School Medical Services	647 17 9	—	37 1 11	17th Apr.	48 8 7	85 10 6
Total Education	11895 11 5	—	37 1 11		48 8 7	85 10 6
COMMITTEES OF THE COUNCIL.						
Public Health and Medical Services:—						
Maternity and Child Welfare	2780 14 5	—	—	" "	569 14 1	569 14 1
Public Health	505 18 7	—	52 3 10	" "	—	52 3 10
Isolation Hospital	1145 1 10	—	—	" "	80 15 5	80 15 5
Highways	30735 0 3	—	—	" "	6789 12 10	6789 12 10
Estates, Parks and Allotments	3074 8 5	—	17 13 5	" "	365 17 8	383 11 1
Works and Fire Brigades:—						
Works	15954 3 7	—	106 1 8	24th Apr.	1954 12 11	2060 14 7
Fire Brigade	1952 19 10	—	—	" "	450 15 11	450 15 11
Buildings and Town Planning	2 9 6	—	—	" "	—	—
Libraries:—						
General	4719 10 3	—	111 0 0	" "	543 16 1	654 16 1
Books—Central	697 0 0	—	—	" "	52 0 0	52 0 0
" Golders Green	610 0 0	—	—	" "	50 0 0	50 0 0
" Mill Hill	531 0 0	—	—	" "	43 0 0	43 0 0
" School Libraries	257 11 0	—	—	" "	—	—
Finance and General Purposes:—						
Stationery	3272 0 11	—	219 17 3	1st May	219 9 3	511 6 6
Clerk's Department	171 10 1	—	—	—	—	—
Rating and Valuation	43 6 5	—	—	—	—	—
Air Raid Precautions	1412 18 8	—	30 3 0	—	—	30 3 0
Total Council	67865 13 9	—	536 19 2		11191 14 2	11728 13 4
Total Requisitions	79761 5 2	—	574 1 1		11240 2 0	11814 2 10

EDUCATION SERVICES—School Attendance.

Year ended 31st March	Accommo- dation	NUMBERS ON ROLL		ATTENDANCES	
		At date	Average during year	Average during period	Per- centage
1932 ...	15118	13576	13144	11783	89.6
1933 ...	15298	14131	13971	12340	88.3
1934 ...	14799	14327	14371	12839	89.5
1935 ...	15543	14308	14262	12782	89.6
1936 ...	15943	14258	14340	12820	89.6
1937 ...	15943	14239	14295	12623	88.3
1938 ...	16009	14248	14291	12632	88.3
1939 ...	17269	14322	14181	12753	89.0
Week ended 28th April, 1939	16589	14371	—	13325	92.7

EDUCATION SERVICES—Employment of Children.

DATE		SCHOOL CHILDREN EMPLOYED			EMPLOYMENT CARDS					
Day	Year	Boys	Girls	Total	Issued			Returned		
					Boys	Girls	Total	Boys	Girls	Total
19th April	1932	190	13	203	38	1	39	—	—	8
22nd March	1933	225	14	239	9	—	9	—	—	—
21st March	1934	236	11	247	19	—	19	—	—	—
21st March	1935	360	12	372	23	1	24	3	2	—
20th March	1936	339	17	356	20	—	20	6	—	5
7th April	1937	244	15	259	30	4	34	24	2	6
24th March	1938	353	17	370	38	2	40	8	—	26
22nd March	1939	332	10	342	21	—	21	8	1	9
Period 1939/40										
3rd May	1939	276	10	286	28	1	29	33	1	34

HEALTH SERVICES—School Medical Statistics.

Year ended 31st December	MEDICAL				DENTAL				
	Examinations			Infectious Cases		Attendances at Clinics		Children Examined	Requiring Treatment
	Routine	Special	No of De- fects found	Notifi- cable	Other	Medical	Dental		
1932 ...	5307	8179	3062	165	1680	37232	5896	11795	7020
1933 ...	4921	8989	2871	318	706	36093	6140	9456	4470
1934 ...	3795	7453	2477	496	1172	33001	7507	11898	6739
1935 ...	4709	6846	2531	204	1039	33156	8588	13467	7538
1936 ...	5497	7101	2859	142	1712	38215	13081	9154	6198
1937 ...	4419	7087	1719	155	1054	35576	13782	9509	6055
1938 ...	4457	7717	1679	220	1095	41163	13204	6585	3995
1939									
4 weeks to 28th Jan.	304	490	122	16	40	2477	1190	732	322
4 weeks to 28th Feb.	533	694	211	37	29	3418	1224	603	385
6 weeks to 8th April	731	1113	253	34	56	5088	1517	979	517
4 weeks to 6th May	324	739	121	22	67	2838	937	323	191

HEALTH SERVICES—Maternity & Child Welfare Statistics.
Table I. Attendances for 4 weeks to 6th May, 1939.

Nature of Service	HEALTH CENTRES									
	Central Hendon	West Hendon	Child's Hill	Watling Estate	Mill Hill	Temple Fortune	Edgware	Colindale	Wood-side Park	Total
Maternity—General										
Ante-Natal	38	76	82	59	84	—	—	—	—	—
Children under 5 ...	578	441	750	878	674	230	451	314	166	339
Dental										
Ante-Natal	59	—	37	24	28	—	—	—	—	148
Children under 5 ...	26	—	16	19	21	—	—	—	—	82
Eye										
Children under 5 ...	20	—	—	—	—	—	—	—	—	27
Orthopaedic										
Children under 5 ...	61	—	—	—	—	—	—	—	—	109
Ophthalmia Neonatorum Regulations 1926										
No. of cases to St. Margaret's Hospital	—	—	—	—	—	—	—	—	—	—
Queen Charlotte's "	—	—	—	—	—	—	—	—	—	—
City of London "	—	—	—	—	—	—	—	—	—	—

Table II. General.

Year ended 31st December	MATERNITY CENTRES							Midwives Services		Grants Assisted Milk Supply	
	Number of Centres	SESSIONS					Home Visitations	Cases attended	Visits		
		Number	Child Attendances	Ante Natal Attendances	Total	Average per Session					New Members
1932	6	632	34587	597	35184	57	1444	17087	103	2167	156
1933	7	699	38825	657	39512	57	1552	17933	91	2021	898
1934	7	713	39188	1079	40267	57	1618	16008	113	2401	1229
1935	7	712	41249	1242	42491	59	1784	14150	110	2294	1588
1936	8	767	44521	1692	46029	60	1799	15527	118	2440	1715
1937	8	811	49544	2391	51035	64	1823	14571	110	2555	2091
1938	8/9	942	59535	4288	63823	68	2091	15058	134	3320	3032
1939											
4 weeks to 28th Jan.	9	80	4481	376	4857	61	157	1116	28	585	293
4 weeks to 28th Feb.	9	80	5273	402	5675	71	101	892	15	418	292
6 weeks to 8th April	9	116	7211	645	7856	68	238	1670	29	669	417
4 weeks to 6th May	9	72	4700	487	5187	72	154	1118	16	406	257

HENDON BOROUGH (Nursing Associations) SCHEME, 1935.

Number of cases and visits made on behalf of the Hendon Borough Council (children under 5, and expectant and nursing mothers). Scheme operative from 1st October, 1935.

Disease	Statistics for Period from 1st January to 31st March, 1939															
	Year to 31st Dec., 1937		Year to 31st December, 1938		Edgware and Little Stanmore		Watling		West Hendon and Colindale		Golders Grn. and East Cricklewood		Mill Hill		Totals	
	Cases	Visits	Cases	Visits	Cases	Visits	Cases	Visits	Cases	Visits	Cases	Visits	Cases	Visits	Cases	Visits
Infantile Diseases—																
Notifiable	2	38	5	34	—	—	—	—	—	—	—	—	—	—	—	—
Other	465	2198	518	2249	12	45	59	204	20	204	9	53	3	8	103	514
Maternal Diseases—																
Notifiable	—	—	3	30	—	—	—	—	—	—	—	—	—	—	—	—
Other	30	106	24	153	2	23	—	—	—	—	3	18	1	5	6	46
Diseases—																
Notifiable	—	—	—	—	—	—	—	—	—	—	—	—	—	—	—	—
Other	167	1123	22	176	1	7	13	85	1	4	—	—	4	55	19	151
Poor Law Cases ..	1	10	—	—	—	—	—	—	—	—	—	—	—	—	—	—
Totals	665	3565	572	2612	15	75	72	289	21	208	12	71	8	68	128	711

HEALTH SERVICES—General Health Statistics, Table I.

4 weeks to 6th May, 1939.

REMISSION OF FEES		DISEASES NOTIFIED		SANITATION	
Service	Number of Cases	Name	Number of Cases	Details	Number
Doctor under Midwives Acts	3	Scarlet Fever	25	Inspections, visits and Re-inspections made	1392
Council Midwife	3	Diphtheria	8	Complaints received and investigated ...	111
Provision of Dentures	6	Pulmonary Tuberculosis	9	Preliminary and Statutory notices served... ..	101
Dental Treatment	5	Other Forms Tuberculosis	—	Notices Complied with	96
Maintenance in Hospital for confinement	—	Puerperal Fever	—	Special Drain Tests ...	1
Maintenance in Orthopaedic Hospital	—	Puerperal Pyrexia	5		
Provision of Orthopaedic Appliance	1	Erysipelas	4		
Provision of Spectacles	—	Pneumonia	7		
Tonsillectomy	8	Dysentery	5		
Maintenance in Convalescent Home	—	Food Poisoning	—		
Maintenance at Russell Cotes School	3	Ophthalmia Neonatorum	—		
X-Ray Treatment	—	Typhoid Fever... ..	—		
Accouchement Sets	2	Poliomyelitis	—		
Treatment of Squint	—	Malaria	—		
		Cerebro Spinal Fever..	2		
		Meningitis	—		
Total	31	Total	65		

General Health Statistics, Table II.

Year ended 31st December	POPULATION				Population 30th June	INFECTIOUS DISEASES				
	Births		Deaths			Notifications		Cases removed to Hospital		Cases under Treatment in Hospital at Date
	Adjusted Total	Per 1000	Adjusted Total	Per 1000		Number	Per centage	Hendon	Other	
1932	1688	13.70	1036	8.40	124477	761	6.15	311	133	47
1933	1673	13.11	1013	7.93	129696	1024	7.89	513	125	97
1934	1643	12.53	1065	8.12	138643	1322	9.53	782	117	106
1935	1724	12.85	1146	8.54	146720	896	6.11	515	96	50
1936	1835	13.04	1166	8.29	155800	777	5.0	301	99	53
1937	1674	10.32	1558	9.61	162079	828	5.11	342	87	64
1938	1914	11.63	1506	9.12	165343	1000	6.05	484	87	55
1939										
4 weeks to 28th Jan.	156	—	182	—	—	75	—	16	1	44
4 weeks to 28th Feb.	164	—	154	—	—	76	—	59	3	76
6 weeks to 8th April	240	—	237	—	—	144	—	67	4	69
4 weeks to 6th May	167	—	145	—	—	65	—	66	3	60

FIRE BRIGADE SERVICES.

	FIRE BRIGADE.					AMBULANCE.				
	1935-36	1936-37	1937-38	1938-39	1st Apr. to 30th Apr., 1939	1935-36	1936-37	1937-38	1938-39	1st Apr. to 30th Apr., 1939
CALLS—						CALLS—				
Hendon Area ..	184	171	216	265	18	Private Calls ..	781	945	1020	1304
Kingsbury Area ..	11	—	—	5	—	Street Calls ..	669	683	721	737
Other Areas ..	1	—	2	6	—	Total ..	1450	1628	1741	2041
False Alarms ..	61	36	47	57	2	Mileage run ..	13024	15467	15750	17361
Total ..	257	207	265	333	20	SPECIAL CALLS (Included in Total)				
Mileage run ..	1296	808	1055	1959	139	For Finchley ..	34	27	23	22
TRIPS—						For other Authorities	13	1	5	—
Alarms ..	4730	4502	5050	5604	533	Finchley for Hendon	—	4	1	4
Hydrants ..	1627	1978	2003	2293	112	Other Authorities for Hendon ..	—	1	5	2
INSPECTIONS—										
Petrol, Factory, etc.	826	702	747	554	—					
Private Appliances	233	179	197	49	—					

REFUSE DESTRUCTOR.

	1935-36		1936-37		1937-38		1938-39		1st April to 2nd May, 1939	
	T.	C.	T.	C.	T.	C.	T.	C.	T.	C.
OUTGOING MATERIALS—										
Fine Crushed Clinker	—	—	—	—	—	—	414	4	69	19
Coarse ditto	—	—	—	—	—	—	716	10	257	8
Fine Stuff sold	4863	5	5541	12	4806	9	2745	17	—	—
Fine Stuff used by Departments ..	5040	10	3393	—	5428	10	5867	1	640	10
Clinker Sold	1852	16	126	18	54	9	2270	19	211	16
Clinker used by Departments ..	218	7	729	16	68	7	912	19	49	18
Clinker supplied for Contract Works ..	2143	15	161	3	5106	13	2079	10	—	—
Tins (Bright) Sold	530	4	525	10	576	14	632	34	71	11
Tins (Galvanised) Sold	142	14	146	7	161	2	136	11	—	—
Bottles and Cullett Sold	401	15	473	10	914	1	499	1	51	6
Paper Sold	—	10	—	—	—	—	29	7	12	10
INCOMING REFUSE—										
House Refuse weighed in	30842	6	33678	3	34278	11	33408	6	3044	12
Trade Refuse	374	4	447	16	589	19	668	15	78	2
School Refuse	—	—	153	5	139	9	159	5	15	1
ELECTRICITY GENERATED—										
Workshop (Central Depot)	—	—	—	—	5438	—	4247	—	520	—
Refuse Destructor Works	—	—	28658	—	170380	—	193943	—	16800	—
Clinker Crushing Plant	—	—	—	—	—	—	3807	—	505	—
Totals	—	—	28658	—	175818	—	201997	—	17015	—

ADVANCES UNDER THE SMALL DWELLINGS ACQUISITION ACTS
from 3rd July, 1925, to 30th April, 1930.

	Advances completed		Council's Valuation		Amount Applied for		Amount Advanced		Advances now Outstanding		
	Number	Purchase Price	Amount	Percentage	Amount	Percentage	Amount	Percentage	Amount	Percentage	Number
Now Reported											
Details	307	279004	255224		205688		199633		46440		145
Percentages of Purchase Price				91%				71%		18%	
Valuation						80%		78%		25%	
Amt. Applied for								97%			
Advances											
Previous Return											
Details	307	279004	255224		205688		199633		47100		147
Percentages of Purchase Price				91%				71%		19%	
Valuation						80%		78%		24%	
Amt. Applied for								97%			
Advances											

HOUSING STATISTICS.

Year Ended 31st March	No. of Houses	COLLECTIBLE			TOTAL	COLLECTED			REPAIR NOTES		Elec- tricity Charges Collected	No. Empty at End
		Gross Rents	Nett Arrears Brought Forward			Rents Received	Void, Written Off, etc.	Nett Arrears Carried Forward	Issued during Month	Jobs Done		
1936	1150	46881 7 10	380 19 1	47262 6 11	46322 17 3	491 11 10	447 17 10	—	—	861 13 11	7	
1937	1150	45962 11 9	447 17 10	46410 9 7	45617 2 1	223 12 4	569 15 2	—	—	1133 3 1	2	
1938	1169	46046 6 1	569 15 2	46616 1 3	45945 15 1	119 15 2	550 11 0	—	—	1478 18 7	1	
1939 Week ended												
April 3	1290	1047 5 2	540 19 2	1588 4 4	1080 14 9	3 14 3	503 15 4	—	—	42 6 6	4	
10	1290	1047 5 2	503 15 4	1551 0 6	1013 17 4	3 11 2	513 12 0	—	—	43 15 9	4	
17	1290	1047 5 2	533 12 0	1580 17 2	1023 4 8	6 8 1	551 4 5	—	—	43 9 1	7	
24	1290	1047 7 9	551 4 5	1598 12 2	1071 1 11	4 8 1	523 2 2	175	230	45 4 6	5	
		4189 3 3	540 19 2	4730 2 5	4188 18 8	18 1 7	523 2 2	175	230	174 15 10	5	

1938-39
1324
737
2541
17301

1st April to
2nd Mar. 1939

T. C.
69 19
257
640 10
211 16
49 18
71 11
51 6
11 10

1044 12
78 2
15 1

B.T. Units
120
1680
505

17915

ADVANCES
OUTSTANDING

Per-
centage

18%
25%

19%
24%

LIBRARY SERVICES.—Statistics for April, 1939.

Table I. Members.

Distribution of Resident Members				Distribution of Non-Resident Members			
Ward	Population, June, 1938 (est)	Total Members	Percentage of Population	Library Authority	Employees, Scholars and those qualified under reciprocal agreements	Subscribers	
Central	19416	6551	33.74	Finchley	364	—	
Park	16671	5308	31.84	Middlesex	599	—	
Golders Green	15695	5425	34.56	Adjoining Library Authorities—			
Mill Hill	24899	8652	34.75	(a) Hampstead ...	35	1	
Childs Hill	18396	3863	20.99	(b) Willesden ...	35	—	
Burnt Oak	21200	5856	27.62	Metropolitan Boroughs ...	72	—	
West Hendon	19232	3063	15.92	(excluding Hampstead)			
Garden Suburb	15347	6033	39.29	Other Authorities ...	94	3	
Edgware	14487	2814	19.42				
Total	165343	47563	28.76	Total	1199	4	

Table II. General—Year 1939/40.

Type	Lectures						Inter Library Loans		Donations	
	Central		Golders Green		Mill Hill		Volumes		Details	Number
	Number	Attendance	Number	Attendance	Number	Attendance	Borrowed	Lent		
Now Reported										
University Extension	1	10	—	—	—	—	34	28	Volumes ...	33
Public Lectures	—	—	—	—	—	—			Pamphlets ...	30
Talks to Children	—	—	—	—	—	—			Maps ...	11
Story Half-Hours	—	—	—	—	—	—			Sets of Cigarette Cards	3
Total	1	10	—	—	—	—	34	28	Total ...	77
Previously Reported										
University Extension	—	—	—	—	—	—	—	—		
Public Lectures	—	—	—	—	—	—	—	—		
Talks to Children	—	—	—	—	—	—	—	—		
Story Half-Hours	—	—	—	—	—	—	—	—		
Total	—	—	—	—	—	—	—	—	Total ...	—

LIBRARY SERVICES.

Comparative Table of Issues.

Period	Central Library		Golders Green Branch		Mill Hill Branch		Deposit Stations	School Libraries	Total (All Services)
	Total Issues.	Daily Average	Total Issues	Daily Average	Total Issues	Daily Average			
March 1933 ...	43948	1920					380	13012	57340
March 1934 ...	42613	1639					477	18701	61791
March 1935 ...	41153	1583					373	21084	62010
March 1936 ...	39030	1501	35669	1372			287	15717	90703
March 1937 ...	40323	1613	35041	1401			277	15693	91334
March 1938 ...	37961	1400	34058	1261	32207	1193	—	23095	127311
March, 1939 ...	39446	1461	33581	1243	30426	1127	—	30884	134337
Period 1939/40									
April 1939 ...	37401	1626	33090	1439	29509	1283	—	7504	107504

Classified Table of Issues—April, 1939.

Classification	Central Library	Golders Green Branch	Mill Hill Branch	Total Central and Branches	School Libraries	Total (All Services)
General Works ...	662	273	410	1345	126	1471
Philosophy ...	368	281	187	836	24	860
Religion ...	368	221	185	774	81	855
Sociology ...	1954	1044	1008	4006	352	4358
Languages ...	547	171	191	909	31	940
Science ...	992	737	878	2607	291	2898
Useful Arts ...	2208	720	1454	4382	579	4961
Fine and Recreative Arts ...	1267	793	803	2863	322	3185
Music ...	706	400	341	1447	—	1447
Literature ...	2504	2255	1297	6056	225	6281
History and Topography	3208	1957	2021	7186	359	7545
Biography ...	1812	1518	1166	4496	84	4580
Local ...	311	—	—	311	—	311
Fiction ...	16730	18976	15489	51195	—	51195
Story Books	2646	3711	4079	10436	5030	15466
Books for the Blind...	23	—	—	23	—	23
Illustrations ...	235	—	—	235	—	235
Holiday Literature	860	33	—	893	—	893
TOTAL ...	37401	33090	29509	100000	7504	107504
Daily average issue...	1626	1439	1283	—	—	—
Days open ...	23	23	23	—	—	—

COMPARATIVE STATISTICS.

PUBLIC PARKS.

YEAR ENDED 31st March	TENNIS						BOWLS		PUTTING	MINIATURE GOLF	CONVENIENCE FEES (Nos.)
	Courts	Single Tickets	Double Tickets	Court Tickets	Book Tickets	Special Tickets	Rinks	Tickets Sold	Tickets Sold	Tickets Sold	
1933	30	3333	1701	3644	81	159	12	194	16840	—	3831
1934	30	1787	471	9425	233	115	12	326	17010	—	5074
1935	32	2633	698	8483	211	177	12	129	16191	5587	7976
1936	32	2511	631	8188	193	119	12	183	13919	4928	7494
1937	32	3154	930	9250	190	208	12	1108	13589	5360	7697
1938	32	4201	1112	11898	225	197	12	500	18058	5659	11209
1939	34	4186	1050	13245	242	155	12	343	16192	6545	11705

1st April, 1939, to 30th April, 1939.

Basing Hill ..	2	39	16	84	—	—	—	—	—	—	224
Childs Hill ..	2	33	9	48	2	—	6	—	—	—	—
Clitterhouse ..	4	13	8	38	—	—	—	—	—	—	93
Hendon ..	9	184	40	390	12	—	—	—	—	—	38
Mill Hill ..	3	78	32	114	2	7	6	2	—	8	91
Princes ..	2	68	25	102	2	—	—	—	—	—	52
Stone Grove ..	2	58	5	115	2	—	—	—	—	—	209
Sunny Hill ..	4	34	9	72	1	4	—	—	—	—	112
Watling ..	2	13	—	79	3	—	—	—	—	—	—
West Hendon ..	2	14	3	46	—	—	—	—	—	—	83
Montrose ..	2	2	4	18	—	—	—	—	—	—	106
Totals ..	34	536	151	1100	24	11	12	2	—	8	1008
Increase on last return	—	—	—	—	—	—	—	—	—	—	—

PUBLIC LAVATORIES.

YEAR ENDED 31st March	LADIES					GENTLEMEN					
	Convenience			Nos.		Towels		Convenience		Towels	
	W.C.'s	Free	Total	Nos.		Basins	Nos.	W.C.'s	Nos.	Basins	Nos.
1933	12	3	15	29812		4	171	11	33793	4	603
1934	10	4	23	37616		6	177	16	40270	6	786
1935	28	4	32	42268		10	304	21	53589	10	1192
1936	28	4	32	51133		10	551	21	68272	10	1870
1937	28	4	32	56804		10	1839	21	77244	10	2397
1938	28	4	32	64154		10	1919	21	78912	10	2762
1939	33	5	38	62700		12	1971	25	81947	12	2744

1st April, 1939, to 30th April, 1939.

"The Bell" ..	5	1	6	727	2	27	4	907	2	42
Childs Hill ..	4	1	5	1076	2	36	4	977	2	47
Cricklewood Lane ..	2	—	2	—	—	—	2	1146	—	—
Edgware ..	5	—	5	692	2	32	2	582	2	37
Mill Hill ..	4	—	4	1136	2	39	3	617	2	48
Orange Hill Road ..	5	1	6	483	2	35	3	627	2	50
West Hendon ..	3	1	4	604	—	10	3	759	—	—
Hendon Central ..	5	1	6	745	2	25	4	762	2	53
Totals ..	33	5	38	5463	12	204	25	6377	12	277
Increase on last return	5	1	6	—	2	—	4	—	2	—

PUBLIC SLIPPER BATHS.

YEAR ENDED 31st March	1st CLASS		2nd CLASS		Extra Towels	Soap	Unemploy- ed (Free Baths)
	No. of Baths	Tickets Sold	No. of Baths	Tickets Sold			
1933	8	3967	25	17980	962	6025	331
1934	8	3752	25	19113	844	7212	141
1935	8	3856	25	19251	875	7499	46
1936	8	3571	25	18230	921	7340	19
1937	8	3581	25	19385	1141	8074	61
1938	8	3536	25	21040	1206	8281	100
1939	8	3730	25	20500	1185	7516	69

1st April, 1939, to 30th April, 1939.

Child's Hill.							
Ladies ..	2	5	5	245	—	10	—
Gentlemen ..	2	65	6	289	17	115	—
Total ..	4	70	11	534	17	120	—
West Hendon.							
Ladies ..	2	12	6	290	23	131	—
Gentlemen ..	2	157	8	644	41	285	4
Total ..	4	169	14	934	64	416	4
Total of both	8	239	25	1468	81	536	4
Increase on last return	—	—	—	—	—	—	—

OPEN AIR SWIMMING POOL—MILL HILL.

(16)

Details.	1937		1938		1939	
	1st May—3rd October	Tickets Sold	30th April—27th Sept.	Tickets Sold	26th April to	Tickets Sold
SEASONS:—						
Adults.—						
Sundays & Bank Holidays	10476		6556			
Weekdays	30242		21368			
		40718		27924		
Children.—						
Sundays & Bank Holidays	4987		3441			
Weekdays	23589		18935			
		28576		22396		
Season Pass.—						
Sundays & Bank Holidays	1874		1594			
Weekdays	6814		6604			
		8688		8198		
SUB-TOTAL		77982		58518		
School Children.—						
Hendon	9661		6390			Opened 29th April, 1939
Other Authorities	—		878			
		9661		7268		
TOTAL BATHERS		87643		65786		
MISCELLANEOUS:—						
Parking.—						
Cars	3438		2347			
Motor Cycles	503		381			
Bicycles	9487		7260			
Season Tickets	1		2			
		13489		9990		
Deposits.—						
Costumes		4010		1835		
Season Tickets.—						
Resident	202		92			
Adults	—		160			
School Children	—		2			
Non-Resident	5		—			
		207		254		
Hire of Towels, Cap, Costume and Slips		9856		5829		
Weighing Machines		3557		2587		

OPEN AIR SWIMMING POOL—WEST HENDON.

Details.	1937		1938		1939	
	3rd July—3rd October	Tickets Sold	30th April—2nd Oct.	Tickets Sold	29th April to	Tickets Sold
SEASONS:—						
Adults.—						
Sundays & Bank Holidays	2568		—			
7 a.m. to 12.30 p.m.	—		2171			
1.30 p.m. to closing	—		1852			
Weekdays	9549		11906			
		12117		15929		
Children.—						
Sundays & Bank Holidays	1124		—			
7 a.m. to 12.30 p.m.	—		674			
1.30 p.m. to closing	—		1039			
Weekdays	6361		8547			
		7487		10260		Opened 29th April, 1939
Season Pass.—						
Sundays & Bank Holidays	506		836			
Weekdays	1932		2853			
		2438		3689		
SUB-TOTAL		22042		29878		
School Children.—						
Hendon	981		6825			
Other Authorities	—		—			
		981		6825		
TOTAL BATHERS		23023		36703		
MISCELLANEOUS:—						
Parking.—						
Cars	176		304			
Motor Cycles	82		119			
Bicycles	937		2237			
Season Tickets	—		—			
		1195		2660		
Deposits.—						
Costumes		1448		1036		
Season Tickets.—						
Resident	43		—			
Adults	—		35			
School Children	—		21			
Non-Resident	9		5			
		52		61		
Hire of Towels, Cap, Costume and Slips		3206		3651		
Weighing Machines		—		600		

WAGES RETURN.

Year Ended 31st Mar.	Net Wages Paid.	Deductions						*Contributions N.H. & U. Insurances	TOTAL.
		Compulsory		Voluntary					
		Super- annuation	N.H. & U. Insurances	Sports Club Subscrip- tions	Socials	Industrial Orthopaedic Society	Rent, Rates, etc.		
1932	81898 7 0	1416 7 3	1557 11 9	—	—	—	—	1688 5 1	87976 18 4
1933	82166 4 3	1368 7 2	1711 2 11	—	—	—	—	1805 7 10	88419 9 4
1934	95367 11 9	2149 0 2	1971 13 10	—	—	—	—	2077 11 2	103514 17 1
1935	102007 4 7	2107 11 7	2101 18 11	—	—	50 8 0	—	2215 12 6	110591 7 2
1936 (53 weeks)	107592 19 3	2581 11 11	2227 13 2	—	—	58 19 11	—	2360 4 4	117403 0 6
1937	106580 12 3	2465 6 2	2072 2 11	—	—	56 17 4	—	2210 3 5	115850 8 3
1938	116027 19 0	2405 4 10	2204 5 11	—	—	57 0 2	—	2383 10 5	125483 4 4
1939	£128550 1 2	2456 0 3	2335 19 2	134 8 0	561 2 6	56 10 2	—	2529 14 3	139079 15 9
* NOTE.—The contribution in respect of superannuation is equivalent to the deduction.									
1939 Week Ended									
April 4	2399 9 4	49 5 10	43 4 1	3 2 8	15 3 4	1 2 2	—	46 17 10	2607 11 1
11	2450 5 3	49 17 0	44 8 4	3 5 4	15 10 2	1 2 3	—	48 5 11	2671 11 3
18	2492 13 10	49 16 9	45 10 10	3 3 6	15 12 6	1 2 4	30 3 3	48 14 4	2736 14 1
25	2513 0 0	49 17 2	46 12 4	3 4 8	15 9 4	1 2 4	41 6 7	50 8 4	2774 6 11
May 2	2566 8 5	49 9 4	47 3 0	3 7 4	15 6 8	1 2 1	45 4 9	51 6 3	2838 17 2
9	2585 6 4	49 4 2	46 16 11	3 5 10	15 13 8	1 2 2	44 16 7	50 16 10	2846 6 8
Totals	£15016 12 2	*297 10 3	273 15 6	19 9 4	92 15 8	6 13 4	164 11 2	296 9 6	16465 7 2

* The contribution has the effect of doubling this sum.

LOAN DEBT STATEMENT

Particulars.	Balance Outstanding 1st April.	New Loans	Repayments	Balance Outstanding 31st March.
Year to 31st March, 1932	£2,012,708 3 8	£205,025 10 9	£85,745 3 8	£2,131,988 10 9
Year to 31st March, 1933	£2,131,988 10 9	£150,932 19 6	£135,395 12 10	£2,147,525 17 5
Year to 31st March, 1934	£2,147,525 17 5	£805,020 17 2	£615,939 18 2	£2,336,606 16 5
Year to 31st March, 1935	£2,336,606 16 5	£70,120 0 0	£67,764 2 9	£2,338,962 13 8
Year to 31st March, 1936	£2,338,962 13 8	£75,500 0 0	£182,049 18 2	£2,232,412 15 6
Year to 31st March, 1937	£2,232,412 15 6	£241,250 0 0	£66,785 18 9	£2,410,876 16 9
Year to 31st March, 1938	£2,406,876 16 9	£247,052 12 8	£310,238 4 0	£2,443,691 5 5
Year to 31st March, 1939	£2,343,691 5 5	£506,957 1 10	£447,062 6 11	£2,403,586 0 4

Purpose.	Balance Outstanding 1st April, 1939	New Loans and Advances to Borrowing Accounts to 30th Apr., 1939	Repayments and Advances from Loans Pool to 30th Apr., 1939	Balance Outstanding at 30th Apr., 1939
Sewerage and Sewage Disposal	280403 12 2	—	—	280403 12 2
Road Improvements:—				
Main and County Roads	84647 2 0	—	—	84647 2 0
Local Roads	84210 7 2	—	—	84210 7 2
Private Streets	53133 4 10	—	—	53133 4 10
Public Lighting	2500 0 0	—	—	2500 0 0
Parks and Pleasure Grounds	449888 1 6	—	—	449888 1 6
Public Offices and Buildings	63367 14 6	—	—	63367 14 6
Public Depots	16617 10 0	—	—	16617 10 0
Fire Station, etc.	22959 17 8	—	—	22959 17 8
Health Services:—				
House Refuse Collection	23753 2 8	—	—	23753 2 8
Hospitals	57258 11 6	—	—	57258 11 6
Maternity and Child Welfare	17018 19 1	—	—	17018 19 1
Public Conveniences	8357 7 1	—	—	8357 7 1
Mortuary	145 0 9	—	—	145 0 9
Baths and Washhouses	40917 7 4	—	—	40917 7 4
Public Libraries	40230 6 5	—	—	40230 6 5
Allotments	1245408 4 8	—	—	1245408 4 8
Small Dwellings Acts, Advances	13502 4 10	—	—	13502 4 10
Housing (1923 Act), Subsidies	47151 13 0	—	—	47151 13 0
Housing (1923 Act), Subsidies	140 2 8	—	—	140 2 8
Housing	675790 0 4	—	—	675790 0 4
Education:—				
Elementary	343539 11 10	—	—	343539 11 10
Higher	7689 1 0	—	—	7689 1 0
Loans Pool	2333220 18 4	10000 0 0	100 0 0	2333220 18 4
	70365 2 0			80265 2 0
Total	£2,403,586 0 4	£10,000 0 0	£100 0 0	£2,413,486 0 4

(19)

LOAN SANCTIONS RECEIVED—From 1st April, 1939, to 3rd May, 1939:

No.	Date of Sanction.	Purpose.	Amount.	Period. Years.
506	3rd May, 1939	Cricklewood Lane Improvement	£ 6578	20

PAYMENTS TO CONTRACTORS UNDER ENGINEER'S CERTIFICATES:

From 1st April, 1939, to 15th May, 1939.

Contract Works No.	Amount of Contract.	Amounts Certified by Engineer.				Total Certified.	Amount of Retention.
		Previously Reported.	Now Reported.		Total Certified.		
			Numbers.	Amount.			
	£ s. d.	£ s. d.		£ s. d.	£ s. d.	£ s. d.	
301	31446 15 2	20360 0 0	—	— — —	20360 0 0	5434 0 0	
340	9755 0 0	9000 0 0	11	164 7 2	9164 7 2	— — —	
355	18288 0 0	15325 0 0	—	— — —	15325 0 0	1828 0 0	
365	7573 5 0	6549 0 0	—	— — —	6549 0 0	727 9 2	
368	1600 0 0	1182 0 0	—	— — —	1182 0 0	62 7 6	
369	2675 0 0	2033 0 0	—	— — —	2033 0 0	267 0 0	
371	20473 0 0	15779 0 0	10	1474 0 0	17253 0 0	2047 0 0	
371	1448 0 0	1297 6 6	—	— — —	1297 6 6	144 3 0	
378b	9611 13 7	3519 0 0	5	1681 0 0	5200 0 0	1300 0 0	
381	4194 7 2	1678 0 0	6	186 15 9	1864 15 9	— — —	
386	853 0 0	713 6 0	—	— — —	713 6 0	79 5 0	
386	5163 0 0	3995 0 0	—	— — —	3995 0 0	999 0 0	
389	1375 6 7	831 0 0	3	92 2 3	923 2 3	— — —	
394	552 12 10	377 0 0	4	42 4 1	419 4 1	— — —	
397	23577 18 3	16758 0 0	8	1484 0 0	18242 0 0	2358 0 0	
398	790 0 0	711 0 0	2	79 0 0	790 0 0	— — —	
399	34179 4 6	5120 0 0	3 & 4	11680 0 0	16800 0 0	4200 0 0	
401	1369 9 9	339 0 0	2	195 0 0	534 0 0	59 4 1	
401	1415 17 10	373 0 0	2	209 0 0	582 0 0	64 5 1	
401	3006 7 3	674 0 0	2	676 0 0	1350 0 0	149 1 0	
401	867 0 2	216 0 0	2	117 0 0	333 0 0	36 16 9	
401	Kerb	1008 0 0	—	— — —	1008 0 0	112 0 0	
401	Surfacing	— — —	1	1887 6 2	1887 6 2	— — —	
401	Surfacing	— — —	1	218 3 1	218 3 1	— — —	
405	414 0 0	328 6 10	—	— — —	328 6 10	36 0 0	
A.R.P. Trenches	— — —	2934 11 8	—	— — —	2934 11 8	— — —	
A.R.P. Shelters	— — —	640 5 10	—	9 2 11	649 8 9	— — —	
A.R.P. Timber	— — —	5393 1 6	—	14 1 10	5407 3 4	— — —	
Brent Street Paving	1200 0 0	830 0 0	2	93 1 0	923 1 0	— — —	

QUOTATIONS ACCEPTED, CONTRACTS LET, ETC.:

Date of Minute.	Minute Folio.	Particulars.	Amount of Contract.
1939.		Estates, Parks and Allotments:—	£ s. d.
8th May	609	Lease for Grazing—Arrandeno	2 0 0
8th May	610	Sale of Refreshments—Permit:— J. T. Enright—Woodfield Park	2 10 0
		The Park Supplies—Sunny Hill	5 0 0
8th May	610	Camp Permit—War Office	1 0 0
8th May	610	Latrines—Moat Mount Camp	850 0 0
8th May	673	Tractor—Spurling Motors Ltd.	615 2 0
8th May	673	Fencing in 8 Parks—Prove Bros. Ltd.	158 12 11
		Highways:—	
8th May	611	Surfacing Carriageways:—Devonshire Road and Crescent, Aberdare Gardens and Osborne Gardens—G. Wimpey & Co. Ltd.—per square yard	3 10
		Surfacing Margins:—Devonshire Road and Crescent, Aberdare Gardens and Osborne Gardens—G. Wimpey & Co. Ltd.—per square yard	3 3
8th May	670	Supply of Tarmacadam and Tarpaving—Constable Hart & Co. Ltd.—per ton	£1 2 11 to £1 5 3
8th May	667	Making up Southsover—C. Carter	684 11 1
		Works and Fire Brigade:—	
8th May	611	Repairs to Ambulance, BML 945—Sunbeam Talbot Ltd.	82 2 0
		Public Health:—	
8th May	660	Subscription—Health and Cleanliness Council	1 1 0
		Air Raid Precautions:—	
8th May	640	Clothing for Auxiliary Fire Service	1172 1 0
8th May	640	Hire of Vehicles for Test Mobilisation	5 5 0
8th May	707	Six One-ton Vans—each	15 0 0
8th May	707	Three Stretcher Racks	5 10 0
8th May	707	Lease of Archway for Sandbag Store—London Passenger Transport Board—per annum exclusive	30 0 0
8th May	708	Equipment for Medical Services	48 0 0
		Education:—	
8th May	611	Fuel—J. Hudson & Co. Ltd.:— Pens—per ton	1 12 6
		Singles—per ton	1 13 6
8th May	647	Fire Extinguishers—Dole Street School—Nuswift Engineering Co. Ltd.	23 8 0
8th May	648	Repairs Electric Circuits—Meads School	85 0 0

D
E
F
G
H
I
J
K
L
M
N
O
P
Q
R
S
T
U
V
W
X
Y



Borough of Hendon.

NOTICE IS HEREBY GIVEN

That an Ordinary Meeting of the Council of the Borough of Hendon, in the County of Middlesex, will be held on **Monday** next, the **17th** day of **July, 1939**, at **6** o'clock in the afternoon, at the Town Hall, The Burroughs, Hendon, N.W. 4, and all and several the Members of the said Council are hereby summoned to attend.

The business to be transacted at such meeting is as follows:—

1. To confirm Minutes of the Statutory Meeting of the Borough Council held on the 19th June, 1939.
2. Official Announcements.
3. Questions.
4. To approve, or otherwise, the Reports of the following Committees, viz.:—
Education; Public Health and Medical Services; Highways; Estates, Parks and Allotments; Works and Fire Brigade; Libraries and Local Pensions; Housing; Buildings and Town Planning; Rating and Valuation; Air Raid Precautions; and Finance and General Purposes.
5. To authorise the sealing of the following documents:—

Deed of Apprenticeship	Mr. S. Goodrich and D. J. Goodrich, Junior, and the Corporation— for training and instruction in gardening.
Deed of Apprenticeship	Mr. J. Lovatt and D. Lovatt, Junior, and the Corporation— for training and instruction in gardening.
Counterpart Agreement	London Passenger Transport Board and the Corporation— as to tenancy of Underground Railway Arch at Burnt Oak.
6. Reports (if any) of Officers.
7. Summer Recess.

To RESOLVE—That His Worship the Mayor, or in his absence the Deputy Mayor, be vested with power to deal with all urgent matters which may arise during the Summer Recess, *i.e.*, 18th July to the 18th September.

Town Clerk's Office,
Hendon, N.W. 4.
12th July, 1939.

Town Clerk.

INDEX.

— o —

MINUTES Page 886 to 893

REPORTS:—

EDUCATION COMMITTEE 894 to 910
PUBLIC HEALTH & MEDICAL SERVICES COMMITTEE 911 to 919
HIGHWAYS COMMITTEE 920 to 926
ESTATES, PARKS & ALLOTMENTS COMMITTEE 927 to 932
WORKS & FIRE BRIGADE COMMITTEE 933 to 940
LIBRARIES & LOCAL PENSIONS COMMITTEE 941 to 845
HOUSING COMMITTEE 946 to 949
BUILDINGS & TOWN PLANNING COMMITTEE 950 to 961
RATING & VALUATION COMMITTEE 962
AIR RAID PRECAUTIONS COMMITTEE 963 to 971
FINANCE & GENERAL PURPOSES COMMITTEE 972 to 982

Minutes.

At a Statutory Meeting of the COUNCIL of the BOROUGH OF HENDON, held at the Town Hall, The Burroughs, Hendon, N.W. 4, on Monday, the 19th day of June, 1939, at 6 o'clock p.m.

PRESENT:

His Worship the Mayor (Councillor H. C. Potter, J.P., F.S.I.), in the Chair.

Aldermen:

W. R. Clemens, F.C.A.,

J. J. Copestake, J.P.,

R. A. B. Teare, M.B.E.

Councillors:

E. Arter, M.C., M.I.A.E.,

C. H. Hignett,

T. Pugh,

T. K. Bridge,

L. Hirshfield,

C. R. Richardson,

F. H. Bate,

P. Lightfoot,

J. H. Rodway,

F. J. Collins,

A. A. Naar, M.B.E.,

T. J. Scott,

E. J. Cox,

(Mrs.) F. E. Parvin,

W. H. N. Shakespeare,

A. W. Curton,

C. Pinkney,

M.C., A.F.C., J.P.,

F. W. Gilpin,

G. J. Pryke, F.I.A.C.,

H. P. Small,

A. W. Greville,

A.M.I.S.E.,

C. F. Windust.

J. Griffiths,

NOTICE OF MEETING:

The Town Clerk read the notice convening the Meeting.

MINUTES—CONFIRMATION:

Moved by Alderman Copestake, seconded by Alderman Teare, and

285.—RESOLVED—**That the Minutes of the Special Meeting of the Borough Council held on the 12th June, 1939, be confirmed.**

APOLOGIES FOR ABSENCE:

Apologies for absence were submitted on behalf of Aldermen S. H. Egan, J.P. (Deputy Mayor), B. Flowers, W. M. Maughan, J.P., B. J. Monroe, F. C. Rice; Councillors H. Connell, J.P., and Mrs. M. Thomas.

OFFICIAL ANNOUNCEMENTS:

His Worship the Mayor announced that Alderman Egan anticipated returning to his Council duties on 26th June, and that Councillor (Mrs.) Thomas hoped to resume her Council work in the near future. The Mayor further reported that there was an improvement in the condition of Alderman Brook Flowers, but that his progress was very slow.

Hendon Cottage Hospital Fête.

His Worship the Mayor intimated that, with the Mayoress, he would be opening the Hendon Cottage Hospital Fête at 2.30 p.m. on Saturday the 1st July and would welcome the company of Members of the Council and their ladies, for whom seating accommodation would be provided on the platform on notice of their intention to be present being given to the Secretary of the Hospital.

Golders Green Bowling Club.

The Mayor reported that he had accepted an invitation to visit the Golders Green Bowling Club on the 6th July and that Members desirous of joining in the games on this occasion should notify Alderman Copestake at an early date.

St. Judes, Garden Suburb.

His Worship reported that he proposed officially to attend Morning Service at St. Judes on Sunday the 16th July at 11.30 o'clock and intimated that he would be glad of the support of his colleagues. The usual arrangements would be made for Members and their ladies, and those intending to be present were asked to notify his Secretary in due course.

QUESTION:

Guard Rails, Golders Green.

Pursuant to notice duly given in accordance with Standing Order No. 22, Alderman Copestake, asked the Chairman of the Highways Committee the following questions:—

1. *Are the Guard Rails placed at Golders Green of an experimental nature?*
2. *Is he aware of the strong feeling existing amongst the local tradesmen and pedestrians as to the erection of these rails?*
3. *Has he received a request for a deputation to be received representing the local shopkeepers and, if so, has he given his consent to hear their case at the next meeting of the Highways Committee?*
4. *Are there any more Guard Rails to be fixed at Golders Green and, if so, will he give instructions for the holding up of further erection until after the Deputation has been heard, if it has been agreed to receive such Deputation?*
5. *Has the Chairman of the Highways Committee inspected these Guard Rails already erected?*

Reply by Chairman of the Highways Committee (Councillor Curton):—

1. The Guard Rails are not of an experimental nature. They are on similar lines to the Guard Rails which have been placed with success at many important traffic centres in London, including Hendon Central.
2. So far as pedestrians are concerned no complaints have been received and up to the present time observations show that the Guard Rails are doing some good so far as pedestrians are concerned. A number of objections have been received from tradesmen.
3. A request for a deputation has been received and I have agreed to such deputation appearing before the Highways Committee at their next meeting.
4. The erection of the Guard Rails is now practically completed. 1,076 feet of Guard Rails have been erected up to date and a further 275 feet remain to be erected. The Council are committed to the scheme which was recommended by the Minister of Transport. Of the 275 feet of Guard Rail yet to be fixed, 90 feet are to be erected in the Finchley Road north of the cross roads and 185 feet in the Finchley Road south of the cross roads.
5. I have inspected the Guard Rails on various occasions during the course of erection. The Guard Rails are being erected in conjunction with the system of traffic signalling which is to be installed at the cross roads.

REPORTS OF COMMITTEES.**EDUCATION COMMITTEE:****REPORT NO. 1.**

Moved by Alderman Copestake, seconded by Councillor Scott, and

286.—RESOLVED—That Report No. 1 of the Education Committee (Meeting held on 23rd May, 1939—Agenda, pages 778-797) be received.

Page 796—Burnt Oak School—Stripping and Retiling Roof.

AMENDMENT moved by Alderman Clemens, duly seconded:—

THAT the following words be added after the word "accepted":—

"subject to the usual financial enquiries."

On submission, the amendment was declared **carried**.

- 287.—Accordingly **RESOLVED**—That the lowest tender, namely, that of Messrs. **Roberts and Burling Ltd.**, amounting to £399 13s. 3d. be accepted subject to the usual financial enquiries for carrying out the work, and that the Corporate Seal be affixed to the Contract.

ADOPTION OF REPORT: Moved by Alderman Copestake, seconded by Councillor Scott, and

- 288.—**RESOLVED**—That Report No. 1 of the Committee in so far as it relates to matters requiring the confirmation of the Council be approved and adopted, as amended.

REPORT NO. 2.

Moved by Alderman Copestake, seconded by Councillor Scott, and

- 289.—**RESOLVED**—That Report No. 2 of the Education Committee (Meeting held on the 23rd May, 1939—Agenda, page 798) be received.

ADOPTION OF REPORT: Moved by Alderman Copestake, duly seconded, and

- 290.—**RESOLVED**—That Report No. 2 of the Education Committee in so far as it relates to matters requiring the confirmation of the Council be approved and adopted.

PUBLIC HEALTH AND MEDICAL SERVICES COMMITTEE:

Moved by Councillor Scott, seconded by Councillor Hirschfield, and

- 291.—**RESOLVED**—That the report of the Public Health and Medical Services Committee (Meeting held on the 15th May, 1939—Agenda, pages 799-804) be received.

Resignation of Dr. S. L. Wright.

The Chairman of the Committee (Councillor Scott) reported that since the Meeting of the Committee, Dr. S. L. Wright had tendered his resignation to take effect on the 11th July, 1939, upon his appointment as Deputy Medical Officer of Health to the Borough of Wembley.

Motion moved by Councillor Scott, seconded by Councillor Curton, and

- 292.—**RESOLVED**—That Dr. S. L. Wright be heartily thanked for his services with the Council and authority given for the issue of an advertisement for the appointment of an Assistant Medical Officer of Health at a salary of £600 per annum, rising by annual increments of £25 to £750 per annum with a car allowance of £50 per annum.

Page 802—Item 14—Shops Acts, 1934.

In reply to Councillor Pugh, who asked the Chairman of the Committee whether the Council had sufficient staff to ensure adequate inspection and the carrying out of observations under the Shops Acts, having regard to the large number of business premises which have been opened since the matter was last under consideration, or whether an additional appointment was necessary, the Chairman of the Committee stated that he would bring the matter before the next meeting of the Committee, or the next following meeting.

ADOPTION OF REPORT: Moved by Councillor Scott, seconded by Councillor Hirshfield, and

293.—RESOLVED—That the report of the Public Health and Medical Services Committee, as amended, be approved and adopted.

HIGHWAYS COMMITTEE:

Moved by Councillor Curton, seconded by Councillor Arter, and

294.—RESOLVED—That the report of the Highways Committee (Meeting held on the 15th May, 1939—Agenda, pages 805-808) be received.

Page 805—Item 2—Street Trading, Watling Avenue.

In reply to Councillor Pugh, who drew attention to the obstruction caused by street trading on the public footpath in Watling Avenue, the Chairman of the Committee stated that the matter would receive attention.

ADOPTION OF REPORT: Moved by Councillor Curton, seconded by Councillor Windust, and

295.—RESOLVED—That the report of the Highways Committee be approved and adopted.

ESTATES, PARKS AND ALLOTMENTS COMMITTEE:

Moved by Councillor Collins, seconded by Alderman Teare, and

296.—RESOLVED—That the report of the Estates, Parks and Allotments Committee (Meeting held on the 15th May, 1939—Agenda, pages 809-813) be received.

Page 809—Item 2—Community Centre—Clitterhouse Area.

AMENDMENT moved by Alderman Clemens, seconded by Councillor Naar:—

THAT the following be inserted after the word "rental":—

"of £10 per annum,"

and that Recommendation 2 be deleted.

On submission, the amendment was declared **carried**, 13 voting for and 8 against.

FURTHER AMENDMENT moved by Councillor Shakespeare, seconded by Councillor Hignett:—

THAT Item 2 of the Committee's Report and their recommendation thereon be referred back.

Councillor Hignett gave notice of a further amendment.

After discussion the further amendment was submitted and declared **lost**.

An amendment moved by Councillor Hignett to the effect that a rental of £20 per annum be charged, was not seconded.

SUBSTANTIVE MOTION: Upon submission of the motion, as amended, as the substantive motion it was declared **carried**.

297.—Accordingly RESOLVED—That the Education Committee be authorised to inform the County Education Authority, that, subject to the consent of the Minister of Health and to the removal of the restrictive covenants, the Hendon Town Council are prepared to grant a lease of 21 years on approximately one-half acre of land at a nominal rental of £10 per annum, on the Clitterhouse Open Space for the erection of a Community Centre.

Page 810—Item 3—Mill Field—Mill Hill Social Service Committee.

AMENDMENT moved by Alderman Clemens, seconded by Councillor Curton:—
 THAT the following be inserted after the word "user":—

"Such indemnity to be covered by insurance if necessary."

On submission, the amendment was declared **carried**.

298.—Accordingly **RESOLVED**—That the application for the use of the lower end of the Mill Field be approved, subject to the Council being fully indemnified against all costs and claims arising out of the user, such indemnity to be covered by insurance if necessary, and an undertaking being given to make good any damage to the property.

ADOPTION OF REPORT: Moved by Councillor Collins, seconded by Alderman Teare, and

299.—**RESOLVED**—That the report of the Estates, Parks and Allotments Committee, as amended, be approved and adopted.

WORKS AND FIRE BRIGADE COMMITTEE:

Moved by Councillor Naar, seconded by Councillor (Mrs.) Parvin, and

300.—**RESOLVED**—That the report of the Works and Fire Brigade Committee (Meeting held on the 22nd May, 1939—Agenda, pages 814-820) be received.

Page 815—Item 6—London Professional Fire Officers' Board.

AMENDMENT moved by Councillor Curton, seconded by Councillor Bridge:—

THAT the above matter be referred back for further consideration.

After discussion the amendment was submitted and declared **lost**.

Page 817—Item 8—Mr. R. E. Stimpson.

AMENDMENT moved by Councillor Richardson, seconded by Councillor Rodway:—

THAT the second paragraph of the Committee's Report on the above matter be deleted and the following words substituted:—

"Resolved—That Mr. Stimpson be invited to appear before the next meeting of the Council."

After discussion the amendment was submitted and declared **lost**, whereupon a division was demanded by Councillor Richardson and two other Members and taken with the following result:—

For 10.	Against 14.	Abstained from Voting 2.	Absent when Division taken 10.
Alderman Teare.	Alderman Clemens.	The Mayor.	The Deputy Mayor.
Councillor Cox.	Copestake.	Councillor Bridge.	Alderman Flowers.
Griffiths.	Councillor Arter.		Maughan.
Hirshfield.	Bate.		Monro.
Pinkney.	Collins.		Reynolds.
Pugh.	Curton.		Rice.
Richardson.	Gilpin.		Councillor Connell.
Rodway.	Greville.		Hicks.
Small.	Hignett.		Shakespeare.
Windust.	Lightfoot.		(Mrs.) Thomas.
	Naar.		
	(Mrs.) Parvin.		
	Pryke.		
	Scott.		

Page 818—Item 19—Training and Social Hut—Fenella.

AMENDMENT moved by Alderman Clemens, seconded by Alderman Copestake:—

THAT the following words be inserted after the word "tender":—

"that of Mr. H. Pickrill."

On submission, the amendment was declared **carried**.

301.—Accordingly **RESOLVED**—

- (1) **That subject to the approval of the Home Office and to the usual financial enquiries the lowest tender, that of Mr. H. Pickrill, amounting to £505 be accepted.**
- (2) **That the Corporate Seal be affixed to any necessary documents.**

Page 819—Item 22—Redhill Hospital and Institution.

AMENDMENT moved by Alderman Clemens, seconded by Alderman Copestake:—

THAT the following words be inserted after the word "rental":—

"of £15."

On submission, the amendment was declared **carried**.

302.—Accordingly **RESOLVED**—**That Camewell Fire Alarms be installed in the Redhill Hospital and the Institution, subject to an annual rental of £15 for the installation to cover all costs to the Town Council being paid by the Middlesex County Council.**

ADOPTION OF REPORT: Moved by Councillor Naar, seconded by Councillor Windust, and

303.—**RESOLVED**—**That the report of the Works and Fire Brigade Committee, as amended, be approved and adopted.**

LIBRARIES AND LOCAL PENSIONS COMMITTEE:

Moved by Councillor Lightfoot, seconded by Councillor Scott, and

304.—**RESOLVED**—**That the report of the Libraries and Local Pensions Committee (Meeting held on the 22nd May, 1939—Agenda, pages 821-822) be received.**

Page 822—Item 5—Staff—Military Service.

AMENDMENT moved by Alderman Clemens, seconded by Alderman Copestake:—

THAT the above recommendation be deleted and the following substituted:—

"That the attention of the Libraries Committee be drawn to Item No. 12 of the Finance and General Purposes Committee Report (12/6/39) as to the engagement of temporary employees necessitated by the calling up of members of the permanent staff for Military Service."

On submission, the amendment was declared **carried**.

305.—Accordingly **RESOLVED**—**That the attention of the Libraries Committee be drawn to Item 12 of the Finance and General Purposes Committee Report (12/6/39) as to the engagement of temporary employees necessitated by the calling up of members of the permanent staff for Military Service.**

ADOPTION OF REPORT: Moved by Councillor Lightfoot, seconded by Councillor Scott, and

- 306.—RESOLVED—That the report of the Libraries and Local Pensions Committee, as amended, be approved and adopted.

HOUSING COMMITTEE:

Moved by Councillor Gilpin, seconded by Alderman Teare, and

- 307.—RESOLVED—That the report of the Housing Committee (Meeting held on the 22nd May, 1939—Agenda, pages 823-825) be received.

ADOPTION OF REPORT: Moved by Councillor Gilpin, seconded by Alderman Teare, and

- 308.—RESOLVED—That the report of the Housing Committee be approved and adopted.

BUILDINGS AND TOWN PLANNING COMMITTEE:

Moved by Councillor Hignett, duly seconded, and

- 309.—RESOLVED—That the report of the Buildings and Town Planning Committee (Meeting held on the 22nd May, 1939—Agenda, pages 826-838) as amended by the deletion of the asterisk preceding the name of Councillor Arter in the list of members of the Committee, be received.

ADOPTION OF REPORT: Moved by Councillor Hignett, seconded by Councillor Arter, and

- 310.—RESOLVED—That the report of the Buildings and Town Planning Committee, as amended, be approved and adopted.

RATING AND VALUATION COMMITTEE:

Moved by Councillor Small, seconded by Councillor Curton, and

- 311.—RESOLVED—That the report of the Rating and Valuation Committee (Meeting held on the 13th June, 1939—Agenda, page 839) be received.

AIR RAID PRECAUTIONS COMMITTEE:

REPORT NO. 1.

Moved by Councillor Arter, seconded by Councillor Curton, and

- 312.—RESOLVED—That Report No. 1 of the Air Raid Precautions Committee (Meeting held on the 16th May, 1939—Agenda, pages 840-851) be received.

ADOPTION OF REPORT: Moved by Councillor Arter, seconded by Councillor Curton, and

- 313.—RESOLVED—That Report No. 1 of the Air Raid Precautions Committee be approved and adopted.

REPORT NO. 2.

Moved by Councillor Arter, seconded by Councillor Curton, and

- 314.—RESOLVED—That Report No. 2 of the Air Raid Precautions Committee (Meeting held on the 30th May, 1939—Agenda, pages 852-858) as amended by the denoting of the Attendance of Councillor Naar at the Meeting of the Committee, be received.

ADOPTION OF REPORT: Moved by Councillor Arter, seconded by Alderman Teare, and

- 315.—RESOLVED—That Report No. 2 of the Air Raid Precautions Committee, as amended, be approved and adopted.

REPORT NO. 3.

Moved by Councillor Arter, seconded by Councillor Curton, and

- 316.—RESOLVED—That Report No. 3 of the Air Raid Precautions Committee (Meeting held on the 13th June, 1939—Agenda, pages 859-869) be received.

ADOPTION OF REPORT: Moved by Councillor Arter, seconded by Alderman Copestake, and

- 317.—RESOLVED—That Report No. 3 of the Air Raid Precautions Committee be approved and adopted.

FINANCE AND GENERAL PURPOSES COMMITTEE:

Moved by Alderman Clemens, seconded by Alderman Copestake, and

- 318.—RESOLVED—That the report of the Finance and General Purposes Committee (Meeting held on the 12th June, 1939—Agenda, pages 870-885) be received.

ADOPTION OF REPORT: Moved by Alderman Clemens, seconded by Alderman Copestake, and

- 319.—RESOLVED—That the report of the Finance and General Purposes Committee be approved and adopted.

SEALING OF DOCUMENTS:

Moved by Councillor Naar, seconded by Alderman Teare, and

- 320.—RESOLVED—That the Corporate Seal be affixed to the following documents:—

Agreement and Transfer	J. B. Hider, Esq. and Another, and the Corporation— <i>re</i> dedication of land abutting on Hendon Wood Lane.
Deed of Apprenticeship	Mr. F. E. Wicks and R. J. Wicks, Junior, and the Corporation—for training and instruction in gardening.
Conveyance	The Trustees of the Will of J. C. Williamson, deceased, to the Corporation— <i>re</i> land at junction of Dollis Road and Thornfield Avenue, Hendon.
Agreement and Transfer	T. W. Heath (Neasden) Limited and the Corporation— <i>re</i> transfer of land at Crossway.

BUILDING BYELAWS—SEALING:

The Town Clerk reported that on the 8th May, 1939 (B. & T.P.C., 24/4/39-12) the Council gave authority for the terms of the above Byelaws to be agreed with the Ministry of Health, and upon settlement for the necessary notice to be issued under the Local Government Act, 1933, and the Public Health Act, 1936. The draft in an agreed form was returned by the Minister on the 25th May and notice of intention to apply for confirmation of the Byelaws was issued on the 16th June.

- 321.—RESOLVED—That the Corporate Seal be affixed to the Byelaws set out in the Appendix hereto.

The Meeting terminated at 7.52 p.m.

Herbert Pate
Mayor.

Committee (Meet-
received.

seconded by

Committee be

d

Committee
be received.

seconded by

Committee

Documents:—

the Corpor-
abutting on

Junior, and
and instrue-

Williamson,
re land at
Thornfield

and the
and at Cross-

4/4/39—12)
agreed with
to be issued
The draft
ice of inten-
ne.

t out in the

APPENDIX.



Borough of Mendon.

BYELAWS

WITH RESPECT TO

BUILDINGS

D
E
F
G
H
J
K
L
M
N
O
P
Q
R
S
T
U
V

BUILDING BYELAWS



*made under the Public Health Act, 1936, by the Mayor,
Aldermen and Burgesses of the Borough of Hendon, acting by
the Council for the Borough of Hendon.*

PART I—INTRODUCTORY.

INTERPRETATION OF TERMS.

1. In these byelaws, unless the context otherwise requires,—

“base”, applied to a wall, means the under side of that part of the wall which immediately rests upon the footings or foundation or upon any bressummer or other structure by which such wall is carried;

“bressummer” means a beam or girder which carries a wall;

“building of the warehouse class” means a warehouse or factory;

“council” means the Mayor, Aldermen and Burgesses of the Borough of Hendon, acting by the Council;

“dead load” means the weight of all walls, floors, roofs, partitions and other like permanent construction;

“district” means the Borough of Hendon;

“domestic building” means a dwelling-house, shop, office building or any other building which is neither a public building nor a building of the warehouse class;

“ external wall ” means an outer wall of a building not being a party wall, even though adjoining a wall of another building;

“ height ”, applied to a building, means the height of the building measured from the mean level of the ground adjoining the outside of the external walls to the level of *half* the vertical height of the roof, or to the top of the walls or of the parapet, if any, whichever is the higher;

“ mortar ” means cement mortar, cement-lime mortar, lime mortar or black mortar;

“ party wall ” means—

(1) a wall forming part of a building and used or constructed to be used for separation of adjoining buildings belonging to different owners, or occupied or constructed or adapted to be occupied by different persons; or

(2) a wall forming part of a building and standing, to a greater extent than the projection of the footings, on lands of different owners;

“ public building ” means a building used or constructed or adapted to be used, either ordinarily or occasionally, as a church, chapel or other place of public worship, or as a hospital, public institution, college or school (not being merely a dwelling-house so used), theatre, public hall, public concert room, public ballroom, public lecture room or public exhibition room, or as a public place of assembly for persons admitted thereto, by tickets or otherwise, or used or constructed or adapted to be used, either ordinarily or occasionally, for any other public purpose;

“ slenderness ratio ”, applied to a wall, means the number resulting from dividing the height of the wall by its least overall thickness, and for this purpose the height shall be the clear distance between lateral supports;

“ slop sink ” means a sink intended for receiving solid or liquid filth;

“ superimposed load ” means all loads other than the dead load;

APPLICATION OF BYELAWS.

2.—(1) A person who erects a building shall comply with ^{Buildings.} the requirements of these byelaws, and for the purposes of these byelaws any of the following operations shall be deemed to be the erection of a building:—

(a) the re-erection of any building or part of a building when an outer wall of that building or, as the case may be, that part of a building has been pulled down, or burnt down, to within *ten feet* of the surface of the ground adjoining the lowest storey of the building or of that part of the building;

(b) the re-erection of any frame building or part of a frame building when that building or part of a building has been so far pulled down, or burnt down, as to leave only the framework of the lowest storey of the building or of that part of the building;

(c) the roofing over of any space between walls or buildings.

(2) A person who executes work or instals fittings in connection with a building shall comply with the requirements of ^{Works and fittings.} byelaws 9 to 17 (inclusive) (as to materials) so far as they are applicable, of Part III of these byelaws (which relates to works and fittings) and of Part IV of these byelaws so far as applicable to such matters.

(3) Part II of these byelaws (which relates to buildings), and Part IV of these byelaws so far as applicable to buildings, shall apply to structural alterations or extensions of a building, and a building so far as affected by alterations and extensions, whether the building is erected before or after the date of the operation of these byelaws, and a person making any such structural alteration or extension shall comply with the requirements of these byelaws accordingly. ^{Alterations and extensions.}

(4) Part II of these byelaws (which relates to buildings), and Part IV of these byelaws so far as applicable to buildings, shall apply to a building or a part of a building, whether erected before or after the date of the operation of these byelaws, in a case where a material change within the meaning of section 62 of the Public Health Act, 1936, takes place in ^{Material change of user.}

the purposes for which the building or, as the case may be, a part of the building is used, and a person making such material change shall comply with the byelaws relating to buildings erected for the purpose for which the said building or part of the building is intended to be used.

(5) The provisions of paragraphs (3) and (4) of this byelaw shall not impose requirements in relation to a building which would not have been required if the building had been originally erected, as altered or extended, after the date of the operation of these byelaws.

EXEMPTIONS.

3. The following buildings shall be exempt from the operation of these byelaws:—

Mine
Buildings

(1) a building (not being a dwelling - house) erected in connection with any mine, and used or to be used exclusively for working of the mine;

Moveable
dwellings.

(2) a moveable dwelling to which section 269 of the Public Health Act, 1936, applies;

Buildings
for hop-
pickers,
etc.

(3) a building constructed to be used exclusively for the accommodation of hop-pickers and other persons engaged temporarily in picking, gathering or lifting fruit, flowers, bulbs, roots or vegetables.

4. The following byelaws, except byelaw 7 (as to additional provisions for certain exempted buildings) byelaw 106 (as to alterations, etc. to buildings) and byelaw 143 so far as it requires notice to be given of the intention to erect buildings, the submission of written particulars and notice of a material change of user, shall not apply to—

Poultry-
houses and
aviaries.

(1) a building constructed to be used exclusively as a poultry-house or aviary, if it is wholly detached and distant not less than *ten feet* from every building other than a building specified in this byelaw or in byelaws 5 or 6;

Green-
houses,
coal-sheds,
etc.

(2) a building constructed to be used exclusively as a plant-house, greenhouse, conservatory, orchard-house, summer-house, boat-house not intended for the accommodation of a motor boat, coal-shed, garden tool-house, potting shed or cycle-shed, if it is either—

(a) not more than *one thousand cubic feet* in capacity; or

(b) wholly detached and distant not less than *ten feet* from every building other than a building specified in this byelaw or in byelaws 5 or 6;

(3) a building constructed to be used only in connection with and during the construction, alteration or repair of any building or other work. Builders' sheds, etc.

5. The following byelaws, except byelaw 7 (as to additional provisions for certain exempted buildings), byelaw 98 (as to short-lived materials), byelaw 106 (as to alterations, etc. to buildings), the byelaws with respect to drainage, and byelaw 143 so far as it requires notice to be given of intention to erect buildings, the submission of written particulars, the delivery of plans, and notice of a material change of user, shall not apply to—

(1) a building constructed to be used exclusively as a motor garage or a boat-house intended for the accommodation of a motor boat, and intended for use in connection with a dwelling-house or otherwise not for commercial purposes, if it does not exceed *three hundred square feet* in floor area and either— Garages and motor-boat houses.

(a) the walls and floor (if any) are constructed of incombustible material, and the roof is constructed of or externally covered or internally lined with fire-resisting material; or

(b) it is not fitted with any form of heating apparatus designed or adapted for the combustion of fuel or gas within the building, and is wholly detached and distant not less than *ten feet* from every building other than a building specified in this byelaw or in byelaws 4 or 6, and (where the walls and roof are not constructed of or externally covered or internally lined with fire-resisting material) from the nearest boundary of any adjoining lands or premises;

(2) a building which is not a public building, and is not constructed to be used either wholly or partly for human habitation, or as a place of habitual employment for any person in any manufacture, trade or business, if it— Buildings for storage, agricultural buildings, etc.

(a) does not exceed in height *thirty feet* and does not exceed in capacity *one hundred and twenty-five thousand cubic feet*, and is distant not less than *eight feet* from any street, and not less than *thirty feet* from any building other than a building exempt under this byelaw or byelaws 4 or 6, and from the nearest boundary of any adjoining lands or premises;

(b) exceeds either in height or capacity, but not in both, the figures specified in the last sub-paragraph, and is distant not less than *twenty feet* from any street, and not less than *fifty feet* from any building other than a building exempt under this byelaw or byelaws 4 or 6, and from the nearest boundary of any adjoining lands or premises;

(c) exceeds both in height and capacity the figures specified in sub-paragraph (a) of this paragraph, and is distant not less than *thirty feet* from any street, and not less than *sixty feet* from any building other than a building exempt under this byelaw or byelaws 4 or 6, and from the nearest boundary of any adjoining lands or premises.

6. Part II of these byelaws, except byelaw 98 (as to short-lived materials), shall not apply to—

Buildings
for private
occupation
by day.

(1) a building constructed to be used by day only for private occupation and not for any trade or business, which does not exceed *one thousand cubic feet* in capacity;

Temporary
estate, etc.,
offices.

(2) a building constructed to be used, for a limited period only, in connection with the sale or letting of buildings or building plots in the course of the development of an estate and erected on or in close proximity to the estate.

Additional
provisions
for certain
exempted
buildings.

7. A building which is exempt by byelaw 4, 5 or 6 shall not enclose any gully or channel leading thereto, or any window which is necessary for compliance with byelaws 107 (as to windows) and 112 (as to ventilation of larders) and paragraph (8) of byelaw 132 (as to the lighting and ventilation of internal water closets).

8. The byclaws with respect to sites, foundations and walls shall not apply to a building which is not constructed to be used either wholly or partly for human habitation if—

One storey
buildings
not for
human
habitation.

(1) the building comprises not more than *one* storey; and

(2) the height of the building does not exceed *thirty feet*; and

(3) the capacity of the building does not exceed *eighty thousand cubic feet*; and

(4) the external walls rest on a suitable and sufficient foundation; and

(5) the external walls are so constructed as to provide a suitable degree of fire-resistance; and

(6) the external walls are constructed of sufficient strength to secure due stability; and

(7) the building is distant from the boundary of any adjoining lands or premises (not being a street) not less than—

(a) *ten feet*, where it does not exceed *two thousand cubic feet* in capacity;

(b) *fifteen feet*, where it exceeds *two thousand cubic feet* but does not exceed *fifteen thousand cubic feet* in capacity;

(c) *thirty feet*, where it exceeds *fifteen thousand cubic feet* in capacity.

PART II—BUILDINGS.

MATERIALS USED IN THE CONSTRUCTION OF BUILDINGS.

9.—(1) Every brick and block in a structural wall (including a pier or chimney forming part of the wall) shall be composed of hard well-burned clay or terra-cotta, natural or cast stone, concrete, calcium silicate (in compliance with Class A of British Standard Specification No. 187—1934), or other incombustible material of like hardness and durability, or a combination thereof, and shall be of such size, shape and surface as to permit of proper bonding and jointing.

Bricks and
blocks.

(2) Every such brick and block of concrete shall be suitably matured before it is used.

(3) The volume of solid material in every such brick and block formed with cavities, hollows or perforations (other than an air-brick or a ventilating block) shall be not less than *one-half* of the total volume of the brick or block, and the solid material shall be so disposed that its aggregate width (measured horizontally at right angles to the face of the brick or block as laid) is nowhere less than *one-third* of the width of the brick or block.

Cement.

10. Cement shall be either, but not a mixture of,—

(1) cement complying with British Standard Specification No. 12—1931 for Portland Cement; or

(2) cement complying with British Standard Specification No. 146—1932 for Portland-Blastfurnace Cement; or

(3) High Alumina cement complying with the requirements of British Standard Specification No. 12—1931, as regards tensile strength, soundness and setting time, and of such a fineness that the residue on a No. 170 British Standard sieve does not exceed *twelve per cent.*; or

(4) any other cement not inferior in strength, soundness, durability and suitability to that first mentioned above.

Sand.

11. Sand used for mortar shall be clean, well-graded, and substantially free from pebbles and large particles and material which will pass through a No. 100 British Standard sieve, and shall consist of—

(1) hard natural sand containing not more than *six per cent.* of loam or clay; or

(2) crushed hard rock; or

(3) crushed brick free from old plaster; or

(4) crushed hard furnace clinker free from dust; or

(5) other not less suitable material.

12. Water shall be clean and free from deleterious matter. Water.

13.—(1) Cement mortar shall be composed of cement and sand in the proportion of *one part* of cement to not less than *two* nor more than *four parts* of sand measured by volume of the materials when dry. Cement mortar.

(2) Cement-lime mortar shall be composed of Portland cement or Portland-Blastfurnace cement, and either high calcium lime or true moderately hydraulic lime (either in the form of properly slaked lime putty of normal consistence or sound dry hydrate), and sand. The proportion of cement to lime shall be *one part* of cement to not less than *one* nor more than *three parts* of lime measured by volume of dry cement, dry hydrate or lime putty respectively: the proportion of the mixture of cement and lime to sand shall be *one part* of the mixture to not less than *two* nor more than *four parts* of sand measured by volume. Cement-lime mortar.

(3) Lime mortar shall be composed of sand and either— Lime mortar.

(a) high calcium lime, used either as putty of normal consistence from sound hydrated lime or as sound matured putty of normal consistence from properly run quicklime, in the proportion of *one part* of putty to not less than *two* nor more than *four parts* of sand measured by volume; or

(b) magnesian lime, properly slaked, in the proportion of *one part* of lump quicklime to not less than *two* nor more than *three parts* of sand, measured by volume; or

(c) true moderately hydraulic lime, used as sound dry hydrated lime or properly slaked quicklime, in the proportion of *one part* of hydrated lime or slaked quicklime to not less than *two* nor more than *four parts* of sand, measured by volume; or

(d) eminently hydraulic (lias) lime, properly slaked, in the proportion of *one part* of lime to not less than *two* nor more than *four parts* of sand, measured by volume of the materials when dry.

Black
mortar.

(4) Black mortar shall consist of high calcium lime or hydraulic lime and a filler consisting of clean furnace clinkers reasonably free from unburnt coal, soot or flue refuse, with or without sand. The lime shall be used either as sound dry hydrated lime run to putty of normal consistence, or as properly slaked quicklime run to sound putty of normal consistence, or as fresh quicklime. The lime shall be thoroughly and finely ground with the filler and with water in a suitable mill. The mortar shall be composed of *one part* of lime putty to not less than *two* nor more than *four parts* of the filler measured by volume, or *one part* of fresh quicklime to not less than *four* nor more than *eight parts* of the filler measured by volume.

Aggregate
for rein-
forced
concrete.

14.—(1) (a) Aggregate for reinforced concrete shall be natural siliceous sand or gravel, crushed natural stone, broken brick or suitable blastfurnace slag. It shall be hard, strong and durable and shall be clean and free from clay films and other adherent coatings. It shall contain no coal or coal residues (such as clinker, ashes, coke-breeze, pan-breeze or slag) copper slag, forge breeze, dross, soluble sulphates (such as gypsum) or porous or other materials, in so far as any of such materials are liable to reduce the strength or durability of the concrete or to attack the reinforcement;

(b) fine aggregate shall be of such a size that it will pass through a *three-sixteenths-of-an-inch* mesh. Not more than *three per cent.* by weight shall pass through a No. 100 British Standard sieve;

(c) coarse aggregate shall be of such a size that it will not pass through a *three-sixteenths-of-an-inch* mesh. Where bars are used, the maximum size of coarse aggregate shall be *three-quarters* of the cover or of the minimum clear lateral distance between any two reinforcing bars whichever is the less, except where the minimum clear lateral distance between reinforcing bars is less than *one inch*, in which case the maximum size shall be *one-quarter-of-an-inch* less than such distance. Where expanded metal is used, the maximum size of coarse aggregate shall be *three-quarters* of the clear mesh opening on the shortway of the mesh;

(d) the grading between the limits specified in the last preceding sub-paragraph shall be such as to produce a dense concrete of a consistence that will work readily into position without segregation and without the use of an excessive amount of water.

(2) Aggregate for plain cement concrete or lime concrete shall consist of a proper grading of suitable sizes of such materials as are specified in paragraph (1) of this byelaw, or of other material of like suitability.

Aggregate
for plain
cement
concrete
and lime
concrete.

(3) (a) Steel reinforcement shall comply with the requirements of British Standard Specification No. 785—1938. Expanded metal shall conform with British Standard Specification No. 405—1930;

Reinforce-
ment.

(b) all metal for reinforcement shall, immediately before being surrounded by the concrete, be free from loose mill scale, loose rust, oil, grease, and other matter which will interfere with the proper adhesion of the concrete to the metal.

(4) Cement concrete shall be composed of aggregate and cement (mixed with water) in the following proportions:—

Propor-
tions of
cement and
aggregate
in cement
concrete.

(a) for all load-bearing members in reinforced concrete and for the protective encasement of structural steel and reinforced concrete members—not less than *one hundred and twelve pounds* of cement to every *two-and-a-half cubic feet* of fine aggregate and *five cubic feet* of coarse aggregate, or such proportion of fine aggregate to coarse aggregate as will produce a concrete of a compressive strength not less than *three thousand three hundred and seventy-five pounds per square inch* when tested in accordance with the standard method of making preliminary cube tests of concrete set out in Appendix VII to the Report of the Reinforced Concrete Structures Committee of the Building Research Board, dated July, 1933;

(b) for covering the site of a building—not less than *one hundred and twelve pounds* of cement to every *three-and-a-half cubic feet* of fine aggregate and *seven cubic feet* of coarse aggregate;

(c) for foundations, the support or protection of drains, and similar purposes—not less than *one hundred and twelve pounds* of cement to every *fifteen cubic feet* of coarse and fine aggregate in combination.

Proportions
of lime and
aggregate
in lime
concrete.

(5) Lime concrete shall be composed of aggregate and eminently hydraulic (lias) lime, properly slaked, in the proportion of not less than *one hundred and twelve pounds* of quicklime to every *five cubic feet* of coarse and fine aggregate in combination.

Mixing and
depositing
of concrete.

(6) (a) The quantity of water for reinforced concrete shall be sufficient only to produce a consistence to enable the concrete to surround, cover, embed and grip adequately all the reinforcement;

(b) the quantity of water for making plain cement concrete or lime concrete shall be sufficient only to produce a concrete mixture of a uniform colour and to ensure that the concrete shall be suitable for its purpose;

(c) the concrete shall be so mixed as to secure uniform distribution of the materials throughout the mixture;

(d) the concrete shall be deposited without segregation of the materials, and all voids shall be filled by punning, rodding, vibrating or other means of consolidation after the concrete has been deposited and before it has begun to set;

(e) where formwork is employed, it shall be sufficiently rigid to retain the concrete in position and shape during depositing and consolidation;

(f) after the concrete has been consolidated and during setting, it shall remain undisturbed and shall be protected from the effect of frost, heat, running water, evaporation, vibration or any other cause which may reduce its strength or tend to form voids in it;

(g) during mixing, depositing and setting, the temperature of the concrete shall not be allowed to fall below *forty degrees Fahrenheit*.

15.—(1) Material used for a damp-proof course shall be durable and impervious to moisture, and when placed in a wall shall be capable of withstanding the dead load of the wall and all superimposed loads on the wall and all horizontal and inclined forces in such a manner as will not impair the efficiency of the damp-proof course and will not allow such movement of the wall as may lead to instability of any part of the structure.

Damp-
proof
courses.

(2) The requirements of this byelaw shall be deemed to be satisfied by—

(a) two or more courses of slates laid so as to break joint and bedded in cement mortar; or

(b) a layer of sheet lead weighing not less than *four pounds per square foot* completely embedded in lime mortar, any joint being overlapped to the extent of not less than *three inches*; or

(c) a layer of soft-tempered sheet copper weighing not less than *one pound per square foot* bedded in lime mortar or cement mortar or cement-lime mortar, any joint being overlapped to the extent of not less than *three inches*; or

(d) two or more courses of blue bricks or other engineering bricks which are incapable of absorbing more than *three per cent.* of moisture when submerged for *twenty-four hours* after previous drying at *one hundred and five degrees Centigrade*, bedded in cement mortar; or

(e) asphalte, or other bituminous material conforming to and laid in accordance with British Standard Specification No. 743—1937.

16. The steel in every structural element in a building shall—

Structural
steel.

(1) as rolled, be not inferior in strength and suitability to steel complying with British Standard Specification No. 15—1936 for Structural Steel; and

(2) be free from loose mill scale, loose rust, and other deleterious matter.

Timber. *17. Timbers shall be of a quality and strength sufficient for its purpose and shall be well-seasoned, sound, and free from rot, worm, beetle and vermin. It shall not contain large, loose or dead knots, splits or other defects to such an extent and so situated in the piece as to render it insufficient in strength or stiffness.

SITES.

Drainage of subsoil. 18.—(1) The subsoil of the site of a building (other than a building of the warehouse class intended to be used wholly or principally for storage or the accommodation of plant) shall, wherever the dampness or position of the site renders the precaution necessary, be effectually drained, or such steps shall be taken by the construction of a layer of impervious material upon the site as will effectually protect the building from damp arising from the subsoil.

(2) Where, during the making of any excavation for a building, any existing subsoil drain is severed, sufficient precautions shall be taken to prevent the drain from causing dampness of the site of the building.

Prevention of damp. 19. The ground surface enclosed within the external walls of a domestic building shall be cleared of vegetation and shall, unless the exceptional condition of the site or exceptional nature of the soil renders this requirement unnecessary, be—

(1) properly asphalted; or

(2) covered with a layer of spade-finished cement concrete, at least *six inches* thick, or *four inches* thick if properly laid on a bed of clinker, broken brick or similar material; or

(3) covered in a suitable manner with some not less suitable material.

* In administering the requirement as to strength in this byelaw, the Council will accept sizes calculated from the rules in the byelaws made by the London County Council for the use of timber in buildings.

20. Where the intended site of a building (other than a building of the warehouse class intended to be used wholly or principally for storage or the accommodation of plant) forms or has formed part of a clay-pit, or where by reason of excavation the whole or part of such site requires raising to prevent dampness in the building, the site or the part of the site, as the case may require, shall be raised to an adequate height by the deposit of layers of sound and suitable material, properly consolidated.

Elevation
of sites.

FOUNDATIONS.

21. The foundations of every building shall be—

Founda-
tions of
buildings.

(1) so constructed as to sustain the combined dead load of the building and the superimposed load and to transmit those loads to the subsoil in such a manner that the pressure on the subsoil shall not cause such settlement of the building or any part of the building as may impair its stability; and

(2) taken down to such a depth or so constructed as to render the building immune from damage from movements due to seasonal variations in the content of moisture in the ground.

22.—(1) Every structural wall (including a pier forming part of the wall) shall rest upon—

Founda-
tions of
structural
walls.

(a) solid undisturbed rock; or

(b) a layer of cement concrete of sufficient width and thickness; or

(c) proper footings of sufficient width built directly on suitable ground; or

(d) proper footings built on a layer of cement concrete of sufficient width and thickness; or

(e) proper footings built on a layer of lime concrete of sufficient width and thickness; or

(f) a sufficient raft of cement concrete properly constructed and where necessary suitably reinforced; or

(g) a layer of cement concrete of sufficient width and thickness on suitable piles driven to a proper depth; or

(h) a bressummer of sufficient strength; or

(i) some other not less sufficient substructure as a foundation.

(2) In the case of a domestic building the walls of which are constructed otherwise than with framework, the requirements of sub-paragraphs (b), (c) and (d) of paragraph (1) of this byelaw shall, where the wall is not more than *fifty feet* high and the bearing capacity of the ground under its foundation is not inferior to that of firm clay, coarse sand, or confined sand, be deemed to be satisfied if—

(a) (i) the width of the bottom of the foundation (except where an adjoining wall or pier interferes) is not less than *twelve inches* or not less than *twice* the thickness of the wall in the lowest storey, whichever is the greater; and

(ii) where there is a pier forming part of the wall, the foundation is carried round the pier on all sides so as to project at least to the same extent as it projects beyond the wall; and

(b) the foundation is situated centrally under the wall or pier (except where an adjoining wall or pier interferes); and

(c) the height from the bottom of the foundation to the base of the wall or pier is not less than *nine inches* or not less than *one and one-third* times the projection of the foundation from the base, whichever is the greater; and

(d) where there are footings of brickwork, the footings—

(i) are built in cement mortar; and

(ii) are either in regular offsets from the face of the wall or pier or in one offset; and

(iii) where they are built directly upon the ground, and the wall is more than *nine inches* thick, have a further course of brickwork at the bottom of the footings; and

(e) where there are footings built upon cement concrete, the thickness of the concrete is not less than *one and one-third* times the projection of the concrete from the footings.

Founda-
tions of
piers, etc.

23. A structural pier, stanchion, column or post which does not form part of a wall shall rest upon one of the foundations specified in paragraph (1) of the last preceding byelaw.

WALLS.

24. Byelaws 25 to 54 (as to the construction of walls), Application of byelaws to structural walls. except when otherwise stated or unless the context otherwise requires, apply to the structural walls of a building (not being a chimney shaft which is structurally independent and erected in connection with a building of the warehouse class).

25. Byelaws 26 to 52 (as to the construction of walls) except Exception for certain domestic buildings. byelaws 35 (as to damp-proof courses) and 51 (as to coping) shall not apply to a domestic building if—

(1) the building comprises not more than *two* storeys; and

(2) the capacity of the building does not exceed *thirty-six thousand cubic feet*; and

(3) each external wall of the building is constructed of good and suitable material so as to be of sufficient stability and reasonably weatherproof and either—

(a) to a height not less than *six inches* above the surface of the adjoining ground is constructed of—

(i) bricks or blocks not less than *eight-and-a-half inches* thick properly bonded and solidly put together with mortar; or

(ii) other good hard and suitable incombustible material of sufficient thickness properly and solidly put together; or

(b) at a height not less than *six inches* above the surface of the adjoining ground is carried upon sufficient piers; and

(4) the building is distant from the boundary of any adjoining lands or premises (not being a street and not comprising buildings forming part of the same block) not less than—

(a) *five feet*, if the capacity of the building does not exceed *eighteen thousand cubic feet*, or *ten feet*, if the capacity is greater, where the external walls are constructed of incombustible material, or with framework of incombustible material, or of oak, teak or other hard timber either alone or in combination with incombustible material, or with framework which is either filled with or externally covered with incombustible material;

(b) *ten feet*, if the capacity does not exceed *eighteen thousand cubic feet*, or *twenty feet*, if the capacity is greater, where the external walls are not so constructed; and

(5) where the building forms or is intended to form part of a block of buildings—

(a) the number of buildings in the block does not exceed *four*; and

(b) no building in the block exceeds *eighteen thousand cubic feet* in capacity; and

(c) the buildings are separated by walls which notwithstanding anything hereinbefore contained are constructed in accordance with the requirements of the byelaws with respect to party walls; and

(d) where there are more than *two* buildings in the block, their external walls are constructed of incombustible material, or with framework of incombustible material, or of oak, teak or other hard timber either alone or in combination with incombustible material, or with framework which is either filled with or externally covered with incombustible material.

Special Classes of Walls.

Exception for special classes of walls.

26.—The *General Byelaws as to the Construction of Walls*, except byelaw 52 (as to additional provisions as to party walls), shall not apply to the walls provided for in byelaws 27, 28 and 29, except in so far as they are expressly applied.

One storey walls (pier construction).

27. A wall or part of a wall which does not exceed *one* storey in height and is constructed with piers of bricks or blocks or other hard and incombustible material shall comply with the following requirements:—

(1) the piers shall be properly distributed throughout its length, and be of sufficient size and strength;

(2) the spaces between the piers, in the case of a public building or a domestic building, shall be filled with bricks or blocks or other hard and incombustible material, and, in the case of a building of the warehouse class, shall be filled or covered with material giving a suitable degree of fire-resistance, the filling or covering in either case to be of sufficient thickness to secure due stability;

(3) where the wall is a wall of a public building or a domestic building or a building of the warehouse class in which persons are intended to be habitually employed in any manufacture, trade or business, it shall satisfy byelaw 35 (as to damp-proof courses) and byelaw 51 (as to coping), and, if it is an external wall, shall be so constructed or treated as to be reasonably weatherproof.

28.—(1) Every part of a wall with a structural framework of steel, iron or reinforced concrete shall be so constructed that—

Walls with a structural framework of steel, iron or reinforced concrete.

(a) the wall shall be capable of safely sustaining and transmitting the dead loading and the superimposed loading to which it may be subjected calculated in accordance with the First Schedule to these byelaws so far as it is applicable, and the horizontal and inclined forces to which it may be subjected, without undue settlement or deflection and without exceeding the appropriate limits of stress for the materials of which it is constructed;

(b) the wall shall be durable;

(c) the wall shall possess a degree of fire-resistance appropriate to the purpose for which the building is intended to be used;

(d) the spaces of the framework shall be filled with panels of, or externally covered with, hard and incombustible material, which shall be properly secured to the framework and, where the wall is an external wall, be reasonably weatherproof.

(2) Where the framework is of steel, the requirements of this byelaw, so far as it relates to framework, shall be deemed to be satisfied—

(a) as regards structural stability, if every element of the framework is designed in accordance with the rules set out in British Standard Specification No. 449—1937 for the Use of Structural Steel in Building;

(b) as regards durability, if the framework is protected against corrosion by a sufficient encasement of concrete or by a suitable coating of paint or bitumen;

(c) as regards fire-resistance, in the case of a domestic building the uppermost floor of which is not more than *forty feet* above the adjoining ground, if the framework is encased in one of the following materials of the thickness specified below, except at rivet heads, angle cleats, plate covers and similar places, and, except where otherwise provided, all re-entrant spaces are filled with concrete or other not less suitable material properly bonded or tied into the encasement:—

concrete, of the quality specified for the protective encasement of structural steel in the byelaws with respect to materials, not less than *one-and-a-half inches* thick;

solid bricks of clay or calcium silicate or solid pre-cast concrete blocks, in which the courses are properly bonded and secured, not less than *two inches* thick;

suitable hollow blocks of clay or concrete properly bonded, anchored or tied, not less than *two inches* thick;

suitable hollow gypsum tiles, properly bonded, anchored or tied, not less than *two inches* thick;

solid gypsum tiles, properly bonded, anchored or tied, not less than *one inch* thick;

Portland cement rendering or gypsum plaster, on a suitable metallic mesh, not less than *one inch* thick, the re-entrant spaces not being filled.

(3) Where the framework is of reinforced concrete, the requirements of this byelaw, so far as it relates to framework, shall be deemed to be satisfied, as regards structural stability and durability, if every element of the framework is designed in accordance with the rules set out in the Report of the Reinforced Concrete Structures Committee of the Building Research Board, dated July, 1933.

(4) The requirements of this byelaw, so far as it relates to the panels in any external wall of a domestic building, shall be deemed to be satisfied, in the case of single-leaf panels, if the panels are not less than *eight-and-a-half-inches* thick exclusive of any plaster, and are constructed of solid or hollow bricks or blocks of clay, concrete, calcium silicate, natural stone or cast stone, or a combination of any of those materials securely bonded or tied together.

29. A wall built of cement concrete or reinforced concrete shall be so constructed as to secure due stability, and if it is an external wall shall be reasonably impervious to moisture.

Walls of cement concrete or reinforced concrete.

General Byelaws as to the Construction of Walls.

30. Subject to the provisions of the next two succeeding byelaws, every external wall and every party wall of a building (including piers forming part of the wall) and every cross wall which in pursuance of the provisions of these byelaws may be deemed a means for determining the length of any external wall or party wall, shall be constructed of bricks or blocks properly bonded and solidly put together with mortar, or other good hard and suitable incombustible material properly and solidly put together.

Construction of walls (general).

31.—(1) An external wall or part of an external wall of a domestic building, which comprises not more than *three* storeys and does not form part of a block of more than *four* domestic buildings, may be constructed from a height not less than *six inches* above the level of the adjoining ground with framework of timber, or of timber in combination with incombustible material, and if so constructed it shall comply with the following requirements:—

Special provision as to certain domestic buildings comprising not more than three storeys.

(a) the framework shall be of sufficient size and strength to secure due stability and be properly framed together;

(b) every party wall shall be carried out at least to the external face of any framework in any adjoining external wall;

(c) the framework shall be filled with suitable incombustible material reasonably weatherproof and properly secured to the framework, except where the wall or part of

a wall is constructed as a bay for a bay window above the level of the lowest window opening in the bay, or as a gable above the level of the floor of the topmost storey of the building, when the framework may be externally covered with tiles, slates or other equally suitable incombustible material in such a manner that the wall or part of a wall is reasonably weatherproof;

(d) the wall or part of a wall shall be distant from the boundary of any adjoining lands or premises (not being a street and not being lands or premises comprising buildings forming part of the same block) not less than—

(i) *eight feet*, where the building comprises *one* or *two* storeys; or

(ii) *sixteen feet*, where the building comprises *three* storeys; or

(iii) *half* these distances, where the wall or part of a wall comprises, or forms part of, a bay or gable only, or its framework is of oak, teak or other hard timber either alone or in combination with incombustible material;

(e) below the part constructed with framework, the wall shall be constructed in the same manner as if it were constructed throughout its whole height of bricks or blocks or other good hard and suitable incombustible material.

(2) Byelaw 44 (as to the thickness of walls not built in horizontal courses) shall not apply to a wall or part of a wall constructed in accordance with this byelaw.

Special
provision
as to
certain
buildings
of the
warehouse
class.

32.—(1) An external wall or part of an external wall of a building of the warehouse class may be constructed from a height not less than *six inches* above the level of the adjoining ground with framework of timber, and if so constructed it shall comply with the following requirements:—

(a) every part of the building shall be distant not less than *fifty feet* from the boundary of any adjoining street or lands, or premises comprising buildings, and from every other building;

(b) the building shall be so constructed as to have a suitable degree of fire-resistance;

(c) the framework shall be of sufficient size and strength to secure due stability and be properly framed together;

(d) the covering or filling (if any) of the framework shall be reasonably weatherproof and properly secured to the framework;

(e) below the part constructed with framework, the wall shall be constructed in the same manner as if it were constructed throughout its whole height of bricks or blocks or other hard and suitable incombustible material.

(2) Byelaw 44 (as to the thickness of walls not built in horizontal courses) shall not apply to a wall or part of a wall constructed in accordance with this byelaw.

33. Where any wall or any part of a wall is constructed as a ^{Hollow} hollow wall—
walls.

(1) the cavity between the inner and outer parts of the wall shall throughout be of a width not exceeding *three inches*;

(2) the cavity shall be carried down not less than *six inches* below the level of the damp-proof course, or sufficient precautions shall be taken as near as practicable to the bottom of the cavity effectually to prevent moisture from passing from the outer part to the inner part of the wall;

(3) the inner and outer parts of the wall shall be securely tied together with suitable bonding ties of adequate strength formed of galvanized iron, iron tarred and sanded, glazed stoneware, copper, bronze or other not less suitable material, the ties being placed at distances apart not exceeding *three feet* horizontally and *eighteen inches* vertically;

(4) the inner and outer parts of the wall shall each be not less than *four inches* thick throughout, except that in a wall not exceeding *twenty-five feet* in length and *twenty feet* in height, which forms part of a building of not more than *two* storeys, the thickness of each part may

be not less than *three inches* throughout if all courses of less height than *six inches* are put together with cement mortar or with cement-lime mortar of the strongest mixture prescribed by the byelaw in that behalf or the wall has at least *twice* the number of ties required by the preceding paragraph;

(5) the cavity may be reckoned as part of the thickness prescribed for walls by these byelaws where such thickness does not exceed *eight-and-a-half inches* but shall not be so reckoned where such thickness exceeds *eight-and-a-half inches*.

Woodwork
in hollow
walls or
walls of
hollow
blocks.

34. Where a wall or part of a wall is constructed as a hollow wall or with hollow blocks, all woodwork inserted in the wall so as to project into or extend across a cavity shall be effectually protected on the upper side with a layer of sheet lead or other equally suitable material impervious to moisture.

Provision
of damp-
proof
courses.

35.—(1) Every wall (whether a structural wall or not) of a public building or domestic building, or a building of the warehouse class in which persons are intended to be habitually employed in any manufacture, trade or business (including a pier forming part of the wall) shall be provided with a damp-proof course at a height of not less than *six inches* above the surface of the ground adjoining the wall or pier and—

(a) beneath the level of the under side of the lowest timbers resting on the wall;

(b) where there is a solid floor, not higher than the level of the upper surface of the concrete or other similar solid material forming the structure of the floor and beneath the level of the under side of all boards, planks, wood blocks and other wood laid or bedded upon or in the concrete or other material and carried up on the inner face of the wall to the under side of the flooring;

(c) where a site or building is required by these byelaws to be raised, not lower than the height so required.

(2) Where any part of a floor of the lowest or only storey of the building, not being a cellar for storage only, is below the surface of the adjoining ground, and a wall or part of a wall of the storey is in contact with the ground—

(a) the wall or part of a wall shall be constructed so as to be impervious to moisture, or as a hollow wall in accordance with the byelaws in that behalf, from its base to a height of not less than *six inches* above the surface of the ground; and

(b) an additional damp-proof course shall be inserted in the wall or part of the wall either at its base or, where it is a hollow wall, as near as practicable to its base but in no case less than *six inches* above the base.

(3) Every wall of the building which is carried up above a flat or gutter so as to form a parapet shall be provided with a damp-proof course above and as near as practicable to the covering of the roof adjoining the wall.

36.—(1) In the case of a private dwelling-house, and in the case of other buildings where walls are constructed of hard and incombustible material other than bricks or blocks laid in horizontal beds or courses, every wall or part of a wall shall be constructed in accordance with byelaws 37 to 44 (as to the thickness of walls).

Thickness
of walls of
brickwork
or masonry.

(2) In the case of a building (other than a private dwelling house), where walls are constructed of bricks or blocks laid in horizontal beds or courses, every wall or part of a wall shall either—

(a) be constructed in accordance with byelaws 37 to 43 (as to the thickness of walls); or

(b) be so designed and constructed as to be capable of safely sustaining and transmitting the dead loading and the superimposed loading to which it may be subjected calculated in accordance with the First Schedule to these byelaws so far as it is applicable, and the horizontal and inclined forces to which it may be subjected, without undue settlement or deflection and without exceeding the intensity of pressure on the material shown in the appropriate Tables in the Second Schedule to these byelaws determined in the manner specified in that Schedule.

37. For the purpose of the following byelaws relating to the thickness of walls, the height of storeys and the height and length of walls shall be measured in accordance with the following rules:—

Rules for
measuring
height of
storeys and
height and
length of
walls.

(1) the height of the lowest or only storey shall be measured from the base of the wall, and

the height of any other storey shall be measured from the level of the under side of the floor-structure of the storey,

to the level of the under side of the floor-structure of the storey next above it or, if there is no such storey, then to the highest part of the wall or in a storey comprising a gable to *half* the height of the gable;

(2) the height of a wall shall be measured from its base to the base of the gable in a party wall comprising a gable, to *half* the height of the gable in any other wall comprising a gable, and to the highest part (excluding any parapet) in any other wall;

(3) walls shall be deemed to be divided into distinct lengths by—

(a) return walls which are external walls, party walls or cross walls, of a height equal to the height of the wall so deemed to be divided and of the thickness prescribed by the byelaws, or of such other height and thickness as will give at least equal strength and stability, and are bonded with or otherwise securely tied into the walls so deemed to be divided; or

(b) piers of a height equal to the height of the wall so deemed to be divided and of a breadth not less than *twice* the thickness of the wall so deemed to be divided, projecting on each side of the wall for a distance not less than the thickness of the wall or on one side of the wall for a distance not less than *twice* the thickness of the wall, or by piers of such other dimensions and height as will give not less strength and stability;

(4) the length of a wall shall be measured from the centre of one return wall or pier to the centre of another, or to the end of the wall if there is no return wall or pier;

(5) for the purpose of these rules—

(a) a wall shall not be deemed a cross wall unless it is carried up to the top of the wall deemed to be divided by it or, if that wall comprises a gable, to the level of the base of the gable, and unless in each storey the aggregate extent of the vertical faces or

elevations of all the recesses and that of all the openings therein, taken together, does not exceed *one-half* of the whole extent of the vertical face or elevation of the wall in such storey;

(b) a chimney, or two chimneys built back-to-back, may be reckoned as a pier if—

(i) the least horizontal sectional area of solid material in the jambs and in the chimney breast or breasts, added together, are not less than the area required for a pier by paragraph (b) in rule (3); and

(ii) the thickness of the back of the fireplace opening, or of the back common to two fireplace openings built back-to-back, is not less than the thickness of the wall deemed to be divided.

38.—(1) In the case of a domestic building, every external wall and every party wall built of bricks or blocks laid in horizontal beds or courses shall, subject to the provisions of the succeeding paragraphs of this byelaw and to the provisions of byelaws 40 (as to reinforced brickwork or masonry), 41 (as to pier construction) and 42 (as to recesses, bays, etc.), be constructed of at least the thicknesses specified in column 3 of the Table in this byelaw, set opposite the particulars in columns 1 and 2 of the Table specifying the height and length of the wall:—

1 Height of wall.	2 Length of wall.	3 Thickness of wall.
Not exceeding 15 ft. Exceeding 15 ft. but not exceeding 25 ft.	Whatever the length. Not exceeding 30 ft. Exceeding 30 ft.	8½ in. for the whole of its height. 8½ in. for the whole of its height. 13 in. from the base for the height of 1 storey. 8½ in. for the rest of its height.
Exceeding 25 ft. but not exceeding 30 ft.	Not exceeding 25 ft. Exceeding 25 ft. but not exceeding 35 ft. Exceeding 35 ft.	8½ in. for the whole of its height. 13 in. from the base for the height of 1 storey. 8½ in. for the rest of its height. 13 in. from the base for the height of 2 storeys. 8½ in. for the rest of its height.

Thickness
of walls
(domestic
buildings).

1 Height of wall.	2 Length of wall.	3 Thickness of wall.
Exceeding 30 ft. but not exceeding 40 ft.	Not exceeding 35 ft.	13 in. from the base for the height of 2 storeys. 8½ in. for the rest of its height.
	Exceeding 35 ft.	17½ in. from the base for the height of 1 storey. 13 in. for the height of the next 2 storeys. 8½ in. for the rest of its height.
Exceeding 40 ft. but not exceeding 50 ft.	Not exceeding 35 ft.	17½ in. from the base for the height of 1 storey. 13 in. for the height of the next 2 storeys. 8½ in. for the rest of its height.
	Exceeding 35 ft. but not exceeding 45 ft.	17½ in. from the base for the height of 2 storeys. 13 in. for the rest of its height.
	Exceeding 45 ft.	22 in. from the base for the height of 1 storey. 17½ in. for the height of the next storey. 13 in. for the rest of its height.
Exceeding 50 ft. but not exceeding 60 ft.	Not exceeding 45 ft.	17½ in. from the base for the height of 2 storeys. 13 in. for the rest of its height.
	Exceeding 45 ft.	22 in. from the base for the height of 1 storey. 17½ in. for the height of the next 2 storeys. 13 in. for the rest of its height.
Exceeding 60 ft. but not exceeding 70 ft.	Not exceeding 45 ft.	22 in. from the base for the height of 1 storey. 17½ in. for the height of the next 2 storeys. 13 in. for the rest of its height.
	Exceeding 45 ft.	The above thicknesses shall be increased by 4 in. in each storey below the uppermost 2 storeys.
Exceeding 70 ft. but not exceeding 80 ft.	Not exceeding 45 ft.	22 in. from the base for the height of 1 storey. 17½ in. for the height of the next 3 storeys. 13 in. for the rest of its height.
	Exceeding 45 ft.	The above thicknesses shall be increased by 4 in. in each storey below the uppermost 2 storeys.

1 Height of wall.	2 Length of wall.	3 Thickness of wall.
Exceeding 80 ft. but not exceeding 90 ft.	Not exceeding 45 ft.	26 in. from the base for the height of 1 storey. 22 in. for the height of the next storey. 17½ in. for the height of the next 3 storeys. 13 in. for the rest of its height.
Exceeding 90 ft.	Exceeding 45 ft.	The above thicknesses shall be increased by 4 in. in each storey below the uppermost 2 storeys.
Exceeding 90 ft.	Not exceeding 45 ft.	26 in. from the base for the height of 1 storey. 22 in. for the height of the next 2 storeys. 17½ in. for the height of the next 3 storeys. 13 in. for the rest of its height.
Exceeding 90 ft.	Exceeding 45 ft.	The above thicknesses shall be increased by 4 in. in each storey below the uppermost 2 storeys.

(2) A wall, the height of which in any storey of a building comprising more than *one* storey exceeds *sixteen* times the thickness hereinbefore prescribed, shall throughout that storey be increased in thickness to *one-sixteenth* of the height of the storey, and the thickness throughout any lower storey or storeys shall be proportionately increased.

(3) A wall of an out-building not communicating directly with the building to which it is appurtenant, if the wall does not exceed *nine feet* in height and *ten feet* in length and is properly put together with cement mortar, or with cement-lime mortar of the strongest mixture prescribed by the byelaw in that behalf, may be not less than *four inches* thick.

39.—(1) In the case of a public building or a building of the warehouse class, every external wall and every party wall built of bricks or blocks laid in horizontal beds or courses shall, subject to the provisions of paragraph (2) of this byelaw and to the provisions of byelaws 40 (as to reinforced brickwork or masonry), 41 (as to pier construction) and 42 (as to recesses, bays, etc.), be constructed of at least the thicknesses specified hereunder:—

Thickness of walls (public buildings and buildings of warehouse class).

(a) the thickness at the base of the wall shall be the thickness specified in column 3 of the Table in this byelaw, set opposite the particulars in columns 1 and 2 of the Table specifying the height and length of the wall;

(b) the thickness immediately below *sixteen feet* from the top of the wall shall be the thickness specified in column 4 of the Table opposite the before-mentioned particulars in columns 1 and 2;

(c) the intermediate part of the wall between the base and *sixteen feet* below the top shall be built so as to fill at least the space between straight lines drawn on each side of the wall and joining the thickness at the base to the thickness immediately below *sixteen feet* from the top;

(d) for *sixteen feet* from the top of the wall, the thickness shall be *thirteen inches*:

Provided that, where the wall does not exceed *thirty feet* in height, the wall for *eleven feet six inches* from the top may be *eight-and-a-half inches* thick.

1 Height of wall	2 Length of wall.	3 Thickness at base.	4 Thickness immediately below 16 feet from the top.
Not exceeding 25 ft.	Whatever the length.	13 in.	13 in.
Exceeding 25 ft. but not exceeding 30 ft.	Not exceeding 45 ft.	13 in.	13 in.
Exceeding 30 ft. but not exceeding 40 ft.	Exceeding 45 ft.	17½ in.	13 in.
	Not exceeding 35 ft.	13 in.	13 in.
Exceeding 40 ft. but not exceeding 50 ft.	Exceeding 35 ft. but not exceeding 45 ft.	17½ in.	13 in.
	Exceeding 45 ft.	22 in.	13 in.
	Not exceeding 30 ft.	17½ in.	13 in.
Exceeding 50 ft. but not exceeding 60 ft.	Exceeding 30 ft. but not exceeding 45 ft.	22 in.	13 in.
	Exceeding 45 ft.	26 in.	13 in.
	Not exceeding 45 ft.	22 in.	13 in.
Exceeding 60 ft. but not exceeding 70 ft.	Exceeding 45 ft.	26 in.	13 in.
	Not exceeding 45 ft.	22 in.	13 in.
Exceeding 70 ft. but not exceeding 80 ft.	Exceeding 45 ft.	26 in.	17 in.
	Not exceeding 45 ft.	22 in.	13 in.
Exceeding 80 ft. but not exceeding 90 ft.	Exceeding 45 ft.	26 in.	17 in.
	Not exceeding 45 ft.	26 in.	13 in.
Exceeding 90 ft.	Exceeding 45 ft.	30 in.	17 in.
	Not exceeding 45 ft.	26 in.	13 in.
	Exceeding 45 ft.	30 in.	17 in.

(2) A wall, the height of which in any storey of a building comprising more than *one* storey exceeds *fourteen* times the thickness hereinbefore prescribed, such thickness being measured at a height above the surface of the floor equal to *two-thirds* of the total height of that storey, shall throughout that storey be increased in thickness to *one-fourteenth* of the height of that storey, and the thickness throughout any lower storey or storeys shall be proportionately increased.

40. Any external wall or party wall built of bricks or blocks, properly reinforced and properly bonded and solidly put together with cement mortar, or with cement-lime mortar of the strongest mixture prescribed by the byelaw in that behalf, may be reduced in thickness by not more than *four-and-a-half inches* but not so as to be of less thickness than *eight-and-a-half inches*.

Thickness
of rein-
forced
brickwork
or masonry.

41. Where a wall is required by byelaw 38 (as to the thickness of walls of domestic buildings) or byelaw 39 (as to the thickness of walls of public buildings and buildings of the warehouse class) to be more than *eight-and-a-half inches* thick, the additional thickness may be confined to piers properly distributed throughout its length, if either—

Thickness
(pier con-
struction).

(1) (a) the thickness of the wall between the piers is not less than *one-half* of the required thickness; and

(b) the collective width of the piers amounts to *one-quarter* of the length of the wall, it being permitted to reduce the width of any pier of which the horizontal sectional area is not diminished if the width of the pier is not less than that required to give the necessary area when the projection is *one-third* of the width; or

(2) (a) piers are placed at the ends of the wall; and

(b) the mean thickness of the wall, including the piers, is not less in any storey than the thickness hereinbefore prescribed for such wall for such storey.

42. The provisions of byelaws 38 (as to the thickness of walls of domestic buildings) and 39 (as to the thickness of walls of public buildings and buildings of the warehouse class) shall not apply to—

Thickness
(recesses,
bays, etc.).

(1) any portion of a wall which is recessed or chased, or forms part of a chimney constructed in accordance with the byelaws with respect to chimneys;

(2) any part of an external wall which is constructed as a bay for a bay window, or as a gable, of bricks or blocks of such thickness as shall be necessary to secure due stability, properly and solidly put together with cement mortar, or with cement-lime mortar of the strongest mixture prescribed by the byelaw in that behalf, and is, as the case may be, above the level of the sill of the lowest window opening in such bay or above the level of the floor of the topmost storey in such building.

Thickness
of cross
walls.

43.—(1) Every cross wall built of bricks or blocks laid in horizontal beds or courses, which in pursuance of these byelaws may as a return wall be deemed a means of determining the length of any external wall or party wall of a building, shall, except where it forms part of a chimney constructed in accordance with the byelaws relating to chimneys and subject to paragraphs (2) and (3) of this byelaw, be of a thickness of at least *two-thirds* of that prescribed by the preceding byelaws for an external wall or a party wall of the same height and length and belonging to the same class of building, but shall be not less than *eight-and-a-half inches* thick.

(2) Where the building is intended to be used as a dwelling-house, and the external wall which is deemed to be divided into distinct lengths by the cross wall does not exceed *twenty feet* in height and *thirty-five feet* in length, the cross wall may be not less than *four inches* thick.

(3) A cross wall which supports a superincumbent external wall shall be of a thickness not less than that prescribed by the preceding byelaws for an external wall or a party wall of the same height and length and belonging to the same class of building.

Thickness
of walls not
built in
horizontal
courses.

44. The following requirements shall regulate the thickness of every external wall, every party wall, and every such cross wall as is referred to in the last preceding byelaw, where the wall is constructed of material other than bricks or blocks laid in horizontal beds or courses:—

(1) a wall built of stone, or of clunches of bricks or other burnt or vitrified material, or of flintwork, shall be *one and one-third* times the thickness prescribed by the byelaw in that behalf for a wall built of bricks or blocks in horizontal courses, and of the same description, height and length, and belonging to the same class of building;

(2) a wall built of brickwork and flintwork, in which the proportion of brickwork is not less than *one-fifth* of the entire content of the wall and is properly distributed in piers and horizontal courses, or built of other suitable material not specifically mentioned in this byelaw, shall be of the thickness prescribed by the byelaw in that behalf for a wall built of bricks or blocks in horizontal courses, and of the same description, height and length, and belonging to the same class of building;

(3) where the preceding paragraphs of this byelaw require a wall to be more than *eight-and-a-half inches* thick, the additional thickness may be confined to piers properly distributed throughout its length, if—

(a) piers are placed at the ends of the wall; and

(b) the mean thickness of the wall, including the piers, is not less in any storey than the thickness hereinbefore prescribed for the wall for that storey.

45. Where a recess is made in an external wall or a party ^{Recesses.} wall—

(1) the wall at the back of the recess shall be not less than *eight-and-a-half inches* thick;

(2) a sufficient arch or lintel of incombustible material shall be built in every storey over the recess;

(3) in each storey the aggregate extent of recesses causing the wall at the back to be of less thickness than that prescribed by these byelaws shall not exceed *one-half* of the superficial extent of the wall;

(4) that side of the recess which is the nearer to the inner face of a return external wall shall be distant not less than *thirteen inches* therefrom.

- Chases.** 46. A chase made in an external wall or a party wall shall—
- (1) be not less than *seven feet* from every other chase on the same side of the wall;
 - (2) be not less than *thirteen inches* from any other chase and from any return wall;
 - (3) be not more than *fourteen inches* wide;
 - (4) be not more than *four-and-a-half inches* deep from the face of the wall;
 - (5) leave the wall at the back not less than *eight-and-a-half inches* thick.

- Openings.** 47.—(1) Where there is left in an external wall an opening of greater extent than *one-half* of the vertical elevation of the storey or storeys in which the opening is left, sufficient supports so disposed as to carry the superstructure and so constructed as to give a suitable degree of fire-resistance shall be provided.
- (2) Where there is any other opening in an external wall, or any opening in any other wall, the part of the wall which is directly above the opening shall be properly and adequately supported.

- Bressummers, etc.** 48. Every bressummer and every main beam supporting a floor or roof shall—
- (1) be borne by a sufficient template of stone, iron, terra-cotta, vitrified stoneware or other not less suitable material, of at least the full breadth of the bressummer or beam, and shall have a bearing in the direction of its length of not less than *four inches* at each end; and
 - (2) where necessary, have such storey posts, iron columns, stanchions or piers, of brick, stone or other not less suitable material, on a solid foundation sufficient to carry the superstructure.
 - (3) where any such pier is not constructed of material impervious to moisture and is in contact with the ground or concrete or other material covering the ground (not being reinforced concrete), it shall be provided with a damp-proof course.

49. A wall shall not be so constructed that a part overhangs ^{Overhang-} any part beneath it, unless the projection is properly corbelled ^{ing.} out or supported.

50. A wall or pier which is built at an angle with another ^{Bonding.} wall shall be properly bonded therewith or otherwise securely tied thereto.

51. Where a wall of a public building or a domestic building ^{Coping.} is carried up above a roof, flat or gutter, so as to form a parapet, it shall be properly coped or otherwise protected to prevent water from running down the sides of the parapet or soaking into any wall.

52. Where a wall is a party wall—

^{Additional provisions as to party walls.}

(1) it shall be carried up at least as high as the under- side of the slates or other covering of the roof;

(2) if the wall is not carried up above the underside of the slates or other covering, the slates or other covering shall where practicable be properly and solidly bedded in mortar on the top of the wall;

(3) no opening shall be made or left in the wall;

(4) the end of every wooden bressummer, beam, joist, purlin or plate, and of all bond timber, placed in the wall—

(a) shall not extend beyond the middle of the wall; and

(b) shall be properly encased in either brickwork or other solid and incombustible material, not less than *four inches* thick, or an iron beam box with a solid back;

(5) no timber or woodwork forming part of the roof of the building, except laths and slate battens properly embedded in mortar or other not less suitable incombustible material, shall extend upon or across the wall.

Stopping up
of holes in
external
walls.

53. Where a hole is made in an external wall of a building below the level of the ground immediately adjoining the wall, it shall be so stopped up as to prevent the free passage of gas into the building through the hole otherwise than by means of a pipe.

Internal
walls
supporting
floors and
roofs.

54. Every internal wall which bears or assists in bearing the load of a floor or roof shall be of sufficient strength to support the load bearing on it and shall be either—

(1) constructed of bricks or blocks properly bonded and solidly put together with mortar, or of other good hard and suitable material properly and solidly put together; or

(2) constructed with framework properly framed together.

CHIMNEYS AND FLUES.

Definition
of "flue"
and
"chimney".

55. For the purpose of the following byelaws relating to chimneys and flues, "flue" means any duct through which smoke or other products of combustion pass, and "chimney" means the material surrounding the flue.

Exceptions

56. Byelaws 57 to 78 (as to chimneys and flues) shall not apply—

(1) to any chimney shaft which is structurally independent and erected in connection with a building of the warehouse class, or to any duct or pipe in connection with the shaft if the duct or pipe is properly constructed of good, hard and incombustible material and is so arranged as to avoid the risk of fire;

(2) to any chimney which is so constructed as not to be capable of use except in connection with a fire or stove which burns gas only, or to any chimney which does not form part of the structure of a building, if the chimney is constructed of incombustible material of sufficient thickness and suitably insulated from any floor, wall or roof through which it passes, and if suitable provision is made effectually to prevent the flames of the fire or stove from coming into contact with the floor of the room in which it is situated.

57. Every chimney and chimney breast shall be constructed ^{Materials} of—

(1) bricks or blocks properly bonded and solidly put together with mortar; or

(2) other good hard and suitable incombustible material properly and solidly put together, and this requirement as to material to be used shall be deemed to be satisfied by the use of any material which complies with the test for materials for flues, furnace casings, hearths and similar purposes prescribed in British Standard Specification No. 476—1932.

58.—(1) A chimney and chimney breast which is built <sup>Founda-
tions, bond-
ing, etc.</sup> against or forms part of a wall and extends to or below the surface of the ground adjoining the wall shall—

(a) rest upon a foundation which would comply with the requirements of byelaw 22 (as to the foundations of structural walls) if the chimney were a pier forming part of the wall;

(b) have a damp-proof course if it is not constructed of material impervious to moisture;

(c) be properly bonded with or otherwise securely tied into the wall.

(2) A chimney which is built against or forms part of a wall but does not extend to the surface of the ground adjoining the wall shall—

(a) be properly bonded with or otherwise securely tied into the wall; and

(b) rest upon a metal or concrete beam, or on sufficient corbels of brick, stone or other hard and incombustible material if the work so corbelled out does not project from the wall more than the thickness of the wall measured immediately below the corbel.

59. The jambs of a fireplace opening shall be not less than ^{Jambs.} *eight-and-a-half inches* wide on each side.

Lintels, etc. 60.—(1) A sufficient arch or lintel of brick, stone or other hard and suitable incombustible material, or a sufficient bar of steel, wrought iron or other not less suitable metal, shall be built over the fireplace opening to support the chimney breast.

(2) Where the chimney breast projects more than *four-and-a-half inches* from the face of the wall, and the jamb on either side is less than *thirteen inches* wide, the abutments of any arch so built shall be tied in by a bar or bars of steel, wrought iron or other not less suitable metal, of sufficient strength, *eighteen inches* longer than the opening, turned up and down at the ends, and built into the jambs on each side.

Thickness of back of openings. 61.—(1) Where a fireplace opening is in an external wall, the back of the opening shall be not less than *four inches* thick.

(2) Where two fireplace openings are built back-to-back in a wall other than a party wall, the back common to the two openings shall be not less than *four inches* thick.

(3) The back of every other fireplace opening shall be not less than *eight-and-a-half inches* thick.

(4) The thickness required by this byelaw shall extend to a height not less than—

(a) *twelve inches* above the fireplace opening; and

(b) if the opening is in a party wall and is constructed for use in connection with a cooking range, *nine feet* above the level of the hearth.

Thickness of breasts, etc. 62. A chimney breast and the material surrounding a flue shall not be less than *four inches* thick.

Rendering of brick-work. 63. Where the face of any material surrounding a flue or fireplace opening is less than *two inches* from any timber or woodwork and the material is less than *eight-and-a-half inches* thick, the face of the material, if of bricks or blocks, shall be properly rendered, and, if of other material, shall be such as to afford adequate protection from fire to the timber or woodwork.

64. The inside of a chimney, if constructed of bricks or blocks, shall be properly rendered or pargeted as it is carried up, and, if of other materials, shall be otherwise suitably protected, except that, where any part of the chimney is lined with fireclay or stoneware not less than *three-quarters-of-an-inch* thick or other not less suitable incombustible material of sufficient thickness, such part of the chimney as is so lined need not be rendered or pargeted or otherwise protected.

Rendering
of inside of
chimneys.

65. Where the back or outside of a chimney does not form part of the outer face of an external wall and the material of which it is constructed is less than *eight-and-a-half inches* thick, the back or outside of that part of the chimney which is below the roof, flat or gutter shall be properly rendered or otherwise suitably protected.

Rendering
of outside
of
chimneys.

66. A flue shall be not less than *seven-and-a-half inches* across in every direction.

Size of
flues.

67. Where the course of a flue makes with the horizontal an angle of less than *forty-five degrees*, that part of the chimney shall be properly supported with suitable incombustible material and the upper side thereof shall be not less than *eight-and-a-half inches* thick.

Oblique
flues.

68. Where a chimney is constructed in connection with any furnace, steam boiler or close-fire, used or intended to be used for any purpose of trade, business or manufacture, or is constructed in connection with any cooking range or cooking apparatus of a building used or intended to be used as a hotel, inn or restaurant, the flue of the chimney shall be surrounded with brickwork not less than *eight-and-a-half inches* thick, or other solid and incombustible material of adequate thickness giving at least an equivalent degree of heat insulation.

Flues of
furnaces,
etc., used
for trade
purposes.

69. Where a flue is in a party wall and is not back-to-back with another flue, the material at the back of that part of the flue which is below the roof, flat or gutter shall be not less than *eight-and-a-half inches* thick.

Flues in
party walls.

70.—(1) A chimney shall be carried up all round in brickwork or other not less suitable material not less than *four inches* thick to a height not less than *three feet* above the adjoining roof, flat or gutter, measured from the highest point in the line of junction with the roof, flat or gutter.

Projection
above the
roof.

(2) Where the chimney is not constructed of material impervious to moisture and passes through a roof at a point within *two feet* of a ceiling, the chimney shall be provided with a damp-proof course immediately above the roof.

Maximum height of projection above roof.

71. A chimney, or group of chimneys bonded together, shall not be built higher above the highest point in the line of junction with the roof, flat or gutter of the building than a height equal to *six* times the least width of the chimney, or *six* times the over-all width of the group of chimneys measured horizontally at right angles to its greatest horizontal dimension, as the case may be, unless the chimney or group of chimneys is otherwise made secure.

Iron holdfasts, etc.

72. An iron holdfast or other metal fastening shall not be placed within *two inches* of a flue or fireplace opening.

Woodwork in chimneys, breasts, etc. etc.

73.—(1) Timber or woodwork shall not be placed in a wall or chimney breast within *nine inches* of a flue or fireplace opening.

(2) Where the timber or woodwork is placed in a chimney breast, there shall be a thickness of not less than *nine inches* of incombustible material between the timber or woodwork and the flue or fireplace opening, or the timber or woodwork in the chimney breast shall be otherwise suitably protected from fire.

Wooden plugs in chimneys.

74. A wooden plug shall not be driven into or built into a wall or chimney breast within *six inches* of a flue or fireplace opening.

Openings for pipes, etc.

75. No opening for the insertion of a pipe for conveying smoke or other products of combustion, or for the insertion of a ventilating valve, or for any other purpose, shall be made or left in a chimney within *nine inches* of any timber or other combustible substance.

Flues communicating with habitable rooms.

76. A flue which communicates with a room intended for human habitation shall not communicate with any other room:

Provided that a flue may communicate with a single fireplace which is common to a living room and a kitchen or scullery.

77.—(1) A hearth shall be constructed in connection with Hearths. every fireplace opening and shall —

(a) be fixed under and in front of the opening;

(b) be properly constructed of stone, slate, bricks, tiles or other incombustible material properly and securely supported;

(c) be not less than *six inches* thick;

(d) extend not less than *six inches* at each end beyond the opening;

(e) project not less than *sixteen inches* from the chimney breast;

(f) be so laid that its upper surface is not lower than the floor of the room in which the opening is situated.

(2) No combustible material shall be left in any space beneath the hearth.

78. Timber or woodwork shall not be placed under a fireplace opening within *ten inches* of the upper surface of the hearth. Woodwork under fireplace openings.

FACTORY CHIMNEY SHAFTS.

79. Byelaws 80 to 84 (as to factory chimney shafts) apply to chimney shafts which are structurally independent and erected in connection with a building of the warehouse class. Application of byelaws to certain chimney shafts.

80. A shaft and its foundation shall either—

(1) comply with byelaw 81 (as to shafts constructed of brickwork); or

(2) be designed and constructed in accordance with the following requirements:—

(a) the appropriate limits of stress for the materials of which it is constructed shall not be exceeded when the shaft is subjected to a horizontal wind pressure of—

(i) *seventeen pounds per square foot*, if the height of the shaft does not exceed *forty feet*;

(ii) *twenty-two pounds per square foot*, if the height of the shaft does not exceed *sixty feet*;

Construction of shafts and their foundations.

(iii) *twenty-six pounds per square foot*, if the height of the shaft does not exceed *eighty feet*;

(iv) *twenty-seven pounds per square foot*, if the height of the shaft does not exceed *one hundred feet*;

(v) *thirty-two pounds per square foot*, if the height of the shaft does not exceed *two hundred feet*;

(b) the shaft shall be capable of resisting, without overturning, a wind pressure of *one-and-a-half* times that specified for its height in sub - paragraph (a) of this paragraph;

(c) the base of the shaft shall rest upon solid undisturbed rock, or upon any other suitable foundation if, when the shaft is subjected to the wind pressure specified for its height in sub-paragraph (a) of this paragraph, the pressure on the ground under the foundation does not exceed the safe bearing capacity of the ground;

(d) where the foundation is a layer of plain cement concrete, the angle of dispersion of pressure through the concrete shall be not less than *forty-five degrees* with the horizontal;

(e) for the purposes of sub-paragraph (a) of this paragraph, the wind pressure shall be assumed as acting uniformly over the whole height of the shaft, the total lateral force being taken as the product of the wind pressure and the maximum vertical projected area.

Shafts constructed of brickwork.

81. A shaft constructed of brickwork shall, if it is not designed and constructed in accordance with paragraph (2) of the last preceding byelaw, comply with the following requirements:—

(1) the bricks shall be hard and well-burnt, and properly bonded and solidly put together with mortar;

(2) where the horizontal section of the shaft is circular or in the form of a regular polygon, the external diameter or least width at its base shall be not less than *one-twelfth* of its height measured from the base;

(3) where the horizontal section of the shaft is rectangular, the lesser width at its base shall be not less than *one-tenth* of its height measured from the base;

(4) the thickness of the brickwork shall be not less than *eight-and-a-half inches* at the top of the shaft and for not more than *twenty feet* below the top, and shall be increased by not less than *four inches* for each additional *twenty feet* or part of *twenty feet* of the height of the shaft measured downwards;

(5) the shaft shall have a batter of not less than *two-and-a-half inches* in every *ten feet*;

(6) the base of the shaft shall rest upon footings which shall be built in cement mortar and shall—

(a) project in every direction from the base for not less than *two-thirds* of the thickness of the brickwork of the shaft at the base;

(b) be in height not less than *one and one-third* times their projection;

(c) be either in regular offsets from the base or in one offset;

(d) be built solid to the level of the base;

(7) the footings shall rest upon—

(a) solid undisturbed rock; or

(b) a layer of cement concrete of sufficient width and thickness; or

(c) a sufficient raft of cement concrete properly constructed and where necessary suitably reinforced; or

(d) a layer of cement concrete of sufficient width and thickness on suitable piles driven to a proper depth; or

(e) some other not less sufficient substructure as a foundation;

(8) where the footings rest upon cement concrete and the bearing capacity of the ground under the concrete is not inferior to that of firm clay, coarse sand or confined sand, the requirements of sub-paragraph (b) of paragraph (7) of this byelaw shall be deemed to be satisfied if—

(a) the projection of the concrete in every direction from the base of the shaft is not less than *one-and-a-half* times the thickness of the brickwork at the base;

(b) the thickness of the concrete is not less than *one and one-third* times the projection of the concrete beyond the footings.

Protection. 82. Any structural steel or metal reinforcement in a shaft shall be adequately protected against heat and corrosion.

Openings. 83. The width of any opening formed in the side of a shaft shall not exceed *one-third* of the internal diameter of the shaft, and the sides of the opening shall be strengthened to offset any loss of strength due to the formation of the opening.

Lining. 84. Every shaft shall be provided with an independent lining which shall be—

(1) of a material which complies with the test for materials for flues, furnace casings, hearths and similar purposes prescribed in British Standard Specification No. 476—1932, and is of sufficient thickness;

(2) carried up to a sufficient height to protect the shaft from damage by heat;

(3) separated from the shaft by a cavity not less than *one inch* wide which shall be suitably covered at the top by a projection from the shaft.

FLOORS AND STAIRCASES.

Strength and stability of floors. 85. Every floor shall be so constructed as to be of adequate strength and stability.

Protection of timber on sleeper walls, etc. 86. Where any timber used in the construction of a floor rests upon a sleeper wall or is otherwise in contact with the ground or concrete or other material covering the ground, sufficient precautions shall be taken to protect the timber from dampness arising from the ground.

Solid floors. 87.—(1) Every floor of boards, planks or wood blocks laid or bedded directly upon concrete or other solid foundation resting on the ground shall be so constructed or treated as to protect the floor from dampness or dry rot.

(2) Where there is no water pressure under the floor, this requirement shall be deemed to be satisfied if—

(a) the boards, planks or wood blocks are laid or bedded upon a continuous layer, not less than *one-eighth-of-an-inch* thick, of bitumen of a suitable grade or coal tar pitch, which is carried up against the walls adjoining the floor to the level of the upper surface of the floor; and

(b) where the boards or planks are nailed to wooden fillets embedded in concrete, the fillets are thoroughly impregnated with creosote.

88. Every metal stanchion, column or post which is the sole or principal support of a floor shall be so constructed or protected as to have an adequate degree of fire-resistance. Metal stanchions, etc., supporting floors.

89. Where the floor of a room intended for human habitation and situated over a stable is constructed of boards or planks laid upon joists, a thickness of not less than *three inches* of concrete or other solid material shall be placed between the joists and be properly supported. Rooms over stables.

90. Where any part of a floor, which is situated over an enclosed space containing a furnace or baker's oven, is less than *eighteen inches* from the top of the furnace or oven, that part of the floor shall be either— Rooms over furnaces and bakers' ovens.

(1) so constructed as to have an appropriate degree of fire-resistance; or

(2) sufficiently protected on the underside by a ceiling entirely composed of incombustible material.

91. Where a room intended for human habitation is situated over a motor garage or over a shop in separate occupation— Rooms over garages and shops.

(1) the floor of the room shall be either—

(a) so constructed as to have an appropriate degree of fire-resistance, or

(b) sufficiently protected on the underside by a ceiling entirely composed of incombustible material;

(2) every wall of the staircase leading to the room, which separates the staircase from the garage or shop, shall be constructed of incombustible material;

(3) there shall be no direct communication between the staircase and the garage or shop.

- Stairs in internal staircases.** 92. The stairs in every internal staircase shall be constructed in a suitable manner, and this requirement shall be deemed to be satisfied if the stairs are constructed in the manner prescribed in British Standard Specification No. 585—1934.
- External staircases.** 93. Where, in a building not more than *two* storeys in height, the only means of access to the upper storey is by an external staircase, the staircase shall be of adequate strength and durability.
- Handrails.** 94. Every staircase shall be provided, where necessary, with a sufficient handrail or handrope which shall be properly and securely fixed.
- Tenements or flats.** 95. A building intended for separate occupation by *two* or more families shall comply with the following requirements:—
- (1) every wall forming part of a main staircase shall be so constructed as to have a suitable degree of fire-resistance;
 - (2) where the building does not comprise more than *two* storeys but exceeds *twenty-four thousand cubic feet* in capacity, every flight of stairs and landing forming part of a main staircase shall be so constructed or protected on the under side as to have a suitable degree of fire-resistance;
 - (3) where the building comprises more than *two* storeys—
 - (a) every flight of stairs and landing forming part of a main staircase shall be so constructed or protected on the under side as to have a suitable degree of fire-resistance;
 - (b) every part of every floor between two sets of rooms in separate occupation and every support to such floor shall be so constructed as to have a suitable degree of fire-resistance;
 - (c) and, in addition, where the building exceeds *twenty-four thousand cubic feet* in capacity, the floor of every lobby, corridor, passage and landing, intended to be used by the several occupiers in common, every flight of stairs forming part of a main staircase, and every support to such a flight of stairs, shall be so constructed as to have a suitable degree of fire-resistance;

(4) where—

(a) an external staircase or flight of stairs so constructed as to have a suitable degree of fire-resistance and not against or in close proximity to any window (other than a window which has a fire-resisting glazing and no part of which is capable of being opened) or other opening in an external wall of the building (other than a doorway intended solely as a means of access to the staircase or stairs with a fire-resisting door capable of being closed); or

(b) some other not less suitable means of escape additional to the ordinary means of egress from the building,

affords communication between the ground and every storey above the ground storey on which there is a set of rooms in separate occupation, the requirements of this byelaw—

(i) shall not apply if the building does not exceed *sixty thousand cubic feet* in capacity or does not comprise more than *two* storeys;

(ii) shall, if the building exceeds *sixty thousand cubic feet* in capacity and comprises more than *two* storeys, apply only as regards the main staircase of the building, and every room, lobby, corridor, passage or landing, forming the main approach to the external staircase or flight of stairs or other external means of escape;

(5) for the purpose of this byelaw, every storey of which any part is above the average level of the ground immediately adjoining the building shall be reckoned as a storey, and the capacity of the building means the aggregate of the cubical contents of all such storeys in the building.

ROOFS.

96. Every roof shall be so constructed as to be of adequate strength and stability. Strength and stability of roofs.

97.—(1) The roof of a building shall be weatherproof and, except as provided in paragraph (2) of this byelaw, shall be constructed of or externally covered with one or other of the following materials, or partly of one and partly of another:— To be weather-proof, and materials for roofs.

- (a) natural or asbestos cement slates;
- (b) tiles or slabs of burnt clay, concrete, stone, glass or asbestos cement;
- (c) lead, copper or zinc;
- (d) asphalte mastic (containing not less than *eighty-three per cent.* of mineral matter) not less than *three-quarters-of-an-inch* thick laid on boards of a finished thickness not less than *one inch* or on a base of concrete or hollow tiles;
- (e) built-up material of a total thickness of not less than *three-tenths-of-an-inch* composed of not less than *three* layers of bituminous felt laid in bituminous mastic on a base of concrete or hollow tiles;
- (f) asbestos cement sheeting, wired glass sheeting, iron or steel sheeting well galvanised and of a thickness not less than that known as No. 24 Birmingham Wire Gauge, or protected metal sheeting of a not less thickness of metal;
- (g) bituminous material laid on a base of boards, concrete or hollow blocks, and covered with a continuous layer not less than *one inch* thick of cement mortar or cement concrete, or with tiles made of clay, concrete or asbestos cement, or with not less than *one-half-of-an-inch* thickness of bitumen macadam composed of fine gravel or stone chippings with no greater percentage of bitumen than *seven per cent.*;
- (h) any other suitable slates, tiles, metal or sheeting affording at least an equal degree of fire-resistance to that of the comparable materials set out respectively in subparagraphs (a), (b), (c) and (f) above, or any other suitable combination of materials affording at least an equal degree of fire-resistance to that of the comparable combination of materials set out respectively in subparagraphs (d), (e) and (g) above.

(2) This byelaw shall not apply so as to require a roof to be constructed of or covered with fire-resisting material in the case of a domestic building which is distant not less than *twice* its height from the nearest boundary of its curtilage and from any other building.

(3) In this byelaw the expression "roof" includes any gutter or trough forming part of or attached to the roof and any turret, dormer, lantern light, skylight or other erection forming part of the roof, but does not include a door, door frame, window or window frame of a turret, dormer, lantern light, skylight or other erection.

SHORT-LIVED MATERIALS.

98. The provisions of section 53 of the Public Health Act, 1936, shall apply to the following materials as being materials which are, in the absence of special care, liable to rapid deterioration, or are otherwise unsuitable for use in the construction of permanent buildings:—

Specifica-
tion of
materials.

(1) so far as they are used wholly or principally for the construction of the weather-resisting part of a roof or external wall of a building—

(a) softwood boarding of a finished thickness less than *three-quarters-of-an-inch* (measured, in the case of weatherboarding, at its thickest part);

(b) sheets of compressed fibre or wood pulp;

(c) ply-wood;

(d) plaster board;

(e) fibrous plaster;

(f) lime or gypsum plaster on wood or metal lath;

(g) cement plaster not exceeding *one-and-a-half inches* in thickness on wood or metal lath;

(h) sheet iron or steel (whether galvanised or not) which is not painted or otherwise protected by a bituminous or other not less suitable coating;

(i) felt;

(j) canvas or cloth;

(2) so far as it is used wholly or principally for the construction of the weather-resisting part of a roof of a building—

unprotected softwood boarding not included in paragraph (1) (a) of this byelaw.

SPACE ABOUT BUILDINGS.

Space in
front of
buildings.

99.—(1) There shall be provided in front of a domestic building intended to be used wholly or partly for human habitation an open space which, measured at right angles from the building to the boundary of any land or premises immediately opposite, or in the case of a building fronting on a street to the opposite side of the street, shall throughout the whole frontage of the building extend to a distance of not less than *twenty-four feet*:

Provided that, if the building fronts on a street of a less width than *twenty-four feet*, the distance may be not less than the width of the street, together with *one-half* of the difference between that width and *twenty-four feet*.

(2) Any open space provided within the curtilage of the building in pursuance of this bylaw shall be free from any erection thereon above the level of the ground, except a fence or wall not exceeding *six feet six inches* in height, or a portico, porch, step or other like projection from the building, or a gate.

Amount
of space at
rear of
buildings.

100. There shall be provided in the rear of a domestic building intended to be used wholly or predominantly for human habitation an open space exclusively belonging thereto and of an extent not less than *one hundred and fifty square feet*.

Measure-
ment of
space at
rear of
buildings.

101.—(1) The open space required by the last preceding bylaw shall extend throughout the entire width of the building, and the distance across the open space from the line of the rearmost wall of the building and from any projection from the building to the boundary of any lands or premises immediately in the rear of the building shall be not less in any part than—

(a) *fifteen feet*, if the height of the building is not more than *twenty-five feet*;

(b) *twenty feet*, if the height of the building is more than *twenty-five feet* but is not more than *thirty-five feet*;

(c) *twenty-five feet*, if the height of the building is more than *thirty-five feet* but is not more than *fifty feet*.

(2) Where by reason of the exceptional shape of the site of the building the distance across the open space required by paragraph (1) of this byelaw cannot be obtained throughout the entire width of the building, it shall be sufficient if the mean distance across the open space is not less than the required minimum distance.

(3) If the height of the building exceeds *fifty feet*, the distance across the open space shall be such a distance as is equal to not less than *half* the height of the building, and, if in consequence of the exceptional shape of the site or of the design of the building it is not reasonably practicable to provide such open space at the rear of the building, it shall be sufficient if so much of the open space as it is not practicable to provide at the rear of the building is provided at a side of the building other than the front.

102.—(1) Where it is intended to erect a building to which the last two preceding byelaws apply on a site abutting on two or more streets, or to re-erect a building to which the last two preceding byelaws apply, and it is not reasonably practicable to comply with the requirements of those byelaws, it shall be sufficient if there is provided at the rear, or on one side of the site other than the front of the building, an open space exclusively belonging to the building of an extent—

Buildings
on sites
abutting on
two or more
streets, and
re-erected
buildings.

(a) in the case of a new building, of not less than *one hundred and fifty square feet*; or

(b) in the case of a re-erected building, of not less than that of any open space previously provided in connection with the building but in no case less than *one hundred square feet*.

(2) An open space provided in accordance with the provisions of this byelaw—

(a) shall extend throughout at least *ten feet* of the width or depth of the building for a mean distance across of not less than *ten feet*; and

(b) shall either abut on a street or be connected with a street by a passage or other similar opening so arranged as to be capable at all times of affording a free circulation of air between the open space and the street.

Measurement when lower storeys are used for trade, etc.

103. Where in a building the accommodation for human habitation is wholly above the ground floor, the open space required by byelaws 100, 101 or 102 (as to space at the rear of buildings) shall be measured at the level of the lowest floor on which the accommodation for human habitation is provided, and for the purposes of those byelaws the height of the building shall be measured from that level.

Open space to be free from erections.

104.—(1) The open space required by byelaws 100, 101 or 102 (as to space at the rear of buildings) shall be free from any erection thereon above the level of the ground, except—

(a) a watercloset, earthcloset or privy, and an ashpit; and

(b) any building or part of a building of the type described in paragraph (2) of byelaw 4 or paragraph (1) of byelaw 5, which does not exceed *eighty square feet* in area and *eight feet* in height and is not less than *ten feet* from the rearmost wall of the building in respect of which the open space is provided.

(2) The open space when measured in accordance with the last preceding byelaw shall be free above the level therein referred to from any erection, except a parapet, ventilator, lantern light or skylight, not exceeding *three feet* in mean height above that level, or a chimney stack.

Stables.

105. There shall be provided for a building intended to be used as a stable in connection with a domestic building an open space adjoining and exclusively belonging thereto of an extent of not less than *one hundred and fifty square feet* and free from any erection thereon above the level of the ground except a suitably constructed receptacle for dung.

Alterations, etc., to buildings.

106. No alteration or addition shall be made to a building and no building shall be erected that shall cause the open space provided about a building to be less than that required by these byelaws.

VENTILATION OF BUILDINGS.

Windows.

107.—(1) A sufficient number of windows shall be constructed in the wall of every storey of a domestic building in such a manner and in such a position that each of the windows affords effectual means of ventilation by direct communication with the external air.

(2) Every habitable room shall be provided with a window or windows which shall open directly into the external air and—

(a) have a total area, exclusive of the main framework, of not less than *one-tenth* of the floor area of the room; and

(b) be so constructed that a total area, exclusive of the main framework, of not less than *one-twentieth* of the floor area of the room may be opened, and so that at least to the extent of this requirement the windows can be opened at the top.

(3) Paragraph (2) of this byelaw shall not apply to any room used or adapted to be used for the lawful detention of any person.

(4) For the purposes of this byelaw, a window which opens to an enclosed veranda, conservatory or similar place, which itself has a window or windows satisfying this byelaw, shall be deemed to communicate directly with the external air.

108.—(1) No window in a habitable room required in pursu-
 ance of the last preceding byelaw shall be constructed so as to
 open to a court enclosed on every side unless the distance
 across the court, measured from the window to the opposite
 wall of the court, is equal at least to *two-thirds* the height
 measured from the level of the top of the window to the level of
 the eaves or top of the parapet of the opposite wall.

Windows
 opening
 to courts,
 etc.

(2) No such window shall be constructed so as to open to a court which is open on one side, and of which the length measured from the open side exceeds *twice* the width, unless the window opens to the court on the side opposite to the open end, or unless the distance across the court, measured from the window to the opposite wall of the court, is equal at least to *half* the height measured from the level of the top of the window to the level of the eaves or top of the parapet of the opposite wall.

(3) Where the side of a domestic building abuts upon the boundary of its curtilage and a part of the building projects at the rear at a right-angle to the building, any space between the boundary and the projection shall, for the purposes of paragraph (2) of this byelaw, be deemed to be a court which

is open on one side and where there is no wall on that boundary opposite to the projection, the height of the eaves or parapet of the projection shall be measured in calculating the distance across the court.

Ventilation
of lowest
floors.

109. The floor of the lowest storey of a domestic building, if it is a boarded floor and is not a solid floor composed of boards, planks or wood blocks laid or bedded directly upon concrete or other similar dry and impervious foundation, shall be so constructed that there shall be, between the underside of every joist on which the floor boards are laid and the upper surface of the ground or of the asphalt, concrete or other material with which the ground surface or site of the building is covered, a clear space of not less than *three inches* in every part if the ground is covered with asphalt, concrete or other material, and of not less than *nine inches* in every part if the ground is not so covered, and such space shall be thoroughly ventilated by means of suitable and sufficient air-bricks or by some other effectual method:

Provided that, if a floor is constructed partly as a solid floor and partly as a boarded floor, the part of the floor which is boarded shall, if it is not otherwise thoroughly ventilated, be ventilated by an air channel through the concrete or other foundation of the solid floor.

Ventilation
of habitable
rooms with-
out flues.

110. Every habitable room of a building which is without a fireplace opening shall, in addition to any ventilation afforded by a window or a door, be provided with a sufficient fan-light opening to a ventilated lobby or corridor, or with some other aperture or air-shaft having an unobstructed sectional area of not less than *thirty square inches* and opening directly to the external air.

Ventilation
of bath-
rooms and
lavatories.

111. Every bathroom or lavatory in a building shall be provided with adequate means of ventilation.

Ventilation
of larders.

112. Every pantry or larder provided in a domestic building (other than a dwelling-house to which section 85 of the Hendon Urban District Council Act, 1929 applies) for the storage of perishable food shall either be ventilated to the external air by an opening fitted with a fly-proof cover so constructed as to allow an adequate flow of air, or be provided with mechanical means of ventilation.

113. In the case of a building intended for separate occupation by more than *two* families, every part of a staircase intended for common use, which is above the ground storey and not open to the external air, shall be adequately ventilated.

Ventilation of staircases in buildings divided into tenements.

114. Every public building shall be provided with adequate means of ventilation.

Ventilation of public buildings.

DIMENSIONS OF ROOMS.

115. Every room intended for human habitation in a building shall comply with the following requirements:—

Height of rooms.

(1) if the room is not a room wholly or partly in the roof of the building, it shall in every part except beneath an uncovered beam or joist be *eight feet* at the least in height;

(2) if the room is a room wholly or partly in the roof of the building, it shall be *eight feet* at the least in height over not less than *one-half* of the area of the room, measured at a height of *five feet* above the floor level of the room.

PART III—WORKS AND FITTINGS.

*DRAINAGE.

116. The lowest or the only storey of a building (other than so much of a storey as comprises a cellar or other chamber intended for storage only, and constructed in a dry soil or so as to be impervious to water) shall be at such a level or so constructed as to allow the construction of a drain or drains sufficient for the effectual drainage of that storey.

Level of lowest storey.

117. The roof of a building (whether flat or not) shall be so constructed as effectually to drain to suitable and sufficient gutters, shoots or troughs, which shall be provided for receiving and conveying all water which may fall on the roof and shall be connected with a sufficient number of suitable down-pipes constructed so as to carry away all such water without causing dampness in any part of any wall or foundation of the building or any adjacent building:

Drainage of roofs.

* In administering these byelaws the Council will, where a byelaw does not specify a particular method for satisfying its requirements, normally accept any methods recommended in the appropriate Specification issued by the Institute of Plumbers.

Provided that this byelaw shall not apply to any building the roof of which is covered with thatch or other similar material, if other proper and sufficient arrangements are made to prevent any water which may fall on the roof from causing dampness in any part of any such wall or foundation.

Materials
and con-
struction
of drains.

118. Every drain (other than a subsoil drain or a drain for the conveyance solely of trade effluent) constructed in connection with a building shall comply with such of the following requirements as are applicable:—

(1) it shall be constructed of good sound pipes of suitable material, and this requirement shall be deemed to be satisfied if new glazed ware pipes conforming to either British Standard Specification No. 65—1937 or No. 540—1937, or new cast iron pipes conforming to British Standard Specification No. 437—1933, or new concrete pipes conforming to British Standard Specification No. 556—1934, are used;

(2) it shall be properly supported and protected against injury, laid at a proper inclination, and provided with suitable watertight joints;

(3) it shall, as far as practicable, be laid in a straight line or in a series of straight lines, and shall at every change of direction be formed with suitably curved pipes;

(4) it shall be capable of withstanding a reasonable hydraulic test, smoke or air test under pressure, or other suitable test;

(5) it shall be of adequate size, and if intended for the conveyance of foul water shall have an internal diameter of not less than *four inches*;

(6) where it passes through a building it shall to that extent be constructed of cast iron or other not less suitable metal;

(7) where it is laid on or in the ground—

(a) if it is constructed of material other than cast iron or other metal of not less strength, it shall, so far as it lies within a distance of *fifty feet* from the building, be laid on a bed of concrete unless the nature of the soil renders this unnecessary;

(b) if it is constructed of corrosible material, it shall be suitably protected inside and outside against corrosion;

(8) no part of the drain shall be laid under any building where any other mode of construction is practicable;

(9) where a part of the drain is laid under a building, that part shall—

(a) be laid in a straight line for the whole extent beneath the building or, if this is impracticable, in a series of straight lines;

(b) if laid in the ground and constructed of material other than cast iron or other metal of not less strength, be completely surrounded with concrete not less than *six inches* thick;

(c) be provided with adequate means of access for its whole length and, if not laid in one straight line, be provided at each change of direction with an inspection chamber, the cover of which shall be airtight if the drain is not itself fitted with an airtight access door;

(10) every inlet to the drain, other than an inlet provided for the ventilation of the drain, shall be properly trapped;

(11) if the drain is intended for the conveyance of foul water, it shall be provided with adequate means of access for the purpose of cleansing.

119. Every drain and private sewer intended solely for the conveyance of trade effluent shall be constructed of good sound pipes of suitable material, and shall be properly supported and protected against injury, laid at a proper inclination, and provided with suitable watertight joints.

Drains and private sewers for trade effluents.

120. Where the distance of any part of a drain trench from the foundation of a wall of a building is less than *three feet*, and the depth of that part of the trench below the level of the bottom of the foundation is more than *two-thirds* of that distance, that part of the trench shall be filled up with concrete to a level the depth of which beneath the level of the bottom of the foundation shall not exceed *two-thirds* of that distance.

Drain trenches.

Drains
passing
through or
under walls.

121. Where a drain passes through or immediately under a wall, a sufficient arch shall be turned over the drain, or some other not less suitable support for the wall shall be provided so as effectually to prevent the wall from damaging the drain by settlement or otherwise.

Branch
drains.

122. Every branch drain or tributary drain shall join any other drain obliquely in the direction of the flow of that drain.

Inlets
within
buildings.

123. No inlet to a drain, other than a drain for the conveyance solely of trade effluent, shall be made within a building, except—

- (1) a trapped gully fitted with a suitable cover;
- (2) an inlet which is a necessary part of the connection of any watercloset, bath, sink, urinal, bidet or lavatory basin;
- (3) a junction with another drain.

Ventilating
pipes to be
provided for
foul water
drains.

124. The drains intended for conveying foul water from a building shall be provided with at least *one* ventilating pipe, situated as near as practicable to the building and as far as practicable from the point at which the drain empties into the sewer or other means of disposal:

Provided that a soil pipe from a watercloset, or a waste pipe from a slop sink, constructed in accordance with these byelaws may serve for the ventilating pipe of the drain, if its situation is in accordance with this byelaw.

Construc-
tion of soil
pipes, etc.

125. The soil pipe from a watercloset, and the waste pipe from a slop sink, other than parts of such pipes carried up as ventilating pipes, shall be—

(1) formed of suitable material, and this requirement shall be deemed to be satisfied if new cast iron pipes conforming to British Standard Specification No. 416—1935 for heavy grade pipes, or new lead pipes conforming to either British Standard Specification No. 602—1939 or No. 603—1935, are used;

(2) of an internal diameter not less than that of any pipe connecting it with the watercloset or slop sink, and in any case not less than *three inches*.

126. A ventilating pipe to a drain, and the part of a soil pipe from a watercloset or of a waste pipe from a slop sink which is carried up as a ventilating pipe, shall—

Construction of ventilating pipes.

(1) be formed of suitable material to secure adequate durability, and this requirement shall be deemed to be satisfied if new cast iron pipes conforming to British Standard Specification No. 416—1935 for medium grade pipes, or new lead pipes conforming to either British Standard Specification No. 602—1939 or No. 603—1935, are used;

(2) be not less than *three inches* in internal diameter;

(3) be carried upwards to such a height and in such a manner as effectually to prevent the escape of foul air from the drains into any building;

(4) be covered at its open end, as a protection against obstruction, with a wire cage of copper or galvanised iron or other not less suitable cover admitting the free passage of air.

127. A ventilating pipe to a drain, a soil pipe from a watercloset, and a waste pipe from a slop sink, shall be capable of withstanding after erection a reasonable smoke or air test under pressure, and shall not—

Other requirements for ventilating pipes, soil pipes and waste pipes from slop sinks.

(1) have a trap at its point of junction with the drain, or (except where necessary as part of the apparatus of any watercloset or slop sink) in any other part of the pipe;

(2) have any bend or angle, except where unavoidable in which case the bend or angle shall—

(a) be as obtuse as possible;

(b) not reduce the internal diameter of the pipe;

(c) where necessary be provided with a suitable access door;

(3) except in so far as it passes through any cornice or similar external architectural feature, or being a ventilating pipe is carried immediately beneath the covering of the roof, be enclosed by any part of the building, unless—

(a) it is formed of material satisfying the requirements of byelaw 125 (as to the construction of soil pipes); and

(b) if formed of lead or other material similarly susceptible to external injury, it is exposed throughout so much of its length as is enclosed by any part of the building (except where it passes through a floor or ceiling) or is adequately protected by enclosure in a chase with a metal or metal lined front.

Waste pipes
from baths,
etc.

128. A waste pipe from a bath, sink (not being a slop sink), bidet or lavatory basin, and a pipe for carrying off dirty water, shall—

(1) discharge so as not to cause dampness in a wall or foundation of a building;

(2) if it discharges to a drain otherwise than by a soil pipe from a watercloset or a waste pipe from a slop sink, be disconnected from the drain by a trapped gully with a suitable grating above the level of the water in the trap;

(3) if it is more than *six feet* in length, be provided with a suitable trap;

(4) if it discharges into a soil pipe from a watercloset or a waste pipe from a slop sink, be provided whatever its length with a suitable trap adequately secured against destruction of the water seal.

Overflow
pipes.

129. An overflow pipe from a water cistern shall discharge in an exposed and conspicuous position, and so as not to cause dampness in any part of a building.

Private
sewers.

130. A private sewer (not being a sewer for the sewerage of a new street or a sewer for the conveyance solely of trade effluent) shall comply with the following requirements:—

(1) the provisions of byelaw 118 (as to the materials and construction of drains) shall apply to the sewer with the following modifications:—

(a) paragraph (5) shall apply as if "*six inches*" were substituted for "*four inches*" in the last line;

(b) in place of paragraph (7) there shall be substituted the following requirements:—

(7) (a) where it is constructed of material other than cast iron or other metal of not less strength and it is laid in the ground at a depth less than *four feet* or more than *fourteen feet*, it shall, so far as it lies within a distance of *fifty feet* from a building, be laid on a bed of concrete not less than *four inches* thick and haunched with concrete to not lower than the horizontal diameter of the sewer;

(b) where such a sewer or part of such a sewer is not less than *four feet* and not more than *fourteen feet* below the surface of the ground, it shall for that distance be similarly laid on and haunched with concrete, if the nature of the soil renders this necessary;

(c) where the sewer is constructed of corrosible material and is laid on or in the ground, it shall be suitably protected inside and outside against corrosion;

(c) paragraphs (3), (10) and (11) shall not apply;

(2) the sewer shall, unless it exceeds *thirty inches* in diameter, be laid in a straight line or in a series of straight lines;

(3) a manhole shall be provided at every point at which the sewer changes either its direction or gradient, except where the sewer exceeds *thirty inches* in diameter in which case manholes shall be provided at intervals not exceeding *three hundred feet*;

(4) a manhole shall be of such size as to allow access to the sewer for rodding and shall be constructed of brickwork or concrete in such a manner as to exclude all subsoil water, the brickwork or concrete being carried up to ground level and provided with a proper iron cover;

(5) all inverts to manholes shall be formed with proper channels and benching;

(6) a manhole which is more than *five feet* in depth, measured from the level of the top of the cover to the invert, shall be provided with a sufficient number of step-irons.

Communi-
cations
between
drains and
sewers and
between
sewers.

131.—(1) (a) A connection between a drain and a private or public sewer shall be so made that the drain shall join the sewer obliquely in the direction of the flow of the sewer;

(b) if practicable the connection shall be made at an existing junction in the sewer;

(c) where a junction is made in a sewer, the sewer shall be properly rejointed and made watertight;

(2) (a) if a connection between a private sewer and a public sewer or between two private sewers is not made at a manhole, a manhole shall be made upon the private sewer within *forty feet* of the public sewer or other private sewer to which it is connected;

(b) every such manhole shall comply with the requirements as to manholes set out in the byelaw relating to private sewers.

WATERCLOSETS.

132. A watercloset constructed in connection with a building shall comply with the following requirements:—

Recep-
tacles.

(1) the pan, basin or other receptacle (hereafter in this byelaw called "the pan") shall be of non-absorbent material so constructed and fitted as to receive and contain sufficient water and to allow any filth to fall free of the sides directly into the water;

Flushing
apparatus.

(2) the flushing apparatus shall be such as to secure the prompt and effectual flushing and cleansing of the pan;

Communi-
cation with
supply
pipes, etc.

(3) no part of the watercloset apparatus, other than the flushing apparatus, shall be directly connected with a supply or distributing pipe;

Containers.

(4) no container or similar fitting shall be fixed under the pan;

"D" Traps.

(5) no trap of the kind known as a "D" trap shall be fixed in connection with the watercloset;

Ventilation
of traps.

(6) where the watercloset discharges into a soil pipe which also receives the discharge from another watercloset, or from a bath, sink, urinal, bidet or lavatory basin, the trap of the watercloset shall be ventilated by a pipe which shall—

(a) have an internal diameter of not less than *two inches*;

(b) be connected with the arm of the soil pipe at a point not less than *three* and not more than *twelve inches* from the highest part of the trap, on that side of the water-seal which is nearer to the soil pipe;

(c) either have an open end as high as the top of the soil pipe or be carried into a soil pipe at a point not less than *three feet* above the highest connection to the soil pipe;

(7) where the watercloset is in connection with a domestic building and is entered directly from the external air, it shall be provided with a sufficient opening for lighting and ventilation as near the top as practicable and communicating directly with the external air; Lighting and ventilation of external water-closets.

(8) where the watercloset is in a domestic building and is not entered directly from the external air, it shall either— Lighting and ventilation of internal water-closets.

(a) have an external wall for at least *one* of its sides and a window of an area of not less than *two square feet*, exclusive of the frame, opening directly into the external air; or

(b) be sufficiently ventilated by mechanical means and sufficiently lighted;

(9) where the watercloset is in a domestic building— Separation of certain water-closets.

(a) it shall not communicate directly with a room intended principally for human habitation (other than a bedroom, dressing-room or bathroom) or for the manufacture, preparation or storage of food for human consumption;

(b) Any wall of the watercloset which separates it from such a room shall be constructed of suitable material and shall extend from the floor to its roof or ceiling;

(c) it shall, if it communicates with a bedroom or dressing-room and there is not another watercloset in the building which does not so communicate, be so constructed that it can be entered otherwise than through the bedroom or dressing-room;

Definition.

(10) for the purpose of this byelaw the expression "watercloset" shall include any room which is partitioned or divided into two or more cubicles, each containing a pan, if the partitions or divisions are so constructed as to allow the free circulation of air throughout the room.

URINALS.

133. A urinal connected with a building which has a supply of water laid on shall comply with the following requirements:—

Receptacles.

(1) the urinal shall be provided with a basin, stall, trough or other suitable receptacle or receptacles of non-absorbent material;

Grating on outlets.

(2) the outlet from the receptacle or receptacles shall be provided with an efficient grating;

Flushing apparatus.

(3) the urinal shall be provided with suitable apparatus for effectually flushing and cleansing the receptacles provided;

Communication with supply pipes, etc.

(4) no part of the urinal apparatus, other than the flushing apparatus, shall be directly connected with a supply or distributing pipe;

Ventilation of traps.

(5) if the urinal can be entered from within the building, and is constructed to discharge into a soil pipe which also receives the discharge from another urinal, or from a watercloset, bath, sink, bidet or lavatory basin, the trap of the urinal shall be ventilated by a pipe which shall—

(a) be of an internal diameter not less than that of the trap or *two inches*, whichever is less;

(b) be connected with the waste pipe from the urinal at a point not less than *three* and not more than *twelve inches* from the highest part of the trap, on that side of the water seal which is nearer to the soil pipe; and

(c) either have an open end as high as the top of the soil pipe or be carried into a soil pipe at a point not less than *three feet* above the highest connection to the soil pipe.

(6) if the urinal can be entered from within the building—

(a) it shall be provided with sufficient means of lighting and ventilation; Lighting and ventilation.

(b) the floor shall be constructed of or covered with impermeable material; Floors.

(7) if the urinal is in a domestic building—

(a) it shall not communicate directly with a room intended principally for human habitation (other than a bedroom, dressing-room or bathroom) or for the manufacture, preparation or storage of food for human consumption; Separation of certain urinals.

(b) any wall of the urinal which separates it from such a room shall be constructed of suitable material and shall extend from the floor to its roof or ceiling.

EARTHCLOSETS.

134. An earthcloset constructed in connection with a building shall comply with the following requirements:—

(1) its only direct entrance shall be from the external air; Entrance.

(2) it shall be not less than *forty feet* from any well, spring or stream of water, used or likely to be used by man for drinking or domestic purposes, or for the manufacture or preparation of articles of food or drink for human consumption, or for the cleansing of vessels with a view to the preparation or sale of such articles, and otherwise in such a position as not to render any such water liable to pollution; Position.

(3) it shall be provided with a sufficient opening for lighting and ventilation as near the top as practicable and communicating directly with the external air; Lighting and ventilation.

(4) the floor shall be of non-absorbent material which shall in every part, including the part beneath the seat, be not less than *three inches* above the surface of the adjoining ground and have a fall or inclination towards the entrance door of not less than *one-half of an inch to the foot*; Floors.

Construction of receptacles.

(5) the receptacle for faecal matter (hereafter in this byelaw called "the receptacle") shall be of non-absorbent material so constructed and placed that its contents shall not escape by leakage or otherwise or be exposed to rainfall or to the drainage of any waste water or liquid refuse;

Size of receptacle.

(6) the receptacle shall be of a capacity not exceeding *two cubic feet* (or such less capacity as may be sufficient to contain all faecal matter, earth or other material, which may accumulate therein during a period of not more than *one week*);

Not to communicate with any drain.

(7) no part thereof or the receptacle therein shall communicate with any drain;

(8) it shall be provided with—

Provision of vessels for deodorising material.

(a) a suitable vessel of adequate capacity for dry earth or other suitable deodorising material so constructed and placed as to admit of ready access for depositing therein the necessary supply of the earth or other material; and

(b) sufficient means for applying the earth or other material to the faecal matter in the receptacle;

Walls.

(9) the containing walls of the space beneath the seat, except such opening as may be necessary for affording access to the space, shall be impervious to moisture;

Seats and spaces for receptacles.

(10) the seat, the aperture in the seat, and the space beneath the seat, shall be of such dimensions that the receptacle can be so placed and fitted beneath the seat as to prevent the deposit of faecal matter elsewhere than in the receptacle;

Access to spaces for receptacles.

(11) adequate access for cleansing the space beneath the seat and for removing therefrom or placing and fitting therein the receptacle shall be provided by means of the adjustment of or removal of the seat or by some other suitable means.

CESSPOOLS, ETC.

Cesspools and sewage tanks.

135. A cesspool constructed in connection with a building (other than a tank intended for the reception or disposal of trade effluent) shall comply with the following requirements:—

(1) it shall be—

Position.

(a) not less than *fifty feet* from any dwelling-house, or public building, or any building in which any person is employed in any manufacture, trade or business;

(b) not less than *sixty feet* from any well, spring or stream of water, used or likely to be used by man for drinking or domestic purposes, or for the manufacture or preparation of articles of food or drink for human consumption, or for the cleansing of vessels with a view to the preparation or sale of such articles, and otherwise in such a position as not to render any such water liable to pollution;

(2) it shall be so constructed and situated that there shall be ready means of access for cleansing it and for removing its contents without carrying them through any dwelling-house, or public building, or any building in which any person is employed in any manufacture, trade or business;

Access for
cleansing.

(3) it shall be so constructed as not to discharge any foul matter or foul water into a sewer or watercourse;

Discharge.

(4) it shall be so constructed as to be impervious to liquid either from the outside or the inside, and if constructed of brickwork shall be rendered inside with cement and sand in suitable proportions or properly asphalted, and if constructed in a soil liable to be water-logged shall be backed with not less than *nine inches* of well-puddled clay;

Construc-
tion.

(5) a cesspool (not being a settlement tank or other tank for the reception or disposal of foul matter) shall be arched or otherwise properly covered and adequately ventilated;

Covering
and venti-
lation of
cesspools.

(6) a tank, if covered, shall be either adequately ventilated or provided with adequate mechanical means for drawing off gases.

Ventilation
of tanks.

136. A tank intended for the reception or disposal of trade effluent shall be so constructed and placed as not to cause pollution to any well, spring or stream of water, used or likely to be used by man for drinking or domestic purposes, or for

Tanks for
trade
effluents.

the manufacture or preparation of articles of food or drink for human consumption, or for the cleansing of vessels with a view to the preparation or sale of such articles.

WELLS.

137. A well constructed in connection with a building and intended to supply water for human consumption shall comply with the following requirements:—

Position.

(1) it shall be—

(a) not less than *thirty feet* from any ashpit;(b) not less than *forty feet* from any earthcloset or privy;(c) not less than *sixty feet* from any cesspool;

Paving of adjoining ground.

(2) the ground adjoining the well shall for a distance of not less than *four feet* in every direction be covered with a watertight paving constructed so as to slope away from the well;

Construction of sides.

(3) the sides of the well shall be rendered impervious for a depth of not less than *six feet* from the level of the adjoining ground;

Access for cleansing.

(4) a dug well shall be so constructed as to be readily accessible for cleansing;

Curbing of dug wells.

(5) the top of a dug well shall be surrounded by a curb extending not less than *six inches* above the level of the paving referred to in paragraph (2) of this byelaw and so constructed as to prevent any surface water gaining access to the well;

Lining of bored wells.

(6) the lining tubes of a bored well shall project not less than *six inches* above the level of the paving referred to in paragraph (2) of this byelaw, and such projection shall be surrounded on the outer side with concrete not less than *six inches* thick for its full height;

Covering, etc., of bucket wells.

(7) a well from which water is drawn by a bucket shall be provided with—

(a) an efficient hinged wooden or iron cover which will close the well when not in use; and

(b) a stand for the bucket not less than *six inches* above the level of the paving referred to in paragraph (2) of this byelaw;

(8) a well from which water is drawn by a pump shall be provided with a cover so fitted as to prevent surface water or other matter from gaining access to the well. Covering of pump wells.

WATER TANKS AND CISTERNS.

138. A tank or cistern constructed or fitted in connection with a building and intended to be used for the storage of rainwater for human consumption shall comply with the following requirements:—

(1) if the tank or cistern forms the sole supply of water for domestic purposes, it shall have a minimum working capacity of not less than *one thousand five hundred gallons*, but such capacity may be divided into two or more units; Capacity.

(2) it shall be provided with an overflow pipe so placed or fitted as not to allow animals to enter through it; Overflow pipes.

(3) any draw-off tap or the end of any suction pipe shall be not less than *three inches* from the bottom of the tank or cistern; Draw-off apparatus.

(4) if the tank or cistern is wholly above the adjoining ground, it shall be provided with a solid and close fitting cover so constructed and fitted as to exclude all polluting matter; Covering.

(5) if the tank or cistern is either wholly or partly below the level of the adjoining ground— Construction, etc., of tanks and cisterns below ground.

(a) its walls, floor and roof shall be constructed of brick, concrete or other suitable material, and if constructed of a material which is not impervious to water shall be properly lined with an impervious material; and

(b) all pipes connected to it shall be so connected by proper and water tight joints;

Covered
tanks and
cisterns.

(6) a tank or cistern provided with a fixed cover shall—

(a) have a manhole fitted with a proper iron cover and of sufficient size to allow the tank or cistern to be entered and cleansed; and

(b) be provided with a sufficient ventilator or ventilators the open end of which shall be fitted with a cover of copper wire gauze.

STOVES AND OTHER FITTINGS.

Floors
under
detached
stoves,
etc.

139. Where a stove, oven, copper, steam boiler or other similar apparatus (not being apparatus in which the heat is supplied by gas or electricity) is fitted in a building elsewhere than on a hearth constructed in connection with a fireplace opening in accordance with byelaw 77 (as to hearths), the floor under the apparatus and for a distance of *sixteen inches* beyond its front and *six inches* beyond its back and sides shall be constructed of incombustible material of sufficient thickness or protected by a sufficient slab or plate of incombustible material:

Provided that, in the case of a domestic anthracite stove used solely for directly heating the room, hall or passage in which it is placed, the distance for which the floor in front of the stove is required to be so constructed or protected shall be *nine inches*.

Fixing of
certain
stoves and
ranges.

140. Where a stove or range (other than a stove or range of the self-setting or independent type) is fixed in a fireplace opening, any space between the back of the opening and the stove or range shall be filled with incombustible material.

Flue pipes
for gas
fires.

141. Every room of a building, in which a gas fire or other similar apparatus for heating the room is fitted, shall be provided with an adequate flue pipe connected with such gas fire or apparatus properly fitted and not communicating with any other room, and discharging either—

(1) into a chimney not communicating with any other room; or

(2) directly into the external air in a suitable position, in which case the flue pipe shall be fitted with a suitable terminal or outside windguard.

142.—(1) Where a geyser or similar gas - heated water apparatus of the rapid water-heating type is fitted in a room, an adequate flue pipe shall be constructed in connection therewith and shall—

Flue pipes
for geysers,
etc.

(a) be properly and securely fixed and of a diameter not less than that of the flue spigot at the top of the geyser or other apparatus;

(b) be fitted with a suitably constructed baffle;

(c) discharge either into a chimney not communicating with any other room, or directly into the external air in which case the flue pipe shall be fitted with a suitable terminal or outside windguard, or, where neither of the foregoing methods is reasonably practicable, into a space immediately below the roof which does not form part of any room and is itself freely ventilated to the external air.

(2) No such apparatus shall be fitted in a room which is without a window capable of being opened.

PART IV—MISCELLANEOUS.

GIVING OF NOTICES, ETC.

143.—(1) A person who intends to erect a building to which the foregoing byelaws relate shall give to the Council notice in writing of his intention, and shall send or deliver the notice to the Clerk or Surveyor of the Council with written particulars, so far as this may be necessary to show whether the building complies with any of the foregoing byelaws or any conditions of exemption which apply to it, of—

Notice of
intention to
build.

(a) the class or nature of the building and whether it will be used wholly or in any part as a dwelling-house;

(b) the materials of which the building will be constructed;

(c) the mode of drainage;

(d) the means of water supply.

(2) He shall also send or deliver to the Clerk or Surveyor the following plans and sections, drawn in ink or reproduced in a clear and intelligible manner on suitable and durable material:—

Delivery of
plans, etc.

(a) a plan of every floor, and sections of every storey, floor and roof of the building (not being a floor, storey or roof not governed by or material for the purposes of any of the foregoing byelaws or any conditions of exemption which apply to the building);

(b) a block plan of the building;

(c) a key plan showing the position of the site when it is not sufficiently identifiable from the block plan.

Scale of plans, etc.

(3) The plans and sections shall be to a scale of not less than *one inch* to every *eight feet* or, if the building is so extensive as to render a smaller scale necessary, not less than *one inch* to every *sixteen feet*; and the block plan shall be to a scale not less than *one inch* to every *forty-four feet*.

Contents of plans, etc.

(4) There shall be shown, so far as may be necessary to show whether the building complies with any of the foregoing byelaws or any conditions of exemption which apply to it—

(a) upon the plans and sections—

(i) the level of the site of the building, the level of the lowest floor of the building, and the level of any street adjoining the curtilage of the building, in relation to one another and above some known datum;

(ii) the position, form and dimensions of the foundations, walls, floors, roofs, chimneys and the several parts of the building;

(iii) the form and dimensions of every watercloset, urinal, earthcloset, cesspool, well and water tank or cistern to be constructed in connection with the building;

(b) upon the block plan—

(i) the size and position of the building and of the appurtenances of the properties immediately adjoining the building;

(ii) the position and width of every street adjoining the curtilage of the building;

(iii) the size and position of every yard and open space belonging to the building;

(iv) the position of every watercloset, urinal, earthcloset, ashpit, cesspool, well and water tank or cistern in connection with the building;

(v) the lines of drainage of the building, the size, depth and inclination of every drain, and the means to be provided for the ventilation of the drains;

(vi) the position and level of the outfall of the drains;

(vii) where the drainage is intended to be connected to a sewer, the position of the sewer.

(5) In addition to the foregoing requirements of this byelaw, a person who intends to construct a wall or part of a wall in accordance with byelaw 28 (as to walls with a structural framework of steel, iron or reinforced concrete), or byelaw 29 (as to walls of cement concrete or reinforced concrete), or to design and construct a wall or part of a wall in accordance with sub-paragraph (b) of paragraph (2) of byelaw 36 (as to the thickness of walls of brickwork or masonry), or to design and construct a chimney shaft in accordance with paragraph (2) of byelaw 80 (as to the construction of shafts and their foundations) shall when required by the Clerk or Surveyor, send, or deliver to him such of the following information as is necessary to show whether the wall or the part of the wall or the chimney shaft complies with any of the foregoing byelaws which apply to it:—

Additional information in respect of certain walls and chimney shafts.

(a) a specification of the materials proposed to be used;

(b) the proportions of the materials in any concrete or mortar;

(c) drawings showing the details of construction and, in particular, of any framework, and the sizes and position of any reinforcing metal;

(d) calculations of strength.

(6) A person who intends to make a material change within the meaning of section 62 of the Public Health Act, 1936, in the purposes for which a building or part of a building is used, shall send or deliver notice of such change to the Clerk or Surveyor, whether or not it is proposed to execute any work in connection with the change.

Notice of material change of user.

Notice and
plans of
works of
drainage.

144. A person who intends to execute works of drainage in connection with a building shall give to the Council notice of his intention, and shall send or deliver the notice to the Clerk or Surveyor of the Council with a description in writing of the works, and shall, so far as may be necessary to show whether the works comply with the byelaws relating to such works, send or deliver to the Clerk or Surveyor plans as required by the last preceding byelaw showing—

(1) the lines of the proposed drainage, the size, depth and inclination of each new drain, and the means to be provided for the ventilation of the drains;

(2) the position and level of the outfall of the drains;

(3) where the drainage is intended to be connected to a sewer, the position of the sewer.

Plans, etc.,
to be
deposited
in
duplicate.

145. A person required by the last two preceding byelaws to deposit plans or other documents shall deposit them in duplicate.

Notice of
commence-
ment of
work, etc.

146. A person who intends to erect any building, or otherwise execute any work or instal fittings to which any of the foregoing byelaws apply—

(1) shall give to the Surveyor of the Council not less than *twenty-four hours'* notice in writing—

(a) of the date and time at which the erection of the building, or the execution of such work or matter as aforesaid, will be commenced; and

(b) before the covering up of any drain, private sewer, concrete or other material laid over the site, foundation or damp-proof course or the construction of any hearth, involved by the erection of the building or the execution of the work;

Opening up
work.

(2) if he neglects or refuses to give any such notice, shall comply with a notice in writing by the surveyor requiring him within a reasonable time to cut into, lay open or pull down so much of the building or work as prevents the surveyor from ascertaining whether any of the foregoing byelaws have been contravened;

(3) shall permit the surveyor to take such samples of the materials to be used in the construction of the building, or the execution of such work or matter as aforesaid, as may be necessary to enable him to ascertain whether such materials comply with these byelaws;

Taking of samples.

(4) if he has received a notice in writing from the surveyor pointing out the respects in which the building or work contravenes these byelaws, and as a result of such notice shall have amended or added to the building or work so as to secure compliance with these byelaws, shall within a reasonable time after the completion of such work give notice in writing to the surveyor of its completion;

Notice of completion of work required by surveyor.

(5) shall give to the surveyor notice in writing—

Notice of completion of building and of proposal to occupy.

(a) of the erection of the building or of the execution of the work within a reasonable time after its completion; and

(b) in the case of a building, not less than *seven days* before it is occupied, of the proposal to occupy.

147.—(1) A person who is required by the foregoing byelaws to give, send or deliver any notice or any plans, sections or written particulars shall sign such notice, plans, sections or written particulars or cause them to be signed by his duly authorised agent.

Signature and delivery of notices, etc.

(2) If such notice or other document is signed by an agent, it shall state the name and address of the person on whose behalf it has been given, sent or delivered.

(3) Any such notice or other document shall be sent or delivered either to the office of the council or to the office of the person to whom the notice is required by the foregoing byelaws to be sent or delivered.

PENALTIES.

148. Every person who shall offend against any of the foregoing byelaws shall be liable on summary conviction to a fine not exceeding *five pounds*, and in the case of a continuing offence to a further fine not exceeding *forty shillings* for each day during which the offence continues after conviction therefor.

PRESCRIBED PERIOD.

149. For the purposes of Part II of the Public Health Act, 1936, the prescribed period in relation to the passing or rejection of plans shall, in the case of plans deposited less than *three clear days* before a meeting of the council, be *five weeks*.

REPEAL OF BYELAWS.

150.—(1) The Byelaws described in the Table in this byelaw, so far as they are in force in the district, and except in so far as they relate to new streets, are hereby repealed.

Description of byelaws.	Date of making.	By whom made.	Date of Confirmation.	By whom confirmed.
New streets and buildings	11th December 1926	Urban District Council of Finchley	31st December, 1926	Minister of Health
New buildings and certain matters in connection with buildings	31st January, 1929	Rural District Council of Hendon	15th April, 1929	
New streets and buildings	28th November, 1927	Urban District Council of Hendon	12th January, 1928	

(2) This repeal shall not apply as regards any work begun before the date of operation of this byelaw, or any work not so begun if before that date the plans shall either have been passed by the council or the prescribed period for their rejection shall have expired.

(3) The exceptions from repeal contained in the last preceding paragraph shall not prohibit any such work from being executed in accordance with or so as not to contravene the foregoing byelaws.

SCHEDULES.

FIRST SCHEDULE.

1.—*Dead Loading.*

For the purpose of calculating the dead loading of a building or any part of a building, the weights of the materials shall be assumed to be those set out in British Standard Specification No. 648—1935 (Schedule of Unit Weights of Building Materials), or if not set out in that Specification shall be determined by test.

2.—*Superimposed Loading.*

For the purpose of calculating the superimposed loading on beams, pillars, piers and walls, the minimum superimposed load on each floor and on the roof of a building shall be estimated as equivalent to the dead load specified in the following table for the appropriate type of building, floor or roof:—

Type No.	Description of building, floor or roof.	Pounds per square foot of floor area.
1	Rooms of dwelling-houses, flats, hotel buildings and similar residential buildings; hospital rooms and wards; corridors, staircases and landings of dwelling-houses and flats.	40
2	Offices—floors above entrance floor.	50
3	Offices—entrance floor and floors below entrance floor.	80
4	Churches, schools, reading rooms, art galleries and similar building	70
5	Retail shops and garages for cars of not more than two tons dead weight.	80
6	Assembly halls; drill halls; dance halls; gymnasias; light workshops; public spaces in hotels and hospitals; corridors, staircases and landings for the buildings mentioned in this table other than those described in Type No. 1 above; cinemas; restaurants and grand stands.	100
7	Warehouses, book stores, stationery stores and buildings similarly used, and garages for motor vehicles exceeding two tons dead weight. Actual load to be calculated but not less than	200
8	Flat roofs and roofs inclined at an angle with the horizontal of not more than twenty degrees.	30 (per square foot of covered area).
9	Roofs inclined at an angle with the horizontal of more than twenty degrees.	10 (per square foot of covered area).

(a) For the purpose of calculating the total load to be carried on pillars, piers and walls of buildings of more than *two storeys* in height, the superimposed loads for the roof and topmost storey shall be calculated in full in accordance with the schedule of loading set out above, but for the lower storeys a reduction of superimposed loads may be allowed as under:—

Reduction of Superimposed Loads on Pillars, Piers and Walls

For the first storey below the topmost storey—10 per cent. reduction of its superimposed load.

For the second storey below the topmost storey—20 per cent. reduction of its superimposed load.

For the third storey below the topmost storey—30 per cent. reduction of its superimposed load.

For the fourth storey below the topmost storey—40 per cent. reduction of its superimposed load.

For the fifth storey and each lower storey below the topmost storey—50 per cent. reduction of its superimposed load.

These reductions may be made by estimating the proportion of floor area carried by each pillar, pier or wall. No such reduction shall be allowed on any floor scheduled for an applied superimposed load exceeding *one hundred pounds per square foot*.

(b) Except as hereinafter provided, the wind pressure on a building shall be assumed to be not less than *fifteen pounds per square foot* in any horizontal direction on the upper two-thirds of the vertical projection of the surface of the building, with an additional pressure of not less than *ten pounds per square foot* on all projections above the general roof level:

Provided that, where the height of a building is less than *twice its width*, and where the building is stiffened by walls and floors, the wind pressure may be neglected.

(c) A superimposed load which may roll or move on wheels shall be calculated as being equivalent to a static loading which exceeds the weight of the rolling or moving load by not less than *fifty per cent*.

3.—Partitions.

Where the position of a partition in a building is definitely located in the design, the actual weight of the partition shall be included in the dead floor load.

Where the position of a partition is not definitely located in the design, a uniformly distributed load sufficient to allow for it shall be added to the dead floor load, and for all such floors used for offices the minimum total allowance for partitions shall be at the rate of *twenty pounds per square foot* of floor area.

SECOND SCHEDULE.

In determining the maximum permissible pressures on walls constructed of bricks or blocks, the crushing strength of the individual brick or block shall be determined in the following manner:—

Twelve whole bricks or blocks with sides not less than *three inches* long shall be taken. The materials shall be soaked for *twenty-four hours* in water at a temperature between *fifteen degrees* and *twenty degrees* Centigrade. The frogs in bricks shall then be filled with mortar and the top and bottom surfaces of hollow bricks or blocks shall be made plane and parallel with mortar. The mortar shall consist of *one part* (by weight) of cement and *three parts* (by weight) of dry and clean Leighton pit sand, the cement used being either normal Portland cement or rapid-hardening Portland cement. After the application of the mortar to the bricks or blocks, the specimens shall be covered with damp cloths for *six hours*, then immersed in water at a temperature between *fifteen degrees* and

twenty degrees Centigrade for twenty-seven days in the case of normal Portland cement mortar, and for six days in the case of rapid-hardening Portland cement mortar, or for such period, being not less than two days, at which the mean crushing strength of three cubes each with sides three inches long made from the batch of mortar used in the preparation of the bricks or blocks and stored under similar conditions will be between two thousand and four thousand pounds per square inch.

The test pieces shall finally be crushed between three-ply wood sheets one-eighth-of-an-inch thick, the load being applied at a uniform rate of approximately two thousand pounds per square inch per minute. The average value of the crushing stress thus obtained for the twelve test pieces, calculated over the gross area of the test pieces, shall be taken as the crushing strength of the individual brick or block for the purposes of Tables 1 and 3 of this Schedule.

TABLE 1.

Permissible Pressures on Walls constructed of bricks or solid blocks and having a slenderness ratio not exceeding 6.

Column A shows the pressures allowed where the combined dead loading and superimposed loading can be assumed to be uniformly distributed over the area sustaining the load.

Column B shows the pressures allowed (subject to the average pressure not exceeding that in Column A) where the loading is a combination of the uniform pressure in Column A with increases in pressures due to eccentric loading and lateral forces.

Column C shows the pressures allowed at girder bearings, stanchion bases or other similar places where there are concentrated loads, taking into account the pressures in Columns A and B.

Crushing strength of the individual brick or block in pounds per square inch.	Mortar proportioned by volume not weaker than	Maximum permissible pressures in tons per square foot of overall area of the wall.		
		A.	B.	C.
Not less than 1,500	Lime mortar or black mortar	4	6	6
	1 : 3 : 12 cement-lime mortar	5.5	8.25	8.25
	1 : 1 : 6 cement-lime mortar	7	10.5	10.5
	Hydraulic lime mortar	5.5	8.25	8.25
	Cement mortar	8	12	12
Not less than 3,000	Lime mortar or black mortar	4	6	6
	1 : 3 : 12 cement-lime mortar	7	10.5	10.5
	1 : 1 : 6 cement-lime mortar	10	15	15
	Hydraulic lime mortar	7	10.5	10.5
	Cement mortar	11	16.5	16.5
Not less than 4,000	Lime mortar or black mortar	4	6	6
	1 : 3 : 12 cement-lime mortar	8	12	12
	1 : 1 : 6 cement-lime mortar	10	15	15
	Hydraulic lime mortar	8	12	12
	Cement mortar	13.5	20.25	20.25
Not less than 5,000	Cement mortar	16	24	24
	Cement mortar	23	34.5	34.5
Not less than 7,500	Cement mortar	30	40	45
Not less than 10,000	Cement mortar	30	40	45

Permissible pressures on masonry in which units of intermediate strength are used may be obtained by interpolation.

Crushing strength of the individual brick or block in pounds per square inch.	Mortar proportioned by volume not weaker than	Maximum permissible pressures in tons per square foot of overall area of the wall.		
		A.	B.	C.
Exceeding 10,000	1 : 2 Cement mortar.....	$\frac{X}{500} + 10$ but not exceeding 40 where X is result of test defined in this Schedule	40	48

TABLE 2.

Percentage Reduction of Permissible Pressures for slenderness ratios exceeding 6 but not exceeding 12.

Value of slenderness ratio.	Reduction of maximum permissible pressures in Table 1.
Over 6 but not more than 8	20 per cent.
Over 8 but not more than 10	40 per cent.
Over 10 but not more than 12	60 per cent.

TABLE 3.

Permissible Pressures on walls constructed of hollow blocks in cement mortar or mortar not weaker than 1 : 1 : 6 cement-lime-mortar.

Crushing strength of the individual brick or block in pounds per square inch.	Maximum permissible pressures in tons per square foot of overall area of the wall.
Not less than 500	2.0
Not less than 1,000	4.25
Not less than 2,000	8.5

The Corporate Seal of the Mayor,
Aldermen and Burgesses of the
Borough of Hendon was here-
unto affixed this
day of June, 1939, pursuant to a
resolution of the Council passed
on the nineteenth day of June,
1939.

Mayor.

Town Clerk.

APPENDIX.

The following tables give the sizes of members for timber floors for residential buildings and of roof members for timber roofs of all classes of buildings and are such as would be accepted as complying with Byelaw 17.

TABLE No. 1

COMMON RAFTERS

Clear Spans for various scantlings at different centres.
Redwood, Yellow Deal, etc. Non-graded.

Scantling in inches	Maximum CLEAR spans with rafters at following CENTRES			
	15 inches	17 inches	20 inches	25 inches
3 × 2	5' 9"	5' 6"	5' 3"	4' 9"
3½ × 2	6' 8½"	6' 5"	6' 1½"	5' 6½"
4 × 2	7' 8"	7' 4"	7' 0"	6' 4"
4½ × 2	8' 7½"	8' 3"	7' 10½"	7' 1½"
5 × 2	9' 7"	9' 2"	8' 9"	7' 11"
6 × 2	11' 6"	11' 0"	10' 6"	9' 6"

EXPLANATION.—This Table presents in an exceptionally simple and practical manner three important matters which architects and builders want to know. They are (1) size of rafters, (2) clear spans between purlins, and between purlins and wall plates or ridges and (3) centres of rafters.

Examples.—4" × 2" rafters are desired to be used. At 17" centres they may have a clear span of 7' 4". The clear distance between purlins, etc., is 9' 2"; what is the minimum size of rafters and centres to use? By simple searching it will be found that 5" × 2" rafters at 17" centres are just suitable.

TABLE No. 2

VALLEY AND HIP RAFTERS AND RIDGES

Scantlings.

Recommended by Timber Development Association.
Redwood, Yellow Deal, etc. Non-graded.

VALLEY RAFTERS.

- (a) Make $1\frac{1}{2}$ " thick and twice depth of common or jack rafter where the valley rafter is supported intermediately by purlins, which latter are strutted under junction with valley rafter, or
- (b) Make 2" thick and same depth as specified for ridges and hip rafters where the valley rafter is intermediately supported as (a).

NOTE.—Valley rafters are beams subject to considerable loads and adequate strength is essential.

HIP RAFTERS AND RIDGES.

Scantlings to be as follows :—

Depth of Rafters	Roof pitch up to about	
	35 degrees	45 degrees
3"	6" × 1 $\frac{1}{4}$ "	6" × 1 $\frac{1}{2}$ "
3 $\frac{1}{2}$ "	6" × 1 $\frac{1}{2}$ "	7" × 1 $\frac{1}{2}$ "
4"	7" × 1 $\frac{1}{2}$ "	8" × 1 $\frac{1}{2}$ "
4 $\frac{1}{2}$ "	8" × 1 $\frac{1}{2}$ "	9" × 1 $\frac{1}{2}$ "
5"	8" × 1 $\frac{1}{2}$ "	9" × 1 $\frac{1}{2}$ "
6"	9" × 1 $\frac{1}{2}$ "	11" × 1 $\frac{1}{2}$ "
7"	11" × 1 $\frac{1}{2}$ "	11" × 1 $\frac{1}{2}$ "

EXPLANATION.—The sizes of valley and hip rafters and ridges are very simply determined after the sizes of common rafters are settled.

TABLE No. 3

PURLINS. Scantlings in inches for various Clear Spans and Clear Distances apart.
Redwood, Yellow Deal, etc. Non-graded.

Span in Clear in feet.	Distance apart of Purlins in feet in Clear.													
	2	2½	3	3½	4	4½	5	6	7	8	9	10	11	12
4	3 × 2	3 × 2	3½ × 2	3½ × 2	4 × 2	4 × 2	4 × 2	4½ × 2	5 × 2	6 × 2 4½ × 3	4½ × 3	5 × 3	5 × 3	6 × 3
5	3½ × 2	3½ × 2	4 × 2	4½ × 2	5 × 2	5 × 2	5 × 2	6 × 2 5 × 3	6 × 2 5 × 3	6 × 3	6 × 3	6 × 3	6 × 3	7 × 3 6 × 4
6	4 × 2	4½ × 2	5 × 2	6 × 2	6 × 2 4½ × 3	6 × 2	6 × 3	6 × 3	6 × 3	7 × 3	7 × 3 6 × 4	8 × 3 6 × 4	8 × 3 7 × 4	8 × 3 7 × 4
7	5 × 2	5 × 2	6 × 2 5 × 3	6 × 2 5 × 3	6 × 3	6 × 3	6 × 3	7 × 3 6 × 4	7 × 3 6 × 4	8 × 3	8 × 3 7 × 4	9 × 3 7 × 4	9 × 3 8 × 4	8 × 4
8	6 × 2	6 × 2 5 × 3	6 × 3	6 × 3	6 × 3	7 × 3 6 × 4	7 × 3 6 × 4	8 × 3 7 × 4	8 × 3 7 × 4	9 × 3	9 × 3 8 × 4	8 × 4	9 × 4	9 × 4
9	6 × 2	6 × 3	6 × 3	7 × 3	7 × 3 6 × 4	8 × 3 7 × 4	8 × 3 7 × 4	9 × 3 8 × 4	9 × 3 8 × 4	9 × 4	9 × 4	9 × 4	11 × 3 9 × 5	11 × 4 9 × 5
10	6 × 3	6 × 3	7 × 3 6 × 4	8 × 3 6 × 4	8 × 3 7 × 4	8 × 3	9 × 3 8 × 4	8 × 4	9 × 4	11 × 3 8 × 5	11 × 3 9 × 5	11 × 4 9 × 6	11 × 4 9 × 6	11 × 4
11	7 × 3	7 × 3 6 × 4	8 × 3	8 × 3 7 × 4	9 × 3 8 × 4	9 × 3 8 × 4	8 × 4	9 × 4	11 × 3 9 × 5	11 × 4 9 × 5	11 × 4 9 × 6	11 × 4		
12	7 × 3	8 × 3 7 × 4	8 × 3 7 × 4	9 × 3 8 × 4	9 × 3 8 × 4	11 × 3 9 × 4	11 × 3 9 × 4	11 × 4 9 × 5	11 × 4 9 × 5	9 × 6				
13	8 × 3 7 × 4	8 × 3	9 × 3 8 × 4	8 × 4	9 × 4	11 × 3 9 × 5	11 × 4 9 × 5	11 × 4 9 × 6						
14	8 × 3	9 × 3 8 × 4	8 × 4	11 × 3 9 × 4	11 × 3 9 × 5	11 × 4 9 × 5	11 × 4 9 × 6							

EXPLANATION.—As a general rule Purlins should be placed at a distance apart in the clear to suit the most economical sized rafters. Further, Struts should be used at a reasonable distance apart so as to reduce the span of Purlins and thereby effect economy. With common rafters having a clear span of 7' 0" the distance apart of Purlins in the clear will be 7' 0". If the Purlins are strutted 6' 0" apart it will be found by the Table that 6" × 3" Purlins are suitable, and if they are strutted 10' 0" apart then 9" × 4" Purlins are necessary.

TABLE No. 4

STRUTS. Scantlings in inches for various areas of Roofs and for various lengths of Struts.
Redwood, Yellow Deal, etc. Non-graded.

Area in Feet of Roof supported by Strut = length of Rafter between Purlins by distance apart of Struts.	Length in feet of Struts having ordinary well-fixed ends.									
	4	5	6	7	8	9	10	11	12	
25	2 × 2	3 × 3	3 × 3	3 × 3	3 × 3½	3 × 3½	3½ × 4	4 × 4	4 × 4	
30	2 × 2½	3 × 3	3 × 3	3 × 3	3 × 3½	3 × 4	3½ × 4	4 × 4	4 × 4	
35	2 × 3	3 × 3	3 × 3	3 × 3	3 × 3½	3½ × 4	3½ × 4	4 × 4	4 × 4	
40	3 × 3	3 × 3	3 × 3	3 × 3½	3½ × 4	3½ × 4	3½ × 4	4 × 4	4 × 4	
45	3 × 3	3 × 3	3 × 3	3 × 3½	3½ × 4	3½ × 4	4 × 4	4 × 4	4 × 4½	
50	3 × 3	3 × 3	3 × 3	3 × 4	3½ × 4	3½ × 4	4 × 4	4 × 4½	4 × 5	
55	3 × 3	3 × 3	3 × 3½	3½ × 4	3½ × 4	4 × 4	4 × 4	4 × 4½	4½ × 5	
60	3 × 3	3 × 3	3 × 3½	3½ × 4	3½ × 4	4 × 4	4 × 4	4 × 5	4½ × 5	
65	3 × 3	3 × 3	3 × 4	3½ × 4	3½ × 4	4 × 4	4 × 4½	4 × 5	4½ × 5	
70	3 × 3	3 × 3½	3 × 4	3½ × 4	4 × 4	4 × 4	4 × 4½	4½ × 5	4½ × 5	
75	3 × 3	3 × 3½	3½ × 4	3½ × 4	4 × 4	4 × 4	4 × 5	5 × 5	5 × 5	
80	3 × 3	3 × 4	3½ × 4	3½ × 4	4 × 4	4 × 4½	4½ × 5	5 × 5	5 × 5	
85	3 × 3	3 × 4	4 × 4	4 × 4	4 × 4	4 × 4½	4½ × 5	5 × 5	5 × 5	
90	3 × 3½	3 × 4	4 × 4	4 × 4	4 × 4	4 × 5	4½ × 5	5 × 5	5 × 5	
95	3 × 3½	3 × 4	4 × 4	4 × 4	4 × 4½	4 × 5	4½ × 5	5 × 5	5 × 5	
100	3 × 3½	3½ × 4	4 × 4	4 × 4	4 × 4½	4½ × 5	5 × 5	5 × 5	5 × 5	
105	3 × 4	3½ × 4	4 × 4	4 × 4	4 × 5	4½ × 5	5 × 5	5 × 5	5 × 6	
110	3 × 4	3½ × 4	4 × 4	4 × 4	4 × 5	4½ × 5	5 × 5	5 × 5	5 × 6	

NOTES.—Under no circumstances must any Scantling dimension be REDUCED, but they may be increased to suit stock sizes. Many of the odd sizes can be cut from stock Scantlings.

EXPLANATORY EXAMPLE.—The distance centre to centre of Purlins is 7' 6" and the distance apart of Struts, centre to centre, is 6' 0". The area of roof supported by the Strut is 45 square feet. The length of Strut is 9' 0". The Strut must be 3½" × 4".

Most economical sized rafter
by effect economy. We
purlins are strutted 6' 0"
× 4" Purlins are necessary

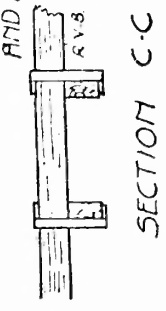
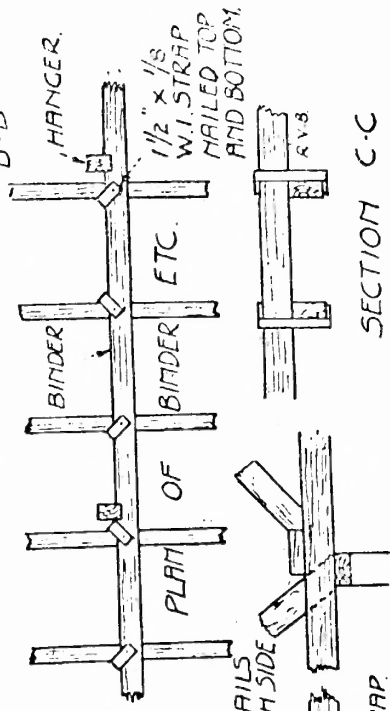
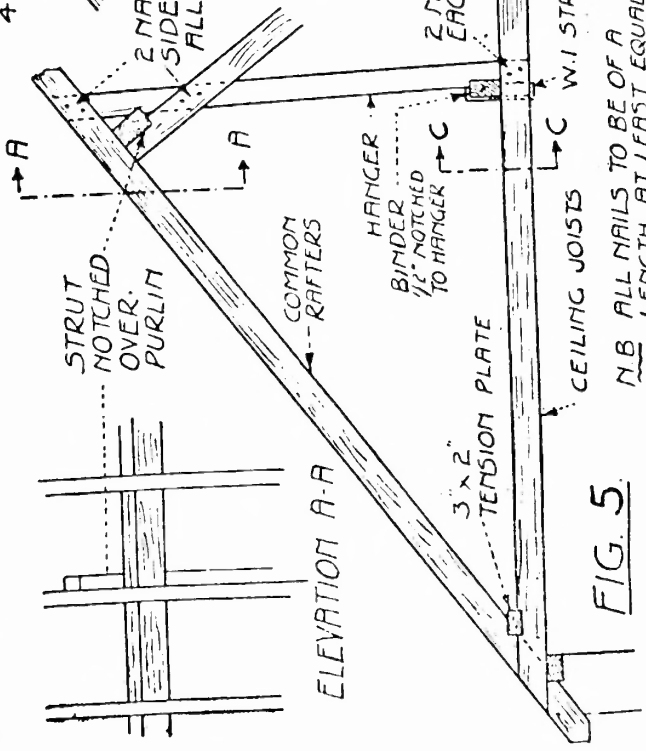
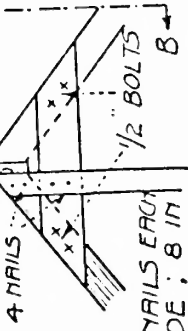
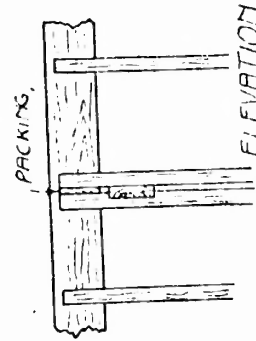
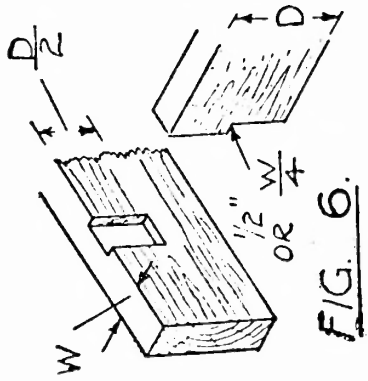
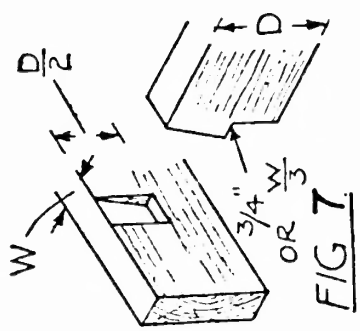
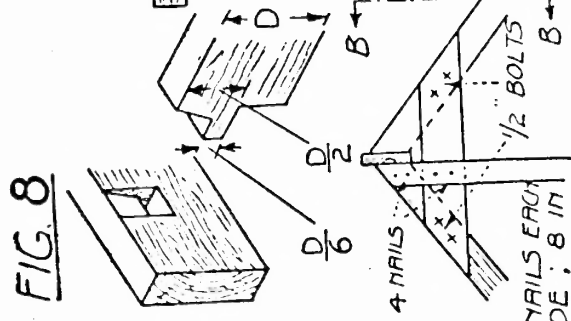
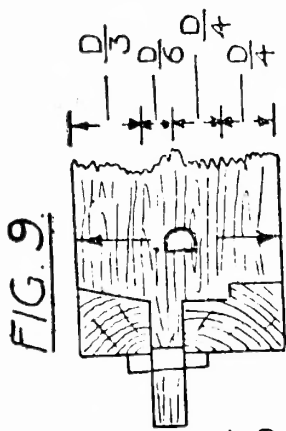

BEARINGS FOR FEET OF STRUTS

N.B. ALL NAILS TO BE OF A LENGTH AT LEAST EQUAL TO TWICE THICKNESS OF THINNER CONNECTED MEMBER, AND WHEN DRIVEN FROM FACE OF THICKER, MUST PENETRATE ENTIRELY THROUGH THINNER.

JOINTS IN TIMBER FLOORS AND FRAMING AND JOINTS IN COMMON ROOFS

TABLE No. 5

CEILING JOISTS

Clear Spans for various Scantlings at different Centres.
Redwood, Yellow Deal, etc. Non-graded.

Scantling in inches	Maximum CLEAR Spans with Ceiling Joists at following CENTRES				
	13 inches	15 inches	17 inches	20 inches	25 inches
3 × 2	6' 0"	5' 9"	5' 6"	5' 3"	4' 9"
3½ × 2	7' 0"	6' 8½"	6' 5"	6' 1½"	5' 6½"
4 × 2	8' 0"	7' 8"	7' 4"	7' 0"	6' 4"
4½ × 2	9' 0"	8' 7½"	8' 3"	7' 10½"	7' 1½"
5 × 2	10' 0"	9' 7"	9' 2"	8' 9"	7' 11"
6 × 2	12' 0"	11' 6"	11' 0"	10' 6"	9' 6"
7 × 2	14' 0"	13' 5"	12' 10"	12' 3"	11' 1"
8 × 2	16' 0"	15' 4"	14' 8"	14' 0"	12' 8"
9 × 2	18' 0"	17' 3"	16' 6"	15' 9"	14' 3"

The following are recommendations of Timber Development Association and should meet all requirements of the by-laws.

REDUCING THE SPANS BY USE OF BINDERS AND HANGERS.

A considerable saving in timber may be effected by using binders at the centre of the ordinary spans of the ceiling joists. As an instance: If the span from wall to wall is 14' 0" and no binder is used, 7" × 2" ceiling joists are necessary. If a binder (which acts as a beam) is placed at the centre of the joists, the span of the latter will be reduced to 7' 0" and 3½" × 2" ceiling joists may be used.

It is essential that binders be of adequate size and be secured properly to the joists, and that the binders be supported by hangers which are secured properly at their lower ends to the binders and at their top ends to ridge or purlins.

SIZE OF BINDERS.

With span from wall to wall of ceiling joists of up to 10' use 4" × 2" binders.
Over 10' and up to 14' use 5" × 2" binders.
Over 14' and up to 18' use 4½" × 3" binders.
Over 18' and up to 22' use 5" × 3" binders.

DISTANCE APART AND SIZES OF HANGERS.

The above sizes of binders have been computed with HANGERS 4' APART CENTRE TO CENTRE. The sizes of hangers should be 2" × 3" for ceiling joists up to about 14' span from wall to wall, and 2" × 4" for greater spans.

DIAGRAM.

FIG. 5 shows effective connection of binders to ceiling joists and hangers to binders, and hangers to ridge, etc.

CEILING JOISTS
 W.I. SIKHY
 N.B. ALL NAILS TO BE OF A LENGTH AT LEAST EQUAL TO TWICE THICKNESS OF THINNER CONNECTED MEMBER AND WHEN DRIVEN PROMPTLY ON EITHER SIDE OF JOIST.
 JOISTS IN TIMBER FLOORS AND FRAMING AND JOISTS BEARINGS FOR FEET OF STRUTS

FIG. 5

CEILING JOISTS.

Avoidance of additional loads on purlins that may be caused by ceiling hangers. Additional loads on struts (Table No. 4) caused by ceiling hangers.

HANGERS should be so arranged that they do not induce additional stresses in the purlins, and the simple way to avoid this is to fix each hanger immediately, or as near as possible, over the struts. The hangers by reason of their supporting the ceiling, which has a super-load of 25 lbs. per super foot to conform with L.C.C. by-laws, must add to the load on struts, and a very simple rule to cover this is:—

Add to the area as first column of Table 4, the area of ceiling that is supported by the hanger, and allow size of strut accordingly.

The super-load of 25 lbs. per super foot plus dead weight of ceiling joists and ceiling covering is about the same as the 15 lbs. super-load plus dead weight of materials in the roof; consequently compliance with the above rule does not provide an excessive but a practical load on the struts.

The support of hangers from the ridge may be considered to induce no stresses which the rafters are incapable of resisting safely. In fact, the hangers assist in triangulating the framework of the roof and tend to keep in equilibrium the upward thrust of the rafters; the wide hanger-support acts as a gusset plate and binds the whole of the rafters, rafters, and hanger together.

HANGERS AT MORE THAN 4' APART. If it is required to place hangers at, say, 5' or 6' apart which will allow struts to be at similar distances apart, then conform to the following rules:—

Span of ceiling joists from wall to wall.	Size of binders, the distance apart of hangers being	Size of hangers, their distance apart being
Up to 10'	5 feet.	5 feet.
Over 10' and up to 14'	5" × 2"	6 feet.
Over 14' and up to 18'	6" × 3"	Use 4" × 3"
Over 18' and up to 22'	6" × 3"	for all spans of ceiling joists.
	6" × 3"	

For all bolted connections use $\frac{1}{2}$ " dia. bolts.

Make all notches $\frac{1}{4}$ " deep instead of $\frac{1}{2}$ " as shewn by Fig. 5.

All hangers must extend to underside of ceiling joists to provide sufficient timber to resist shearing along the grain. Wherever practicable bolt hanger to strut as well as to rafter.

Always nail connections as well as bolting them.

N.B.—The above instructions only apply to cases where the hangers are more than 4' apart.

EXPLANATION.—It is now no longer possible to use, in the London area, 4" × 2" ceiling joists of such spans as 12' or 14', even with a binder, if it is merely nailed to the ceiling joists. Something much more scientific is required to avoid sagging and cracked ceilings. Unless ceiling joists are adequately suspended from the roof with proper members having proper joints, it is necessary to use ceiling joists of nearly the same size as floor joists.

The first part of the Table shows in a simple and practical manner scantlings, spans and centres which allow a wide range of choice with stock scantlings. The remainder of Table is self explanatory with the aid of Fig. 5.

It may be considered that it will be more economical to use full-sized ceiling joists than to adopt the method of suspension. The method of suspension causes a considerable saving in timber, about half; the binder is less costly than herring bone or solid strutting which is advisable for deep ceiling joists; the W.I straps cost only a few pence each and their fixing is almost negligible; and the bolts and notching cost but little.

TABLE No. 6
FLAT ROOF JOISTS

Clear Spans for various Scantlings at different Centres.
Redwood, Yellow Deal, etc. Non-graded.

Scantling in inches.	Maximum CLEAR Spans with Flat Roof Joists at following CENTRES.				
	14 inches	16 inches	18 inches	21 inches	24 inches
3 × 2	4' 3"	4' 0"	3' 9"	3' 6"	3' 3"
3½ × 2	4' 11½"	4' 8"	4' 4½"	4' 1"	3' 9½"
4 × 2	5' 8"	5' 4"	5' 0"	4' 8"	4' 4"
4½ × 2	6' 4½"	6' 0"	5' 7½"	5' 3"	4' 10½"
5 × 2	7' 1"	6' 8"	6' 3"	5' 10"	5' 5"
6 × 2	8' 6"	8' 0"	7' 6"	7' 0"	6' 6"
7 × 2	9' 11"	9' 4"	8' 9"	8' 2"	7' 7"
8 × 2	11' 4"	10' 8"	10' 0"	9' 4"	8' 8"
9 × 2	12' 9"	12' 0"	11' 3"	10' 6"	9' 9"
11 × 2	15' 7"	14' 8"	13' 9"	12' 10"	11' 11"
	15 inches	17½ inches	20 inches	22½ inches	26 inches
6 × 2½	9' 0"	8' 6"	8' 0"	7' 6"	7' 0"
7 × 2½	10' 6"	9' 11"	9' 4"	8' 9"	8' 2"
8 × 2½	12' 0"	11' 4"	10' 8"	10' 0"	9' 4"
9 × 2½	13' 6"	12' 9"	12' 0"	11' 3"	10' 6"
11 × 2½	16' 6"	15' 7"	14' 8"	13' 9"	12' 10"
	15 inches	16½ inches	18 inches	21 inches	24 inches
6 × 3	10' 0"	9' 6"	9' 0"	8' 6"	8' 0"
7 × 3	11' 8"	11' 1"	10' 6"	9' 11"	9' 4"
8 × 3	13' 4"	12' 8"	12' 0"	11' 4"	10' 8"
9 × 3	15' 0"	14' 3"	13' 6"	12' 9"	12' 0"
11 × 3	18' 4"	17' 5"	16' 6"	15' 7"	14' 8"

EXPLANATION.—This Table gives a wide range of choice of stock sized Scantlings, Spans and distances apart of Joists.

Examples.—Flat roof joists are required to span 12' between walls or beams. Search under the maximum clear span columns for 12' or not less. It will be found that 9" × 2" joists at 16" centres, or 9" × 2½" at 20" centres, or 8" × 3" at 18" centres may be used. It is particularly required to use 8" × 2" joists at 16" centres. What distance apart must beams be placed? The answer is 10' 8".

TABLE No. 7

**BEAMS FOR FLAT ROOFS AND ROOFS
NOT EXCEEDING 20 DEGREES PITCH.**

Scantlings in inches for various Spans and distances apart of Beams.
Redwood, Yellow Deal, etc. Non-graded.

Span in Clear in feet	Distance apart of Beams in feet in Clear.						
	4	5	6	7	8	9	10
6	6 × 3	7 × 3	8 × 3	8 × 3	8 × 3	9 × 3	8 × 4
7	7 × 3	8 × 3	9 × 3 8 × 4	9 × 4 8 × 4	9 × 4	9 × 4	9 × 5 11 × 4
8	8 × 3	8 × 4	8 × 4	9 × 4	9 × 5 11 × 3	9 × 5 11 × 4	9 × 6 11 × 4
9	9 × 3 8 × 4	9 × 4	9 × 4	9 × 5 11 × 4	9 × 6 11 × 4	9 × 6 11 × 4	9 × 7
10	8 × 5 11 × 3	9 × 5 11 × 3	9 × 6 11 × 4	9 × 7 11 × 4	11 × 5	11 × 5	11 × 6
11	11 × 3	11 × 4	11 × 4	11 × 5	11 × 6	11 × 6	11 × 7
12	11 × 4	11 × 5	11 × 6	11 × 7	11 × 8	11 × 8	
13	11 × 5	11 × 6	11 × 7	11 × 8			
14	11 × 5	11 × 6	11 × 8				
15	11 × 6	11 × 7	11 × 8				
16	11 × 7	11 × 8					

NOTE.—The large sized beams may be composed of 2 members well spiked or bolted together, as an instance, 11" × 6" may be of 2/11" × 3", and 11" × 7" of 11" × 4" and 11" × 3".

EXPLANATION.—This Table gives the size of beams that are required to reduce the spans of flat roof joists.

TABLE No. 8

FLOOR JOISTS TO RESIDENTIAL FLOORS

Clear spans for various Scantlings at different Centres.
Redwood, Yellow Deal, etc. Non-graded.

Scantlings in inches	Maximum CLEAR Spans with Joists at following CENTRES.				
	14 inches	15 inches	17 inches	20 inches	22 inches
3 × 2	5' 0"	4' 9"	4' 6"	4' 3"	4' 0"
3½ × 2	5' 10"	5' 6½"	5' 3"	4' 11½"	4' 8"
4 × 2	6' 8"	6' 4"	6' 0"	5' 8"	5' 4"
4½ × 2	7' 6"	7' 1½"	6' 9"	6' 4½"	6' 0"
5 × 2	8' 4"	7' 11"	7' 6"	7' 1"	6' 8"
6 × 2	10' 0"	9' 6"	9' 0"	8' 6"	8' 0"
7 × 2	11' 8"	11' 1"	10' 6"	9' 11"	9' 4"
8 × 2	13' 4"	12' 8"	12' 0"	11' 4"	10' 8"
9 × 2	15' 0"	14' 3"	13' 6"	12' 9"	12' 0"
11 × 2	18' 4"	17' 5"	16' 6"	15' 7"	14' 8"
		15 inches	17½ inches	21 inches	25 inches
6 × 2½		10' 6"	10' 0"	9' 0"	8' 6"
7 × 2½		12' 3"	11' 8"	10' 6"	9' 11"
8 × 2½		14' 0"	13' 4"	12' 0"	11' 4"
9 × 2½		15' 9"	15' 0"	13' 6"	12' 9"
11 × 2½		19' 3"	18' 4"	16' 6"	15' 7"
		15 inches	18 inches	21 inches	22½ inches
6 × 3		11' 0"	10' 6"	10' 0"	9' 6"
7 × 3		12' 10"	12' 3"	11' 8"	11' 1"
8 × 3		14' 8"	14' 0"	13' 4"	12' 8"
9 × 3		16' 6"	15' 9"	15' 0"	14' 3"
11 × 3		20' 2"	19' 3"	18' 4"	17' 5"

ADDENDA TO TABLE No. 8

It is important to understand that the above "FLOOR JOISTS TO RESIDENTIAL FLOORS" refer only to the Floors of ROOMS and not to those in CORRIDORS, STAIRS AND LANDINGS which must be in accordance with the following Table.

FLOOR JOISTS TO CORRIDORS, STAIRS AND LANDINGS

Scantlings in inches	Maximum CLEAR Spans with Joists at following CENTRES.				
	14 inches	16 inches	19 inches	22 inches	27 inches
3 × 2	3' 6"	3' 3"	3' 0"	2' 9"	2' 6"
3½ × 2	4' 1"	3' 9½"	3' 6"	3' 2½"	2' 11"
4 × 2	4' 8"	4' 4"	4' 0"	3' 8"	3' 4"
4½ × 2	5' 3"	4' 10½"	4' 6"	4' 1½"	3' 9"
5 × 2	5' 10"	5' 5"	5' 0"	4' 7"	4' 2"
6 × 2	7' 0"	6' 6"	6' 0"	5' 6"	5' 0"
7 × 2	8' 2"	7' 7"	7' 0"	6' 5"	5' 10"
8 × 2	9' 4"	8' 8"	8' 0"	7' 4"	6' 8"
9 × 2	10' 6"	9' 9"	9' 0"	8' 3"	7' 6"
11 × 2	12' 10"	11' 11"	11' 0"	10' 1"	9' 2"
		15 inches	17½ inches	20 inches	23½ inches
6 × 2½		7' 6"	7' 0"	6' 6"	6' 0"
7 × 2½		8' 2"	8' 0"	7' 7"	7' 0"
8 × 2½		10' 0"	9' 4"	8' 8"	8' 0"
9 × 2½		11' 3"	10' 6"	9' 9"	9' 0"
11 × 2½		13' 9"	12' 10"	11' 11"	11' 0"
		15 inches	18 inches	21 inches	24 inches
6 × 3		8' 0"	7' 6"	7' 0"	6' 6"
7 × 3		9' 4"	8' 9"	8' 2"	7' 7"
8 × 3		10' 8"	10' 0"	9' 4"	8' 8"
9 × 3		12' 0"	11' 3"	10' 6"	9' 9"
11 × 3		14' 8"	13' 9"	12' 10"	11' 11"

EXPLANATION.—This simple and practical Table gives information that allows the almost instant choice of scantlings, spans and centres of floor joists. As an instance, for 12' 0" clear span of floor joists, 8" × 2" at 17" centres, 8" × 2½" at 21" centres, 7" × 2½" at 15" centres, or 7" × 3" at 18" centres may be used.

TAL
ORS,
able.

S.
nes

6'
1'
4'
9'
2'
0'
0'
3'
5'
2'

nes

r'
r'
r'
r'

es

OWS
an
at

TABLE No. 9

**TRIMMING MEMBERS TO FIREPLACES AND STAIRWELLS AND
JOINTS TO SUCH MEMBERS—ALL FLOORS**

Redwood, Yellow Deal, etc. Non-graded.

TRIMMER JOISTS—RULES AND FORMULA.

Case A, as FIG. 1. Short trimmers not exceeding 4' long to fireplaces.
To be same size as common joists.

Case B, as FIG. 2. Medium length trimmers, not exceeding 5' long to fireplaces, and trimmed joists not exceeding 11' long.

To be same depth and $\frac{1}{4}$ " wider than common joists.

Case C, as FIG. 2. Medium length trimmers, not exceeding 5½' long to fireplaces, and with trimmed joist not exceeding 11' long.

To be same depth and 1" wider than common joists.

Case D, as FIG. 3. Short trimmers to stairwells, not exceeding 4' long with trimmed joists not exceeding 11' long.

To be same size as common joists.

Case E, as FIG. 4. All other cases and long trimmers to stairwells, etc.

Calculate by the following formula :—

SIMPLE FORMULA FOR LONG TRIMMER JOISTS.

Depth of trimmer joist to be same as common joists, but width to be :—

$\frac{1}{4}w + T - (C - S)$ where w = width in inches of *common joists*; T = half length in feet of *trimmed joists*; C = depth in inches of *common joists*; and S = span in feet of *trimmer joist*.

EXAMPLE.—Trimmed joists are 11' long and are supported by a trimmer joist 6' long, the common joist being 9" × 2". What should be the size of trimmer joist?

$$1 + 5\frac{1}{2} - (9 - 6) = 3\frac{1}{2} \text{ inches width.}$$

The size should be 9" × 3½".

NOTE.—The formula is not suitable for very short trimmers as a negative result may be given, but this, however, at once shows that the trimmer may be of same size as common joists.

It is also not suitable for very long trimmers of a span in feet exceeding the depth in inches of common joists; a case which seldom occurs in practice.

In such cases the following formula should be used :—

Breadth of trimmer is to be equal to half the total required breadth of the trimmed joists multiplied by the length of the trimmer and divided by the length of the trimmed joists.

TRIMMING JOISTS—RULES AND FORMULA.

Case F, as FIG. 1. Trimming joist supporting 2 short trimmers, each not exceeding 3' long, and trimmed joists not exceeding 5' long.

To be same depth and 2" wider than common joists.

Case G, as FIG. 2. Trimming joist supporting one trimmer not exceeding 6' long which connects to trimming joist about 3' from its nearest bearing.

To be same depth and 2" wider than common joists.

All other cases as FIGS. 1, 2, 3 and 4.

Calculate by the following simple formula :—

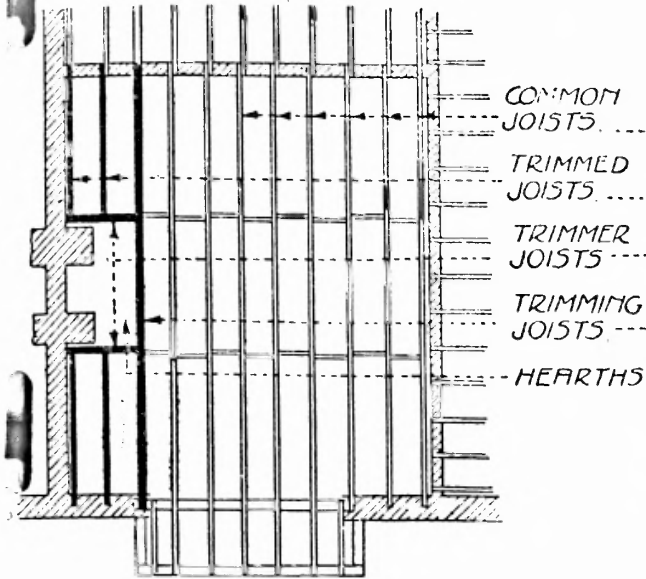

FIG. 1. COMMON JOISTS PARALLEL TO FIREPLACE.

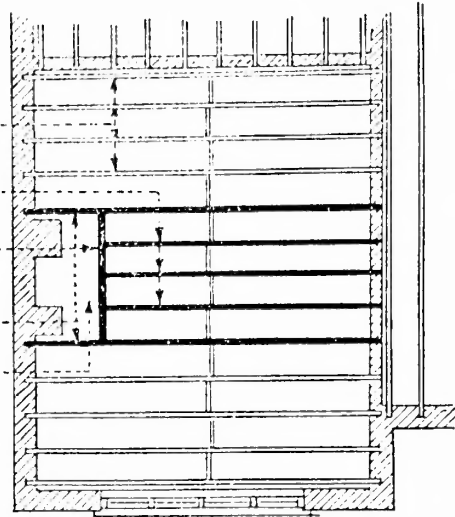

FIG. 2. COMMON JOISTS AT RIGHT ANGLES TO FIREPLACE

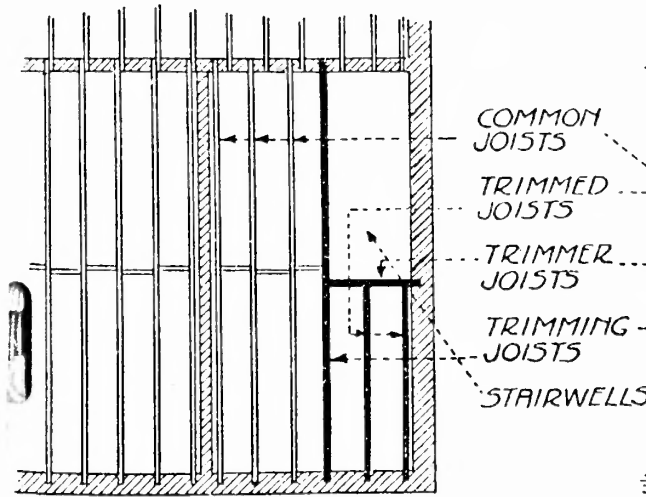

FIG. 3. COMMON JOISTS PARALLEL TO STAIRWELL.

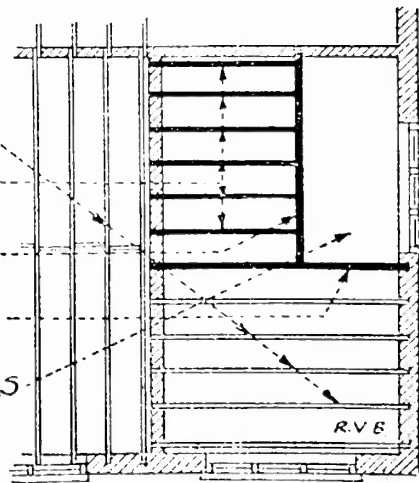

FIG. 4. COMMON JOISTS AT RIGHT ANGLES TO STAIRWELL

SIMPLE FORMULA FOR TRIMMING JOISTS SUPPORTING ONE TRIMMER JOIST.

Depth of trimming joist to be same as common joists but width to be :—

$$\frac{1\frac{1}{2} TD}{S} + w.$$

where T = length in feet of trimmer joist ; D = distance in feet from where the trimmer joist is connected to trimming joist to nearest support of last ; S = Span in feet of trimming joist ; and, w = width in inches of common joists.

EXAMPLE.—Common joists span 15' and are 2" wide. Length of trimmer is 6' and is connected to trimming joist 3' from its nearest bearing.

$$\frac{1\frac{1}{2} \times 6 \times 3}{15} + 2 = 3.8" \text{ or, say, } 4".$$

SIMPLE FORMULA FOR TRIMMING JOISTS SUPPORTING TWO TRIMMER JOISTS.

Depth of trimming joist to be same as common joist but width to be :—

$$\frac{2 TD}{S} + w.$$

where T = length in feet of one trimmer joist ; D = average distance in feet from where the trimmer joists are connected to trimming joist to bearings ; S = span in feet of trimming joist ; and w = width in inches of common joists.

EXAMPLE.—Common joists are 15' long and 2" wide. Length of trimmers is 3', and one is connected 4' from nearest bearing and the other 6' (average is, therefore, 5').

$$\frac{2 \times 3 \times 5}{15} + 2 = 4".$$

N.B.—All the above formula provide for sufficient width of members to allow for loss of sectional area due to jointing.

They are also suitable for floors of all classes of buildings, and not only those of residential buildings.

TYPES OF JOINTS TO USE.

It is of utmost importance that all joints should be at least as strong as the members which they connect. The following simple rules will ensure this in the case of all ordinary floors.

JOINTS BETWEEN MEMBERS OF TIMBER FRAMED FLOORS.

Between Trimmer and Trimmed Joists, where the length of the latter relative to common joists does not exceed :—	Between Trimming Joist and Trimmer where the length of the latter relative to common joists does not exceed :—	
1/3rd ‡	1/6th 1/5th	Half depth housed joint. As FIG. 6. Half depth bevelled housed joint. As FIG. 7. Bevel haunched morticed and tenoned joint. As FIG. 8. Tusk tenoned joint. As FIG. 9.
‡	‡	
Over ‡	Over ‡	

The half depth housed joint, and the half depth bevelled housed joint, should be nailed in addition with strong 4" cut nails.

Plain bearing joints on wall plates and walls, etc., should preferably be 4" and not less than 3" long.

"These copyright tables are reproduced with the kind permission of the Timber Development Association, Ltd., and Mr. R. V. Boughton, A.I. Struct. E."

The following sections of the Hendon Urban District Council Act of 1929 are applicable in this district:—

“ 68.—(1) Where by reason of any improvement made by the Council within the district any land shall become land which adjoins or abuts on any street the following provisions shall apply:—

Elevation of buildings erected on front lands to require approval.

(i) If the owner lessee or occupier of any such land shall construct—

(a) any door or entrance in an existing building communicating with that street; or

(b) any wall or fence by the side of that street;

he shall construct the door entrance wall or fence in such position and in accordance with such elevations as may be approved by the Council;

(ii) If the Council within *six weeks* after any elevations shall have been submitted to them under this section shall have failed to notify their determination in writing to the person submitting the same the Council shall be deemed to have approved of the elevations.

(2) Any person who shall offend against this section shall be liable to a penalty not exceeding *five pounds* and to a daily penalty not exceeding *forty shillings*.

(3) The Council shall make compensation to the owner of any land for any loss or damage he may suffer by reason of the setting back or bringing forward of any wall or fence under the provisions of this section.

69.—(1) In case any building within the district is at any time after the passing of this Act erected or raised to a greater height than the adjoining building and any flues or chimneys of such adjoining building are in the outer or party wall or against the building so erected or raised the person erecting or raising such building shall at his own expense build up those flues and chimneys so that the top thereof may be of the same height as the top of the chimneys of the building so erected or raised or the top of such last-mentioned building whichever may be the higher.

Erection of buildings to greater height than adjoining building.

(2) Any person who shall offend against the provisions of this section shall be liable to a penalty not exceeding *five pounds* and to a daily penalty not exceeding *forty shillings*.

As to
erection of
retaining
walls.

72.—(1) Before any person shall erect on any land a retaining wall of greater height than *six feet* abutting on or adjacent to any street or road he shall submit to the Council plans sections and specifications thereof and no such wall shall be erected except in accordance with such plans sections and specifications as approved by the Council.

(2) Any person who shall erect a retaining wall contrary to the provisions of this section or any owner who after erection shall after reasonable notice in writing from the Council requiring him so to do fail to put such wall in proper repair shall without prejudice to any other right or remedy of the Council be liable to a penalty not exceeding *five pounds* and to a daily penalty not exceeding *forty shillings*.

Food
storage
accommoda-
tion to be
provided.

85.—(1) Every dwelling house erected after the passing of this Act shall be provided with sufficient and properly ventilated pantry or other food storage accommodation and any owner who shall occupy or allow to be occupied any such dwelling-house not so provided shall be liable to a penalty not exceeding *five pounds* and to a daily penalty not exceeding *twenty shillings*.

(2) (a) Every dwelling-house the erection of which was commenced but has not been completed before the passing of this Act shall where reasonably practicable be provided with sufficient and properly ventilated pantry or other food storage accommodation and any owner who shall occupy or allow to be occupied any such dwelling-house which can reasonably be so provided but which is not so provided after *one month's* notice from the Council requiring the same to be done shall be liable to a penalty not exceeding *five pounds* and to a daily penalty not exceeding *twenty shillings*.

(b) Any owner aggrieved by any requirement of the Council under this sub-section may appeal to a court of summary jurisdiction within *seven days* after the service of such notice provided he give *twenty-four hours'* written notice of such appeal and of the grounds thereof to the clerk and the court shall have power to make such order as the court may think fit and to award costs.

(c) Notice of the right to appeal shall be endorsed on every requirement of the Council under this sub-section.

(3) If the owner of the dwelling-house alleges that any occupier should bear or contribute to the expenses of complying with any requirements of the Council under this section he may apply to the county court and thereupon the county court after giving the occupier an opportunity of being heard may make such order as appears to the court just and equitable in all the circumstances of the case.

90.—(1) The contractor or builder engaged in or upon the erection of a new building or the construction or reconstruction of any works shall where practicable provide to the reasonable satisfaction of the Council and until the completion of any such erection construction or reconstruction maintain such water or other closets and urinals in or in connection with such building or works as may be sufficient for the accommodation of the workmen employed.

Sanitary conveniences for workmen engaged on buildings.

(2) Any person who shall offend against this section shall be liable to a penalty not exceeding *five pounds* and to a daily penalty not exceeding *forty shillings*."

INDEX.

	<i>Clause.</i>
Application of byelaws	2
Cesspools, etc.	135 and 136
Chimneys and flues	55 to 84
Dimensions of rooms	115
Drainage	116 to 131
Earthclosets	134
Exemptions	3 to 8
Floors	85 to 91
Foundations	21 to 23
Interpretation of terms	1
Loading	First Schedule
Materials used in the construction of buildings	9 to 17
Notices, plans, etc.	143 to 147
Penalties	148
Plans, notices, etc.	143 to 147
Prescribed period	149
Repeal of byelaws	150
Roofs	96 and 97
Short-lived materials	98
Sites	18 to 20
Space about buildings	99 to 106
Stoves and other fittings	139 to 142
Urinals	133
Ventilation of buildings	107 to 113
Walls	24 to 54
" —Exception for certain domestic buildings	25
" —General byelaws as to construction	30 to 54
" —Pressures	Second Schedule
" —Special classes	26 to 29
Waterclosets	132
Water tanks and cisterns	138
Wells	137

Reports of Committees.

Report of the Education Committee.

4th July, 1939.

COMMITTEE:

*Alderman J. J. Copestake, J.P. (*Chairman*).

Aldermen:

*S. H. Egan, J.P.
B. Flowers,

*W. M. Maughan, J.P.,

B. J. Monro.

Councillors:

*E. Arter, M.C., M.I.A.E.,

*A. A. Naar, M.B.E.,

*W. H. N. Shakespeare,
M.C., A.F.C., J.P.,

*H. Connell, J.P.,

*(Mrs.) F. E. Parvin,

*H. P. Small,
(Mrs.) M. Thomas.

*A. W. Gurton,

T. Pugh,

*G. H. Hignett,

*G. R. Richardson,

*P. Lightfoot,

T. J. Scott,

Co-opted:

*Mrs. S. J. Bannister,
L.L.A.,

*Major N. G. Brett
James, M.A.,

*The Rev. P. G. Howell,
*The Rev. I. Livingstone.

*The Rev. N. R. Boyd,
M.A.,

B.Litt., F.S.A.,

• *denotes Member present.*

MINUTES:

The Minutes of the Meetings held on the 23rd May, 1939, were read, confirmed and signed.

CORRESPONDENCE:

The various letters had been referred to the respective Sub-Committees.

REPORT OF PUBLIC HEALTH AND MEDICAL SERVICES COMMITTEE:

RESOLVED—

THAT the following extract from the report of the above Committee, dated 26th June, 1939, be received:—

REPORT OF SCHOOL MEDICAL OFFICER.

I. STATISTICAL INFORMATION:

Statistics for the six weeks ended on the 17th June, were submitted and are summarised in the appendix to the report of the Finance and General Purposes Committee.

II. DEFECTIVE CHILDREN:

On the report of the School Medical Officer, it was

RESOLVED TO RECOMMEND—That in the undermentioned cases action be taken as follows:—

Case.	Defect.	Recommendation.
M.L., N.W.9. 16/5/29. Barnfield.	Debility following acute rheumatism and carditis	Three months' convalescence.
G.B., Burnt Oak. 12/9/28. Barnfield.	Chorea	Three months' convalescence at a suitable Heart Home and the case reviewed at the expira- tion of that period with a view to an extension, if necessary.
M.C., Burnt Oak. 23/5/32. Annunciation.	Bronchitis and general debility	Four weeks' convalescence.
M.B., Burnt Oak. 24/2/33. Goldbeaters.	General debility following lobar pneumonia	Three months' convalescence.
F.H., N.W. 2. 15/6/31. Clitterhouse	Carditis	Three months' convalescence at a suitable Heart Home and the case reviewed at the expira- tion of that period with a view to an extension, if necessary.
R.B., N.W. 9. 2/5/32. Hyde.	General debility	Four weeks' convalescence.
H.H., N.W. 2. 26/1/34. Childs Hill.	General debility after severe whooping cough and recent tonsillitis	Two months' convalescence.
D.F., N.W. 7. 16/6/31. Oak Lodge.	Imbecile	Notification to the Middlesex County Council.
F.B., Burnt Oak. 9/7/23. Oak Lodge.	Mentally Defective (feeble- minded) low grade	Notification to the Middlesex County Council.

III. CASES OF UNDER-NOURISHMENT:

Arising out of the report of the School Medical Officer, instructions were given for arrangements to be made, if possible, for under-nourished school children to be supplied with milk during the Summer Holidays.

IV. MENTAL HEALTH EMERGENCY COMMITTEE:

A communication was considered from the above Committee dealing with the proposed steps which could be taken by authorities, especially reception authorities, to minimise the mental repercussion of the state of war.

The Committee decided to take no action thereon at the present time.

V. REQUISITIONS:

Requisitions amounting to the sum of £98 14s. 0d. were submitted and approved.

Moved by Councillor Hignett, duly seconded, and RESOLVED—

THAT the foregoing extract from the Report of the Public Health and Medical Services Committee be approved and adopted.

SCHOOL MANAGEMENT SUB-COMMITTEE:

RESOLVED—

THAT the following Report be received:—

20th June, 1939.

SUB-COMMITTEE:

Alderman B. Flowers (Chairman).

Aldermen: *J. J. Copestake, J.P., W. M. Maughan, J.P.,
(Presiding).

Councillors: E. Arter, M.C., M.I.A.E., *T. Pugh, *T. J. Scott,
*P. Lightfoot, *C. R. Richardson, (Mrs.) M. Thomas,
*A. A. Naar, M.B.E.,

Co-opted: *Major N. G. Brett *The Rev. P. G. Howell.
James, M.A.,
B.Litt, F.S.A.,

* denotes Member present.

Apologies for absence were submitted on behalf of Aldermen B. Flowers and W. M. Maughan.

1.—REPORTS OF H.M. INSPECTOR:

H.M. Inspector's Reports on his inspection of the undermentioned schools were submitted:—

School.	Inspected on:—
Burnt Oak Mixed and Infants'	24th April and 2nd May, 1939.
Colindale Junior Mixed & Infants'	19th and 25th April, 1939.
Wessex Gardens Boys'	21st April, 1939.

RESOLVED TO RECOMMEND—

- (a) THAT the Reports on the Burnt Oak and Colindale Schools be noted with satisfaction.
- (b) THAT the Head Teacher of the Wessex Gardens Boys' School be asked for his observations on H.M. Inspector's Report on his School.

2.—ALGERNON ROAD JUNIOR MIXED SCHOOL:

In accordance with the Committee's decision, the observations of Mr. L. A. Kitchen, the Head Teacher of the Algernon Road Junior Mixed School, on H.M. Inspector's Report on his inspection of the school on the 27th February, 1939, were submitted. The Director of Education received instructions thereon.

3.—ORANGE HILL CENTRAL BOYS' SCHOOL:

The observations of Mr. F. W. Roberts, Head Teacher of the Orange Hill Central Boys' School on H.M. Inspector's Report on his inspection of the school on 31st March and 3rd April, 1939, were submitted and noted.

4.—COMMUNITY CENTRES:

(a) CLITTERHOUSE ESTATE:

It was reported that on the 19th June, 1939, the Borough Council passed the following resolution:—

"THAT the Education Committee be authorised to inform the County Education Authority that, subject to the consent of the Minister of Health and to the removal of the restrictive covenants, the Hendon Town Council are prepared to grant a lease of 21 years on approximately one-half acre of land at a nominal rental of £10 per annum, on the Clitterhouse Open Space for the erection of a Community Centre."

RESOLVED TO RECOMMEND—

THAT action be taken accordingly.

(b) WATLING ASSOCIATION:

A letter was submitted from the Middlesex Local Education Authority forwarding revised plan of the proposed extensions of the Watling Community Centre and asking that early consideration might be given to the question of a contribution by the Hendon Borough Council to the cost thereof which is now estimated at approximately £11,000.

RESOLVED TO RECOMMEND—

THAT the revised plan and letter from the Middlesex Education Committee be referred to the appropriate Committee of the Borough Council.

5.—BROADFIELDS ESTATE:

A letter was submitted from Mr. W. Gibson enclosing a Petition from certain parents residing on the Broadfields Estate strongly protesting against the distance children have to travel to the Edgware School, and asking for the provision of transport. Mr. Gibson asks further whether the Committee would be prepared to receive a deputation in connection therewith.

RESOLVED TO RECOMMEND—

THAT such deputation be received by this Sub-Committee at their next meeting to be held on 19th September, 1939.

6.—UNITED SOCIETY FOR CHRISTIAN LITERATURE:

A letter was submitted from the United Society for Christian Literature forwarding particulars of their Bible Knowledge Foundation which exists for the purpose of encouraging the knowledge of the Bible in the Day Schools throughout the land. **Noted.**

7.—REFUND OF EXAMINATION FEES:

Particulars were submitted of scholars of the St. Mary's C.E. Senior and Orange Hill Central Girls' Schools who had been successful in passing recent examinations of the Royal Society of Arts.

RESOLVED TO RECOMMEND—

THAT the entry fees amounting to £12 5s. 6d. be refunded.

8.—A.R.P.—EVACUATION OF SCHOOL CHILDREN:

The Director of Education reported that a letter had been received from the Education Officer of the London County Council, pointing out that, if an emergency occurred during school holidays, there would not be sufficient teachers available in London to carry out the scheme for the evacuation of children in the L.C.C. and neighbouring evacuation areas. It had been decided, therefore, to ask teachers in neighbouring neutral areas whether they would be prepared to volunteer to help in such an emergency, provided, of course, they were not away from London at the time. Such teachers would not be required in the Reception areas for any length of time; moreover, they would be given free lodging and for their return journey would be provided with a free railway voucher.

RESOLVED TO RECOMMEND—

- (a) **THAT the Education Committee raise no objections to members of their teaching staffs volunteering for service during the summer holiday period on the understanding that no liability whatsoever is accepted in connection therewith.**
- (b) **THAT all teachers who offer such voluntary service shall be available for duty on the day the schools re-open after the Summer Holidays.**

9.—REQUISITIONS:

Requisition Sheets Nos. 297/9, amounting to £2,174 9s. 0d., were submitted and approved.

Moved by Councillor Lightfoot, duly seconded, and RESOLVED—

THAT the Report of the School Management Sub-Committee be approved and adopted.

WORKS SUB-COMMITTEE:

RESOLVED—

THAT the following Report be received:—

20th June, 1939.

SUB-COMMITTEE:

*Councillor **W. H. N. Shakespeare, M.C., A.F.C., J.P.** (*Chairman*).

Aldermen:	S. H. Egan, J.P.,	B. J. Monro.	
Councillors:	H. Connell, J.P.,	*C. H. Hignett,	*H. P. Small.
	A. W. Curton,	*(Mrs.) F. E. Parvin,	
Co-opted:	*(Mrs.) S. J. Bannister,	The Rev. N. R. Boyd,	*The Rev. I. Livingstone.
	L.L.A.,	M.A.,	

* denotes Member present.

Apologies for absence were submitted on behalf of Aldermen Egan and Monro.

1.—ANNUAL REDECORATIONS TO SCHOOLS:

Consideration was given to the report of the Borough Surveyor on tenders received for the above. Details of the tenders are given in the lists circulated to Members and set out in MSS. in the Sub-Committee's Minute Book.

RESOLVED TO RECOMMEND—

THAT the following tenders be accepted for carrying out the works mentioned in accordance with the Surveyor's specification, that the Surveyor be authorised to supervise the execution of the works, and that the Corporate Seal be affixed to the necessary Contracts, viz.:—

Messrs. Buckingham & Sons Ltd.:—	£	s.	d.
External redecoration—Colindale School and Bungalow	169	0	0
External redecoration—Woodcroft School and Cottage	195	0	0
Internal redecoration—St. Mary's R.C. School	95	0	0
Internal redecoration—St. Paul's C.E. School	76	0	0

Messrs. Garsubil Ltd.:—

	£	s.	d.
External redecoration—Algernon Road School and Cottage	169	0	0
External redecoration—Brent Modern School and Bungalow	278	0	0
External redecoration—The Meads School	81	0	0

Mr. J. N. Jones:—

Internal redecoration—Goldbeaters School and Cottage	390	0	0
--	-----	---	---

[Having considered the matter in its financial bearing, the Finance and General Purposes Committee concur in the proposals.]

2.—SITE FOR TWO NEW SENIOR SCHOOLS AT CLAREMONT ROAD:

The Surveyor reported that, after preparing sketch plans for these schools on the site originally agreed by the Committee, he had come to the conclusion that it would be advisable for the Committee to reconsider the question of the site, as the preliminary estimates proved conclusively that the original site proposed was too expensive. A plan showing 10.5 acres of land slightly to the south of the original site was submitted and considered by the Committee to be more suitable.

RESOLVED TO RECOMMEND—

- (a) **THAT the revised site plan be approved and that any previous Minute inconsistent herewith be rescinded.**
- (b) **THAT the Town Clerk be instructed to apply to the Ministry of Health for appropriation of the land in question for educational purposes and that subsequently application be made to the Board of Education for approval of the site.**

AMENDMENT moved by Councillor Shakespeare, duly seconded, and**RESOLVED—**

- (a) **THAT the foregoing recommendations (a) and (b) be deleted.**
- (b) **THAT application be made to the Finance and General Purposes Committee for approval to the allocation of 10.5 acres of land shown on the plan submitted.**

(See Finance and General Purposes Committee Report, 10/7/39—21)

3.—BROADFIELDS AVENUE SCHOOL SITE:

It was reported that the award of the Arbitrator in this case had been received.

RESOLVED TO RECOMMEND—

THAT the Corporation authorise application to the Board of Education for approval of the site and to the Ministry of Health for sanction to raising a loan of £8,855, made up as follows:—

	£
Cost of land, per Arbitrator's award	8,320
Costs of the Claimants	240
Costs of arbitration	119
Costs of conveyance	87
Cost of raising loan, etc.	89
	£8,855

[Having considered the matter in its financial bearing, the Finance and General Purposes Committee concur in the proposal.]

4.—GOLDBEATERS COUNCIL SCHOOL—AIR RAID PRECAUTIONS:

Pursuant to Item 10 in the Report of this Sub-Committee, dated 9/5/39, the Chairman reported further on the letter received from Mr. E. Sewell Harris.

RESOLVED TO RECOMMEND—

THAT a reply be forwarded to Mr. Harris in the terms stated.

5.—WESSEX GARDENS COUNCIL SCHOOL:

RESOLVED TO RECOMMEND—

THAT the Surveyor be authorised to arrange for repairs to be carried out to the floor of the Senior Hall at this School, at an estimated cost of £45.

[Having considered the matter in its financial bearing, the Finance and General Purposes Committee concur in the proposal.]

6.—THE MEADS COUNCIL SCHOOL:

RESOLVED TO RECOMMEND—

THAT the Surveyor be authorised to accept the quotation of Mr. C. E. Keates, amounting to £47, for electric light installations at this School.

[Having considered the matter in its financial bearing, the Finance and General Purposes Committee concur in the proposal.]

7.—LIGHT CONSTRUCTION SCHOOL BUILDINGS:

Board of Education Circular 1468 regarding the use of methods of light construction buildings for elementary school purposes, and the extension of loan periods in connection therewith, was submitted and **noted.**

8.—BROADFIELDS AVENUE JUNIOR AND INFANT SCHOOL:

(a) SITE:

It was reported that Notice of Entry had been served upon Messrs. John Laing and Son Ltd. and that possession of the land could be taken on 19th June, 1939. **Noted.**

(b) ERECTION OF BUILDINGS:

A communication was submitted from the Board of Education approving the Authority's proposal for the erection of the above-named school, subject to the observations mentioned. It was reported that the revised amount of the accepted tender was £24,408 8s. 3d. and that the Contractors commenced work on 19th instant. **Noted.**

(c) APPOINTMENT OF CLERK OF WORKS:

RESOLVED TO RECOMMEND—

THAT Mr. W. M. Ross be appointed Clerk of Works for this contract with wages at the rate of £7 7s. 0d. per week, for duty commencing on 23rd June, 1939, and that the engagement be determinable by one month's notice on either side.

[The Finance and General Purposes Committee concur in the proposed appointment]

9.—DOLLIS JUNIOR AND INFANT SCHOOL:

(a) WATER HEATERS:

RESOLVED TO RECOMMEND—

THAT authority be given for an agreement to be entered into with the North Middlesex Gas Co. for the maintenance of four gas heated water storage cylinders at this School at a total cost of £5 per annum.

(b) SCHOOL HALL:

RESOLVED TO RECOMMEND—

THAT the use of the School Hall at this School by members of the Boys' Club mentioned be continued only on the understanding that the boys in question wear suitable shoes which will not mark the floor.

£ s. d.
169 0 0
278 0 0
81 0 0
390 0 0

ools on the
at it would
preliminary
ve. A plan
mitted and

ous Minute

f Health for
s and that
or approval

mittee for
mitted.

received.

ucation for
to raising

£
8,320
240
119
87
89
£8,855

oses

the Chair-

10.—ST. JAMES' R.C. CENTRAL SCHOOL—STUDY ROOM:

A communication was submitted from the Board of Education approving the work shown on the plans for the provision of a Study Room at this school, subject to the observations mentioned. It was reported that a copy of this communication, together with the plans, had been forwarded to the Managers for attention. **Noted.**

11.—EDGWARE JUNIOR AND INFANT SCHOOL:

RESOLVED TO RECOMMEND—

THAT the Borough Surveyor be instructed to arrange for the provision of suitable curtains or blinds to the Hall Windows at this school, for use in connection with a cinema projector, at a cost not exceeding £40.

[Having considered the matter in its financial bearing, the Finance and General Purposes Committee concur in the proposal.]

12.—CRESSINGHAM ROAD AND THE BURROUGHS PLAYING FIELDS:

A report was submitted from the Director of Education regarding the provision of additional storage accommodation for sports apparatus at the above-named playing fields.

RESOLVED TO RECOMMEND—

THAT the report be referred to the Borough Surveyor and that he be instructed to submit an estimate of cost in due course.

13.—REQUISITIONS:

Requisition Sheet No. 273, amounting to £425 6s. 3d., was submitted and **approved.**

Moved by Councillor Shakespeare, seconded by Councillor Hignett, and

RESOLVED—

THAT the Report (as amended) of the Works Sub-Committee be approved and adopted.

STAFFS AND SALARIES SUB-COMMITTEE:

RESOLVED—

THAT the following Report be received:—

20th June, 1939.

SUB-COMMITTEE:

Councillor E. Arter, M.C., M.I.A.E. (Chairman).

Aldermen:	*J. J. Copestake, J.P.,	B. Flowers,	W. M. Maughan, J.P.
	<i>(Presiding),</i>		
Councillors:	*P. Lightfoot,	*T. Pugh,	*T. J. Scott,
	*A. A. Naar, M.B.E.,	*C. R. Richardson,	(Mrs.) M. Thomas
Co-opted:	*Major N. C. Brett	*The Rev. P. C. Howell.	
	James, M.A.,		
	B.Litt., F.S.A.,		

** denotes Member present.*

Apologies for absence were submitted on behalf of Aldermen B. Flowers and W. M. Maughan, and Councillor E. Arter.

1.—APPOINTMENTS FROM TRAINING COLLEGES, 1939:

It was reported that in accordance with authority delegated, Councillor E. Arter and the Director of Education had interviewed further students who were leaving College this year, and had RESOLVED—

“ THAT the undermentioned students be appointed Certificated Assistant Teachers on the Committee's staff as from 29th August, 1939, in full-time service exclusively in the capacity of teachers in accordance with the conditions of employment under Article 17 of the Code, and subject to the conditions of appointment of the Committee in force from time to time and upon the terms and subject to the conditions of the Burnham Arbitration Award and the decisions of the Board of Education relating thereto, or upon the terms and subject to the conditions of any other scale of salaries that may be adopted by the Committee, the engagements to be determinable on either side by a notice of one calendar month:—

National Training College of Domestic Subjects:—

Griffiths, Elizabeth E. M.

McKerchar, Grace M. A.

Westminster Training College:—

Aldred, Fred S.

Johnson, B.A., Arthur S.

Kedward, Kenneth R.

Rivers, B.Sc., Frederick A.

Robinson, B.Sc., Albert.”

Noted.

2.—APPLICATIONS FOR APPOINTMENT AS ASSISTANT MISTRESSES:

It was reported that applications for appointment as Certificated Assistant Mistresses had been received from Miss Agnes M. Loggie of Ayrshire, Miss Katherine S. Allen of Catford and Miss Mavis E. Baker of Birmingham.

RESOLVED TO RECOMMEND—

(a) **THAT, subject to the submission of a satisfactory medical certificate, Miss Agnes M. Loggie be appointed Certificated Assistant Teacher on the Committee's staff as from 1st September, 1939, in full-time service exclusively in the capacity of a teacher in accordance with the conditions of employment under Article 17 of the Code, and subject to the conditions of appointment of the Committee in force from time to time and upon the terms and subject to the conditions of the Burnham Arbitration Award and the decisions of the Board of Education relating thereto, or upon the terms and subject to the conditions of any other scale of salaries that may be adopted by the Committee, the engagement to be determinable on either side by a notice of one calendar month.**

(b) **THAT Miss Allen and Miss Baker be informed that there are no suitable vacancies on the Committee's staff at present.**

3.—ALL SAINTS' C.E. SCHOOL:

A letter was submitted from the Managers of the All Saints' C.E. School recommending the appointment of Miss Yvonne K. Richardson as Certificated Assistant Mistress as from 1st July, 1939.

RESOLVED TO RECOMMEND—

THAT consent be given to the appointment, subject to the completion of an agreement with the Managers.

4.—APPOINTMENT OF STUDENT TEACHERS, 1939/40:

Applications for appointment as Student Teachers were submitted from Mr. Frederick H. Alexander and Miss Beryl G. Thomson.

RESOLVED TO RECOMMEND—

THAT, subject to their reaching matriculation standard in the General Schools Examination of June, 1939, and to their passing the medical examination of the Medical Officer of Health, Frederick H. Alexander and Beryl G. Thomson be appointed as Student Teachers for the year 1st September, 1939, to 31st August, 1940, with salaries at the rate of £40 per annum.

5.—MEN TEACHERS AND NATIONAL SERVICE:

Board of Education Circular 1470 was submitted, stating that:—

- (1) Men over 38 will not be accepted for the Territorial Field Army.
- (2) For Auxiliary Air Force:—

Pilots—over 30	} will not be accepted.
Aircraft Crew—over 32	
Vol. Reserve Pilots—over 25	
- (3) Teachers so ruled out of active service should stay in school (unless having special qualifications for Defence Service).
- (4) Teachers volunteering for service with H.M. Forces with the sanction of the local education authority will have salary and pension interests safeguarded by statute.
- (5) Teachers in areas to be evacuated will have seven days' grace, with their calling-up notices, if their school services are required. (This does not apply to Auxiliary Air Force Flying Squadrons.) **Noted.**

6.—SCHOOL CARETAKERS—MILITARY SERVICE:

It was reported that two School Caretakers, Mr. W. J. Martin of the All Saints' C.E. School and Mr. A. H. Steeds of the Dollis Council School, had been called up for Military Service under the Reserve and Auxiliary Forces Act, 1939, for one month beginning on 18th June, 1939. **Noted.**

7.—SCHOOL CARETAKER—ANNUAL INCREMENT:

RESOLVED TO RECOMMEND—

THAT an annual increment according to scale be granted to Mr. F. J. Nash, Caretaker of the Burnt Oak Council School, as from 11th July, 1939.

8.—BROADFIELDS TEMPORARY SCHOOL—"CLEANER" HOURS:

A letter was submitted from the Rev. H. A. H. Lea asking whether the Committee would agree to grant a cleaning allowance of four hours per week to the Caretaker of the St. Andrew's Church Hall in view of the extra cleaning to be done as a result of the increased enrolment at the school.

RESOLVED TO RECOMMEND—

THAT such cleaning allowance be made as from 6th July, 1939.

9.—TEACHERS' SALARIES—SPECIAL ALLOWANCES:

In pursuance of the resolution of the Education Committee of 23rd May, 1939, it was RESOLVED TO RECOMMEND—

THAT for the financial year 1st April, 1939, to 31st March, 1940, a special allowance of two additional increments under Section 14 of the Burnham Elementary Report, 1938, be paid to each of the following teachers in virtue of the post of special responsibility which she occupies on the staff of the school mentioned:—

Teacher.	School.
Wilson, Ethel M.	Clitterhouse Junior Mixed and Infants'.
Law, Eleanor Y.	Colindale Junior Mixed and Infants'.
Price, Mona	Frith Manor Junior Mixed and Infants'.

10.—BOARD OF EDUCATION SHORT COURSES FOR TEACHERS:

A letter was submitted from Miss Joan Stevens of the Goldbeaters Infants' School applying for special leave of absence from 23rd September to 16th December, 1939, to enable her to attend a course for Infant School Teachers at Whitelands Training College under Board of Education Circular 1453.

RESOLVED TO RECOMMEND—

THAT leave of absence with salary be granted accordingly, and that application be made to the Middlesex Local Education Authority for the payment of tuition fees and travelling expenses incidental to attendance at the course.

11.—RESIGNATIONS:

RESOLVED TO RECOMMEND—

THAT the undermentioned resignations be accepted:—

Bates, Kathleen I.	St. Mary's C.E. Senior	28th August, 1939.
Collinge, Alice M.	Wooderoft Junior	30th June, 1939.
Haydon, Elizabeth M.	Brent Modern	28th August, 1939.
Moyes, Edith C.	Wooderoft Infants'	30th June, 1939.
Rowley, Eileen F.	Wooderoft Infants'	30th June, 1939.

12.—ABSENCES OF TEACHERS, ETC.:

(a) GENERAL LIST:

A Statement with regard to the absences of 51 teachers, etc., was submitted and **noted.**

(b) SPECIAL CASE—MRS. C. HARROP:

The Director of Education reported that Mrs. C. Harrop of the Barnfield Junior Mixed School returned to duties on 25th May, 1939. **Noted.**

Moved by Councillor Arter, seconded by Councillor (Mrs.) Parvin, and

RESOLVED—

THAT the Report of the Staffs and Salaries Sub-Committee be approved and adopted.

SCHOOL ATTENDANCE SUB-COMMITTEE:

RESOLVED—

THAT the following Report be received:—*20th June, 1939.***SUB-COMMITTEE:*****Councillor C. H. Hignett** (*Chairman*).

Aldermen: S. H. Egan, J.P., B. J. Monro.
Councillors: H. Connell, J.P., *(Mrs.) F. E. Parvin, *W. H. N. Shakespeare,
 A. W. Curton, *H. P. Small, M.C., A.F.C., J.P.
Co-opted: *(Mrs.) S. J. Bannister, The Rev. N. R. Boyd, *The Rev. I. Livingstone,
 L.L.A., M.A.,

* denotes Member present.

Apologies for absence were submitted on behalf of Aldermen Egan and Monro.

1.—JUVENILE COURT PROCEEDINGS:

Particulars of cases dealt with during the period 5th May, 1939, to 15th June, 1939, were submitted as follows:—

Charges and Summonses: Young People 15, Children 12, Total 27.

Offence.	Sex and age of Child or Young Person.	Action taken.
At Wealdstone:—		
Larceny	Boy, 13 years	4 Strokes of Birch.
Larceny	Boy, 13 years	Probation 1 year.
Larceny	Boy, 13 years	Probation 1 year.
Larceny	Boy, 12½ years	Probation 2 years.
Larceny	Boy, 11 years	Probation 1 year.
Larceny	Boy, 13½ years	Dismissed P.O. Act.
Larceny	Boy, 12 years	Dismissed P.O. Act.
Larceny	Boy, 9½ years	Dismissed P.O. Act.
Larceny	Boy, 12 years	Dismissed P.O. Act.
Larceny	Girl, 16 years	Probation 1 year.
Breach of recognizance	Boy, 15 years	To Hostel.
Breach of recognizance and larceny	Boy, 15 years	Remanded to 21/6/39.
Found on enclosed premises	Boy, 10½ years	Adjourned sine die.
Wilful damage	Boy, 16½ years	Costs 10/-.
Wilful damage	Boy, 16 years	Costs 10/-.
Wilful damage	Boy, 15½ years	Probation 1 year.
Wilful damage	Boy, 13 years	Dismissed P.O. Act.
Wilful damage	Boy, 14½ years	Costs 10/-.
Wilful damage	Boy, 16 years	Probation 1 year. Costs 10/-.

Offence.	Sex and age of Child or Young Person.	Action taken.
Wantonly discharging fire-arm	Boy, 14½ years	Fined 20/-.
Wantonly discharging fire-arm	Boy, 14 years	Fined 20/-.
Playing football in street	Boy, 16 years	Dismissed P.O. Act.
Playing football in street	Boy, 16 years	Dismissed P.O. Act.
Playing football in street	Boy, 15 years	Dismissed P.O. Act.

At Uxbridge:—

Shopbreaking (after absconding from Approved School)	Boy, 16½ years	Returned to Approved School.
--	----------------	------------------------------

At Hendon:—

Wilful damage	Boy, 13 years	Costs 10/-.
Wilful damage	Boy, 14½ years	Costs 10/-.

Noted.**2.—SCHOOL ATTENDANCE:**

(a) Statistics of Attendance were submitted as follows:—

(i) **Percentages:—**

Week ended 5th May, 1939	91.7
Week ended 12th May, 1939	92.2
Week ended 19th May, 1939	89.6
Week ended 26th May, 1939	88.9
Week ended 2nd June, 1939	90.8

(ii) **Statistics for the week ended 9th June, 1939:—**

Number on Roll	14,575
Average Attendance	13,335
Percentage of Attendance	91.4

Noted.(b) **IRREGULAR ATTENDANCE:****RESOLVED TO RECOMMEND—**

THAT summonses be issued against the parents in respect of the irregular attendance of Rosalind Smith and Clifford Hardy.

(c) **EXTRA-DISTRICT CHILD:**

A letter was submitted from the parent of Arthur Edward Harvey, asking the Committee to defray the cost of the boy's travelling expenses in connection with his attendance at the London County Council Rotherhithe New Road Nautical School. The Committee have accepted responsibility for the cost of the boy's education at this school (Vide Minute No. 2 (c) of the School Attendance Sub-Committee, dated 31st January, 1939).

RESOLVED TO RECOMMEND—

THAT Mr. Harvey be informed that the Committee are unable to accede to his request.

3.—EMPLOYMENT OF CHILDREN:

The report of the Employment Officer for the period 4th May, 1939, to 14th June, 1939, was submitted as follows:—

	Boys.	Girls.
Employment Cards and Badges Issued	30	—
Employment Badges Returned	16	—
New Permits granted:—		
Delivery of Newspapers	17	—
Delivery (Shops)	12	—
Delivery of Milk	1	—
Medically examined (Certificates granted)	14	—
Medically examined (Certificate refused)	1	—
Number of children employed at date	298	10

Noted.

4.—FRITH MANOR SCHOOL—LETTER FROM PARENT:

A letter was submitted from Mr. M. Bowden of Lee Road, Mill Hill, asking the Committee to provide a conveyance for the children attending the Frith Manor Council School in view of the distance the children are required to walk and the danger of traffic along Frith Lane, which is practically without adequate footpaths, particularly during the winter months.

RESOLVED TO RECOMMEND—

THAT Mr. Bowden be informed that, as the distance to be travelled is less than the statutory limit of two miles as laid down in the School Attendance Byelaws, the Committee regret they are unable to accede to his request for the provision of a conveyance.

5.—SCHOOL ATTENDANCE BYELAWS—EDUCATION ACT, 1936:

Board of Education Administrative Memorandum No. 193, dated 9th June, 1939, was submitted. The Board state that in connection with the raising of the school leaving age to fifteen years from the 1st September, 1939, being the Appointed Day under the Education Act, 1936, they have had under consideration the question of the revision, where necessary, of the School Attendance Byelaws made by local education authorities.

Section 1 of the Act, which provides for the raising of the age, does not in any case necessitate any actual revision of the existing byelaws, since the enactment itself expressly provides that existing byelaws shall have effect as if the age of fifteen were substituted for any lower age specified in the byelaws. Accordingly the Board have no occasion, generally speaking, to recommend the making of new School Attendance Byelaws. **Noted.**

Moved by Councillor Hignett, duly seconded, and RESOLVED—

THAT the Report of the School Attendance Sub-Committee be approved and adopted.

FINANCE AND GENERAL PURPOSES SUB-COMMITTEE:

RESOLVED—

THAT the following Report be received:—

20th June, 1939.

SUB-COMMITTEE:

Councillor A. W. Curton (*Chairman*).

Aldermen: *J. J. Copstake, J.P., S. H. Egan, J.P., B. J. Monro.
(Presiding). B. Flowers,

Councillors: E. Arter, M.C., M.I.A.E., *C. R. Richardson, (Mrs.) M. Thomas.
 *C. H. Hignett, *W. H. H. Shakespeare,
 *T. Pugh, M.C., A.F.C., J.P.,

* denotes Member present.

Apologies for absence were submitted on behalf of Aldermen Egan, Flowers and Monro.

1.—MAINTENANCE OF SCHOOL WEIGHING MACHINES, ETC.:

RESOLVED TO RECOMMEND—

THAT the estimate of Messrs. C. Pollard Ltd., N. 1, be accepted for cleaning, testing and balancing three times per year, during school holidays, weighing machines and infant weighing scales in the various schools and clinics, as per list submitted, for the period 1st July, 1939, to 30th June, 1940, at a total cost of £15 3s. 0d.

[Having considered the matter in its financial bearing, the Finance and General Purposes Committee concur in the proposal.]

2.—SMOKING IN SCHOOLS USED FOR LETTING PURPOSES:

RESOLVED TO RECOMMEND—

THAT notices in the terms mentioned be displayed in Schools let for meetings and social functions.

3.—BOARD OF EDUCATION APPROVALS:

The following approvals by the Board of Education were submitted and noted.

- (a) Grant to Hendon Schools Sports Association—£100.
- (b) Stripping and re-tiling roof of Burnt Oak School—£400.
- (c) The Meads Council School playground—£180.

4.—ST. AGNES' R.C. SCHOOL—DECORATION OF PREMISES:

In connection with the modernisation of the present building, a communication was considered from the Managers asking the Committee to make a monetary grant equivalent to the amount they would ordinarily expend on the redecoration of the existing school.

RESOLVED TO RECOMMEND—

THAT the Borough Surveyor be instructed to submit an estimate of the cost of redecorating the three existing rooms mentioned for consideration by the Sub-Committee at its next meeting.

5.—ADMINISTRATIVE STAFF:

In accordance with authority delegated, it was

RESOLVED TO RECOMMEND—

THAT, subject to a satisfactory medical examination, Mr. Ivan Walter Robert Hsley, be appointed to the permanent staff of the Corporation in the Education Department for duty as from a date to be arranged, with salary in accordance with the Council's scale.

(The Finance and General Purposes Committee concur in the proposed appointment.)

6.—WORKS SUB-COMMITTEE MATTERS:

The following items which had been sanctioned by the Works Sub-Committee were submitted and **approved**:—

	£	s.	d.
Annual redecorations to schools	1,453	0	0
Broadfields Avenue School Site:—			
(a) Loan Sanction	8,855	0	0
(b) Clerk of Works, Appointment of Mr. W. M. Ross—per week	7	7	0
Wessex Gardens Senior School —Repairs to Hall Floor	45	0	0
The Meads School —Electric light installation	47	0	0
Dollis Junior and Infant School —Maintenance of gas heated water storage cylinders—per annum	5	0	0
Edgware Junior and Infant School —Curtains or blinds for Hall windows	40	0	0

7.—REQUISITIONS:

Requisitions which had been sanctioned by the School Management Sub-Committee (£2,174 9s. 0d.) and the Works Sub-Committee (£425 6s. 3d.) were submitted and **approved**.

Moved by Councillor Curton, seconded by Councillor Arter, and **RESOLVED**—

THAT the Report of the Finance and General Purposes Sub-Committee be approved and adopted.

AIR RAID PRECAUTIONS IN SCHOOLS:

It was reported that a communication had been received from the Minister of Health stating that the Borough of Hendon is not among the areas referred to by the Minister in the Answer in the House of Commons on the 18th May, to be included in the review of the classification of certain Local Government Areas.

RESOLVED—

- (a) **THAT the Minister of Health be asked to re-consider the question of the Borough of Hendon being re-zoned and classified as an evacuation area in view of the consideration which has been granted to the request of certain other areas, which in the opinion of this Committee are not more vulnerable than Hendon.**
- (b) **THAT the Borough Engineer be instructed to prepare plans and estimates for the provision of trenches in accordance with the suggestions contained in Board of Education Circular 1467, in suitable positions to serve as protective measures for children attending the schools specified in the report of the Director of Education, dated 18th May, 1939, for consideration by the Education Committee, and that such instruction be treated as a matter of urgency.**

EDUCATION ACT, 1936—EXEMPTIONS FOR BENEFICIAL EMPLOYMENT:

Pursuant to Item 11 in the Report of the Finance and General Purposes Sub-Committee, dated 9/5/39, it was **RESOLVED**—

THAT the following Special Sub-Committee be appointed to deal with applications for exemption from school attendance on the grounds of beneficial employment under the Education Act, 1936:—

Representatives of the Education Committee	{	Alderman J. J. Copestake, J.P.
		Councillor G. H. Hignett.
		Councillor W. H. N. Shakespeare, M.C., A.F.C., J.P.
		Councillor G. R. Richardson.
Representatives of the Juvenile Employment Sub-Committee	{	Councillor H. Connell, J.P.
		Councillor (Mrs.) F. E. Parvin.
		Councillor P. Lightfoot.
		Miss T. M. Hornsby.

MILK IN SCHOOLS SCHEME:

A letter was submitted from the Watling Association asking the Committee to reconsider their decision regarding the provision of milk for school children during the Midsummer Holidays.

RESOLVED—

THAT a reply be forwarded to the Association in the terms mentioned.

OTHER BUSINESS:

Recommendations from the Works and Fire Brigade Committee, regarding the use of certain school playgrounds for the purpose mentioned, and for the use of the old building at Edgware School for additional storage accommodation, were referred to the Chairman, **with power to act.**

SUMMER RECESS:

RESOLVED—

THAT the Education Committee at its rising do adjourn until the 26th September next, and that in the event of any matters of urgency arising during the interim they be referred to the Chairman and the Chairman of the appropriate Sub-Committee, with power to act.

Report (No. 1) of the Public Health and Medical Services Committee.

26th June, 1939.

COMMITTEE:

*Councillor T. J. Scott (*Chairman*).

Aldermen:

*W. R. Clemens, F.C.A.,

B. Flowers,

*W. M. Maughan, J.P.

Councillors:

F. W. Gilpin,

*P. Lightfoot,

*G. R. Richardson,

*G. H. Hignett,

*C. Pinkney,

H. P. Small,

*L. Hirshfield,

(Mrs.) M. Thomas.

Co-opted Members:

†Mrs. S. J. Bannister,
LL.A.,

†Mrs. W. M. Maughan,
Mrs. B. J. Monro, J.P.,

†The Rev. P. C. Howell.

* denotes Member present.

† Denotes Co-opted Member present on Parts I. and II.

Part I.—Medical Services.

1.—STATISTICAL INFORMATION:

Information as to Maternity and Child Welfare Services and attendances at Health Centres was submitted for the six weeks ended on the 17th June, 1939 (see statistical tables—Appendix to the report of the Finance and General Purposes Committee, page 9).

CHILD LIFE PROTECTION.

2.—NEW APPLICATION:

The Medical Officer reported the receipt of an application (Case No. 275) to undertake for reward the nursing and maintenance of a child under nine years of age.

RESOLVED TO RECOMMEND—That the maximum number of children under the age of nine years that may be kept at the premises in question be fixed at one.

3.—CHANGE OF ADDRESS:

Notification of change of address (Case No. 11) was reported, together with a report from the Medical Officer thereon.

RESOLVED TO RECOMMEND—That the maximum number of children under the age of nine years that may be kept at the new premises be fixed at one.

4.—CONVALESCENT TREATMENT:

The Medical Officer reported with regard to the cases of Mrs. W., Burnt Oak, and Mrs. L., Edgware.

RESOLVED TO RECOMMEND—That arrangements be made for the mother and child in each case to be sent away for three and four weeks' convalescent treatment respectively.

5.—ASSISTANT MEDICAL OFFICER:

It was mentioned that the applications to fill the vacancy occasioned by the resignation of Dr. S. L. Wright, reported at the meeting of the Council on the 19th instant, were due on the 10th July.

RESOLVED—That the Chairman of the Committee and the Medical Officer of Health be authorised to select applicants for interview at a Special Meeting of the Committee to be held on Friday, 14th July at 6 p.m.

HEALTH CENTRES.

6.—REPORT OF ROTA:

The following report was submitted:—

To the Public Health and Medical Services Committee.

We, the undersigned members, submit the following report of a visit made to the Central Hendon, Child's Hill, West Hendon, Watling and Mill Hill Health Centres on Tuesday, 6th June, 1939.

We inspected the interior of the permanent Health Centres and have recommended that certain work of cleansing and redecoration should be carried out during the month of August so as to interfere as little as possible with the normal activities of the Centres.

In addition we recommend the following:—

Central Hendon Health Centre.

Quadrangle between the wings of the building to be covered with tar macadam.

Watling Health Centre.

- (a) Existing wooden fencing to be replaced by iron railings.
- (b) Small lock-up cycle shed to be erected on North side for accommodation of six cycles.

Mill Hill Health Centre.

Eaves gutter with downpipe to be provided for perambulator shelter.

(Signed) T. J. SCOTT (Chairman).

VERONICA MAUGHAN.

The Borough Surveyor's estimate of the cost of the works suggested in the foregoing report is as follows:—

	£
Central Hendon	45
Child's Hill	16
West Hendon	15
Watling	183
Mill Hill	9

	£268

RESOLVED TO RECOMMEND—That the report of the Rota, together with the Borough Surveyor's estimate, be approved and adopted.

[Having considered the matter in its financial bearing, the Finance and General Purposes Committee concur in the proposal.]

7.—EDGWARE:

Reference was made to the question of the proposed Health Centre on the Broadfields Estate, and the matter has been referred to the Medical Officer for report.

8.—LIQUID MILK:

Communications were reported from the Milk Marketing Board and the Association of Municipal Corporations in reply to the representations received from the Council. (P.H. & M.S.C., 15/5/39—8).

The Milk Marketing Board forward a copy of a letter which had been addressed to the Council of the County Borough of Bournemouth in which they state that the question of allowing a rebate on milk supplied to local authorities in connection with their maternity and child welfare services has received the close attention of the Board for a considerable time, and that they have frequently intimated to the Government that they are willing to co-operate in a national scheme for the supply of milk to mothers and children at reduced rates. Apparently preliminary negotiations between the Government, distributors and the Board have already taken place, but it has not yet been possible to give any definite indication as to the outcome of such negotiations. **Noted.**

9.—MATERNAL MORTALITY:

With regard to Ministry of Health Circular No. 1705 (P.H. & M.S.C., 27/6/38—15) a communication was reported from the Hendon Division of the British Medical Association submitting the following names of four registered practitioners to serve on the Advisory Committee:—

Mr. Leonard Phillips, F.R.C.S.	(Obstetric Specialist and Gynaecological Surgeon).
Dr. E. ap I. Rosser	(Obstetrician to Redhill Hospital).
Drs. E. B. Morley and R. W. Cockshut	(General Practitioners).

As previously reported the Circular arises from a command report 5422, in which it was recommended that Local Supervising Authorities should, in consultation with the local medical profession, be empowered to take steps to ensure that the best local obstetric skill is made available in all cases in which midwives are required under the rules of the Central Midwives Board to call in a doctor.

A list of practitioners should be available in all cases in which a midwife is required to call in a registered medical practitioner in accordance with the provisions of Section 14 of the Midwives Act, 1918, and for this purpose an Advisory Committee (referred to above) consisting of the Medical Officer of Health, as Chairman, two general practitioners and two obstetric consultants should be formed after consultation with the representative organisations of local practitioners. The functions of this Committee would be to scrutinise the list and to make recommendations to the Authority to ensure a high standard of obstetric practice on the part of the practitioners included on the list. The list when compiled would be supplied to every midwife employed under Section 1 of the Midwives Act, 1936.

RESOLVED TO RECOMMEND—That the constitution of the proposed Advisory Committee be approved.

10.—REQUISITIONS:

Requisitions amounting to the sum of £347 6s. 4d. were submitted and approved.

**Part II.—Medical Services for approval by the
Hendon Education Committee.**

(See Education Minutes, Pages 894-895.)

Part III.—Public Health.

11.—STATISTICAL INFORMATION:

Information was submitted for the six weeks ended on the 17th June, 1939. (See Statistical Tables—Appendix to the report of the Finance and General Purposes Committee, page 9.)

12.—MILK AND DAIRIES (CONSOLIDATION) ACT, 1915, MILK AND DAIRIES (AMENDMENT) ACT, 1922, MILK AND DAIRIES ORDER, 1926:

An application was reported from the under-mentioned for registration as a retail purveyor of milk within the Borough:—

Name and Address of Applicant.	Source of Milk Supply.
Ellen Watson, 134, The Broadway, Cricklewood, N.W. 2—in respect of the premises named	Bladen Dairies Ltd., Millbourne St. Andrew, Dorset. (Milk in sealed cartons only.)

RESOLVED TO RECOMMEND—That the aforesaid applicant be registered accordingly.

13.—MILK (SPECIAL DESIGNATIONS) ORDER, 1936 AND 1938:

The following application for a Dealer's Licence under the above Order was reported:—

Name and Address.	Address at which milk will be sold.	Grade of milk to be sold.	Amount of fee.
Bury Farm Ltd., The Bury Farm, Edgware	The Bury Farm, Edgware	Pasteurised	5/-

RESOLVED TO RECOMMEND—That a licence be granted to Bury Farm Ltd., for the year 1939.

14.—STATUTORY NOTICES:

RESOLVED—That Statutory Notices be served in the following cases:—

Section 93, Public Health Act, 1936:—

- 26, Princes Park Avenue, Golders Green.
- 19, Lynton Avenue, Hendon.
- 49, Hillfield Avenue, Hendon.
- 36, Oak Grove, Cricklewood.

Sections 93 and 259, Public Health Act, 1936:—

Watercourse at rear of Eagle Lodge, Golders Green Road, Golders Green.

Section 75, Public Health Act, 1936:—

34, The Broadway, Cricklewood.

Section 112, Hendon Urban District Council Act, 1929:—

1201, Finchley Road, Golders Green.

REGISTRATION OF HAWKERS AND HAWKERS PREMISES.**15.—NEW APPLICATIONS:**

The following applications were reported:—

Hawkers:—

Joseph Gentry, 10, Parkhurst Road, Holloway, N., for the sale of fish.

Albert Perks, 53, Crest Road, Cricklewood, for the sale of vegetables.

(Food stores used by the aforementioned persons are not situate within the Borough of Hendon, their suitability as such has been verified by the respective Local Authorities.)

James Haslam, 134a, Burnt Oak Broadway, Edgware, for the sale of fish.

James King Warden, 195, Hale Drive, Mill Hill, for the sale of vegetables.

Leonard Wheatley, 152a, Burnt Oak Broadway, for the sale of fruit.

Hawkers Premises (Storage Accommodation):—

Premises.	Hawker.	Food.
Ventilated wooden structure in yard, 134, Burnt Oak Broadway, Edgware	Mr. James Haslam	Fish.
Lock-up Store, 71, Watling Avenue, Burnt Oak	Mr. Leonard Wheatley	Fruit.
Wooden Shed in yard, 53, Watling Avenue, Burnt Oak	Mr. James King Warden	Vegetables.

RESOLVED TO RECOMMEND—That the aforesaid persons and/or premises be registered with the Local Authority in accordance with the requirements of Section 71, Middlesex County Council (General Powers) Act, 1938.

16.—NO. 12, RAVENSHURST GARAGES, BABINGTON ROAD, AND 18, ANNESLEY AVENUE:

Having considered the reference from the Buildings and Town Planning Committee (22/5/39—6), it was

RESOLVED—That the Town Clerk report on the anomalies arising in connection with the registration of hawkers premises.

17.—NOS. 229 AND 235, CRICKLEWOOD LANE:

Demolition Orders under Section 11 of the Housing Act, 1936, were made by the Council on the 10th October last (P.H. & M.S.C., 19/9/38—21) and the houses are now available for demolition. In view of the proposed re-development of the site occupied by these and other unoccupied houses in Cricklewood Lane, in the same ownership, a request has been received for the demolition of Nos. 229 and 235 to be deferred pending a definite programme with regard to the site.

RESOLVED TO RECOMMEND—That the Council accede to the request.

18.—SMOKE ABATEMENT:

The following resolution adopted at the Annual Conference of the National Smoke Abatement Society held at Cardiff in December last, has been duly noted:—

"That the Conference of the National Smoke Abatement Society is of the opinion that in addition to all other action to promote smoke abatement, Local Authorities should ensure completely smokeless conditions in all premises under their control, thus setting a valuable example to the rest of the community and giving added force to their other smoke abatement work.

The Conference is also of the opinion that it would be of value to ascertain the progress already made in securing smokeless conditions in buildings under public control and requests the Executive Committee to make the necessary enquiries for that purpose and report thereon."

SHOPS ACT, 1934.

19.—SANITARY CONVENIENCES:

The Town Clerk submitted the following report as to the powers of the Council to require a minimum of two sanitary conveniences in connection with the erection of new shops. (P.H. & M.S.C., 15/5/39—14 (2)) :—

When plans of a building are submitted the Local Authority must reject them unless sufficient and satisfactory closet accommodation is provided for.

This will depend on the facts in each case and appeal will lie to the court of summary jurisdiction.

If the plans show that the building is likely to be used as a shop in which both sexes will be employed or in attendance, the Local Authority must reject the plans unless they show that sufficient and satisfactory separate closet accommodation for persons of each sex will be provided or they are satisfied that such provision may properly be dispensed with. Again an appeal lies to the court of summary jurisdiction.

It will be clear from the foregoing that the Council cannot insist on the provision of separate closet accommodation for persons of each sex in all cases but must consider each case on its merits. **Noted.**

20.—STAFF:

The Committee received a report from the Medical Officer arising out of the reference at the Meeting of the Council on the 19th instant.

It is the duty of the Sanitary Authority to enforce the provisions of the Shops Act, 1934, in relation to ventilation, temperature of shops, and with regard to sanitary conveniences, and this is undertaken by the Sanitary Inspectors on a reference from the Shops Inspectors.

Whilst it appears that the existing sanitary staff are coping with the work generally, it is anticipated that the Food and Drugs Act, 1938, which operates from the 1st October next will be administered by the Public Health Department. Taking this into account, and in view of work which it is necessary to undertake in connection with the Council's Air Raid Precautions Scheme and other recent legislation, the services of at least one additional Sanitary Inspector may be required at a later date. **Noted.**

ISOLATION HOSPITAL.

21.—REPORT OF ROTA:

The following report was submitted:—

To the Public Health and Medical Services Committee.

We, the undersigned members, submit the following report of a visit made to the above-named Hospital on Monday the 19th day of June, 1939.

- (1) We made a thorough inspection of the interior of the Hospital Buildings and recommend that certain necessary renovation work should be carried out.

- (2) In bedroom No. 19 (Administrative Block) it was observed that the paintwork had been affected by the percolation of moisture through the outside wall and it was agreed that the Borough Surveyor be asked to report on this matter.
- (3) It was also agreed that the Borough Surveyor's attention be drawn to the condition of the external paintwork, which was found to be very bad in many places, and to a crack in the brickwork of Ward No. 1.
- (4) The general working of the Hospital was found to be proceeding in a satisfactory manner.

(Signed) T. J. SCOTT.
LEO. HIRSHFIELD.
G. H. HIGNETT.

With regard to Item No. 1 the Borough Surveyor estimates the cost of these works at £125.

In connection with Bedroom No. 19 (Administration Block) it was reported that the external wall had previously been treated against damp penetration, and any damage to paintwork was caused by the drying out of the damp present in the wall at the time of treatment.

On the question of external decorations, the Borough Surveyor reported that provision had been made in the annual estimates to the extent of £200 and the work would be executed during the summer.

RESOLVED TO RECOMMEND—That the report of the Rota and the Borough Surveyor in relation thereto, be approved and adopted.

[Having considered the matter in its financial bearing, the Finance and General Purposes Committee concur in the proposal.]

22.—ADMINISTRATION BLOCK :

The Borough Surveyor reported with regard to the oak flooring to the corridor (Ground (Floor) on the north side of the Administration Block, and suggested that it should be replaced by a red quarry tile floor, similar to that in the kitchen and pantries, at an estimated cost of £28.

RESOLVED TO RECOMMEND—That the proposal be approved.

[Having considered the matter in its financial bearing, the Finance and General Purposes Committee concur in the proposal.]

23.—COAL STORE AND MESS ROOM :

The Borough Surveyor reported as to providing alternative accommodation to release the present coal store for additional storage purposes (P.H. & M.S.C., 15/5/39—16).

It was suggested that consideration should also be given to the provision of a mess room for the male staff, together with additional garage space for the van and the Medical Officer's car. A sketch plan of the proposals was submitted providing for the accommodation at the rear of the Laundry Block at an estimated cost of £375.

RESOLVED TO RECOMMEND—That the Borough Surveyor's proposals be approved and adopted.

[Having considered the matter in its financial bearing, the Finance and General Purposes Committee concur in the proposal.]

24.—SURGICAL UNIT:

The Borough Surveyor asked for authority to engage the services of a Quantity Surveyor for this work.

RESOLVED TO RECOMMEND—That Messrs. L. A. Francis & Sons be appointed at the scale of fees laid down by the Surveyor's Institution.

[Having considered the matter in its financial bearing, the Finance and General Purposes Committee concur in the proposal.]

25.—RE-DECORATIONS, ETC.:

With regard to re-decorations generally, including the Health Centres, the Committee are of opinion that each year, at their Meeting in November, a Sub-Committee should be appointed to consider as to the works required to be executed in order that provision may be made in the Annual Estimates, and they propose to act accordingly.

26.—LAND ADJOINING 1, GLOUCESTER GARDENS, GOLDERS GREEN:

Correspondence was reported with regard to the condition of the land referred to above, together with the observations of the Senior Sanitary Inspector. Instructions were given and the matter referred to the Town Clerk.

27.—WATERCOURSE PASSING THROUGH LAND BELONGING TO "GRAYSTANES," MARSH LANE, AT BOUNDARY OF SUNNYFIELDS ESTATE, MILL HILL:

The Town Clerk reported the receipt of a letter from John Laing & Son Ltd., stating that, without admitting liability, they were prepared to carry out certain works to the culvert to prevent flooding (P.H. & M.S.C., 15/5/39—12). **Noted.**

28.—FOULING OF FOOTPATHS BY DOGS:

The Committee re-considered this matter on the reference from the Highways Committee (15/5/39—13) and instructions were given thereon with a view to securing publicity in connection with the byelaw.

29.—BASEMENT BAKEHOUSE—448, FINCHLEY ROAD, CHILD'S HILL:

Section 54 of the Factories Act, 1937, prohibits the use as bakehouses of basement bakehouses other than those which were so used on the 30th July, 1937, and were certified as suitable by the Local Authority under the Factory and Workshop Act, 1901.

The Act of 1937 further provides that if a basement bakehouse is not used as a bakehouse for a period exceeding twelve months it must not be so used again; and, that every basement bakehouse in respect of which a certificate of suitability has been issued must be re-examined by the Local Authority in the year beginning on the 1st July, 1938, and in every fifth succeeding year. If as the result of the examination the Local Authority are not satisfied that the bakehouse is suitable for use as such as regards construction, height, light, ventilation, and any hygienic respect, they must notify the occupier in writing that the certificate will cease to have effect after a period, not being less than one month, specified in the notice. Alternatively they must give notice of continuance of the certificate. The occupier may appeal to a Court of Summary Jurisdiction against the decision of the Local Authority to terminate the certificate and may further appeal to Quarter Sessions.

With regard to the above premises, a certificate as to suitability for use of the bakehouse as such was granted by the Hendon Council on the 18th April, 1904, and baking has been done there continuously for many years.

RESOLVED TO RECOMMEND—That the Council give notice in writing that the certificate of suitability issued on the 18th April, 1904, shall continue to operate so long as the bakehouse may otherwise lawfully be used, but without prejudice to the power of the Council to revoke the certificate as the result of a subsequent examination under Section 54 (2) of the Factories Act, 1937.

30.—THE ROYAL INSTITUTE OF PUBLIC HEALTH:

The delegates appointed to the above Congress (P.H. & M.S.C., 9/1/37—23) submitted a report as to the proceedings, which was duly **noted**.

31.—REQUISITIONS:

The following requisitions were submitted and **approved**:—

	£	s.	d.
Public Health Department	20	1	6
Isolation Hospital	97	12	0

NOTE.—Report (No. 2) of the Public Health and Medical Services Committee to follow.

Report of the Highways Committee.

26th June, 1939.

COMMITTEE:

*Councillor A. W. Curton (*Chairman*).

Aldermen:

*J. J. Copestake, J.P.,

A. J. Reynolds, J.P.,

*F. C. Rice.

Councillors:

*E. Arter, M.C., M.I.A.E.,

*J. Griffiths,

*G. J. Pryke, F.I.A.C.,

*H. Connell, J.P.,

*A. A. Naar, M.B.E.,

A.M.I.S.E.,

*A. W. Greville,

*H. C. Potter, J.P., F.S.I.

*C. F. Windust.

(*Mayor*),

* denotes Member present.

1.—REQUISITIONS:

Requisitions amounting to £3,574 2s. 6d. were submitted and **approved**.

STREET TRADING.

2.—APPLICATION FOR LICENCE:

The Committee considered an application from Mr. F. E. Cox for a licence to sell confectionery from a stall in a stationary position on the south side of the carriageway of Brookfield Close at its junction with Brookfield Avenue, Mill Hill. Reports by the Borough Surveyor and the Commissioner of Police who do not favour the application were also considered.

RESOLVED TO RECOMMEND—That such application be disapproved.

PRIVATE STREET WORKS.

3.—OAKHAMPTON ROAD, MILL HILL:

Consideration was given to a report with regard to negotiations in connection with the making up of Oakhampton Road and the Committee have authorised the Borough Surveyor to complete his negotiations on the lines indicated.

4.—SERVICE ROAD, EDGWARE ROAD, HENDON:

The Borough Surveyor reported on a letter from the Varley Estates, Ltd., who desire to enter into an agreement with the Council in the usual standard form, relative to the making up and taking over of streets as public highways, in respect of the service road in front of a block of shops at The Hyde, Edgware Road. (Council, 19/6/39—Mayor's Recess Report—2 (E) (1)).

RESOLVED TO RECOMMEND—That authority be given to enter into an agreement in the standard form approved by the Council for the making up and taking over of the road in question, and that the Corporate Seal be affixed thereto.

5.—STOCKTON GARDENS, MILL HILL:

It was reported that the above road had been made up in accordance with the Council's standard agreement, and authority is required to dedicate such road as a public highway.

RESOLVED TO RECOMMEND—That Stockton Gardens be now dedicated as a public highway and the necessary notices duly posted.

6.—ROADS, FAIRVIEW ESTATE, EDGWARE:

The Committee considered a letter from the Edgware Ratepayers' Association urging the Council to take over without delay the roads on the above Estate which have been made up under an Agreement between the Council and the Sharon Development Co., Ltd. The Committee were informed that certain work is required to the roads before they can be regarded as completed in accordance with the Agreement, and that every effort is being made to induce the Company to expedite the necessary work, with a view to the subsequent dedication of the roads as public highways.

RESOLVED TO RECOMMEND—

- (i) **That the Association be informed accordingly.**
- (ii) **That the Borough Surveyor be requested to report on the matter to the next meeting.**

TRAFFIC.

7.—JUNCTION OF EDGWAREBURY LANE WITH EDGWARE WAY:

A copy of a letter was considered from the Edgware Ratepayers' Association addressed to the County Engineer and Surveyor asking for every endeavour to be made to expedite the construction of the Subway at the above junction, in view of the rapidly increasing number of children crossing the road on their way to and from school.

A subway at this junction was approved by the Council on the 4th July, 1938, on a report of the Highways Committee after a deputation had been received by the Parliamentary Secretary to the Ministry of Transport. The report was in the following terms:—

Junction of Edgware Way and Edgwarebury Lane.

In connection with the Council's application for traffic lights at this junction, the Deputation were informed that the Ministry had given the matter the most careful consideration and had called the Police into consultation. A census showed that the volume of traffic on Edgware Way was nearly nine times that of Edgwarebury Lane, which proved that the problem at this junction was primarily one of concern for the pedestrian crossing the Arterial Road. The installation of traffic lights at a junction where such traffic conditions exist had proved that the traffic was unduly delayed on the busier thoroughfare, whilst as an aid to pedestrians they are of little value as the change of light is so frequent and for so short a period that pedestrians are afforded but little opportunity to cross. The installation of lights at unsuitable places are considered to be conducive to accidents.

It was made abundantly clear that the installation of traffic lights would not be approved, but the Ministry are anxious to see a subway constructed. It is understood that this proposal has been before the Middlesex County Council but that no great interest appears to have been shown. For this reason, and the fact that the Town Council had pressed their application for lights, no progress has been made.

The Parliamentary Secretary intimated that Edgware Way being a County Road the normal grant of 60 per cent. would be available in connection with the construction of a Subway, and he expressed the view that if the Town Council would give the proposal their support he would again take the matter up with the Middlesex County Council with the hope of some measure of success.

RESOLVED TO RECOMMEND—

- (1) *That the Council with the full knowledge that the traffic lights will not be allowed do now approve the proposed subway, and*
 - (i) *that the Ministry of Transport be immediately informed accordingly, and*
 - (ii) *the County Council requested to give early consideration to the proposals of the Minister and to expedite the construction of the works;*
- (2) *That each of the Hendon Members of the Middlesex County Council be furnished with a copy of the foregoing report and the resolution of the Council,*

Consequent on the resolution of the Council of the 4th July, 1938, it was agreed that the cost of the proposed Subway should be borne as to 60 per cent. by the Ministry of Transport, 25 per cent. by the County Council and 15 per cent. by the Hendon Borough Council (5/12/38), and in January of this year it was understood that the County Engineer was proceeding with the preparation of the Scheme.

Considerable time will most probably elapse before the work on the Subway will be commenced, and the Committee upon reconsideration of the whole problem in the light of conditions which now prevail are of opinion that an adequate and more economical remedy would be provided by the immediate installation of traffic light signals at this point.

In these circumstances, the Committee

RESOLVED TO RECOMMEND—That the Minister be asked to re-consider the immediate installation of a system of traffic light signals at this junction and to receive a deputation from the Council on the matter.

8.—PEDESTRIAN CROSSING, ETC.—JUNCTION OF HAMPSTEAD WAY WITH FINCHLEY ROAD, GOLDERS GREEN:

The Borough Surveyor reported on a letter from the Hampstead Garden Suburb Residents' Association suggesting the erection of a "T" junction warning sign, the provision of a coloured pedestrian crossing and improved lighting at the junction of Hampstead Way with Finchley Road. An inspection has been made of the site and it would appear desirable to provide an additional lamp on the south side of Hampstead Way, about 30 yards from Finchley Road, but the Committee, however, are of opinion that no useful purpose would be served in approving the other suggestions of the Association.

RESOLVED TO RECOMMEND—That the Borough Surveyor be authorised to provide an additional lamp in Hampstead way in the position referred to, and that the Association be informed accordingly.

9.—JUNCTION OF DAWS LANE WITH WISE LANE, MILL HILL:

The Committee considered the question of the provision of painted lines on the carriageway at the above junction.

RESOLVED TO RECOMMEND—That the Borough Surveyor be authorised to arrange for the provision of painted lines at the junction in question.

10.—PEDESTRIAN CROSSING, SOUTH OF THE ORPHEUM THEATRE, FINCHLEY ROAD:

The Committee considered a letter from the Middlesex County Council intimating that they had been informed by the Minister of Transport that he feels that the above proposed pedestrian crossing is not justified in view of the traffic conditions which appear to be fully met by the existing crossings in this area. The Commissioner of Police is in agreement with the Minister's decision, and states that no accidents are known by the Police to have occurred in the locality. **Noted.**

11.—BARRIER RAILS, DAWS LANE, MILL HILL:

The Town Clerk reported the receipt of a letter from the Middlesex County Council approving the erection of barrier rails opposite the entrance to the Mill Hill Swimming Pool in Daws Lane at an estimated cost of £12, and stating that the County Council is prepared to defray a moiety of the balance of the cost after deducting the Ministry of Transport's grant, subject to the Town Council meeting the remainder of the cost, viz., £2 10s. 0d. (H.C., 9/1/39—13). **Noted.**

(The Finance and General Purposes Committee concurs in the proposal).

12.—BARRIER RAILS, GOLDERS GREEN CROSS ROADS:

The Committee received a deputation consisting of Messrs. Bernard, Mills, Quibell and Troup, on behalf of the Railings Protest Committee formed by certain shopkeepers of Golders Green. The deputation stated that the erection of the barrier rails at the Golders Green Cross Roads proved a serious menace to the traders affected, although the erection of the rails had not yet been completed. The majority of the traders in this area depended on trade with motorists. Clients and Customers had intimated that they were compelled to shop and trade elsewhere, with the result that a considerable depreciation in business had recently taken place. In the opinion of the traders the barrier rails constitute a danger to the public, in addition to being very unsightly. It was further pointed out that the value of rents and premiums paid for property would diminish.

A petition, containing 3,000 signatures, asking for the removal of the barrier rails, and a number of photographs taken of the conditions appertaining to the cross roads were submitted by the traders for the information of the Committee. The deputation, however, intimated that they would not object to the provision of barrier rails at the street corners.

The deputation thanked the Committee for receiving them and expressed the hope that the Council would arrange for the removal of the barrier rails.

The Town Clerk submitted a number of letters received, both for and against the removal of the rails, also details of accidents which had occurred at the cross roads during the last three years.

The Council (Hi.C., 4/4/38—11) approved the scheme of the Ministry of Transport for the installation of traffic light signals and the erection of pedestrian barrier rails at this junction, and on the 27th March (Hi.C., 6/3/39—13) the estimates were approved for submission to the Minister of Transport and the Middlesex County Council who are responsible financially for the scheme.

RESOLVED TO RECOMMEND—That, subject to the approval of the Minister of Transport and the Middlesex County Council the scheme of barrier rails be modified to provide for the termination of the rails at points in Colders Green Road, 90 feet from the junction of the cross roads, and at points 90 feet from the junction of the cross roads in a southerly direction in the Finchley Road.

13.—JUNCTION OF STATION ROAD WITH EDGWARE ROAD, HENDON:

The Borough Surveyor reported on a letter from the Borough of Hendon Labour Party (West Hendon Ward) with the following suggestions regarding the pedestrian crossings at the above junction:—

- (a) An all stop period of the lighting system.
- (b) Pedestrian operated signals, such as are already in existence in many parts of the Country.
- (c) The re-siting of the crossing at points a little further north and south of Station Road. (Hi.C., 27/6/38—9).

RESOLVED TO RECOMMEND—That representations be made to the Minister of Transport and the Commissioner of Police for the introduction in the cycle of operation of a period to provide for both sets of signals to show red lights.

PUBLIC LIGHTING.

14.—GREAT NORTH WAY, HENDON (FINCHLEY LANE TO PAGE STREET):

In connection with the reconstruction of the above section of Great North Way by the Middlesex County Council, the Borough Surveyor reported that it had become necessary to prepare a lighting system to conform to the new conditions.

The estimated capital cost of altering the positions of the existing lamps and providing the new services to the additional lamps is £1,064, and the annual charge for lighting and maintenance thereof will amount to £1,654.

Under the Trunk Roads Act, 1936, the Minister of Transport is empowered to make grants towards the cost of improved lighting systems on trunk roads and in these circumstances it is anticipated that grants of £532 and £827, being 50 per cent. of the capital and maintenance costs respectively, will be available.

RESOLVED TO RECOMMEND—That the scheme and estimates be approved and submitted to the Minister of Transport with an application for a grant under the Trunk Roads Act, 1936.

[Having considered the matter in its financial bearing, the Finance and General Purposes Committee concur in the proposal.]

15.—WEST HEATH ROAD, GOLDERS GREEN:

The Borough Surveyor reported on a letter from Mr. C. M. Young asking for improved lighting of the road. This road is included in the scheme for improved lighting shortly to be undertaken, and the Committee

RESOLVED TO RECOMMEND—That Mr. Young be informed accordingly.

TRAVELLING FACILITIES.

16.—OMNIBUSES, NORTH CIRCULAR ROAD:

The London Passenger Transport Board give notice, that commencing as from the 7th June, Route 18b now terminating at Finchley Memorial in peak hours on Mondays to Fridays and all day Saturdays, will be curtailed at Brent Station and the projection of the morning and evening journeys on Route 28 from Golders Green Station to Park Royal Station will be withdrawn. To compensate for these withdrawals the service on Route 112, Palmers Green and Kew Green, will be increased on weekdays from four buses an hour, to eight in peak hours on Mondays to Fridays and all day Saturdays, and six buses an hour on Mondays to Fridays in normal hours. **Noted.**

17.—STOPPING PLACES—FINCHLEY ROAD AND GOLDERS GREEN ROAD:

The Town Clerk reported the receipt of a letter from the Minister of Transport regarding the operation, for an experimental period of three months commencing on the 5th July, 1939, of stopping places for omnibuses and trolley buses in Finchley Road and Golders Green Road in the vicinity of the crossroads.

The Committee have no observations to offer on the proposal.

IMPROVEMENTS.

18.—FRITH LANE IMPROVEMENT—ACQUISITION OF LAND:

In connection with the above improvement the Borough Surveyor reported that it is necessary to acquire from the Borough of Finchley an area of land approximately 2,045 square yards in extent on the east side of Frith Lane. The District Valuer has negotiated terms with the Finchley Council and provisionally agreed the sale of land to Hendon at a sum of £500, the Hendon Council to pay the legal costs involved and to provide to the reasonable satisfaction of the Finchley Council, a fence along the new boundary (H.C., 17/4/39—17).

RESOLVED TO RECOMMEND—That the Council take a conveyance of the land in question on the above terms and that the Corporate Seal be affixed to any necessary documents in the matter.

[Having considered the matter in its financial bearing, the Finance and General Purposes Committee concur in the proposal.]

19.—EDGWAREBURY LANE IMPROVEMENT—(NORTH OF JOHN LAING & SONS LTD., ESTATE TO THE BARNET-ELSTREE ROAD):

The Borough Surveyor reported to the effect that the Minister of Transport, who has undertaken to make a grant of 33½ per cent. towards the cost of the improvement of Edgwarebury Lane north of the estate of John Laing & Sons Ltd., to the Barnet-Elstree Road, had suggested that the proposed line of road as provided by the Hendon Planning Scheme No. 1 should be amended as shown on the plan submitted, and the Minister is prepared to make the necessary Order under the Restriction of Ribbon Development Act, fixing the centre line of the road in accordance with the plan. The proposed amendment would improve the road from a traffic point of view, and the Committee

RESOLVED TO RECOMMEND—That the above proposal be approved and the Borough Surveyor authorised to negotiate with the principal land owners concerned, prior to making formal application to the Minister of Transport.

20.—EDGWAREBURY LANE IMPROVEMENT—(PARKSIDE DRIVE TO HARTLAND DRIVE):

It was reported that the above section of Edgwarebury Lane, had been widened and made up by John Laing & Sons Ltd., in accordance with the terms of their agreement with the Council, and it is now proposed to take the widened road over for the purposes of maintenance and repair.

RESOLVED TO RECOMMEND—That the Council take over the responsibility for the future maintenance and repair of the section of the road in question.

Amendment

Before detailed consideration of the motion, the Finance and General Purposes Committee Recommend—That the following words be added—

“subject to the execution of the intended agreement with John Laing & Sons Ltd.”

21.—FINCHLEY ROAD IMPROVEMENT—PORTSDOWN AVENUE TO CRICKLEWOOD LANE):

The Borough Surveyor reported that satisfactory progress is being maintained in connection with this improvement. It is anticipated that the work will be completed in about three weeks time. **Noted.**

22.—STATION ROAD, EDGWARE, BETWEEN MANOR PARK CRESCENT AND EDGWAREBURY LANE:

It was reported that the work of re-surfacing the above section of Station Road, Edgware, was completed on the 17th June, 1939. **Noted.**

23.—HENDON WOOD LANE IMPROVEMENT—JUNCTION WITH BARNET LANE:

The Town Clerk reported the receipt of a letter from the Middlesex County Council intimating that the revised scheme submitted by the Town Council on the lines suggested by the Minister of Transport, which is estimated to cost £1,530, including £10 in respect of legal costs is very desirable, but as the Barnet Road is a classified road within the County of Hertfordshire, it was decided that the Middlesex County Council's contribution would be on the basis originally agreed, viz., two-thirds of the balance after deducting the Ministry of Transport's grant (Hi.C., 6/3/39—23). **Noted.**

24.—SUNNY GARDENS ROAD, HENDON:

The Borough Surveyor submitted a plan of a suggested improvement of the highway whereby a footpath ten feet in width can be provided in Sunny Gardens Road between Florence Street and Church Walk. The proposal will necessitate the acquisition of a small piece of land (Hi.C., 6/2/39—32).

RESOLVED TO RECOMMEND—That the plan be approved and the Borough Surveyor be authorised to negotiate with the owner for the acquisition of the land in question.

25.—FORECOURTS, 42/4, VICTORIA ROAD, HENDON:

The Borough Surveyor reported on a letter from the Hendon Printing Works Ltd., offering to convey to the Council the forecourts of the above premises subject to the Council undertaking the paving, and bearing the necessary legal charges.

RESOLVED TO RECOMMEND—That the offer be accepted on the terms indicated and that the Corporate Seal be affixed to any necessary documents in the matter.

[Having considered the matter in its financial bearing, the Finance and General Purposes Committee concur in the proposal.]

26.—FORECOURTS, WATLING AVENUE:

The Committee have instructed the Borough Surveyor to report on the question of the forecourts of properties situate in Watling Avenue.

27.—DOLLIS COUNCIL JUNIOR AND INFANT SCHOOL:

The Committee considered a letter from Mr. F. H. Blackburn referred from the Education Committee (Works Sub-Committee 9/5/39—11) asking that steps be taken to ensure that there is a minimum of risk to children journeying between the School and the Devonshire Road side of Sanders Lane.

RESOLVED—That the Borough Surveyor be instructed to submit a report on the matter.

28.—WIRELESS RELAY SERVICE:

The Borough Surveyor reported on applications received from The Wireless Relay Services Ltd., and The Midland Radio Relay Services Ltd., for permission to erect wires over the highways of the Borough for the purpose of relaying Wireless Broadcast services. The Companies are prepared to enter into agreements and to pay royalties to the Council for the privilege. It has been the policy of the Council in the past to disapprove similar applications (H.C., 6/3/34—17).

RESOLVED TO RECOMMEND—That such applications be disapproved.

Report of the Estates, Parks and Allotments Committee.

26th June, 1939.

COMMITTEE:

*†Councillor F. J. Collins (*Chairman*).

Aldermen:

*†S. H. Egan, J.P.
(*Deputy Mayor*),

B. J. Monro,

*†R. A. B. Teare, M.B.E.

Councillors:

*†F. H. Bate,
*†T. K. Bridge,
*†E. J. Cox,

*†W. A. Hicks,
*†(Mrs.) F. E. Parvin,
T. Pugh,

*†J. H. Rodway,
*†W. H. N. Shakespeare,
M.C., A.F.C., J.P.

Co-opted Members:

†H. J. Ellner,
†T. W. Hammond,

†P. Knip,

†G. Thompson.

* denotes Member present.

† Denotes Member present at Allotments Committee.

1.—REQUISITIONS:

Requisitions amounting to £299 6s. 0d. were submitted and **approved**.

2.—HENDON PARK—CULTIVATION:

A letter was submitted conveying the congratulations of the Hendon Ratepayers' Association on the cultivation in Hendon Park. **Noted.**

3.—HENDON PARK—BOUNDARY FENCING:

The Borough Surveyor reported that the fencing forming the north-western boundary between the London Electric Railway and Hendon Park is in a very bad state of repair. The maintenance of the fence is the responsibility of the Council and the estimated cost of carrying out the necessary repairs is £45.

RESOLVED TO RECOMMEND—That the Borough Surveyor be authorised to carry out repairs to the fencing at an estimated cost of £45.

[Having considered the matter in its financial bearing, the Finance and General Purposes Committee concur in the proposal.]

4.—HENDON PARK—BANDSTAND:

A letter was received from the Hendon Peace Council asking for the use of the Bandstand in Hendon Park for a mass meeting in connection with the Annual Peace Week to be held in July.

RESOLVED TO RECOMMEND—That the Hendon Peace Council be informed that the Council are unable to grant such facilities.

5.—EDGWAREBURY PARK:

A letter was submitted from Mr. W. H. J. Cordle asking the Council to provide facilities for tennis in Edgwarebury Park. Provision of this character is contemplated by the approved five year programme of capital works and in anticipation of the further development of this Park an application is now before the Minister of Health for sanction to a loan for the erection of a pavilion and public conveniences.

RESOLVED TO RECOMMEND—

- (1) **That the necessary financial provision (£500) be made in the Estimates for 1940/41 for two tennis courts in Edgwarebury Park.**
- (2) **That Mr. W. H. J. Cordle be informed accordingly.**

[Having considered the matter in its financial bearing, the Finance and General Purposes Committee concur in the proposal.]

6.—MILL HILL PARK—BOWLING GREEN:

A letter was received from the Mill Hill Bowling Club asking the Council to re-open negotiations for the provision of a pavilion for the new bowling green.

The Committee have already given prolonged careful consideration to this matter and it was proposed (E.P. & A.C., 9/1/39—5) that in the event of the Council erecting a new pavilion the club should pay an annual rent of £100 for the use thereof (plus rates, if payable) and the Council would be responsible for external decorations. The Committee see no reason to depart from the terms indicated, and

RESOLVED TO RECOMMEND—That the Mill Hill Bowling Club be informed that the provision of a pavilion in connection with the new bowling greens can proceed on the terms already approved by the Council.

7.—MILL HILL PARK:

A letter was submitted from Mr. J. V. Sampson asking the Council to consider the question of season tickets for the use of the miniature golf course in Mill Hill Park.

RESOLVED TO RECOMMEND—That no action be taken in the matter at the present time.

8.—WATLING PARK—CONVENIENCE:

A letter was submitted from the Watling Association expressing appreciation of the new bowling green and asking the Council to consider the question of providing a convenience in the near vicinity.

In view of the fact that there is a convenience situate approximately 400 yards from the green, the Committee

RESOLVED TO RECOMMEND—That the Watling Association be informed that the Council regret they are unable to make any further provision of conveniences in Watling Park.

9.—YORK PARK—PUBLIC SHELTER:

The Committee considered a reference from the Public Health and Medical Services Committee (15/5/39—6) as to the advisability of providing a Public Shelter in York Park.

The Park is extensively used by children and nurses from the West Hendon Day Nursery and at the present time there is no provision for shelter during inclement weather.

RESOLVED TO RECOMMEND—That the erection of a shelter at a cost not to exceed £30 be approved.

[Having considered the matter in its financial bearing, the Finance and General Purposes Committee concur in the proposal.]

10.—SILK STREAM PARK:

A letter was received from Messrs. Biscoe & Stanton, on behalf of their clients, The London Diocesan Fund, asking whether the Council would be prepared to purchase approximately one-half acre of land situate at the rear of St. Alphege Church Hall and abutting upon two sides of Silk Stream Park.

RESOLVED TO RECOMMEND—That negotiations for the acquisition of the land as an addition to the Silk Stream Park be authorised.

11.—SUNNY HILL PARK—SALE OF REFRESHMENTS:

A letter was submitted from Messrs. Park Supplies, Harrow, withdrawing their tender for the right to sell refreshments in Sunny Hill Park. (Mayor's Easter Recess Report—Item No. 9).

Invitations for tenders for the right of the sale of refreshments in this Park have been issued on two occasions this year and the Committee now

RECOMMEND—That no further action be taken at present.

12.—COPTHALL PLAYING FIELDS:

An application was received from the Mill Hill Rugby Football Club asking whether the Council would be prepared to lease sufficient land in the north-western corner of the Cophall Playing Fields for use as a rugby pitch for the 1940/41 season, with dressing pavilion to be erected by the Council, the cost to be defrayed by an increased rent on a long term lease.

RESOLVED TO RECOMMEND—That the proposal be approved in principle and that negotiations be entered into with the Mill Hill Rugby Football Club.

(The Finance and General Purposes Committee note the above report).

13.—MONTROSE PLAYING FIELDS:

An application was received from Capt. A. G. Petrie, A.R.P. Warden, North Division, for permission to have the use of two cricket pitches and two tennis courts on the 23rd July from 2.30 p.m. to 7.30 p.m.

Permission is also sought for the erection of a marquee for the purpose of serving teas.

Teams from the three divisions of the Wardens' Organisation and from the Auxiliary Fire Service will take part in the games.

RESOLVED TO RECOMMEND—That facilities for the free use of the cricket pitches and tennis courts and for the erection of a marquee in Montrose Playing Field on Sunday the 23rd July from 2.30 p.m. to 7.30 p.m. be approved.

14.—BRENT PARK:

It was reported that nearly five thousand carp, roach and gudgeon had been conveyed to the lake in Brent Park in consequence of the filling in of the lake in the Exhibition grounds at Wembley. The Committee have expressed the appreciation of the Council for the action taken by the Borough Surveyor and the Deputy Borough Surveyor in the matter.

15.—ENTERTAINMENTS FOR CHILDREN:

The following arrangements were submitted for children's entertainments in five of the parks and open spaces during the schools' summer holidays. (E.P. & A.C., 15/5/39—9):—

Date.	Time.	Location.
31st July	3—4 p.m.	Hendon Park.
1st August	3—4 p.m.	Watling Park.
2nd August	11.30 a.m.—12.30 p.m.	Child's Hill Park.
3rd August	11.30 a.m.—12.30 p.m.	West Hendon Playing Fields.
8th August	3—4 p.m.	Clitterhouse Playing Fields.
9th August	11.30 a.m.—12.30 p.m.	Hendon Park.
10th August	11.30 a.m.—12.30 p.m.	Watling Park.
14th August	3—4 p.m.	Child's Hill Park.
15th August	3—4 p.m.	West Hendon Playing Fields.
16th August	11.30 a.m.—12.30 p.m.	Clitterhouse Playing Fields.
21st August	3—4 p.m.	Watling Park.
22nd August	3—4 p.m.	Child's Hill Park.
24th August	3—4 p.m.	West Hendon Playing Fields.
28th August	3—4 p.m.	Clitterhouse Playing Fields.
29th August	3—4 p.m.	Hendon Park.

The Committee have approved the arrangements and given instructions for the necessary action to be taken to bring the programme to the notice of the public.

16.—TENNIS COURT CHARGES:

A letter was received from the Hendon Ratepayers' Association regarding the charges for tennis before 9 a.m., Mondays to Fridays, and suggesting that the reduced charges at present in operation from 9 a.m. to 4 p.m., namely, 1/- per hour singles and 1/6d. per hour doubles, should be substituted for the present early morning charge of 2/- per hour for singles or doubles.

RESOLVED TO RECOMMEND—That the following charges for tennis be approved:—

Mondays to Fridays	7 a.m.—4 p.m.	1/- per hour singles. 1/6 per hour doubles.
Remaining Sessions (Saturdays, Sundays and Bank Holidays)		2/- per hour singles and doubles.

[Having considered the matter in its financial bearing, the Finance and General Purposes Committee concur in the proposal.]

17.—NATIONAL FITNESS COUNCIL:

The Borough Treasurer reported that an enquiry has recently been made by Mr. A. J. Skelton, the local representative of the London and Middlesex Area Committee of the National Fitness Council, as to whether the Council would consider the desirability of preparing a plan for the fuller use of the playing fields, particularly during the week. Reference was also made as to whether there would be any advantage in approaching owners of private sports grounds with a view to use by organisations who cannot secure accommodation either for financial or other reasons.

A survey has been made of the existing use of the Parks and Open Spaces, and it appears that the whole of the available pitches (comprising 20 cricket and 36 football) are fully booked for week-ends, and out of 9 parks, all except 2 are used to some extent during mid-week either for football or cricket. It is difficult to see how any extension of the use of the parks and open spaces could be permitted and at the same time maintain the various playing pitches in proper condition.

RESOLVED TO RECOMMEND—

- (1) **That Mr. Skelton be informed that in view of the extensive use made of the parks and open spaces the Council regret that they are unable to grant any additional facilities at the present time.**
- (2) **That Mr. Skelton be supplied with a list of private sports grounds in the district in order that he may communicate with the owners.**

18.—BULBS:

The following quotations were received for the supply of bulbs for the next planting season:—

	£	s.	d.
Cooper Taber & Co.	183	1	6
J. Carter Ltd.	178	10	0

Provision for this expenditure has been included in the Estimates for 1939/40.

RESOLVED TO RECOMMEND—That the lowest tender, namely, that of J. Carter Ltd., amounting to £178 10s. 0d. be accepted.

[Having considered the matter in its financial bearing, the Finance and General Purposes Committee concur in the proposal.]

ALLOTMENTS COMMITTEE.

19.—MONTROSE ALLOTMENTS:

A letter was submitted from the Hendon Federation of Allotment Societies asking the Council to provide a convenience on Plot 37 of the above allotments.

RESOLVED TO RECOMMEND—That a convenience be provided for Plot 37 on the Montrose Allotments at an estimated cost of £5.

(The Finance and General Purposes Committee concur in the proposal)

20.—HOSPITAL FIELD ALLOTMENTS:

A letter was received from the Hendon Federation of Allotment Societies asking for the water supply to be laid to the 24 plots of the Hospital Field Allotments on the east side of Hendon Way.

The plots in question are permanent allotments having an area of 1.2 acres.

RESOLVED TO RECOMMEND—That authority be given for a water supply to be connected to the Hospital Field Allotments on the east side of Hendon Way at an estimated cost of £20.

(The Finance and General Purposes Committee concur in the proposal).

21.—ALLOTMENT RENT ARREARS:

The Borough Treasurer reported that in accordance with the Committee's instructions (E.P. & A.C., 6/3/39—21) a notice to quit had been served upon the tenant of Plot 87 on the Child's Hill Allotments. The notice expired on the 29th April last and a request has now been received from the tenant for permission to retain his plot subject to payment of rent to the end of the present year.

RESOLVED TO RECOMMEND—That the tenant in question be placed on the waiting list.

Report of the Works and Fire Brigade Committee.

3rd July, 1939.

COMMITTEE:

*Councillor A. A. Naar, M.B.E. (*Chairman*).

Aldermen:

B. J. Monro.

*A. J. Reynolds, J.P.,

*F. C. Rice.

Councillors:

*F. J. Collins,

*A. W. Creville,

*J. H. Rodway,

*H. Cornell, J.P.,

*(Mrs.) F. E. Parvin,

*C. F. Windust.

A. W. Curton,

*H. G. Potter, J.P., F.S.I.

(Mayor),

* denotes Member present.

1.—REQUISITIONS:

The following requisitions were submitted and approved:—

	£	s.	d.
Works	1400	2	11
Fire Brigade	142	18	10

2.—STAFF INCREMENTS:

The Committee have received a report with regard to increments due according to scale to members of the fire brigade staff.

RESOLVED TO RECOMMEND—That such increments be granted as from the appropriate date.

[Having considered the matter in its financial bearing, the Finance and General Purposes Committee concur in the proposal.]

3.—STAFF SICKNESS:

A report was submitted with regard to the absence of ten members of the fire brigade staff.

In the case of Fireman W. A. Carey who suffered an injury to his knee whilst on duty it has been reported that he would be unable to do heavy work for at least six months.

RESOLVED TO RECOMMEND—That Fireman Carey be transferred to light duties as indicated by the Fire Superintendent and that a further report be submitted in six months time.

4.—RESIGNATION OF FIREMEN:

The resignations of Fireman M. D. Hughes, appointed to the Kingston-upon-Thames Fire Brigade, and temporary Fireman P. B. Nye were reported.

RESOLVED TO RECOMMEND—That the arrangements for filling the vacancies be referred to the Chairman (Councillor A. A. Naar, M.B.E.) and the Fire Superintendent with power to act.

5.—TEMPORARY FIREMAN:

The Fire Superintendent reported that Mr. W. F. Skinner had been appointed temporary fireman at Mill Hill Fire Station during the holiday period (W. & P.B.C., 24/4/39—5).

6.—INSPECTION OF FIRE APPLIANCES:

A recent inspection of fire appliances in the buildings enumerated in the report of the Fire Superintendent has been undertaken, when the appliances were found to be in order. **Noted.**

7.—FIRE PROTECTION:

The Fire Superintendent reported that in response to many requests he had inspected various factories in the district and given advice on fire protection. **Noted.**

8.—FACTORIES ACT, 1937:

Inspections have been carried out under the above Act at the following premises:—

First National Cleaners Ltd., Brent Street, N.W. 4.

Warden & Co. Ltd., Church Road, N.W. 4.

Eugene Ltd., The Broadway, N.W. 9.

Sordoviso Switchgear Ltd., 220, The Vale, N.W. 11.

RESOLVED TO RECOMMEND—That certificates as to means of escape in case of fire be approved in respect of such premises.

9.—FIRE DRILL INSTRUCTION:

It was reported that fire drill instruction has been given by the Brigade at the following premises:—

John Groom's Crippleage.

Boosey & Hawkes Ltd., Deansbrook Road.

F. Tucker & Co., Ltd.

Everett, Edgumbe & Co., Ltd.

North Middlesex Gas Co.

Franco-Signs Ltd.

10.—FIRE HYDRANTS:

Since the last meeting of the Committee a fire hydrant has been fixed in Road F. Woodgrange Estate, Edgware. **Noted.**

11.—PETROLEUM STORAGE LICENCES:

The following applications for licences to store petroleum have been received:—

Sir Robert McAlpine & Sons (London) Ltd., 50, Pall Mall, London, S. W. 1	To store 40 gallons in a galvanised bin in field off Edgware Way, Edgware.
Girdlestone & Co., 23, Davies Street, London, S. W. 1	To store 10 gallons of petroleum mixtures in drums at North Road, Burnt Oak.
The United Yeast Co., Ltd., 27/29, Church Road, Hendon, N.W. 4	To store 60 gallons in cans in an under- ground vault in Ravenshurst Garage, Babington Road, N.W. 4.

RESOLVED TO RECOMMEND—That the applications be approved and the necessary licences issued in due course.

12.—PETROLEUM AND CARBIDE LICENCES:

An application has been received from the London Passenger Transport Board for alteration of their Petroleum Licence (No. 147) in respect of their premises at Station Road, Edgware, from 7,000 gallons to 3,300 gallons and for the alteration of their Carbide Licence (No. 4) from 1 ton to 4 tons.

RESOLVED TO RECOMMEND—That authority be given for the necessary amendments to be made to the licences.

13.—LOUD SPEAKERS—CENTRAL FIRE STATION:

Owing to the excessive noise made by trailer pumps working in the drill yard at the Central Station it has been found very difficult to hear instructions given for fire and ambulance calls. Experiments have been carried out with Phileo loudspeakers which have proved successful and the Committee

RECOMMEND—That a set of loudspeakers be purchased for the Central Station at a cost of £10 10s. 0d.

[Having considered the matter in its financial bearing, the Finance and General Purposes Committee concur in the proposal.]

14.—FIRE AND AMBULANCE CALLS:

The following is a statement of fire and ambulance calls received during the month of May.

Fire Calls.		Ambulance Calls.	
Fire Calls	17	Private	113
Malicious False Alarms	4	Private for Finchley	2
Inspections	2	Private by Harrow for Hendon	1
		Private for Council's Midwives	5
		Accidents	70
		Malicious Calls	1
		Not required, etc.	24
	23		216

15.—ROTA:

A report was submitted by Councillors (Mrs.) Parvin and Windust upon their visit to the Central and Mill Hill Fire Stations when everything was found to be satisfactory. **Noted.**

16.—THE BRITISH FIRE SERVICES COUNCIL—CONFERENCE:

An invitation was received from the above Council to appoint representatives to attend the Third British Fire Week Conference to be held at Blackpool from the 11th to the 15th September, 1939.

RESOLVED TO RECOMMEND—That Councillor H. Connell and the Fire Superintendent be appointed to attend the Conference.

[Having considered the matter in its financial bearing, the Finance and General Purposes Committee concur in the proposal.]

AUXILIARY FIRE SERVICE.

17.—PERMANENT STAFF—APPOINTMENT:

It has been reported that the amount of auxiliary fire service equipment now warrants the appointment of a storekeeper and the Committee

RECOMMEND—That application be made to the Home Office for consent to the appointment of an additional fireman as storekeeper for the auxiliary fire service equipment and appliances.

(The Finance and General Purposes Committee concur in the proposal.)

18.—OFFICERS TRAINING CLASS:

It was reported that temporary officers appointed in March last have completed a special course of instruction and are now assisting in the training of recruits. **Noted.**

19.—APPOINTMENT OF ADDITIONAL OFFICERS:

In view of the increasing numbers in personnel and also to put the organisation on an emergency basis the Fire Superintendent recommended the following promotions and appointments:—

Senior Divisional Officer—Section Officer H. Bevir.

Divisional Officer (South Division)—Section Officer D. A. Davis.

Divisional Officer (North Division)—Section Officer J. J. Ellis.

Section Officers—Sub-Officer H. B. Goss.

” ” A. C. Giles.

” ” H. Harris.

” ” N. A. Everett.

Sub-Officers—Auxiliary Fireman A. Snowman.

” ” I. H. Shaw.

” ” T. P. Goodfellow.

” ” E. W. Cater.

” ” J. S. Goff.

” ” J. J. Benton.

” ” A. V. Whittingham.

” ” H. W. Kitchener.

” ” T. W. Brock.

” ” R. C. G. Leslie.

” ” A. J. Devlin.

” ” K. Russell.

” ” W. D. Capjon.

” ” M. Flatto.

The Fire Superintendent also reported that the following Section and Sub-Officers who were appointed temporarily in March last have given every satisfaction and recommends the confirmation of their appointments:—

Section Officers:—

Mr. F. Hillier,
Mr. S. Laughlin,

Mr. H. W. Peacock,
Mr. R. Potter.

Sub-Officers:—

Mr. R. H. Biggs,
Mr. C. H. Davis,
Mr. A. Foskett,
Mr. W. Garvan,
Mr. R. Jordan,
Mr. H. S. Jupp,
Mr. L. M. Jeremy,
Mr. E. Lambourne,

Mr. H. S. Lipkin,
Mr. A. H. Livsey,
Mr. H. F. Mertens,
Mr. D. Naar,
Mr. D. G. Rye,
Mr. S. W. Sexton,
Mr. W. J. Stewart,
Mr. H. R. Tyler.

RESOLVED TO RECOMMEND—That the above promotions and appointments be confirmed.

20.—RESIGNATIONS OF AUXILIARY FIREMEN:

The Fire Superintendent reported that Section Officer W. Cannon and Sub-Officer E. S. Davis, have tendered their resignations, the former owing to business reasons and the latter having rejoined the Air Force Reserve. **Noted.**

21.—ACCIDENT TO AUXILIARY FIREMAN:

It was reported that during training Auxiliary Fireman H. Pearce fractured a bone in his right hand and is, at present, unable to follow his employment. **Noted.**

22.—INSURANCES:

Pursuant to the reference from the Finance and General Purposes Committee (F. & G.P.C., 12/6/39—33) the Committee have given consideration to the question of the acceptance of two volunteers having regard to the observations of the Council's Insurance Company in the light of certain qualifications made by the volunteer's Medical Advisers.

In view of the whole of the circumstances, the Committee

RESOLVED TO RECOMMEND—

- (1) **That the volunteers in question be thanked for the offer of their services and informed that the Council regret that they are unable to accept enrolment as Auxiliary Firemen.**
- (2) **That in the event of any further cases presenting medical certificates with qualifications similar action be taken.**

23.—TRAINING STATISTICS:

The following statistics were submitted and duly **noted:—**

No. of Firemen completed training	211
No. of Firemen in training	342
								553
						TOTAL
No. of Drivers in training	30
No. of Messengers in training	9
No. of Telephonists in training	42

24.—TRAINING MOTOR:

A report was submitted on the advisability of purchasing an open truck for the purpose of training the Auxiliary Fire Service drivers with heavy vehicles towing trailer pumps.

RESOLVED TO RECOMMEND—That subject to the approval of the Home Office a second-hand motor truck be purchased for training the Auxiliary Fire Service drivers.

(The Finance and General Purposes Committee concur in the proposal).

25.—TRAILER PUMPS:

It was reported that a further consignment of Home Office Trailer Pumps consisting of three large and sixteen light, have been received and further storage accommodation was needed.

Temporary accommodation for certain auxiliary fire equipment has already been provided in the old school buildings at Edgware and it is suggested that further rooms in the same building can with any necessary structural alterations be adapted to provide additional accommodation for the fire appliances.

RESOLVED TO RECOMMEND—That, subject to the approval of the Education Committee, the Borough Surveyor be instructed to carry out the necessary works to adapt further rooms in the old Edgware School as additional accommodation for the storage of auxiliary fire equipment and appliances.

26.—TRAINING FACILITIES:

The Fire Superintendent reported that he had received requests from the auxiliary firemen, who have completed their course of training, for the provision of divisional headquarters where they can meet for training and recreational purposes.

It is suggested that a wooden constructed building in Bunns Lane should be used to serve the Northern Division and St. Judes' Church Hall to serve the Southern Division. In addition, the Fire Superintendent desires the use of the school playgrounds mentioned hereunder for drill purposes and the provision of lock-ups for storing training equipment at these schools:—

Bell Lane.
Deansbrook.
Child's Way.
Edgware.

RESOLVED TO RECOMMEND—

- (1) That the Fire Superintendent be authorised to negotiate with a view to obtaining the use of the buildings referred to for divisional headquarters for training and recreational facilities.
- (2) That, subject to the approval of the Education Committee, the above-mentioned school playgrounds be used for drill purposes and lock-ups for the storage of training equipment be provided.

Amendment

Before detailed consideration of the motion, the Finance and General Purposes Committee Recommend—That the following be added:—

"(3) That any proposals involving expenditure under recommendations (1) and (2) be submitted for the approval of the Home Office."

27.—STANDPIPE SHAFTS:

The Fire Superintendent reported upon the necessity of purchasing 30 additional standpipe shafts for use in connection with the trailer pumps recently received from the Home Office.

RESOLVED TO RECOMMEND—That 30 standpipe shafts be purchased at an estimated cost of £45.

(The Finance and General Purposes Committee concur in the proposal).

28.—LADDERS:

At the request of the Fire Superintendent an Inspector of H.M. Office of Works had examined defects in ladders issued to this Authority and five ladders were found to be unfit for use. **Noted.**

29.—FIRE HOSE:

It was reported that the Home Office had supplied 3,700 feet of hose, to replace the hose showing signs of wear, together with 20 pairs of instantaneous couplings. **Noted.**

30.—SWIMMING POOLS—CHARGES FOR ADMISSION:

The Committee received a deputation consisting of Miss D. P. Dangertfield, Mrs. E. Payne, Mr. J. W. Cooper and Major G. W. Wills from the Youth Organisations Committee (W. & F.B.C., 22/5/39—24) on the question of the charges for admission to swimming pools for affiliated organisations.

The deputation pointed out that there is a membership of 6,000, of whom approximately one-third are between the ages of 14-18 years. During the last nine years there had been only 300 entrants to the annual swimming gala. Members were now availing themselves of the cheaper facilities in adjoining Boroughs and it was contended that in the event of the charges being reduced in the Hendon district attendances at the swimming pools would increase.

RESOLVED TO RECOMMEND—That as an experiment for the current season (and then subject to review) the Council approve the issue of twelve tickets at a cost of 2/- available from Mondays to Fridays, such tickets to be issued through the responsible leaders of the Youth Organisations Committee.

[Having considered the matter in its financial bearing, the Finance and General Purposes Committee concur in the proposal.]

31.—SWIMMING AND PHYSICAL TRAINING INSTRUCTION:

A letter was received from the National Fitness Committee (London & Middlesex) drawing attention to the action taken by the London County Council in providing instructors in physical training and swimming at three of their lidos as a result of a successful experiment last year. Six full-time instructors, one man and one woman at each lido, are engaged at £5 per week each for a period of 13 weeks and the National Fitness Committee express the hope that the Council will give sympathetic consideration to the scheme with a view to putting it into operation.

RESOLVED TO RECOMMEND—That the National Fitness Committee be informed that the Council regret they are unable to take any action in the matter at the present time.

32.—TRADE REFUSE:

A letter was received from the Golders Green and District Chamber of Commerce regarding the Council's decision on the question of the collection of trade refuse (W. & F.B.C., 24/4/39—19) and suggesting a deputation be received.

RESOLVED—That a deputation from the Golders Green and District Chamber of Commerce be received at the next meeting.

33.—REFUSE COLLECTING VEHICLES:

It was reported that Pagefield No. 5 (Reg. No. M.T. 955) which was purchased during the Financial Year 1928/29 is now due for replacement.

In view of the extensive development which has taken place in recent years it is desirable to adopt the single unit system in the areas within reasonable distance from the Refuse Disposal Works and to continue the Pagefield system in the northern part of the Borough where mileage is an important factor. It is accordingly suggested that Pagefield No. 5 be replaced by three Pagefield "Prodigy" vehicles and the Committee have considered a quotation from Walker Bros. (Wigan) Ltd., amounting to £2,217. This firm is prepared to make an allowance of £50 for the old vehicle resulting in a nett tender of £2,167.

RESOLVED TO RECOMMEND—

- (1) **That the arrangements for the collection of refuse outlined above, be approved.**
- (2) **That the tender of Walker Bros. (Wigan) Ltd. for three Pagefield "Prodigy" vehicles amounting to £2,167 be accepted.**
- (3) **That the Corporate Seal be affixed to any necessary documents.**

[Having considered the matter in its financial bearing, the Finance and General Purposes Committee concur in the proposal.]

34.—SURFACE WATER SEWER—ROOKERY CLOSE:

A letter was received from the Grand Union Canal Company asking the Council to contribute towards the cost of filling in the low lying land at the rear of houses in Rookery Close (W. & F.B.C., 21/11/38—30). It will be remembered that in consequence of tipping operations on this land the outlet of the surface water sewer was impeded with the consequent flooding of the surrounding land.

The outlet to the surface water sewer from Rookery Close was eventually extended by the Company to the Silk Stream and the Council agreed to contribute half the cost, up to a maximum of £80, in respect of this particular work.

RESOLVED TO RECOMMEND—That the Grand Union Canal Company be informed that the Council regret they are unable to accede to their request for a contribution towards the cost of filling in the low lying land.

35.—EAST MIDDLESEX MAIN DRAINAGE—DOLLIS BROOK—SEWER:

In connection with the East Middlesex Main Sewerage Scheme it will be necessary for a section of a sewer to be laid through part of the Riverside Walk at Woodside Park and at the rear of the houses in Chanetonbury Way.

The sewer will be constructed by the Middlesex County Council for which purpose the required easement is necessary in pursuance of the Middlesex County Council (Sewerage) Act, 1938.

RESOLVED TO RECOMMEND—That the Chief Officers be authorised to negotiate terms for the grant of the necessary easement to the County Council and that the Corporate Seal be affixed to any necessary documents.

[Having considered the matter in its financial bearing, the Finance and General Purposes Committee concur in the proposal.]

36.—DRAINAGE OF LAND AT ELSTREE:

It was reported that certain areas in the Urban District of Harrow situate to the west of Brookley Hill between Wood Lane and Elstree cross-roads drain into the Council's sewer which terminates at the head of the Silk Valley Low Level Sewer at Newlands Corner.

RESOLVED TO RECOMMEND—That the Chief Officers be authorised to enter into negotiations with the Harrow Council for the execution of a drainage agreement.

(The Finance and General Purposes Committee concur in the proposal.)

37.—EMPTYING OF CESSPOOLS:

In connection with the services for emptying cesspools it is suggested that any emptying in excess of eight times per annum should be charged for at the appropriate rates based upon capacity of the pools and other considerations in relation to the costs of the work.

RESOLVED TO RECOMMEND—That a charge be made for emptying a cesspool in excess of eight times per annum.

[Having considered the matter in its financial bearing, the Finance and General Purposes Committee concur in the proposal and have instructed the Borough Treasurer regarding the writing off of certain outstanding charges].

38.—TOWN HALL—RECORDS STORE:

In connection with the erection of a records store at the rear of the Town Hall (F. & G.P.C., 20/2/39—27) an amended site plan was submitted consequent on the provision of the site for an air raid precautions multi-purpose building and for the future extension of the Town Hall. The service road has been retained and the lay-out so arranged that it will be possible to construct an additional outlet from the rear of the Town Hall by means of a connection to the road in Hendon Grove.

RESOLVED TO RECOMMEND—

- (1) That the general lay-out plan be approved.
- (2) That Messrs. L. A. Francis & Sons be appointed to prepare the bill of quantities at fees in accordance with the scale of the Surveyors' Institute.

[Having considered the matter in its financial bearing, the Finance and General Purposes Committee concur in the proposal.]

39.—MORTUARY AT REAR OF TOWN HALL:

In order to insure that the "Kelvinator" equipment in the public mortuary is periodically inspected and kept in running order it is necessary to enter into an annual agreement with Kelvinator Ltd.

RESOLVED TO RECOMMEND—That an agreement for maintenance of the equipment at an annual charge of £5 be entered into with Kelvinator Ltd.

(The Finance and General Purposes Committee concur in the proposal).

40.—PUBLIC WORKS, ROAD AND TRANSPORT CONGRESS AND EXHIBITION:

An invitation was received to appoint delegates to attend the above Congress and Exhibition to be held at the Royal Agricultural Hall from the 13th—18th November, 1939.

RESOLVED TO RECOMMEND—That no action be taken in the matter.

41.—REPAIR TO PROPERTY:

Since the last meeting of the Committee, 145 requisitions have been dealt with and other works enumerated in the report of the Borough Surveyor are nearing completion.

Noted.

Report of the Libraries and Local Pensions Committee.

3rd July, 1939.

COMMITTEE:

*Councillor P. Lightfoot (*Chairman*).

Aldermen:

*W. M. Maughan, J.P.,

*R. A. B. Teare, M.B.E.

Councillors:

*T. K. Bridge,

G. Pinkney,

*G. R. Richardson,

*E. J. Cox,

*G. J. Pryke, F.I.A.C.,

T. J. Scott,

*F. W. Gilpin,

A.M.I.S.E.,

(Mrs.) M. Thomas.

* denotes Member present.

Part I.—Old Age Pensions.

1.—CLAIMS, ETC.:

The Committee considered seventeen claims and two questions. The details of each case and the Committee's decision thereon are recorded in the Local Pension Minute Book.

Part II.—Libraries.

2.—REQUISITIONS:

Requisitions amounting to £628 13s. 10d. were submitted and approved.

3.—SCHOOL LIBRARIES JOINT SUB-COMMITTEE:

The following report was submitted:—

3rd July, 1939.

SUB-COMMITTEE:

Council Representatives:—

Councillor T. J. Scott (*Chairman*),

*Alderman R. A. B. Teare, M.B.E.,

Councillor G. R. Richardson.

Education Committee Representatives:—

*Councillor P. Lightfoot,

*Mrs. S. J. Bannister, L.L.A.,

*The Rev. I. Livingstone.

Head Teachers' Representatives:—

*Miss A. M. Willis,

Miss A. M. Wharton,

Mr. A. J. Albon,

*Mr. S. A. Grassam.

* denotes Member present.

In the absence of the Chairman, Alderman R. A. B. Teare, M.B.E., was elected to the Chair.

(a) STATISTICS:

During the Easter Holidays 14 Schools were visited and the stock of books overhauled. 145 worn out and imperfect books were withdrawn as unfit for further circulation, and 539 withdrawn for binding. 1,005 books were repaired.

A statement was submitted showing the number of pupils over 8 years of age and the number of volumes at present in each of the School Libraries. A summary of the position is as follows:—

Number of pupils
over 8 years of age.
9,145

Number of books
in stock.
14,745

Noted.

(b) ADDITIONS TO STOCK:

The Chief Librarian suggested the purchase of 365 volumes at an estimated cost of £63 17s. 6d. for distribution to the following schools:—

Clitterhouse	100
Colindale	130
Deansbrook	15
Garden Suburb	25
Goldbeaters Junior	25
St. John's C.E.	10
Wessex Gardens (Boys)	50
Woodcroft Junior	10
	365

The Sub-Committee

RECOMMEND—That, subject to the approval of the Education Committee, the suggestion of the Chief Librarian be approved and adopted.

(c) REPLACEMENTS:

On the report of the Chief Librarian, the Sub-Committee

RECOMMEND—That authority be given for the purchase of 120 standard books at an estimated cost of £21, subject to the approval of the Education Committee.

(d) YEAR'S WORK:

The School Libraries have circulated 167,012 books during the year.

The number of volumes in stock on March 31st was 15,709, 1,722 volumes having been added during the year and 1,648 withdrawn. 4,692 were repaired by the staff and 2,213 rebound. **Noted.**

(e) HANDICRAFTS COLLECTION:

This collection has been used steadily throughout the year, especially for books on physical training, needlework, art, and paper cutting. The stock now numbers 337 and 1,710 books have been issued. **Noted.**

(f) ILLUSTRATIONS COLLECTION:

It was reported that 11,470 items were in the Illustrations Collection and 2,167 issues were made during the year. The requests have been varied and interesting. **Noted.**

(g) NEW CENTRE:

A new Centre has been opened at Frith Manor School, and Edgware School Library has been divided into a Senior and a Junior Section, owing to the re-organisation of the School. **Noted.**

RESOLVED TO RECOMMEND—That the report of the Joint Sub-Committee be approved and adopted.

4.—BOOK SELECTION SUB-COMMITTEE:

The following report was submitted:

3rd July, 1939.

SUB-COMMITTEE:

***Councillor P. Lightfoot (Chairman).**

Alderman:

***R. A. B. Teare, M.B.E.**

Councillors:

(Mrs.) M. Thomas,

***G. R. Richardson,**

T. J. Scott.

** denotes Member present.*

PURCHASE OF BOOKS—ADDITIONS TO STOCK:

The Sub-Committee considered lists comprising 169 recent and standard books suggested for addition to the stock at the Central Library at an estimated cost of £53, 191 volumes for addition to the stock of the Golders Green Branch Library at an estimated cost of £53, and 159 volumes at an estimated cost of £47 for addition to the stock of the Mill Hill Branch Library.

The Sub-Committee

RECOMMEND—That the Chief Librarian be authorised to purchase the books included in the lists submitted.

RESOLVED TO RECOMMEND—That the report of the Sub-Committee be approved and adopted.

5.—STATISTICS:

The Chief Librarian submitted his statistical statement for the month of May, details of which appear in the appendix to the report of the Finance and General Purposes Committee.

CONFERENCES.

6.—ASSOCIATION OF SPECIAL LIBRARIES AND INFORMATION BUREAUX:

The Chief Librarian reported that notice had been received of the above Conference to be held at Nottingham University College from 15th—18th September, 1939. This Conference is usually attended by representatives of University and Special Libraries Research Laboratories, and similar organisations, with which the Hendon Libraries have established many contacts through membership of the Association. Delegates are housed in the University, at a cost including the Conference fee, of £3.

RESOLVED TO RECOMMEND—That Mr. C. C. Poole (Sub-Librarian) be appointed as the Council's delegate to the Conference.

[Having considered the matter in its financial bearing, the Finance and General Purposes Committee concur in the proposal.]

7.—LIBRARY ASSOCIATION:

A report was submitted and duly noted with regard to the proceedings at the recent Conference of the Library Association to which the Chairman of the Committee (Councillor P. Lightfoot) and the Chief Librarian were appointed as delegates. (Li.C., 16/1/39—7).

8.—MILITIAMEN—LIBRARY SERVICE:

It was reported that the Army Education Officer at Mill Hill Barracks had enquired whether the 150 Militiamen to be stationed at the barracks, some of whom would be continuing educational studies, would be permitted to enrol as members of the Hendon Libraries, or if the requisite books would be supplied to and distributed in the barracks.

As the enquiry was urgent the Officer had been informed forthwith that it would be preferable for those requiring books for study or recreation to enrol as members by signing the membership card, with the recommendation of the Commanding Officer. The Militiamen would be regarded as temporary employees within the Borough and the Commanding Officer's recommendation would not entail any financial responsibility. Handbooks of information containing rules, etc., have been forwarded to the Education Officer.

RESOLVED TO RECOMMEND—That the action taken be approved.

9.—SOUTH EASTERN REGIONAL LIBRARY SYSTEM:

A copy of the fifth Annual Report of the Executive Committee for the year 1938/39 was circulated to the Members of the Committee and duly noted.

LECTURES, ETC.**10.—UNIVERSITY EXTENSION:**

The Chief Librarian reported that the London University had arranged for Mr. Eric Gillett to give a course of six lectures at the Central Library entitled "What We are Reading Now," on Wednesdays at 8 p.m., commencing on October 18th. **Noted.**

11.—PROGRAMME—OCTOBER – DECEMBER, 1939:

A proposed programme was submitted of Public Lectures and Recitals (Adults) to be held at Mill Hill Branch Library on Wednesdays at 8 p.m. and at the same time on Thursdays at the Central Library. Proposals were also submitted in connection with talks to children at Mill Hill on Wednesdays, and Central Hendon and Golders Green on Thursdays at 6 p.m.

RESOLVED TO RECOMMEND—That the programme be approved, and that any necessary arrangements in connection therewith be made by the Chief Librarian.

PERIODICALS—REVISION OF LIST.**12.—TRIAL PERIOD:**

It was decided (Li.C., 21/11/38—17) that the under-mentioned periodicals be taken for six months' trial period to test their demand:—

Central Library	Nursery World (Weekly, 3d.).
Golders Green Branch	A.R.P. News (Monthly, 6d.).

RESOLVED TO RECOMMEND—That the purchase of Nursery World be discontinued, and that A.R.P. News be continued for a further period of six months, to include the Central Library and Mill Hill Branch.

13.—READERS' SUGGESTIONS:

The Committee considered suggestions from readers and on the report of the Chief Librarian, it was

RESOLVED TO RECOMMEND—That the following periodicals be added to the lists:—

Central Library:—

Picture Post (Weekly, 3d.).

Golders Green Branch:—

Picture Post (Weekly, 3d.).

Sight and Sound (Quarterly, 6d.).

Mill Hill Branch:—

Motor Cycling (Weekly, 3d.).

Readers Digest (Monthly, 1/-).

14.—LIBRARIAN'S SUGGESTIONS:

RESOLVED TO RECOMMEND—That the following suggestions for the purchase of periodicals be approved:—

Central Library:—

John O'London (Weekly, 2d.).

Golders Green Branch:—

Adult Education (Quarterly, 1/-).
Das Neue Tage-Buch (Weekly, 10d.).

Mill Hill Branch:—

Adult Education (Quarterly, 1/-).
Harpers Magazine (Monthly, 2/-).

15.—DELETIONS:

On the report of the Chief Librarian,

RESOLVED TO RECOMMEND—That the purchase of the following periodicals be discontinued:—

Central Library:—

British Journal of Photography (Weekly, 3d.).
Fortnightly (Monthly, 3/6d.).
Metal Industry (Weekly, 6d.).
Oil and Colour Trades Journal (Weekly, 6d.).

Mill Hill Branch:—

The Sociological Review (Quarterly, 5/-).

16.—DRAFT ANNUAL REPORT 1938/39:

The Committee had before them this report (copies having previously been circulated) and the same was duly **approved**.

The Committee expressed their thanks to the Chief Librarian for the manner in which the report had been compiled.

Report of the Housing Committee

3rd July, 1939.

COMMITTEE:

*Councillor F. W. Gilpin (*Chairman*).

Aldermen:

*W. M. Maughan, J.P.,

*R. A. B. Teare, M.B.E.

Councillors:

*T. K. Bridge,

G. Pinkney,

*G. R. Richardson,

*E. J. Cox,

*G. J. Pryke, F.I.A.C.,

T. J. Scott,

*P. Lightfoot,

A.M.I.S.E.,

(Mrs.) M. Thomas.

* denotes Member present.

1.—BOROUGH TREASURER'S DEPARTMENT (HOUSING)—EXAMINATION SUCCESSES:

With reference to the report of the Finance and General Purposes Committee (12/6/39—10) upon which special increments were granted to Miss P. E. Wardle and Miss O. F. Blott on passing the final examination of the Chartered Surveyors' Institution, the Committee desire to record their pleasure and have congratulated the recipients on their success.

2.—CONFERENCE:

An invitation was reported from The Institute of Housing with regard to the appointment of delegates to attend a Conference of the Institute to be held at Brighton from 21st—23rd September next.

RESOLVED—That no action be taken in the matter.

3.—TRANSFER OF TENANCIES:

The Housing Manager reported the following applications:—

Application

No.

5483 From a 2-bedroom type house at Brent Hill to a 2-bedroom flat at The Hyde.

4866 From a 3-bedroom type house at Brent Hill to a 3-bedroom flat at Bittacy Hill.

RESOLVED—That the applications be approved and transfers effected when suitable accommodation is available.

LODCERS.

4.—TENANT NO. 3893:

The Housing Manager submitted a further report with regard to this case as instructed at the last meeting (5). There are arrears of rent due from the Tenant and these are now being reduced by the sum of 2/6 weekly.

RESOLVED TO RECOMMEND—That the persons concerned be allowed to remain at the premises for a period of 12 months, when the case will be reviewed, subject to the regular payment of 2/6 weekly off the arrears.

5.—TENANT NO. 4655:

Having considered a report from the Housing Manager with regard to this case,
RESOLVED TO RECOMMEND—That the tenant be served with a notice to quit.

6.—ARREARS OF RENT:

The following tenants were reported to be four weeks or more in arrear:—

4701	5216	4366	2711
5033	4311	5565	5796
5926	5119	2807	6247
5447	3893	4832	6422

With regard to the under-mentioned, the position is as follows:—

4832	}	Notice to quit served.
5447		
4311	}	Payment off arrears being made.
5119		
3893		
5565		
2807		
4366		Arrears now satisfied.

RESOLVED TO RECOMMEND—

- (1) **That with regard to Tenant No. 4701, on whom a notice to quit was ordered to be served at the last meeting, that failing payment of the arrears forthwith action be taken as contemplated in the Housing Manager's report.**
- (2) **That a further report be submitted with regard to tenants Nos. 5033, 5926, 2711, 5796.**
- (3) **That failing payment of 2/7d. weekly (Tenant No. 5216) and not less than 4/- weekly (Tenant No. 6422) off the arrears they be served with a notice to quit.**

(A further decision with regard to Case No. 6422 is recorded in MS. in the Committee Minute Book.)

- (4) **That Tenant No. 6247 be required to pay a sum of 3/- weekly off the arrears.**

7.—HOUSING APPLICATIONS:

The following is a summary in connection with a new list of applications:—

Urgent A.1	10
Urgent C	2
List 1	10
List 2	1

23

Noted.

HOUSING REPAIRS, ETC.

13.—GENERAL FOREMAN:

It was reported that the recently appointed General Foreman commenced duty on June 12th and the work in connection with repairs was taken over from the Borough Surveyor's Department on June 21st. A statement was submitted as to workmen for transfer to the Housing Section, and the Housing Manager has been requested to submit a further report thereon at the next meeting.

14.—STORES:

The Housing Manager reported the need for a workshop, store and foreman's office which it was suggested should be provided at the rear of the Town Hall, and it was

RESOLVED—That the Borough Surveyor be requested to report upon the matter at the next meeting with an estimate of cost.

(The Finance and General Purposes Committee noted the above report).

Report of the Buildings and Town Planning Committee.

3rd July, 1939.

COMMITTEE:

*Councillor G. H. Hignett (*Chairman*).

Aldermen:

*W. R. Clemens, F.C.A.,

*S. H. Egan, J.P.

B. Flowers,

*J. J. Copestake, J.P.,

(*Deputy Mayor*),

Councillors:

E. Arter, M.C., M.I.A.E.,

*W. A. Hicks,

*W. H. N. Shakespeare,
M.C., A.F.C., J.P.,

*F. H. Bate,

*L. Hirshfield,

*H. P. Small.

J. Griffiths,

T. Pugh,

* denotes Member present.

HENDON PLANNING SCHEME NO. 1.

1.—161, HALE DRIVE MILL HILL:

The Borough Surveyor reported that he had interviewed the occupier of the above premises regarding the user of his house for business purposes in respect of which a complaint had been received from the Mill Hill Ratepayers' and Residents' Association (B. & T.P.C., 24/4/39—5).

It would now appear that the user of the premises does not contravene Clause 32 (5) of the Hendon Planning Scheme No. 1.

RESOLVED TO RECOMMEND—That no further action be taken in the matter.

2.—HIGHWOOD HILL TEA ROOMS—MILL HILL:

The Borough Surveyor reported on a letter from Mrs. Pring asking for a slight modification of the conditions contained in her agreement with the Council dated the 17th January, 1927, and scheduled in the Hendon Planning Scheme No. 1 (Clause 60) permitting the use of the above premises for the purpose of tea rooms. There would not appear to be any objection to a reasonable relaxation of the conditions of the agreement and the Committee

RESOLVED TO RECOMMEND—That the application be approved subject to the satisfaction of the Borough Surveyor as to the modified conditions, and that the necessary endorsement be made to the agreement in question.

3.—HALE END FARM, FARM ROAD, EDGWARE—APPEAL OF MR. J. S. GOFF:

The Town Clerk reported the receipt of a letter from the Minister of Health referring to the appeal of Mr. J. S. Goff against the refusal of the Council to consent to the transfer of an existing Petrol Pump from its present position to another position on land situate at Hale End Farm, Edgware. At the hearing of the appeal on the 5th May it was contended on behalf of the Appellant that the site to which the pump is to be transferred has been used by him for his business as a Contractor for many years. Inasmuch as the site is within the area of a residential zone of the Hendon Planning Scheme No. 1 the use of the site for this purpose constitutes a non-conforming user. Without prejudice to the question as to whether this use is an existing use, the Minister enquires whether the Town Council propose to take any action in regard to the present use of the site. In the meantime the Minister has deferred his decision on the appeal.

A report by the Borough Surveyor on the matter was also considered.

RESOLVED TO RECOMMEND—That the Minister be informed that it will be necessary for the Council to take action with regard to the present user of the land when the building development on the adjacent land is complete.

4.—FACTORY PREMISES, ENDERSLEIGH GARDENS, HENDON:

The Committee considered a letter from the Hendon Ratepayers' Association on behalf of certain residents of Endersleigh Gardens complaining of a nuisance caused by obnoxious smells emitted from the above Factory, and forwarding the following resolution passed by the Association.

"That the Hendon Borough Council be requested to call on Messrs. Bencard to abate the nuisance forthwith."

A report by the Senior Sanitary Inspector was also considered giving details of the various processes of manufacture carried out at the works, involving the boiling of liver.

The proprietor has informed the Senior Sanitary Inspector that the Company propose to carry out certain alterations to the plant by the introduction of steam for drying purposes, and it is anticipated that this will overcome the nuisance.

The premises, however, will be kept under observation and further visits will be made by the Senior Sanitary Inspector during the alterations to the plant.

RESOLVED TO RECOMMEND—That the Hendon Ratepayers' Association be informed accordingly.

5.—GENERAL GARAGE AND LIGHT FACTORY, CRICKLEWOOD LANE:

The Borough Surveyor reported on an application from Mr. G. J. Shaffer for consent to erect a single storey building to be used as a general garage and light factory on land situate in Use Zone I. (Residential) on the south east side of Cricklewood Lane, between No. 114 and the Cricklewood Trades Hall, opposite the end of Gillingham Road. The application has been advertised in accordance with Clause 30 of the Scheme and four objections including one from the Hampstead Borough Council, have been received.

RESOLVED—That consent be refused (Clauses 28 and 43) and the application be disapproved under the Restriction of Ribbon Development Act, 1935.

6.—LAND—JUNCTION OF WATFORD WAY WITH LAWRENCE STREET, MILL HILL:

The Borough Surveyor reported on a letter from Mr. W. F. Thorpe regarding the above vacant land and suggesting from a town planning point of view it would be beneficial to the district if this land was purchased by the Council. Mr. Thorpe enquires whether the Council would be prepared to enter into negotiations for the acquisition of the land in question.

RESOLVED TO RECOMMEND—That Mr. Thorpe's offer be not entertained.

7.—57, SELVAGE LANE, MILL HILL:

In connection with the use of the above premises for business purposes in contravention of the Hendon Planning Scheme No. 1 the Borough Surveyor reported that the occupier had applied for an extension of time in order to complete the removal of the remaining building materials from the premises (B. & T.P.C., 24/4/39—4).

RESOLVED TO RECOMMEND—That an extension of time until the end of October next be granted to the applicant.

HENDON PLANNING SCHEME NO. 2.

8.—1, 3, AND 5, BRAMPTON GROVE, HENDON:

The Borough Surveyor reported on an application from Messrs. Ranger, Burton and Frost on behalf of the Salvation Army, for an extension of the time limit for a period of two years in respect of the Interim Development Permission issued in connection with the re-development of the above properties and which expired on the 8th December, 1938 (B. & T.P.C., 22/11/37—18).

RESOLVED TO RECOMMEND—That the period of the Interim Development Permission be extended for two years.

9.—PREMISES—STANLEY ROAD, WEST HENDON:

The Committee considered an application from Messrs. Freke, Palmer, Romain and Romain for permission to use an existing two-storey building and yard on the north-west side of Stanley Road for the purpose of a rag and metal merchants business. The premises are situate within a Special Business area (Use Zone III.) of the Hendon Planning Scheme No. 2 and are covered by an existing industrial user. Under the Scheme, however, the business of a dealer in rags, etc., is classified as Special Industrial, and is not permitted in a special business zone.

RESOLVED—That such application be disapproved.

10.—LAND—CRICKLEWOOD LANE:

The Council on an application from Messrs. Towndrow & Ransom (B. & T.P.C., 21/11/38—7) approved the heads of an agreement in respect of the development of the above land fronting Cricklewood Lane, between Hendon Way and Granville Road for light industrial purposes. This agreement, however, has not yet been completed, and an application has now been received from Mr. W. Woodbridge Biggs for permission to develop approximately two acres of the land at the end nearest Granville Road, by the construction of factory buildings, the main building of which is approximately 150 feet wide, 300 feet deep, 45 feet high at the rear and 36 feet high at the front. On one side of the main building it is proposed to erect garage and workshops and on the other side a store (B. & T.P.C., 16/1/39—17).

RESOLVED—That such application be disapproved under the Hendon Planning Scheme No. 2 and under the Restriction of Ribbon Development Act, 1935.

11.—OPERATION OF HENDON PLANNING SCHEME NO. 2:

The Town Clerk reported that the above Scheme had been laid before both Houses of Parliament and that the Minister of Health had intimated that, provided the Scheme is not challenged in the Courts during the prescribed period of six weeks, it will become operative on the 22nd July, 1939. With regard to the sale of copies of the Scheme in its final form, on the suggestion of the Minister it had been agreed that the price to be charged shall be 1/6d. per copy, as in the case of Scheme No. 1.

RESOLVED TO RECOMMEND—That the action taken be approved.

12.—EMERGENCY OFFICES IN SUBURBAN OR COUNTY AREAS:

The Town Clerk reported the receipt of a letter from the Minister of Health enclosing for the information and guidance of the Council a copy of a Memorandum on the provision and use by business firms of emergency office accommodation in neutral areas outside London. The Minister considers that Planning Authorities in neutral

areas who receive applications from firms who desire to use buildings in areas that have been or are intended to be zoned as residential and in which accordingly business user is subject to the consent of the responsible authority, should give such applications favourable consideration, but that their consent might be subject to reasonable conditions such as that pending an emergency, business user of the premises should be limited to the storage of the necessary office furniture, supplies and records, that the actual transaction of business therein should be confined to the period of emergency itself (with a reasonable margin for the transfer of staff, etc.) and that the building should revert to its normal use when more normal conditions are restored. Also it may be proper to require that the external appearance of the building and grounds shall be reasonably well cared for and that except when business is actually being transacted, no business signs shall be displayed. **Noted.**

13.—TOWN AND COUNTRY PLANNING SUMMER SCHOOL:

A letter was submitted from the Hon. General Secretary of the Town and Country Planning Summer School inviting the Council to send representatives to attend the Summer School to be held at Bede College, Durham, from the September 1st-8th. Delegates fees are £1 11s. 6d. for the full week and £1 1s. 0d. for the week end. The board-residence fee is £3 4s. 6d. for the full week and £1 4s. 6d. for the week-end (Friday evening to Monday morning).

RESOLVED TO RECOMMEND—That no action be taken in the matter.

14.—BUILDING APPLICATIONS:

(A) The following applications were in order on submission and have been accordingly approved as indicated:—

Appl. No.	Description and Situation.	Public Health Act, 1936.	Town Planning.	Restriction of Ribbon Development Act, 1935.
A.5010v	2 houses, 66 and 68, Hartland Drive, Edgware. Owner and Applicant—John Laing & Son Ltd.	Approved	—	—
A.5670h	House, 7, Hunkins Lane, Mill Hill. Owner and Applicant—C. E. Matthews	Approved	—	—
A.7897c	Conversion of shops, plots 11 and 12, The Hyde, N.W. 9, into one shop. Owner and Applicant—Varley Estates Ltd.	Approved	—	—
A.7949a	Amended plan of addition to St. John's Vicarage, Vicarage Road, Hendon. Owner—Rev. R. W. Townsend. Applicant—G. L. Russell	Approved	—	—
A.8019a	Front service road and revised building line, Ionic Cinema, Finchley Road, N.W. 11. Applicant—W. J. King	Approved	—	—
A.8020a	Addition, 2, Edgwarebury Gardens, Edgware. Owner—A. E. Spurrier. Applicant—A. H. W. Toddman and Son	Approved	—	—
A.8072	Addition, 163, Station Road, Edgware. Owner—M. E. Mitzman. Applicant—Oram (Builders) Ltd.	Approved	—	—
A.8073	Garage and W.C., 105, Chevriot Gardens, N.W. 2. Owner and Applicant—C. S. Reeve	Approved	—	—
A.8100	Alterations, 149, Wentworth Road, N.W. 11. Owner and Applicant—F. J. Olden	Approved	—	—
A.8109	Garage, 35, Lyndhurst Avenue, N.W. 7. Owner—Mr. Pegley. Applicant—W. F. G. Latter	Approved	—	—
A.8110	Garage, 74, Oakhampton Road, Mill Hill. Owner—A. & B. Rose. Applicant—Hilbery Chaplin Ltd.	Approved	—	—

Consent given (Clause 43 (3))

Condition:—
That the east wall of the garage may be erected up to the owner's east boundary

Appl. No.	Description and Situation.	Public Health Act, 1936.	Town Planning.	Restriction of Ribbon Development Act, 1935.
A.S111	Air raid shelter, 7, West Heath Avenue, N.W. 11. Owner—T. Hardie. Applicant—F. Dymock Ltd.	Approved	—	—
A.S113	Garage, 37, Rowsley Avenue, N.W. 4. Greenfield. Applicant—S. J. West	Approved	—	—
A.S114	Air raid shelter, 38, Ravenscroft Avenue, N.W. 11. Applicant—Garsubil Ltd.	Approved	—	—
A.S116	Air raid shelter, 29, Northway, N.W. 11. Owner—T. A. Bourne. Applicant—F. Troy & Co. Ltd.	Approved	—	—
A.S118	House, 91, Platts Lane, N.W. 3. Owner—Senior Securities Ltd. Applicant—Bryant Hobbs	Approved	Consent given (Clause 42 (ii))	—
A.S119	Garage, 41, Wolmer Gardens, Edgware. Applicant—L. W. Lloyd	Approved	(i) That the proportion of site which may be covered by buildings shall not exceed 29 per cent. (ii) That consent No. 407 is hereby cancelled	—
A.S120	Air raid shelter, 16, West Heath Avenue, N.W. 11. Owner—Dr. P. C. Brett. Applicant—H. Cook	Approved	—	—
A.S123	Conversion of 9, Halegrove Gardens, N.W. 7, into two flats. Owner—G. Staves. Applicant—T. & E. Salter	Approved	—	—
A.S124	Garage, 34, Aldridge Avenue, Edgware. Applicant—W. L. Folkard	Approved	Consent given (Clauses 35 and 36)	—
A.S133	Garage, 29, Glenwood Road, Mill Hill. Applicant—W. F. F. Price	Approved	—	—
A.S135	Air raid shelter, 16, Selvage Lane, N.W. 7. A. T. Hawkins. Applicant—Horn & Co.	Approved	—	—
A.S139	Air raid shelter, Hylmary Cottage, Marsh Lane, Mill Hill. Owner—F. G. Roberts. Applicant—C. P. Roberts & Co. Ltd.	Approved	—	—

Air raid shelter, Hylmury Cottage, Marsh Lane, Mill Hill.
 Owner—E. G. Roberts. Applicant—C. P. Roberts & Co. Ltd.

Approved

Appl. No.	Description and Situation.	Public Health Act, 1936.	Town Planning.	Restriction of Ribbon Development Act, 1935.
A.8140	2 garages, plots 206 and 207, Kenilworth Road, Edgware. Owner and Applicant—Neasden Property Co.	Approved	—	—
A.8141	Extension to garage, Hendon Printing Works, Stratford Road, Hendon. Owner and Applicant—Hendon Printing Works Ltd.	Approved	Approved (Scheme 2) Interim Development Order:— That the work shall be actively commenced within twelve months of the date of this Order	—
A.8143	7 air raid shelters, 1 look-out chamber and 1 gas meter chamber, north side, Colindeep Lane, N.W.9. Owner and Applicant—Everett Edgecombe & Co. Ltd.	Approved.	—	—
A.8145	Extension to garage, 5, Turner Close, N.W.11. Owner—A. R. O. Slater. Applicant—F. Troy & Co.	Approved.	—	—
A.8146	House, 38, Glenwood Road, Mill Hill. Owner and Applicant—G. Wimpey & Co. Ltd.	Approved	Consent given (Clause 39)	—
A.8147	Addition, 165, West Heath Road, N.W.11. Owner—Z. F. Wilks. Applicant—Garsubill Ltd.	Approved	—	—
A.8149	Air raid shelter, 17, Hogcroft Road, N.W.2. Owner—C. C. Ducum. Applicant—Payne, Dyster & Sons	Approved	—	—
A.8155	Extension to garage, 9, Hillcrest Avenue, N.W.11. Owner—Miss M. A. Lee. Applicant—F. Lee	Approved	—	—
A.8156	Infants and Junior School, and caretaker's bungalow, west side, Broadfields Avenue, Edgware. Owner—Borough of Hendon. Applicant—J. W. Gilmour Wilson	Approved	Consent given (Clause 28)	—
A.8160	Beer store, 135, Deans Lane, Mill Hill. Owner and Applicant—Charrington & Co. Ltd.	Approved.	—	Approved.
A.8161	Engineer's store, Redhill County Hospital, Barnet Oak Broadway, Edgware. Owner and Applicant—Middlesex County Council	Approved.	—	—
A.8162	House, Redhill County Hospital, Deansbrook Road, Edgware. Owner and Applicant—Middlesex County Council	Approved.	—	Approved

Appl. No.	Description and Situation.	Public Health Act, 1936.	Town Planning.	Restriction of Ribbon Development Act, 1935.
A.S163	4 houses, 2, 4, 6 and 8, Bedford Road, N.W. 7. Owner and Applicant—G. Wimpey & Co. Ltd.	Approved	—	—
A.S165	Alterations, 122, Brent Street, Hendon. Applicant—Boots Pure Drug Co. Ltd.	Approved	—	—
A.S167	Addition, Sunnyfields Lodge, Lawrence Street, Mill Hill. Owner—Mrs. Galain. Applicant—M. Chesterton	Approved	—	—
A.S170	Garage, 12, Sherrock Gardens, Hendon. Owner and Applicant—S. A. Barlow	Approved	—	—
A.S173	Internal partitions and alterations to shop, south side, Crickelewood Lane, N.W. 2. Owner—United Trust and Land Co. Ltd. Applicant—Armitage & Son	Approved	—	Approved.
A.S174	36 houses and bungalows, 1-21, Salcombe Gardens, 2-22, Woodcote Avenue, 1-17, Rushden Gardens, 2-10, Harefield Green, Mill Hill. Owner—A. Graham. Applicant—W. F. Thorpe	Approved	—	—
A.S150	House and garage, plot 1, Broadfields Avenue, Edgware. Owner and Applicant—H. J. Hook & Son	Approved	—	—
A.S131	Extension to factory, north-east side, West Hendon Broadway, N.W. 9. Owner—Eugène Ltd. Applicant—Bethell & Swannell	Approved	—	—

(B) The following applications were not in order on submission and have been accordingly **disapproved** as indicated:—

A.S127	Factory extension, north-east side, The Hyde, N.W. 9. Owner—Duple Bodies & Motors Ltd. Applicant—Dudley G. Marsh	Disapproved (Byelaw 94 (4) (f))	Consent refused (Clause 6)	Disapproved.
A.S154	Garage, 149, Station Road, Edgware. Owner and Applicant—L. Raymond	Disapproved (Section 55)	Consent refused (Clause 42 (h))	—

(C).

Applications Considered.

The following applications required special consideration and the Committee's decision is given in each case hereunder:—

A.S108	32 flats, east side, and 32 flats, west side, Malcolm Crescent, Hendon, and 15 garages. Owner—M. Paul and Garvin. Applicant—W. F. Hobbs	Approved	Consent refused (Clauses 35, 36 and 43)	—
--------	---	----------	---	---

A.8108 32 flats, east side, and 32 flats, west side, Moleho
Crescent, Hendon, and 15 garages. Owner—M. Paul
and Garvin. Applicant—W. F. Hobbs

Approved

Consent refused (Clauses 35, 36
and 43)

Restriction of Ribbon
Development Act, 1935.

Town Planning.

Public Health Act, 1936.

Appn.
No.

Description and Situation.

Public Health Act, 1936.

Town Planning.

Restriction of Ribbon
Development Act, 1935.

Appn.
No.

Description and Situation.

Public Health Act, 1936.

Town Planning.

Restriction of Ribbon
Development Act, 1935.

Appn.
No.

Description and Situation.

Public Health Act, 1936.

Town Planning.

Restriction of Ribbon
Development Act, 1935.

Appn.
No.

Description and Situation.

Public Health Act, 1936.

Town Planning.

Restriction of Ribbon
Development Act, 1935.

Appn.
No.

Description and Situation.

Public Health Act, 1936.

Town Planning.

Restriction of Ribbon
Development Act, 1935.

Appn.
No.

Description and Situation.

Public Health Act, 1936.

Town Planning.

Restriction of Ribbon
Development Act, 1935.

Appn.
No.

Description and Situation.

Public Health Act, 1936.

Town Planning.

Restriction of Ribbon
Development Act, 1935.

Appn.
No.

Description and Situation.

Public Health Act, 1936.

Town Planning.

Restriction of Ribbon
Development Act, 1935.

A.8127

Air raid shelters and other units, west side, Sheaveshill
Avenue, N.W. 9. Owner—Titanic Ltd. Applicant
—Stephen A. Todd

Approved

Consent given (Clause 28)

A.8142

Hall and additions to St. Agnes' R.C. School, Cadding-
ton Road, N.W. 2. Owner—Westminster Diocesan
Trustees. Applicant—Thomas H. B. Scott

Approved

Consent given (Clause 28)

A.8164

Alterations, 2-4, Church Road, Hendon. Owner and
Applicant—United Dairies London Ltd.

Approved

Consent given (Clause 28)

A.8176

Addition, St. Vincent's Convent, The Ridgeway, Mill
Hill.
Owner—The Community of St. Vincent's Convent.
Applicant—Emden Egan & Co.

Approved

Consent given (Clause 28)

Approved (Scheme 2)
Interim Development Order:—
That the work shall be
actively commenced within
twelve months of the date
of this Order

Consent given (Clause 28)

Consent given (Clause 28)

Consent given (Clause 28)

Consent given (Clause 28)

That the external stairs shall
be either enclosed within
the building or contained
within surrounding walls

Approved.

Condition:—
That the existing crossings
over the public footpath of
Prince of Wales Road shall
be altered or removed as
required and that the exist-
ing crossing over the public
footpath of Church End
shall be removed; the work
to be carried out by the
Council after a deposit has
been paid by the applicant
to cover the estimated cost.

Approved.

Consent given (Clause 28)

15.—TEMPORARY BUILDINGS:

Applications in Order.

(A) The following applications for temporary buildings were in order on submission, and the Committee RECOMMEND—That such applications be approved for a period expiring on the 31st March, 1942:—

Appln. No.	Description and Situation.	Public Health Act, 1936.	Town Planning.	Restriction of Ribbon Development Act, 1935.
A.8078	Garage, 20, Fernside Avenue, Mill Hill. Applicant—G. W. B. Ives	Owner and Approved	—	—
A.8091	Garage, 79, Oakhampton Road, Mill Hill. Applicant—J. W. Marshall	Owner and Approved	—	—
A.8112	Garage, 43, Colin Park Road, N.W. 9. Applicant—C. M. Diss	Owner and Approved	—	—
A.8115	Garage, 127, Devonshire Road, Mill Hill. Applicant—R. H. Hill	Owner and Approved	—	—
A.8117	Garage, 14, Glenwood Road, Mill Hill. Applicant—F. N. Boysen	Owner and Approved	—	—
A.8121	Garage, 60, Pennine Drive, N.W. 2. Owner and Applicant—R. Stoker	Owner and Applicant— Approved	—	—
A.8122	Garage, 43, Glendor Gardens, Mill Hill. Applicant—S. V. Parnell	Owner and Approved	—	—
A.8125	Garage, 32, Clovelly Avenue, N.W. 9. Applicant—D. S. G. Davies	Owner and Approved	—	—
A.8128	Garage, 48, Hillview Gardens, Hendon. Applicant—S. F. R. May	Owner and Approved	—	—
A.8129	Garage, 25, Cleveland Gardens, N.W. 2. Applicant—A. F. Reeve	Applicant— Approved	—	—
A.8130	Garage, 156, Chantonbury Way, N. 12. Applicant—E. C. P. White	Owner and Approved	—	—
A.8132	Lean-to greenhouse, 13, Ashley Walk, Hendon. Owner and Applicant—J. Deighton	Owner and Applicant— Approved	—	—
A.8134	Garage, plot 15, Kenilworth Road, Edgware. Owner and Applicant—R. Perry	Owner and Applicant— Approved	—	—

Appl. No.	Description and Situation.	Public Health Act, 1936.	Town Planning.	Restriction of Ribbon Development Act, 1935.
A.8134	Garage, plot 15, Kenilworth Road, Edgware. Applicant—R. Perry	Approved	—	—
A.8136	Garage, 12, Fernside Avenue, Mill Hill. Applicant—M. Rose	Approved	—	—
A.8144	Garage, 17, Cheviot Gardens, N.W.2. Applicant—W. Wiltshire	Approved	—	—
A.8148	Garage, 207, Watford Way, Hendon. Applicant—H. W. Hicks	Approved	—	—
A.8151	Garage, 68, Fraucklyn Gardens, Edgware. Applicant—H. L. Jarman	Approved	—	—
A.8157	Garage, 10, Ellesmere Avenue, Mill Hill. Applicant—L. R. Zazzi	Approved	—	—
A.8158	Garage, 32, Station Road, Edgware. Wells. Applicant—R. O'Dell	Approved	—	—
A.8159	Garage, 41, Sunbury Avenue, Mill Hill. M. A. Simpson. Applicant—J. Childs & Son Ltd.	Approved	—	—
A.8171	Garage, 61, Selborne Gardens, Hendon. Applicant—C. W. B. Simmons, Ltd.	Approved	Consent given (Clause 42 (ii)) Condition:— That the proportion of site which may be covered by buildings shall not exceed 35 per cent.	—
A.8166	Garage, 56, Glengall Road, Edgware. Applicant—B. Tuckman	Approved	—	—

(B) The following application for a temporary building required special consideration, and the Committee

RECOMMEND—That such application be approved for a period expiring on the 31st March, 1942:—

A.8025a Workshop, east side, The Hyde, N.W.9. Applicant—Romac Motor Accessories Ltd.

Approved

16.—CRANMER ROAD AND LYNFORD GARDENS, EDGWARE:

The Borough Surveyor reported on a petition signed by the occupiers of houses formerly unofficially numbered 28-36, Lynford Gardens, Edgware, regarding the description of their premises and objecting to the re-numbering of their houses in Cranmer Road and suggesting that a deputation should be received. Lynford Gardens was laid out in conjunction with two other roads named Cranmer Road and Wyre Grove. The section of road in question is shown as Cranmer Road on the deposited plans, but one of the builders working on the estate numbered the houses in Lynford Gardens. In order to overcome the confusion thus caused, the Council (B. & T.P.C., 13/3/39—18) authorised the re-numbering of certain houses to fit in with the numbering of Cranmer Road which is the official name of the road concerned. It would appear that any further alteration in the description of such premises would create further confusion and no useful purpose would be served by the reception of a deputation.

RESOLVED TO RECOMMEND—That the petitioners be informed accordingly.

Report of the Rating and Valuation Committee.

11th July, 1939.

COMMITTEE:

*Councillor H. P. Small (*Chairman*).

Aldermen:

*S. H. Egan, J.P.
(*Deputy Mayor*),

B. Flowers.

Councillors:

E. Arter, M.C., M.I.A.E.,
*H. Connell, J.P.,

E. J. Cox,
*A. W. Curton,

*W. A. Hicks,
G. F. Windust.

* denotes Member present.

VALUATIONS.

1.—69th PROPOSAL LIST:

It was reported that this List was approved by the Central Middlesex Assessment Committee on the 14th June and resulted in a net increase in rateable value of £2,108 (Hendon £1,740, Edgware £368). There were seven objections and one de-rating claim by ratepayers to entries in the list, out of which the assessments proposed were confirmed in five cases, two cases withdrawn, and the de-rating claim was allowed.

Noted.

2.—70th PROPOSAL LIST:

Valuation Sheets Nos. 9 to 21 were submitted containing assessments included in the above List, which comprises 290 entries (Hendon 192, Edgware 98). This List will be deposited with the Central Middlesex Assessment Committee on the 19th instant and, subject to objections, will be approved on the 26th instant. The List discloses a provisional increase of rateable value of £3,516 (Hendon £3,133, Edgware £383).

RESOLVED—That the assessments contained in Valuation Sheets Nos. 9 to 21 be approved and signed.

3.—REQUISITIONS:

Requisitions amounting to £4 10s. 0d. for stationery, etc., were **approved**.

(Other matters dealt with are recorded in MS. in the Committee's Minute Book.)

Report (No. 1) of the Air Raid Precautions Committee.

27th June, 1939.

COMMITTEE:

***Councillor E. Arter, M.C., M.I.A.E. (Chairman).**

Aldermen:

W. R. Clemens, F.C.A., ***J. J. Gopestake, J.P.**

Councillors:

<p>*F. H. Bate, F. J. Collins, *A. W. Curton, J. Griffiths, *W. A. Hicks,</p>	<p>*C. H. Hignett, *L. Hirshfield, *A. A. Naar, M.B.E., *C. Pinkney, *H. G. Potter, J.P., F.S.I. <i>(Mayor),</i></p>	<p>*T. J. Scott, *W. H. N. Shakespeare, M.C., A.F.C., J.P., *C. F. Windust.</p>
--	---	---

Representatives of A.R.P. Services:—

British Red Cross Society	*Mrs. J. F. Harvey.
Wardens' Organisation	*Captain A. C. Petrie.
Auxiliary Fire Service	Mr. Harold Bevir.

* denotes attendance at Meeting.

1.—CHAIRMAN:

In the absence of the Chairman of the Committee at the commencement of the Meeting. His Worship the Mayor was elected to the Chair.

(His Worship the Mayor (Councillor H. G. Potter, J.P., F.S.I.) in the Chair).

SHELTER ACCOMMODATION.

2.—TRENCHES IN COURSE OF CONSTRUCTION:

The Borough Engineer reported on the present position of the work of lining and completing trenches already excavated in the various parks as follows:—

Stone Grove Park	} Completed.
Hendon Park	
Child's Hill Park	
Watling Park	
York Park	
Hampstead Heath Extension		Fixing of steel linings half completed.
Clitterhouse Playing Fields		Lining of the trenches in these Parks will
Mill Hill Park	be commenced early next week.

Noted.

3.—ADDITIONAL TRENCHES:

At the last Meeting of the Committee (A.R.P.C., 13/6/39—1 (b)) the suggestion of the Borough Engineer that the linings for the additional trenches should be 7 feet in width was adopted subject to the approval of the Middlesex County Council and the Home Office. The Borough Engineer now reports that the Home Office will not consider the suggested design of trench, and he had, therefore, reverted to the original proposal limiting the width to 5 feet and that tenders will now be invited on the basis of the original proposals. **Noted.**

4.—TRAINING OF AMBULANCE DRIVERS:

The Borough Surveyor reported that of the 96 women ambulance drivers at present under instruction, 80 have now reached the stage of driving on the public highway and that 25 of these are now practising driving in civilian duty respirators. **Noted.**

5.—TRANSPORT:

The Borough Surveyor reported that the Traffic Commissioners had deleted from the list of earmarked vehicles the 30 breakdown lorries which were reserved for fire brigade purposes, as it is considered that under war conditions there may be an increased need for breakdown vehicles and it is inadvisable that vehicles specially fitted with apparatus for such work should be dismantled in order to be used for air raid precautions purposes. The Borough Surveyor has, therefore, obtained 30 other vehicles to replace the breakdown vehicles previously earmarked and has forwarded the registration numbers to the traffic commissioners. **Noted.**

6.—PERSONNEL—DECONTAMINATION, RESCUE AND AMBULANCE SERVICES:

The present stage of training of the personnel for the above services is as follows:—

Trained in Anti-gas Measures	66
Trained in Anti-gas and Decontamination	30
In course of training	89
Total	185

In addition, 60 members of the light and heavy rescue parties have commenced a short first aid course. **Noted.**

7.—RESCUE AND DEMOLITION SERVICES:

The Borough Engineer reported a letter from the County Engineer intimating that as a result of the meeting of the Executive Committee of the Federation of Civil Engineers and Contractors the following firms have been allotted to place their plants and services at the disposal of this Council in the event of emergency:—

Howard Farrow Ltd.
John Laing & Son Ltd.

In this connection the Borough Engineer submitted suggestions relative to the constitution of the proposed Committee (A.R.P.C., 16/5/39—10; 13/6/39—3) for dealing with the question of the recruitment of labour for the rescue, demolition and decontamination services and any other matters requiring the services of outside Contractors.

RESOLVED TO RECOMMEND—That the Committee consist of the Chairman of this Committee (Councillor E. Arter, M.C., M.I.A.E.), the Borough Engineer, the Deputy Borough Engineer, Mr. Howard Farrow or his representative, and Mr. John Laing or his representative, such Committee to be empowered to co-opt as may be deemed necessary.

8.—MULTI-PURPOSE BUILDINGS:

The Borough Engineer reported that the working drawings of the multi-purpose buildings for submission to the County Council for approval and loan sanction were completed and that the detailed estimates to accompany the application would be ready in the next few days. The necessary revisions had also been made to the set of plans as a result of the decision to erect the multi-purpose building to serve the Northern Division in Daws Lane. **Noted.**

9.—DEPOTS—SHORT TERM POLICY:

The Committee on the 8th March last (A.R.P.C., 8/3/39—1) approved of Mill Hill Swimming Pool being used as a Depôt to serve the Northern Division and the West Hendon Swimming Pool to serve as a Depôt for the Central Division, but no decision was reached regarding a Depôt to serve the Southern Division in relation to the short term policy.

As some time is likely to elapse before the multi-purpose buildings to be erected in the three Divisions will be ready for use, the Borough Engineer suggested that the Central Depôt, Hendon Way, should be scheduled to serve the Southern Division in the event of an emergency arising in the near future. He was, therefore, preparing plans of the adaptation work which will be required to the three Depôts, together with lists of the materials which it would be necessary to assemble and store in the vicinity of such Depôts, as it would not be possible, without affecting the user, to put the actual work in hand until an emergency arises. The plans of the adaptation work, together with estimates of costs will be submitted to the Middlesex County Council as early as practicable.

RESOLVED TO RECOMMEND—That the proposals indicated in the report of the Borough Surveyor be approved and adopted.

10.—STORAGE OF SANDBAGS—MONTROSE PARK:

The Borough Engineer reported that the conversion of the railway arch in Montrose Park had now been completed and was in readiness to store the Council's issue of sandbags. **Noted.**

11.—REQUISITIONS:

Requisitions were submitted as follows:—

	£	s.	d.
Borough Engineer's Department	38	5	0
Air Raid Precautions Department	322	5	0

The Committee have approved the requisitions amounting to £38 5s. 0d. submitted by the Borough Engineer, and have referred the requisitions submitted by the Air Raid Precautions Officer for consideration by a Sub-Committee consisting of the Chairman of the Committee, Councillor Naar and the Air Raid Precautions Officer with power to act.

12.—HOUSEHOLDERS STEEL AIR RAID SHELTERS:

The Borough Engineer reported that a communication had been received from the Home Office intimating that supplies of the special steel shelters for householders will shortly become available for delivery in the Borough and that he was taking the necessary steps to obtain the lists of occupiers qualified to receive such shelters.

In this connection attention was called to paragraph 10 of the Home Office A.R.P. Department Circular No. 28/1939, dated 8th February last which states that where the householder prefers to have the shelter erected and sunk now, Local Authorities may, if they wish, arrange to have the work done and the cost of the work will rank for grant under the Act. Attention was also directed to Middlesex County Council Circular No. 52, dated the 24th June in the following terms:—

"The Civil Defence Bill authorises local authorities, with the consent of the occupier of the premises, to undertake at the public expense the work of excavation and of erection. This is likely to entail a heavy burden on the ratepayers, and the County Council, while prepared to follow the lead of the Government and to recognise all necessary expenditure for grant, relies on the Councils of County districts to encourage householders to erect their own shelters and to keep within proper limits the expenditure incurred when the authority erects the shelters. It is understood that the average cost in other suburban areas has been found to vary between £1 10s. 0d. per shelter and £2 5s. 0d. per shelter (including super-

vision), and while it is considered that the latter figure should not be exceeded in any district in Middlesex, it is confidently hoped that in most areas the average cost per shelter will be kept under £2. The Lord Privy Seal has stated that he will not recognise for grant any wages for casual labour in excess of trade union rates locally operating -- or wages for holidays other than those to which the local trade union conditions apply."

The Committee have considered as to the policy to be adopted by the Council in relation to the erection of householders shelters, and

RESOLVED TO RECOMMEND—That the erection of the householders steel air raid shelters be carried out by the Council.

In the event of additional assistance being required in connection with the shelter census, the Committee have directed the Borough Engineer to bear in mind the possibility of employing unemployed A.R.P. volunteers.

13.—HOME OFFICE AID RAID PRECAUTIONS SCHOOL—FALFIELD:

The Borough Engineer reported that Mr. J. O. Vine of his department who recently attended the Home Office A.R.P. School of Instruction at Falfield, Gloucester, had obtained a "Special" certificate in Air Raid Precautions (anti-gas, control of incendiary bombs and elementary methods of protection from high explosive bombs).

A "Special" Certificate is only granted to candidates obtaining a minimum of 80 per cent. in the theoretical examination and 85 per cent. in the practical examination.

RESOLVED—That Mr. Vine be congratulated on his success.

(Councillor E. Arter, M.C., M.I.A.E., in the Chair.)

14.—MEDICAL SERVICES PERSONNEL:

The Medical Officer of Health reported that there is a serious shortage of male personnel in the medical services organisation, the various sections being 388 under strength. This does not take into account the personnel of the St. John Ambulance Brigade of whom it was hoped that 150 would be available, but it has now been ascertained that by a ruling of the St. John Ambulance Brigade these men must in war serve in the area in which they reside. So far as Hendon is concerned this will have the effect of reducing the number of St. John Ambulance personnel who will be available from 150 to approximately 70. The Committee fully realise the gravity of the situation and have considered as to what action should be taken to bring the male personnel up to strength.

RESOLVED TO RECOMMEND—That all employers and organisations throughout the Borough be circularised with a view to obtaining the full complement of volunteers for stretcher bearer parties and first aid post work and that the requisite courses of instruction be arranged in various parts of the Borough to meet the convenience of volunteers as far as practicable.

15.—RECRUITING, TRAINING AND ORGANISATION OF A.R.P. PERSONNEL:

The Chairman of the Committee undertook to arrange a conference of the Chief Officers concerned with the recruiting, training and organisation of A.R.P. personnel with a view to co-ordination of effort being ensured.

16.—COLLECTIVE TRAINING FOR FIRST AID POSTS:

Arising out of Ministry of Health Circular No. 1831 which deals with collective training for First Aid Posts, the Medical Officer of Health reported that, with the exception of the First Aid Post at Redhill County Hospital, it would not be possible to use the designated First Aid Posts for such training as they have either not yet been built or adapted for the purpose.

The Circular states that exercises should be held where possible at one of the designated posts, whether existing medical buildings or buildings adapted *ad hoc*, but that where this is not possible arrangements should be made to use some other suitable building.

The Health Centre at Hartley Avenue could readily be adapted without interference with its ordinary peace-time user, but so far as the rest of the area is concerned, it will be necessary to arrange alternative accommodation for training purposes in other suitable buildings, such as clinics, schools and halls, and the Medical Officer of Health asked for authority to proceed with such arrangements.

RESOLVED TO RECOMMEND—That the adaptation work to be carried out at the Health Centre, Hartley Avenue, Mill Hill, for the purpose of a First Aid Post, be put in hand forthwith, and that the Medical Officer of Health be authorised to make arrangements for suitable accommodation to be available in other parts of the Borough for the purpose of the collective training of First Aid Post Staffs.

Amendment

Before detailed consideration of the motion, the Finance and General Purposes Committee Recommend— That the following words be inserted after the word "That" in the first line of the recommendation:—

"subject to the approval of the Middlesex County Council to the expenditure, estimated at £50."

17.—HENDON PHARMACISTS:

A memorandum signed by 27 Pharmacists in the Borough, all of whom are qualified Air Raid Wardens, was submitted suggesting:—

- (a) *that two or more Pharmacists should be attached to the Medical Officer of Health for the purpose of the purchase and control of drugs and dressings necessary for Air Raid Precautions, and that their wide experience and knowledge in these matters must of necessity be of the greatest value;*
- (b) *that one or more Pharmacists should be attached to each First Aid Post for the control of the supply and maintenance of drugs and dressings,*

and offering to prepare and submit a scheme whereby a comparatively large quantity of medical supplies could be collected from the pharmacists in the Borough and delivered to any given place at very short notice should an emergency arise.

The Committee have received the observations of the Medical Officer of Health on the memorandum, and understand (*vide* Ministry of Health Circular No. 1789), that the Minister of Health is arranging for the purchase of all the main surgical and medical equipment for fixed first aid posts and mobile units centrally and to distribute them to Scheme-making Authorities.

The arrangements for the storage of drugs and dressings for first aid posts are also prescribed by the Minister of Health.

Having regard to the observations of the Medical Officer of Health, the Committee **RESOLVED TO RECOMMEND—That the signatories to the Memorandum be informed that the Committee will be prepared to consider a scheme to be submitted by them if they so desire within the prescribed limits.**

18.—AUXILIARY NURSING:

The Committee have instructed the Medical Officer of Health to report to the next Meeting of the Committee as to the number of volunteers being trained in the Borough under the Auxiliary Nursing Scheme.

19.—AIR RAID WARDENS' ORGANISATION—COMMUNICATIONS, ETC.—RECRUITMENT AND TRAINING:

The present position in regard to the recruitment and training of the Air Raid Wardens' Organisation, Report Centre Staffs, Messengers and Miscellaneous Services, is as follows:—

Air Raid Wardens:—

War Establishment and Reserve	2,400
Enrolled to date	1,994
Trained in Anti-Gas Measures	1,562
In training:—											
First Aid	1,313
Anti-Gas	290
Enrolled but no training commenced	142

Report Centre Staffs:—

War Establishment and Reserve	180
Enrolled to date	148
In training (Anti-Gas)	137
Enrolled but no training commenced	11

Messengers:—

War Establishment and Reserve	112
Enrolled to date	64
Trained in Anti-Gas Measures	26
Enrolled but no training commenced	38

Miscellaneous Service:—

Enrolled to date	233
In training (Anti-Gas)	220
Enrolled but no training commenced	13

Noted.

20.—WARDEN OFFICIAL INSTRUCTORS:

The Air Raid Precautions Officer reported that 21 Warden officials are in the course of undergoing training as Instructors.

21.—AIR RAID WARDENS' ORGANISATION:

The re-organisation of the Wardens' groups has been completed, the number of Groups now constituting each Division being as follows:—

Division I.	9
Division II.	6
Division III.	6

Air Raid Wardens' Posts have also been sited and the organisation has now reached the stage that it can be discussed with the Regional Officer and the Principal Warden with a view to getting the sites agreed upon, after which the steps for the provision of the posts can be proceeded with. In this connection the Air Raid Precautions Officer reported that he had arranged to meet the Principal Warden on the 28th instant. **Noted.**

22.—DIVISIONAL WARDENS—CLERICAL ASSISTANCE:

The Air Raid Precautions Officer reported that in view of the fact that the internal administration of the Air Raid Wardens' Organisation is being handed over as far as possible to the Warden officials it is now necessary to establish each Divisional Office on a proper basis, and that having regard to the amount of clerical work which will be performed at the Divisional Wardens' Offices, clerical assistance would be needed.

The County Air Raid Precautions Officer has intimated that the actual expenses incurred by Divisional Wardens on typing assistance will rank for grant and whilst at present the amount expended on clerical assistance varies in the three Divisions, in order that the Wardens' organisation shall be in a position to function efficiently the Air Raid Precautions Officer recommended that each Divisional Warden be authorised to expend a sum of 30/- per week on clerical assistance.

RESOLVED TO RECOMMEND—That the report of the Air Raid Precautions Officer be approved and authority given to an expenditure of 30/- per week on clerical assistance for each Divisional Warden.

23.—TRANSPORT AND EQUIPMENT:

The Air Raid Precautions Officer suggested that one of the vans used for the purpose of training ambulance drivers should also be utilised for the transport of training equipment, and thus serve a dual purpose, one of the storekeepers acting as driver.

RESOLVED TO RECOMMEND—That the suggestion of the Air Raid Precautions Officer be adopted.

24.—COURSE OF INSTRUCTION FOR L.A.R.P. INSTRUCTORS:

The Air Raid Precautions Officer reported that as a result of the Civil Defence Bill, which provides that a proportion of the persons employed in factories and commercial buildings shall be trained in air raid precautions, the number of Instructors available in the Borough is insufficient to meet the demand. He proposed, therefore, with the approval of the County Council—which had been obtained—to arrange a course of training for ten L.A.R.P. Instructors, and the factories and commercial houses would be given an opportunity to nominate candidates for the course.

RESOLVED TO RECOMMEND—That the proposals of the Air Raid Precautions Officer be approved.

25.—HOME OFFICE INCENDIARY BOMB AND HIGH EXPLOSIVE SCHOOL, WANDSWORTH:

The Air Raid Precautions Officer reported that, as a matter of urgency and after consultation with the Medical Officer of Health, Mr. F. H. Day had been nominated to attend a course of instruction at the Home Office Incendiary Bomb and High Explosive School, Wandsworth, from the 26th to the 30th June.

RESOLVED—That the action taken be confirmed.

26.—A.R.P. HEADQUARTERS—RAVENSFIELD—TELEPHONES:

The Air Raid Precautions Officer reported that in view of the urgency for his Department to be established at Ravensfield as early as possible, he had arranged for the necessary telephones to be installed.

RESOLVED—That the action taken by the Air Raid Precautions Officer be confirmed.

27.—APPOINTMENT OF CHIEF AIR RAID WARDEN:

Pursuant to the instructions given at the last meeting of the Committee (A.R.P.C., 13/6/39—21) the Air Raid Precautions Officer reported with reference to the appointment of a Chief Warden and the Committee have agreed to the Air Raid Precautions Officer's suggestion that he be allowed up to the expiration of the period of three months from the adoption by the Council on the 8th May last of recommendation No. 16 of the Committee's report of the 24th April, to submit a recommendation.

28.—REPRESENTATION ON COMMITTEE—HENDON AND DISTRICT TRADES' COUNCIL:

A letter was submitted from the Hendon and District Trades' Council asking to be represented on the Committee.

RESOLVED TO RECOMMEND—That the Hendon and District Trades' Council be informed that in the event of any matters coming before the Air Raid Precautions Committee in which their services could be utilised with advantage they will be invited to send a representative to attend meetings of the Committee at which such matters may be under consideration.

29.—RE-HOUSING OF PERSONS DISPLACED BY REASON OF WAR DAMAGE:

His Worship the Mayor reported that he hoped to present to the next meeting of the Committee details of a scheme for the re-housing of persons who may be displaced by reason of war damage.

30.—CANTEENS FOR AIR RAID PRECAUTIONS PERSONNEL:

The Town Clerk reported that the Mayoress had been approached with a view to organising the canteens which will be necessary for the Air Raid Precautions personnel in the event of an emergency arising, and she was prepared to undertake the work. Up to the present time it would not appear possible to proceed further than the obtaining of the requisite voluntary personnel as there was no authority to incur expenditure. In this connection the Air Raid Precautions Officer intimated to the Committee that as Controller he would be required to make certain contracts and draw up a scheme for feeding the personnel.

RESOLVED TO RECOMMEND—That the Mayoress be informed that the Council will be pleased to avail themselves of her services in the organisation of the canteen personnel.

Report (No. 2) of the Air Raid Precautions Committee.

3rd July, 1939.

COMMITTEE:

***Councillor E. Arter, M.C., M.I.A.E. (Chairman).**

Aldermen:

***W. R. Clemens, F.C.A.,**

***J. J. Copestake, J.P.**

Councillors:

***F. H. Bate,
F. J. Collins,
A. W. Curton,
J. Griffiths,
*W. A. Hicks,**

***C. H. Hignett,
*L. Hirshfield,
*A. A. Naar, M.B.E.,
C. Pinkney,
*H. C. Potter, J.P., F.S.I.
(Mayor),**

**T. J. Scott,
*W. H. N. Shakespeare,
M.C., A.F.C., J.P.,
*C. F. Windust.**

Representatives of A.R.P. Services:—

British Red Cross Society	Mrs. E. Monro, J.P.,
Wardens' Organisation	*Captain A. G. Petrie,
Auxiliary Fire Service	*Mr. Harold Bevir.

** denotes attendance at Meeting.*

AIR RAID PRECAUTIONS ORGANISATION:

A verbal report was submitted by the Air Raid Precautions Officer indicating the present position of the air raid precautions organisation and making suggestions for accelerating progress on the scheme.

A report directing attention to the necessity for completing the short term scheme and also proceeding concurrently, as rapidly as possible, with the long term policy was also submitted by the Town Clerk.

With a view to accelerating the progress of all A.R.P. matters, the Committee

RESOLVED TO RECOMMEND—

- (a) That **Mr. F. H. Day** of the Public Health Department be seconded for duty with the Air Raid Precautions Officer for a period of one month and the position reviewed at the expiration of this period.
- (b) That a Special (Air Raid Precautions) Sub-Committee be appointed consisting of:—

**His Worship the Mayor,
The Chairman (Councillor E. Arter, M.C., M.I.A.E.),
Councillor A. A. Naar, M.B.E.,
Councillor C. Pinkney,**

to whom shall be delegated the powers and duties of the Council under the Air Raid Precautions Act, 1937 (except Air Raid Fire Precautions), subject to the submission of reports on the action taken to the Council through the Air Raid Precautions Committee to be convened as and when considered necessary by the Special (Air Raid Precautions) Sub-Committee.

- (c) That Standing Order No. 15 in its application to the Air Raid Precautions Sub-Committee, be suspended.
- (d) That in the event of Councillor C. Pinkney being unable to attend any meeting of the Sub-Committee, Councillor A. W. Curton be invited to complete the constitution.

Report of the Finance and General Purposes Committee.

10th July, 1939.

COMMITTEE:

*Alderman W. R. Clemens, F.C.A. (*Chairman*).

Aldermen:

*J. J. Copestake, J.P.,

S. H. Egan, J.P.
(*Deputy Mayor*),

B. Flowers,

Councillors:

*E. Arter, M.C., M.I.A.E.,

*L. Hirshfield,

*G. R. Richardson,

F. J. Collins,

*P. Lightfoot,

*T. J. Scott,

*A. W. Curton,

*A. A. Naar, M.B.E.,

*W. H. N. Shakespeare,

*F. W. Gilpin,

*C. Pinkney,

M.C., A.F.C., J.P.

*G. H. Hignett,

*H. G. Potter, J.P., F.S.I.
(*Mayor*),

*H. P. Small.

* denotes Member present.

1.—CASH STATEMENT:

The financial and statistical appendix has been examined by Councillor T. J. Scott, who reported as follows:—

STATEMENT OF RECEIPTS, PAYMENTS AND BALANCES:

1st April, 1939, to 31st May, 1939.

	£	s.	d.
Commencing Balance	116376	4	2
Less 1938/39 Cheques since issued	665	15	4
	115710	8	10
Receipts (Appendix, page 1):—			
Previously Reported	98151	2	4
Now Reported	152820	19	8
	250972	2	0
	366682	10	10
Payments (Appendix, page 2):—			
Previously Reported	65953	3	8
Now Reported	129336	3	7
	195289	7	3
Less Cheques Cancelled	1001	18	11
	194287	8	4
Balance at 31st May, 1939, (Appendix, page 3)	£172395	2	6

2.—RATE COLLECTION ACCOUNT (Appendix, page 4):

Rate Collection 1st April, 1939, to 31st May, 1939.

	Arrears of Rates and Costs.			Current Rate.			Total.		
	£	s.	d.	£	s.	d.	£	s.	d.
Previously reported	2544	19	3	34353	13	4	36898	12	7
Now reported	2031	3	6	110981	9	2	113012	12	8
	<u>£4576</u>	<u>2</u>	<u>9</u>	<u>£145335</u>	<u>2</u>	<u>6</u>	<u>£149911</u>	<u>5</u>	<u>3</u>

3.—STATEMENT OF EXPENDITURE AND INCOME ON RATE FUND ACCOUNTS (Appendix, pages 5/6):

The Borough Treasurer submitted a statement of expenditure and income for the period from 1st April, 1939, to 31st May, 1939.

4.—ACCOUNTS EXAMINED AND APPROVED FOR PAYMENT (Appendix, page 7):

List of Accounts Submitted to Rota.

REPORTED: That pursuant to the Finance and General Purposes Committee Instruction No. 2 and Resolutions of the Council, the following accounts as listed in the Expenditure Journal had been examined and approved; that in view of the urgency of such accounts the necessary Pay Orders had been prepared and signed as authority to the Borough Treasurer to draw cheques, and that copies of such Pay Orders had been forwarded to the Corporation's Bankers with instructions to honour only such cheques as appeared in such Pay Orders:—

List No.	Date Examined.	Examined by.	General A/c.		Loans Pool.	
			£	s. d.	£	s. d.
—	Previously Reported (Per Minutes, page 571)	—	128734	4 8	601	18 11
—	Per Bank Account (Appendix, page 3)	—	£129336	3 7		
—	Previously Reported (Per Minutes, page 871)	—	33791	6 7	—	—
296—297	19th June, 1939	Councillor L. Hirshfield	432	18 6	—	—
28—31	19th June, 1939	Councillor L. Hirshfield	121806	12 4	—	—
32	19th June, 1939	Councillor L. Hirshfield	28633	6 8	—	—
33	19th June, 1939	Councillor L. Hirshfield	—	—	50282	9 5
298	26th June, 1939	Councillor P. Lightfoot	673	9 10	—	—
34—37	26th June, 1939	Councillor P. Lightfoot	21066	7 6	—	—
299—300	3rd July, 1939	Councillor A. A. Naar	2231	16 7	—	—
38—43	3rd July, 1939	Councillor A. A. Naar	9188	16 11	—	—
301—303	10th July, 1939	Councillor T. J. Scott	1211	1 0	—	—
44—46	10th July, 1939	Councillor T. J. Scott	8633	5 8	—	—
			<u>£227669</u>	<u>1 7 50282</u>	<u>9 5</u>	

Noted.

5.—STATISTICAL RETURNS:

Statistical returns, details of which appear in the appendix to this report, were submitted and **noted**.

6.—REQUISITION:

A requisition for general stationery amounting to £227 7s. 9d. was submitted and **approved**.

7.—LOAN SANCTIONS:

It was reported that the Minister of Health had issued the following loan sanctions:—

Date.	Amount. £	Purpose.	Period. Years.
13/6/39	8,850	Edgwarebury Lane Improvement (Station Road to Edgware Way)	15
		Broadfields Avenue School.—	
19/6/39	25,824	Erection	40
19/6/39	1,184	Heating	15

RESOLVED TO RECOMMEND—That the Borough Treasurer be authorised to raise loans against such sanctions as and when required.

STAFF.

8.—ABSENCE:

It was reported that ten members of the staff had been absent owing to illness since the last meeting of the Committee. **Noted.**

9.—INCREMENTS:

The Committee have considered the recommendations of the Chief Officers in cases due for scale increments for the period to the 1st September next, together with information as to service, grade, present salary and the amount of increment due according to scale.

RESOLVED TO RECOMMEND—That scale increments be awarded in all cases recommended by the Chief Officers and enumerated in the Borough Treasurer's report.

10.—BOROUGH TREASURER'S DEPARTMENT:

It has been reported that Mr. J. Henderson, with the consent of His Worship the Mayor, has been granted 12 weeks leave of absence without pay in order to undergo training in the Royal Air Force. It at the end of that period he is found satisfactory it is his intention to take up service as an Observer.

RESOLVED TO RECOMMEND—That the action taken be approved.

11.—BOROUGH SURVEYOR'S DEPARTMENT:

Mr. W. K. Ferguson, Architectural Assistant in the Borough Surveyor's Department, has completed two years service on the temporary staff and has been recommended for appointment to the permanent staff in Grade C.2 at a commencing salary of £300 per annum, to be £320 as from 1st April, 1940.

RESOLVED TO RECOMMEND—That Mr. W. K. Ferguson be appointed to the permanent staff in Grade C.2 at a commencing salary of £300 per annum, to be £320 as from the 1st April, 1940.

12.—PROPOSED JOINT COMMITTEE:

The Committee have given consideration to an application from the Hendon Branch of the National Association of Local Government Officers calling attention to the provisions of the scheme of the Middlesex Whitley Council in the above matter and asking for consideration to be given to the question of the establishment of a Joint Committee.

Total.
£ s. d.
898 12 7
012 12 8
011 5 3

ACCOUNTS
come for the

(dix, page 7):

s Committee
listed in the
urgency of
as authority
Orders had
only such

e. Loans Pool.
d. £ s. d.
8 601 15 11

6 3 7

7 ---
6 ---
4 ---
8 ---
50282 9 3
0 ---
5 ---
7 ---
1 ---
9 ---

50282 9 5
Noted.

port. were

mitted and

After careful consideration of the whole matter and having reviewed the objects of the proposed Joint Committee, the Committee feel that, in view of the facilities now available to the staff and the satisfactory manner in which staff questions are dealt with, no useful purpose would be served by the constitution of the Joint Committee, and they accordingly

RECOMMEND—That no action be taken.

13.—SUPERANNUATION FUNDS:

The Committee have considered reports from the Borough Treasurer on routine and other matters arising out of the administration of the above Acts and have signified agreement with, or have duly noted, the reports on the following matters:—

Local Government Superannuation Acts, 1937/9.

- (i) *Servants—Class A*—Verification of ages in certain cases (F. & G.P.C., 12/6/39—15) proceeding. 19 cases have yet to be completed.
- (ii) *Transfer Values (£11 15s. 3d.)*—From the Salford Town Council in respect of Miss M. L. Anderson, Temporary Staff Nurse, Isolation Hospital, entitling to reckon as non-contributory service 1 year 2 months.
- (£125 5s. 3d.)—Payable to the Kent County Council in respect of Mr. G. L. Feltham.

(iii) *Isolation Hospital—Staff Appointments:—*

Permanent Staff.				Date.
Miss A. Fitzpatrick	Sister	23/6/39.
Miss M. W. Kite	Staff Nurse	16/6/39.
Temporary Staff.				
Miss S. G. W. Greene	Probationer	26/6/39.

- (iv) *Nurses, Midwives, and Health Visitors*—The application to specific members of the staff of Section 16 of the Act of 1937 relating to retirement at the age of 60.
- (v) *Scottish Service*—Amendments to schedules consequent on the Local Government Superannuation Act, 1939, under which service with a Scottish Local Authority is now reckoned for superannuation.
- (vi) *Contributory Employees*—Approval of schedules with respect to
- (1) certain of the employees who have entered the service of the Council since the 8th May, 1939, and those who have attained age 18 years since that date to whom it is necessary to issue a notification that they are contributing employees within the meaning of the 1937 Act.
 - (2) certain employees to whom it is necessary to issue further particulars of service which were not available at the date of the original notification.

Fire Brigade Pensions Act, 1925.

- (vii) *Refund of Contributions (£6 12s. 1d.)*—To Fireman M. D. Hughes upon resignation, thus terminating the Council's liability.

PRIVATE STREET IMPROVEMENTS.

14.—AGREEMENTS:

It was reported that nine agreements to pay private improvement expenses by instalments had been completed since the last meeting.

15.—PRIVATE WORKS:

The Borough Surveyor submitted the following statement as to agreements for the execution of private works:—

	Date of Agreement. 1939.	Amount of Deposit. £
Philip Green & Partners—Crossing, Waverley Grove, Hendon	12th June	28
J. Mowlem & Co.—Connections, Edgware Road, Hendon	13th June	25
Berney & Marks—2 Crossings, The Quadrant, Hendon	14th June	50
W. Lawrence & Son, Ltd.—Connection, The Ridgeway, Mill Hill	22nd June,	25
C. E. Matthews—Connection, Hankins Lane, Mill Hill	27th June	20
Berney & Marks—Laying kerb to accommodation Road, The Quadrant, Hendon	27th June	55
Buckingham & Sons—Connections, Finchley Lane, Hendon	7th July	25

INSURANCE.

16.—CLAIMS:

The following statement was submitted and noted:—

Third Party, Driving, etc., Accidents:—

No. of cases in hands of Insurance Companies brought forward	14
No. of new cases	25
	39
No. of cases settled or otherwise disposed of	21
	18
Still outstanding	18
Claims paid by Insurance Companies	£7 7 9

Workmen's Compensation Cases:—

No. of cases on books, 12/6/39	4
No. of new cases	7
	11
No. of cases taken out of compensation or otherwise disposed of	7
	4
No. of cases now under compensation or pending	4

17.—FUND:

RESOLVED TO RECOMMEND.—That the following additional risks be carried by the Council's Fund:—

Description.	Value for insurance. £	To be insured with Co. £	To be carried by Fund. £	Commenc- ing Date.	Annual Premium. £ s. d.
"Fenella," The Burroughs— Contents owned by the Corporation	200	—	200	1/6/39	3 0
"Derby House"—Building.....	2500	—	2500	24/6/39	1 17 6
Dollis Junior and Infants' School—School Build- ings, etc.	23200	15700	7500	22/6/39	5 12 6
	<u>£25900</u>	<u>£15700</u>	<u>£10200</u>		<u>£7 13 0</u>

LOANS.**18.—NEW LOANS:**

In connection with item 27 of the Committee's report of the 12th June, it has now been reported that the balance, £25,000, of the loans reported as negotiated would now be obtained from the same source, The Sun Life Assurance Company of Canada, on the same terms.

The Borough Treasurer has also reported arrangements to take up a further loan of £15,000 for a period of 30 years certain at 3½ per cent. repayable by fixed half-yearly instalments.

RESOLVED TO RECOMMEND—

- (1) That the action taken be approved;
- (2) That the Corporate Seal be affixed to the mortgage with The Sun Life Assurance Company in respect of loans amounting to £50,000.
- (3) That authority be given to complete negotiations in respect of the proposed loan of £15,000, and that the Corporate Seal be affixed to the mortgage in due course.

19.—SHORT TERM LOANS:

At the present time there are 25 loans to the Corporation amounting to £17,315 on 3 months or 6 months notice either side at 3 per cent. per annum.

One lender of a substantial portion of the amount invested has asked for consideration to be given to the question of the rate of interest, and having regard to prevailing rates, the Committee

RESOLVED TO RECOMMEND—That all lenders concerned in the sum of £17,315 be offered a rate of interest of 3½ per cent. as from the 1st October, 1939, provided they agree to renew for a period of five years from that date.

20.—CAPITAL WORKS:

The Borough Treasurer submitted the following statement:—

Contract.	Original estimated cost. £	Amount of Tender. £	Actual Cost. £
Private Street Improvements:—			
Devonshire Road (part)	3324	3157	3128
Devonshire Crescent.....	1607	1487	1392
Aberdare Gardens	1545	1438	1351
Osborn Gardens	972	910	836
	<hr/>	<hr/>	<hr/>
	£7448	£6992	£6707
	<hr/>	<hr/>	<hr/>

Noted.

CORPORATION LANDS.**21.—SURPLUS (SEWAGE DISPOSAL) LAND—SOUTH BRENT:***Site—Elementary Schools.*

The Committee have considered the application from the Education Committee (W.S/C., 20/6/39—2) regarding the allocation of 10.5 acres of land for the purposes of Elementary Schools.

The Council by resolution of the 31/1/38 allocated 8 acres for two schools in the vicinity, but it has now been reported that the proposed 10.5 acres will prove a more satisfactory and economical site.

RESOLVED TO RECOMMEND—

- (1) **That 10.5 acres in the position indicated on the plan submitted to the Education Committee be allocated to educational purposes, at a price to be approved by the District Valuer;**
- (2) **That application be made for the approval of the Board of Education to the site and to the Minister of Health for consent to appropriation;**
- (3) **That any resolution of the Council inconsistent herewith be varied accordingly.**

22.—AIR RAID PRECAUTIONS AND CIVIL DEFENCE SERVICES:

Consideration has been given to a communication, dated 4th July from the County Council with regard to policy in relation to lands used for the erection of buildings for the above services. The County Council remind Local Authorities that where expenditure is to be defrayed out of a loan the sanction to borrow will only be given to the County Council, and it, therefore, follows that the County Council must take an appropriate interest in the site on which the works have been carried out. Where the land in question is already the freehold property of the Local Authority the site should, except as mentioned below, be conveyed to the County Council. Where, however, such a conveyance would cause practical difficulties, *e.g.*, if the expenditure has been incurred by the Local Authority in enlarging a Town Hall or other building of its own, then in these cases a lease for a long term of years must be granted to the County Council.

The County Council further remind Local Authorities that when premises cease to be used for the above-mentioned purposes, they are required to account to the Government in respect of the grant which has been received. The Lord Privy Seal has intimated that where the land is already vested in the Local Authority no pecuniary consideration can be paid by the County Council in respect of the conveyance and only a nominal rent on the grant of a lease. Provision would, however, be made if so desired for the Local Authority to have an option to re-purchase the property (or to obtain a surrender of

Annual
Premium.
£ s. d.

3 0

1 17 6

5 12 6

£7 13 0

it has now
would now
nada, on thether loan of
half-yearly

a Sun Life

e proposed
mortgage in

£17,315 on

considera-
prevailingof £17,315
1939, pro-

the lease) when the premises were no longer required for the purposes in question. The terms on which the option could be exerciseable would be such as the appropriate Government Department might approve, but site value would be ignored, as no consideration is given for this.

The remaining exception arises where the expenditure incurred is less than £1,000 so that a loan would not be raised. In these cases the Local Authority would be required to enter into an agreement with the County Council providing for the necessary financial adjustment when the premises cease to be required for these purposes.

The recent construction of a gas chamber at "Ravensfield" is affected by the proposals in the preceding paragraph, and the County Council have enquired whether the Council are prepared to enter into a financial agreement in the matter.

Where land has to be purchased or leased and is not already in the ownership of the Local Authority, the conveyance or lease will be taken directly by the County Council.

In connection with the policy of the County Council as outlined above, a letter has been received from the Council of the Borough of Southall taking strong exception to the requirement that they should convey or let on long lease to the County Council, free of cost, properties which they have purchased for other than Air Raid Precautions purposes. The Southall Council state that the position appears to be that the grant in aid of Air Raid Precautions expenditure is in this instance being used arbitrarily to secure the transference to the control of His Majesty's Government, free of cost, of land which has been purchased at the expense of the inhabitants of county districts, and additionally that if eventually the various county districts are undesirous of taking over the buildings erected on sites which they have provided they may virtually be held to ransom for the return of their own property.

The Committee have also considered a further communication from the County Council in connection with the use of Corporation lands for the erection of multi-purpose buildings (F. & G.P.C., 12/6/39—35). It will be remembered that the Council agreed—

"That an intimation be given that the Town Council will be prepared, subject to the consent of the Ministry of Health, to grant leases on Corporation lands for periods and at rentals to be agreed, subject to such restrictive covenants as the circumstances in each case may warrant."

To implement the resolution it was suggested to the County Council that the sites for the three multi-purpose buildings be leased by the Borough Council to the County Council for a period of 21 years at annual rentals representing the proportionate annual loan charges which the Borough Council has been called upon to pay in respect of the areas to be leased. At the end of the term the buildings should become the property of this Council, the Council taking over the outstanding loan charges in respect of the buildings for the balance of the period of the building loan. The amounts payable would not be considerable, probably under £15 per annum per site.

In reply, the County Council to some extent reiterates the policy outlined in the letter of the 4th July and intimates that the suggested term of 21 years is not acceptable. The Minister of Health is not prepared to sanction loans to the County Council for the erection of buildings unless such buildings become the property of the County Council either indefinitely (as is the case where the freehold is vested in the Council) or for a substantial term of years.

Having regard to the heavy expenditure involved in connection with these buildings, the County Council would be of opinion that the freehold should be vested in it but would give the Council the right to purchase the buildings if at any time they were no longer required for A.R.P. or civil defence purposes at a price to be determined on the basis approved by the appropriate Government Department and as no consideration would be paid for the site, this value would be ignored on a re-purchase. If for some special reason a conveyance of the freehold cannot be arranged, the County Council

might not object to a long lease (60 year minimum) at a nominal rent and containing a provision for earlier determination if the buildings were no longer used for the above-mentioned purposes and the Council desired to purchase them on the foregoing basis. Failing this, the County Council would require the right to use the buildings for the remainder of the term for any reasonable purpose, if it did not wish to surrender the lease.

In regard to the reference to restrictive covenants, the County Council would not be prepared to enter into any (whether it takes a conveyance or a lease) which would preclude the use of the buildings for A.R.P. or civil defence purposes or in the event of the Corporation not exercising the rights referred to when the buildings were no longer required for such purposes which would preclude their use for any other reasonable object should the County Council so require.

It will be gathered from the foregoing that the County Council would not be disposed to proceed on the lines indicated in the Council's letter and they ask for any further observations the Council may care to make which would be considered by the County Air Raid Precautions Committee at its meeting on the 11th July.

The Committee understand that the plans for the multi-purpose buildings have been approved by the County Council and the Home Office and that the Borough Surveyor is proceeding with detailed drawing, etc., as far as practicable with a view to obtaining tenders. It is a matter of considerable importance that the negotiations on the question of the sites should not delay progress with the provision of the required buildings. Whilst the County Council should be so informed and reminded of the possibility of their holding up progress the Committee are unable to fall in with the policy of the County Council in relation to sites.

RESOLVED TO RECOMMEND—That the County Council be informed that the Town Council are prepared to grant leases at nominal rentals for the periods of the respective building loan sanctions, or alternatively that upon the issue of the loan sanction to the Town Council, and subject to the payment of loan charges by the County Council during the period of use of the buildings for A.R.P. purposes, the Town Council will be prepared to grant the use of sites and to take over the buildings, when they cease to be so occupied, with the liability for outstanding charges.

23.—CLITTERHOUSE PLAYING FIELDS:

An enquiry has been considered from Messrs. Biscoe & Stanton, Surveyors to the London Diocesan Fund, as to whether it would be possible for the Council to provide a site in the neighbourhood of the Clitterhouse Estate and the Golders Green Estate for the purpose of erecting a Church and suggesting a piece of land with about 40 feet frontage to Claremont Road and a depth of 130 feet between Clitterhouse Farm and the entrance to the park nearest Clitterhouse School.

RESOLVED TO RECOMMEND—That further enquiries be made into the application and a report submitted at the next meeting.

24.—THE FAIRWAY, MILL HILL:

Mr. F. W. Westlake of No. 128, Watling Avenue, seeks permission to rent a piece of land fronting Barnet Way adjacent to the road known as The Fairway, for the purposes of a refreshment hut. The site is unsuitable and the use of the ground for this purpose would be detrimental to the amenities and safety on the road.

RESOLVED TO RECOMMEND—That Mr. F. W. Westlake be informed that the Council are unable to entertain his application.

25.—COMMUNITY CENTRE—WATLING:

The Committee have considered the reference from the Education Committee (S.M. S/C., 20/6/39) relating to the enquiry of the Middlesex County Council as to whether the Town Council would be prepared to make a contribution towards the cost of the extension of the Community Centre on the Watling Estate, estimated to amount to £11,000.

The Council, 30/1/39 (F. & G.P.C., 23/1/39—44), decided that the County Council should be asked to accept responsibility for the provision of such Community Centres as may be necessary in the Borough under powers conferred upon them as the Local Higher Education Authority, and in view of the financial implications and grant available to the County Council under the Education Act, 1921, as compared with the problematical grant which would be available to the Town Council under the Physical Training and Recreation Act, 1937, the Committee

RECOMMEND—That the County Council be informed that the Town Council prefer them to accept full responsibility under the provision of Section 86 of the Education Act, 1921, as amended.

26.—FOOD AND DRUGS ACT, 1938:

A letter has been submitted from the Ministry of Health referring to the application made by the County Council for a direction under proviso (a) to Section 64 of the Food and Drugs Act, 1938, that they shall continue to be the Food and Drugs Authority for the County of Middlesex on and after the 1st October next as respects the districts of those Local Authorities who, but for such a direction, would become Food and Drugs Authorities, and intimating that after consideration of the representations he had decided that in the absence of such a direction the area which would remain to be administered by the County Council as a Food and Drugs Authority would be rendered inconvenient in size, shape and situation for the efficient performance of the County Council's duties.

In the circumstances an instrument has been issued directing the County Council to exercise the powers and duties under the Food and Drugs Act, 1938, in the Borough of Hendon. **Noted.**

27.—COLNE VALLEY WATER BILL:

The Committee, 23/1/39, authorised negotiations to continue on the above Bill which, at that time, mainly concerned an alternative site for the proposed water tower. It was subsequently found that the promoters regarded the Nan Clark's Lane site as preferable for their purposes, and in the circumstances the Company were requested to satisfy the Council on the questions of height of the water tower, architecture and reinstatement of Nan Clark's Lane.

Lengthy negotiations and interviews followed, and it became necessary to lodge a petition in the House of Lords. Since this action was taken the promoters have met all the points and an amendment to the Bill will reduce the potential height of the tower, 105 feet to 77 feet at the top water level. A clause for the protection of the Corporation to secure the restoration of Nan Clark's Lane on completion of works has also been inserted in the Bill, and as regards architectural design of the service reservoir, it is proposed to rely on correspondence in which the Company agrees to retain Mr. Clough Williams-Ellis, F.R.I.B.A., to advise on design and to minimise any adverse effect on the amenities of the neighbourhood.

In view of the settlement, the petition against the Bill was withdrawn with the consent of the Mayor. **Noted.**

28.—LAND—GREAT NORTH WAY:

The Town Clerk reported the result of the High Court Action, Cowan v. the Hendon Borough Council, heard before Mr. Justice Farwell on the 20th and 21st June. Mr. Cowan's action has been dismissed and costs awarded to the Council.

Noted with satisfaction.

29.—PAWNBROKER'S LICENCE—RENEWAL:

An application has been submitted from Harvey & Thompson Limited for the renewal of the Pawnbroker's Licence in respect of 156, The Broadway, Burnt Oak, for a period of one year to the 31st July, 1940. A satisfactory report from the Police has been received.

RESOLVED TO RECOMMEND—That the licence be renewed for a period of one year to the 31st July, 1940.

30.—LONDON SAFETY FIRST COUNCIL:

The Committee have considered the annual application of the above Council for the renewal of the subscription, and

RESOLVED TO RECOMMEND—That the Council's annual contribution of the sum of £10 10s. 0d. in respect of the year ending 31st October, 1939, be approved.

TRAVELLING FACILITIES.

31.—INCREASE OF FARES:

The Committee have received and duly **noted** the following representation from the Hendon Ratepayers' Association:—

"The recent increase in fares by the London Passenger Transport Board which has been greeted with such a storm of protest throughout the country lends emphasis to the point so often raised by this Association that this Monopoly is not giving its public a 'square deal.' In spite of the new rolling stock which has been introduced it is still difficult to get a seat on the Tube during the peak hours and my Association hope that the Hendon Borough Council, as representing the ratepayers in Hendon, will not let the opportunity pass without reminding the Board of its duty to the public in this respect."

32.—FARE STAGE—BUS ROUTE 240:

It has been reported that the Mill Hill Ratepayers' & Residents' Association and the United Kingdom Optical Company have made application to the London Passenger Transport Board for an alteration of the fare stage from Partingdale Lane to Engel Park and that the Board are prepared to approve the alteration on an assurance from the Local Authority and the Ratepayers' Association that the proposal will not be unpopular with the residents.

It is understood that the alteration of the fare stage is likely to have a beneficial effect on the majority of the people using the 'bus service in the area, and in the circumstances, the Committee

RECOMMEND—That the Mill Hill Ratepayers' & Residents' Association be informed that the Council are in agreement with the proposal.

33.—COUNTY PRECEPT:

A letter from the Hendon Ratepayers' Association enclosing a copy of a report drawn up by the Federation of Ratepayers' Associations, Middlesex, on the County Council's budget of 1939/40 was submitted and **noted**.

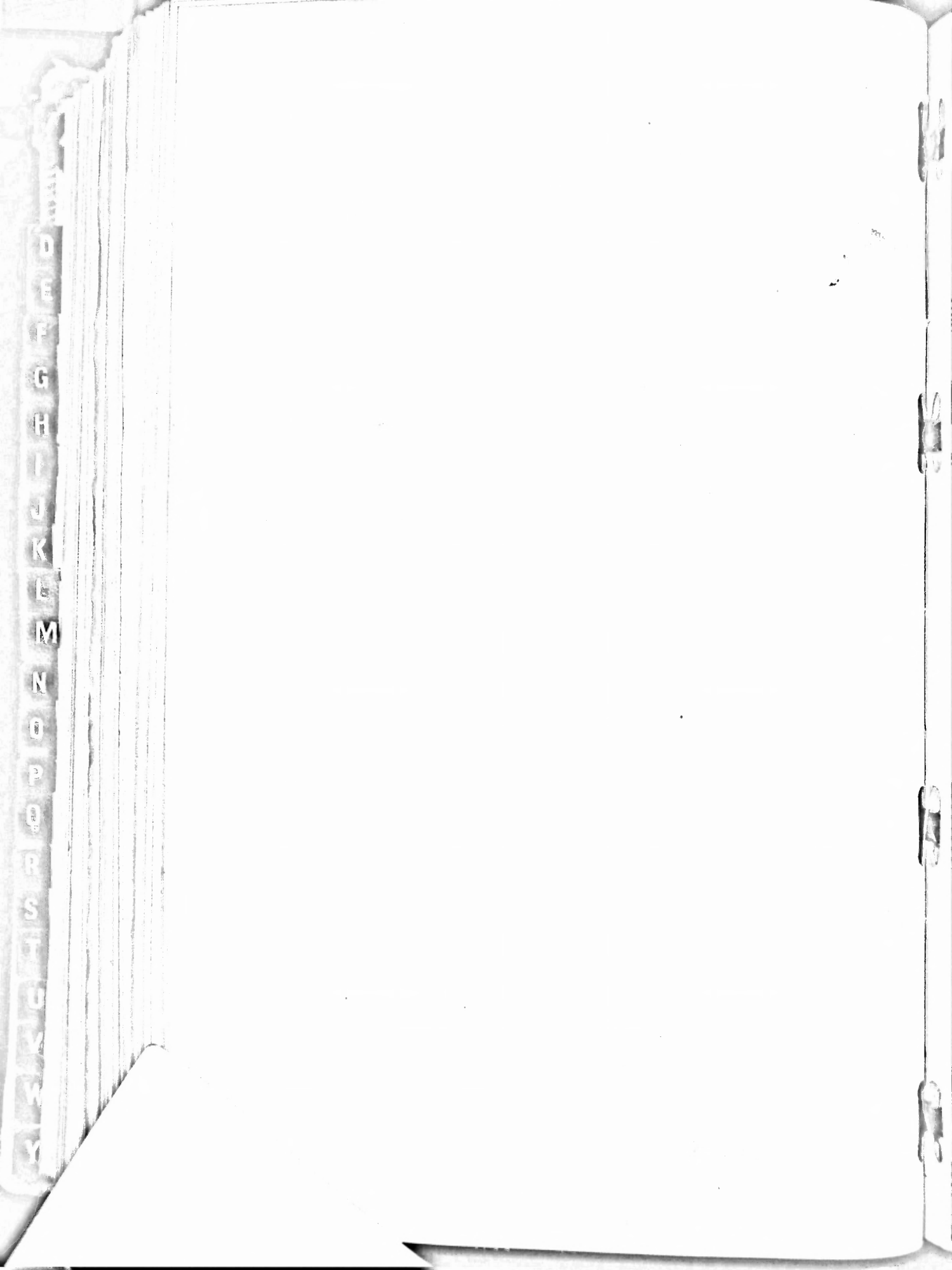

A
B
C
D
E
F
G
H
I
J
K
L
M
N
O
P
Q
R
S
T
U
V
W
X
Y
Z

APPENDIX

TO

Report of Finance and General Purposes Committee,

10th July, 1939.

Page	
1/2.	Statement of Receipts and Payments.
3.	Statement of Bank Accounts and Balances.
4.	Rate Collection Account and Comparative Statement.
4.	Statement of Rateable Values.
5/6.	Expenditure and Income on Rate Fund Accounts.
7.	Accounts Examined and Approved.
7.	Requisitions submitted to Committees.
	Statistical Returns:—
8.	Education Services.
8.	School Medical Services.
9.	Maternity and Child Welfare Services.
9.	Hendon Borough (Nursing Associations) Scheme, 1935.
10.	General Health Statistics.
11.	Fire Brigade and Ambulance.
11.	Refuse Destructor.
11.	Small Dwellings Acquisition Acts.
12.	Housing Statistics.
13/14.	Library Statistics.
15.	Public Parks.
15.	Public Lavatories.
15.	Public Slipper Baths.
16.	Open Air Swimming Baths.
17.	Wages Return.
18.	Loan Debt Statement.
19.	Loan Sanctions.
19.	Payments to Contractors under Engineer's Certificates.
20/21.	Contracts, etc. let.

(1)

1.—RECEIPTS AND
1st April, 1939

RECEIPTS.			Receipts now Reported.	Receipts Previously Reported.	Total to 31/5/39.			
	£	s. d.	£	s. d.	£	s. d.		
Revenue Accounts (General).....			121164	1 9	55805	11 2	176969	12 11
Private Street Improvements			2437	12 10	1632	12 4	4070	5 2
			123601	14 7	57438	3 6	181039	18 1
Elementary Education Accounts		19521		3 8				
Higher Education Accounts				38 16				
Youth Organisation Accounts		281		15 2				
			19841	15 4	20067	9 0	39909	4 4
Capital Accounts (General)				10 15				
Capital Accounts (Education)								
				10 15			10 15	
Small Dwellings Act Accounts			808	8 9	879	1 9	1687	10 6
Superannuation Fund Accounts			1194	16 3	1075	1 10	2269	18 1
Loans Pool Account					10000	0 0	10000	0 0
Receipts 1938/40 Accounts			£145457	10 0	89459	16 1	234917	6 1
ARREARS—1938/39.								
Revenue Accounts (General).....			7105	12 6	8215	4 4	15320	16 10
Private Street Improvements								
			7105	12 6	8215	4 4	15320	16 10
Elementary Education Accounts		18		3 0				
Higher Education Accounts		133		17 8				
Youth Organisation Accounts								
			152	0 8	466	5 9	618	6 5
Capital Accounts (General)								
Capital Accounts (Education)								
Small Dwellings Act Accounts								
Superannuation Fund Accounts			105	16 6	9	16 2	115	12 8
Loans Pool Account								
Receipts 1938/39 Accounts			£7363	9 8	8691	6 3	16054	15 11
TOTAL RECEIPTS			£152820	19 8	98151	2 4	250972	2 0
Cancelled Cheques:—								
General Cash Book folio 12					500	0 0		
Loans Pool Cash Book folio 4					501	18 11		
							1001	18 11
Nett Balance in Hand, 1st April, 1939:—								
Per General Cash Book folio 12							93638	0 9
Per Loans Pool Cash Book folio 2							22738	3 5
							£368350	5 1

DEBITS AND
t April, 1939

Total
to
31/5/39.
£ s. d.
170969 12 11
4070 5 2
181039 18 1

39909 4 4

10 15 1
1687 10 6
2269 18 1
10000 0 0
234917 6 1

15320 16 10
— — —
15320 16 10

618 6 5

— — —
— — —
115 12 8
— — —
16054 15 11
250972 2 0

1001 18 11
93638 0 9
22738 3 5
£368350 5 1

PAYMENTS ACCOUNT.

—31st May, 1939.

PAYMENTS.		Payments now Reported.	Payments Previously Reported.	Total to 31/5/39.
		£ s. d.	£ s. d.	£ s. d.
Revenue Accounts (General).....	— — —	91899 18 0	33850 9 1	125750 7 1
Private Street Improvements.....	— — —	3365 2 7	92 2 3	3457 4 10
		95265 0 7	33942 11 4	129207 11 11
Elementary Education Accounts	— — — 13804 17 2			
Higher Education Accounts	— — — 197 15 5			
Youth Organisation Accounts	— — — 4 0 3			
		14006 12 10	13201 16 4	27208 9 2
Capital Accounts (General)	— — — 4827 18 5			
Capital Accounts (Education)	— — — 1586 5 8			
		6414 4 1	9015 14 3	15429 18 4
Small Dwellings Act Accounts	— — —	1 8 0	— — —	1 8 0
Superannuation Fund Accounts	— — —	244 1 8	147 0 6	391 2 2
Loans Pool Account	— — —	601 18 11	31 14 5	633 13 4
Payments 1939/40 Accounts	— — —	£116533 6 1	56338 16 10	172872 2 11
CREDITORS—1938/39.				
Revenue Accounts (General).....	— — —	8550 15 6	6535 4 6	15086 0 0
Private Street Improvements	— — —	193 13 7	2 9 10	196 3 5
		8744 9 1	6537 14 4	15282 3 5
Elementary Education Accounts	— — — 2326 13 1			
Higher Education Accounts	— — — 9 0 6			
Youth Organisation Accounts	— — — 30 11 4			
		2366 4 11	2303 1 4	4669 6 3
Capital Accounts (General)	— — — 77 11 2			
Capital Accounts (Education)	— — — 1593 12 2			
		1671 3 4	773 1 6	2444 4 10
Small Dwellings Act Accounts	— — —	17 9 0	— — —	17 9 0
Superannuation Fund Accounts	— — —	3 11 2	9 8	4 0 10
Loans Pool Account	— — —	— — —	— — —	— — —
Payments 1938/39 Accounts	— — —	£12802 17 6	9614 6 10	22417 4 4
TOTAL PAYMENTS	— — —	£129336 3 7	65953 3 8	195289 7 3
Cheques written back:—				
General Cash Book folio 12	— — —			665 15 4
Nett Balance in Hand, 31st May, 1939:—				
Per Bank Account page 3	— — —			172395 2 6
				£368350 5 1

2.—BANK ACCOUNTS AND BALANCES:

(3)

RECEIPTS.				PAYMENTS.			
1st April, 1939, to 31st May, 1939.				1st April, 1939, to 31st May, 1939.			
Balances, 30th April, 1939.		Receipts now reported.		Payments now reported.		Balances, 31st May, 1939.	
In Hand.	Overdrawn.	Transfers In.	Total.	Cheques Written Back.	In Hand.	Overdrawn.	Total.
£ s. d.	£ s. d.	£ s. d.	£ s. d.	£ s. d.	£ s. d.	£ s. d.	£ s. d.
80181 16 1	— — —	— — —	130707 7 1	— — —	106879 13 6	— — —	210889 3 2
11594 0 0	— — —	— — —	19993 16 0	— — —	15514 18 3	— — —	31887 16 0
4614 10 11	— — —	— — —	10 15 1	— — —	— — —	— — —	— — —
3590 7 7	— — —	— — —	808 8 9	— — —	— — —	3460 1 5	4635 6 0
15421 3 11	— — —	— — —	1300 12 9	— — —	— — —	— — —	4398 16 4
115701 18 6	— — —	— — —	152820 19 8	— — —	— — —	— — —	16721 16 8
32706 9 0	— — —	— — —	— — —	— — —	— — —	— — —	268522 18 2
£148408 7 6	— — —	— — —	152820 19 8	— — —	— — —	— — —	33208 7 11
					175855 3 11	3460 1 5	301731 6 1

BANK RECONCILIATION ACCOUNT.		£	s.	d.
Balance Per Bank Certificate—31st May, 1939		230303	8	1
Deduct:—				
Wages and Urgent Payments Account	£ s. d.	6084	0	4
Returned Cheques Account	£ s. d.	572	3	2
Bank Charges Account	£ s. d.	60	0	0
		632	3	2
		5451	17	2
Less Unpresented Cheques		224851	10	11
		56772	5	11
Add In Hands of Cashier		108079	5	0
		4315	17	6
Balance as above		£172305	2	6

(4)

RATE AND COSTS COLLECTION ACCOUNT—YEAR ENDING 31st MARCH, 1940:
(Two Months to 31st May, 1939.)

Debits.		£	s.	d.	Credits.		£	s.	d.		
Arrears of Rate, 31st March, 1939		11415	12	0	Cash Collected to 31st May, 1939:—						
Rate made 3rd April, 1939, at 11/0d. in the £		1060999	10	0	Previously Reported		36898	12	7		
Government Contribution in lieu of Rates		18230	6	0	Now Reported:—	£	s.	d.			
Supplementals, to 31st May, 1939		273	9	4	Arrears and Costs		2031	3	6		
Rates Costs:—	£	s.	d.		Current Rates		110981	9	2		
Arrears		306	19	0					113012	12	8
Current		10	1	3					149911	5	3
				317	0	3					
					Balances Due (subject to allowances):—						
					Arrears and Costs		7156	9	6		
					Current Rates		934168	2	7		
									941324	12	1
									£1091235	17	4
									£1091235	17	4

Percentages Collected (Including Costs).

Previously Reported	3.38%
Now Reported	10.36%
Percentage of Total Debit	13.74%

Collected to 30th June, 1939:—£320356 18s. 4d.

RATE COLLECTION—COMPARATIVE STATEMENT.

As at	General Rate 1936-37		General Rate 1937-38		General Rate 1938-39		General Rate 1939-40	
	Collected	Percentage	Collected	Percentage	Collected	Percentage	Collected	Percentage
	£		£		£		£	
30th April	9,266	1.02	25,435	2.69	37,154	3.65	56,843	3.38
31st May	142,920	15.65	145,728	15.39	169,034	16.62	149,803	13.73
30th June	291,597	31.89	302,362	31.91	310,287	31.93		
31st July	393,745	40.36	422,860	44.62	445,403	43.67		
31st August	412,227	46.15	442,316	46.59	475,830	46.52		
30th September ..	430,500	47.59	459,989	48.07	488,254	47.65		
31st October	501,552	54.18	544,446	56.97	586,148	57.20		
30th November ..	622,737	67.27	645,147	67.31	660,410	67.14		
31st December ..	731,462	78.56	760,032	79.29	816,788	79.23		
31st January	845,454	90.76	879,876	91.76	946,007	90.73		
28th February ..	870,588	93.25	904,444	94.21	967,249	93.79		
31st March	883,671	94.32	916,339	95.23	981,042	94.93		

STATEMENT OF RATEABLE VALUES.

RATEABLE VALUES.	EDGWARE.		HENDON.		TOTAL.
	£	£	£	£	
UNREDUCED RATEABLE VALUE (excluding Agricultural Land and Farm Buildings).		202760		1820851	2023611
Former Rateable Value of Land and Buildings.		452		1848	2300
Total Unreduced Rateable Value.		£203212		£1822699	£2025911
REDUCED RATEABLE VALUE.					
GENERAL HEREDITAMENTS.		199909		1740839	1940748
TITHES. Land covered with water, and land used as Railway other than Freight Transport.		279		3259	3538
INDUSTRIAL HEREDITAMENTS.					
Industrial Purposes	373		15964		
Non-Industrial	81	454	6709		
FREIGHT TRANSPORT HEREDITAMENTS.					
Running Lines	229		1277		
Station Buildings, etc.	18		244		
Other Land and Buildings	—	247	—	1521	1768
Reduced Value 30th June, 1939.		£200889		£1768292	£1969181
Reduced Value 1st April, 1939.		£199015		£1763221	£1962236
Increase to Date.		£1874		£5071	£6945

Add In Hands of Cashier 168079 5 0
 Balance as above 4315 17 6
 £172295 2 6

STATEMENT OF EXPENDITURE AND

1st April, 1939 to

EXPENDITURE.	Amount Previously Reported.		Amount now Reported.		Total.	
	£	s. d.	£	s. d.	£	s. d.
Parks, Pleasure Grounds and Open Spaces	1842	13 7	2094	16 10	4837	10 5
General Public Health Services	145	0 10	174	9 0	319	9 10
Hospital, Maternity and Child Welfare, and Midwifery	375	10 3	452	3 1	827	13 4
County and Trunk Roads	1444	7 7	1596	6 1	3040	13 8
Local Roads	1977	8 10	3401	9 6	5378	18 4
Public Lighting	17	19 6	8	12 9	26	12 3
Traffic Control	16	4 1	28	10 4	44	14 5
Street Naming	15	18 5	9	13 2	25	11 7
Public Libraries	161	18 4	151	8 0	313	6 4
Town Planning	6	14 7	—	—	6	14 7
Public Depôts and Cottages	166	13 6	154	19 7	321	13 1
Sewers	184	2 11	198	18 9	383	1 8
Refuse Removal and Disposal	2214	3 3	2578	17 9	4793	1 0
Baths and Conveniences	814	12 8	1071	5 9	1885	18 5
Fire Brigade	848	11 5	895	15 2	1744	6 7
Salaries and General Establishment Charges	6934	13 0	6575	19 4	13510	12 4
Town Hall and Corporation Estates	284	2 6	290	17 1	574	19 7
Dividends and Interest	—	—	—	—	—	—
Mayoral Allowances, etc.	43	10 4	153	1 7	196	11 11
Education Rate Contribution	13350	0 0	12700	0 0	26050	0 0
Precepts of Other Authorities:—						
Middlesex County Council	—	—	53976	0 0	53976	0 0
Metropolitan Police	—	—	—	—	—	—
Assessment Committee	—	—	505	0 0	505	0 0
Loan Charges (General)	458	11 0	576	16 2	1035	7 2
Stocks and Stores Accounts	40	0 0	240	0 0	280	0 0
Purchase of Vehicles	—	—	—	—	—	—
Contributions to Housing Account	—	—	—	—	—	—
Purchase of Land and Property	1518	11 7	—	—	1518	11 7
Air Raid Precautions	612	10 8	2395	15 3	3008	5 11
Freedom of the Borough	—	—	—	—	—	—
	£33473	18 10	91130	15 2	124604	14 0
Balance—Surplus					409423	6 6

£534028 0 6

E AND
il, 1939 to

(6)

INCOME ON RATE FUND ACCOUNTS.

31st May, 1939.

Total.
s. d.
37 10 5
19 9 10
27 13 4
40 13 8
78 18 4
26 12 3
44 14 5
25 11 7
13 6 4
6 14 7
21 13 1
83 1 8
93 1 0
85 18 5
44 6 7
10 12 4
74 19 7
— — —
96 11 11
50 0 0
76 0 0
— — —
05 0 0
35 7 2
80 0 0
— — —
18 11 7
08 5 11
— — —
04 14 0
23 6 6
28 0 6

INCOME.	Amount Previously Reported.		Amount now Reported.		Total.	
	£	s. d.	£	s. d.	£	s. d.
Parks, Pleasure Grounds and Open Spaces	485	18 5	443	7 0	929	5 5
General Public Health Services	—	44 3 6	—	2 2 0	—	16 5 6
Hospital and Maternity and Child Welfare	—	35 15 6	—	89 15 10	—	125 11 4
County and Trunk Roads	—	—	2343	0 0	—	2343 0 0
Local Roads	—	—	—	50 0 0	—	50 0 0
Public Lighting	—	—	—	3 11 0	—	4 14 0
Traffic Control	—	—	—	—	—	—
Public Libraries	106	14 10	119	18 9	226	13 7
Town Planning	—	2 10 0	—	5 0 0	—	7 10 0
Public Depôts and Cottages	—	33 19 10	—	41 17 4	—	75 17 2
Sewers and Sewage Disposal	—	12 13 3	—	550 10 0	—	563 3 3
Refuse Removal and Disposal	—	92 2 8	—	120 14 9	—	212 17 5
Baths and Conveniences	—	102 8 5	—	301 1 7	—	403 10 0
Fire Brigade	—	132 9 10	—	179 13 10	—	312 3 8
Salaries and Establishment Charges	—	309 8 6	—	228 4 0	—	537 12 6
Town Hall and Corporation Estates	—	64 11 7	—	104 16 10	—	169 8 5
Dividends and Interest	—	575 5 7	—	22 10 0	—	597 15 7
Loan Charges (General)	—	—	—	—	—	—
Stocks and Stores Accounts	—	159 6 11	—	174 19 3	—	334 6 2
Air Raid Precautions	—	2 11 10	—	3 2 6	—	5 14 4
		2131 3 8		4784 4 8		6915 8 4
General Exchequer Grant—Instalment	14205	0 0	—	—	14205	0 0
	£	s. d.				
Rate Income (First Instalment)	53961	4 18 0				
Less 5% for Allowances, Voids, etc.	26980	14 11				
	51263	4 3 1			51290	7 12 2
Supplementals, etc., to 31st May, 1939	—	—	273	9 1	—	—
	£52897	6 9	5057	13 9	53402	8 0 6
					£53402	8 0 6

(7)

ACCOUNTS EXAMINED AND APPROVED:

The following orders have been made on the Borough Treasurer for payment of accounts examined and approved in pursuance of Standing Orders and Resolutions of the Council:—

List No.	Date Examined.	Examined by.	General A/c.		Loans Pool.	
			£	s. d.	£	s. d.
—	Previously Reported (Per Minutes, page 871)	—	128734	4 8	601	18 11
—	Per Bank Account (Appendix, page 3)	—	£120336	3 7		
<hr/>						
—	Previously Reported (Per Minutes, page 871)	—	33791	6 7	—	—
296—297	19th June, 1939	Councillor L. Hirshfield	—	432 18 6	—	—
28—31	19th June, 1939	Councillor L. Hirshfield	121806	12 4	—	—
32	19th June, 1939	Councillor L. Hirshfield	28633	6 8	—	—
33	19th June, 1939	Councillor L. Hirshfield	—	—	50282	9 5
298	26th June, 1939	Councillor P. Lightfoot	—	673 9 10	—	—
34—37	26th June, 1939	Councillor P. Lightfoot	21066	7 6	—	—
299—300	3rd July, 1939	Councillor A. A. Naar	—	2231 16 7	—	—
38—43	3rd July, 1939	Councillor A. A. Naar	—	9188 16 11	—	—
301—303	10th July, 1939	Councillor T. J. Scott	—	1211 1 0	—	—
44—46	10th July, 1939	Councillor T. J. Scott	—	8633 5 8	—	—
			£227669	1 7 50282	9 5	

REQUISITIONS SUBMITTED TO COMMITTEES.

	1938-39		Amount Previously Reported		Approved during Recess		SUBMITTED TO COMMITTEE		Total to 12th June, 1939		
	£	s. d.	£	s. d.	£	s. d.	Date	Amount	£	s. d.	
SUB-COMMITTEES OF THE EDUCATION COMMITTEE.											
School Management	8178	16 7	—	—	—	—	9th May	1513 18 4	1513	18 4	
Works and General Purposes	3068	17 1	—	—	—	—	6th May	328 19 1	328	19 1	
School Medical Services	647	17 9	85	10 6	—	—	15th May	42 4 6	127	15 0	
Total Education	11895	11 5	85	10 6	—	—		1885	1 11	1970	12 5
COMMITTEES OF THE COUNCIL.											
Public Health and Medical Services:—											
Maternity and Child Welfare	2780	14 5	569	14 1	—	—	15th May	183 8 5	753	2 6	
Public Health	505	18 7	42	3 10	14	10 10	" "	14 14 6	81	8 4	
Isolation Hospital	1145	1 10	80	15 5	—	—	" "	62 4 2	142	19 7	
Highways	30735	0 3	6789	12 10	103	15 6	" "	3602 17 6	10406	5 10	
Estates, Parks and Allotments	3074	8 5	383	11 1	59	16 2	" "	286 15 1	730	2 4	
Works and Fire Brigade:—											
Works	15954	3 7	2060	14 7	94	13 11	22nd May	1169 11 2	3324	19 8	
Fire Brigade	1952	19 10	450	15 11	—	—	" "	452 1 9	902	17 8	
Buildings and Town Planning	2	9 6	—	—	—	—	" "	—	—	—	
Libraries:—											
General	4719	10 3	654	16 1	—	—	" "	485 3 2	1130	19 3	
Books—Central	697	0 0	52	0 0	—	—	" "	55 0 0	107	0 0	
" Golders Green	610	0 0	50	0 0	—	—	" "	53 0 0	103	0 0	
" Mill Hill	531	0 0	43	0 0	—	—	" "	40 0 0	89	0 0	
" School Libraries	257	11 0	—	—	—	—	" "	—	—	—	
Finance and General Purposes:—											
Stationery	3272	0 11	511	6 6	269	0 9	12th June	257 9 0	1037	16 3	
Clerk's Department	171	10 1	—	—	51	17 6	" "	11 5 0	63	2 0	
Rating and Valuation	43	6 5	—	—	—	—	13th June	4 10 0	4	10 0	
Air Raid Precautions	1412	18 8	30	3 0	—	—	16th May	132 13 3	162	16 3	
Total Council	67865	13 9	11728	13 4	591	13 10		6816	13 0	10139	0 2
Total Requisitions	79761	5 2	11814	3 10	591	13 10		8001	14 11	£21180	12 7

EDUCATION SERVICES—School Attendance.

Year ended 31st March	Accommo- dation	NUMBERS ON ROLL		ATTENDANCES	
		At date	Average during year	Average during period	Per- centage
1932 ...	15118	13976	13144	11783	89.6
1933 ...	15298	14131	13971	12340	88.3
1934 ...	14799	14327	14371	12849	89.5
1935 ...	15543	14308	14268	12782	89.6
1936 ...	15943	14258	14340	12820	89.6
1937 ...	15943	14239	14295	12623	88.3
1938 ...	16069	14248	14291	12632	88.3
1939 ...	17269	14322	14181	12753	89.0
Week ended 28th April, 1939	16589	14371	—	13325	92.7
9th June, "	17029	14575	—	13335	91.4

EDUCATION SERVICES—Employment of Children.

DATE		SCHOOL CHILDREN EMPLOYED			EMPLOYMENT CARDS					
					Issued			Returned		
Day	Year	Boys	Girls	Total	Boys	Girls	Total	Boys	Girls	Total
19th April	1932	190	13	203	38	1	39	—	—	8
22nd March	1933	225	14	239	9	—	9	—	—	—
21st March	1934	236	11	247	19	—	19	—	—	—
21st March	1935	360	12	372	23	1	24	3	2	—
20th March	1936	339	17	356	20	—	20	6	—	5
7th April	1937	244	15	259	30	4	34	24	2	6
24th March	1938	353	17	370	38	2	40	8	—	26
22nd March	1939	332	10	342	21	—	21	8	1	9
Period 1939/40										
3rd May	1939	276	10	286	28	1	29	33	1	34
14th June	"	298	10	308	30	—	30	16	—	16

HEALTH SERVICES—School Medical Statistics.

Year ended 31st December	MEDICAL				DENTAL				
	Examinations			Infectious Cases		Attendances at Clinics		Children Examined	Requiring Treatment
	Routine	Special	No. of Def- ects found	Notifi- able	Other	Medical	Dental		
1932 ...	5307	8179	3062	165	1680	37232	5896	11795	7020
1933 ...	4921	8969	2871	318	706	36093	6140	9436	4470
1934 ...	3796	7453	2477	496	1172	33001	7507	11898	6739
1935 ...	4709	6846	2531	201	1039	32156	8588	13407	7538
1936 ...	5497	7101	2859	142	1712	38215	13081	9154	6198
1937 ...	4419	7087	1719	155	1054	35570	13782	9569	6055
1938 ...	4457	7717	1679	220	1095	41163	13204	6585	3995
1939									
4 weeks to 28th Jan.	304	490	122	16	40	2477	1190	732	322
4 weeks to 28th Feb.	535	691	211	37	29	3418	1224	603	385
6 weeks to 8th April	731	1113	253	34	56	5088	1517	979	517
4 weeks to 6th May	324	739	121	22	67	2838	937	323	191
6 weeks to 17th June	590	998	160	37	55	4777	1523	1198	705

HEALTH SERVICES—Maternity & Child Welfare Statistics.

Table I. Attendances for 6 weeks to 17th June, 1939.

Nature of Service	HEALTH CENTRES									
	Central Hendon	West Hendon	Child's Hill	Watling Estate	Mill Hill	Temple Fortune	Edgware	Colindale	Woodside Park	Total
Maternity—General										
Ante-Natal	66	112	116	86	151	—	—	—	—	531
Children under 5 ...	849	748	1012	1430	1071	385	735	483	240	6953
Dental										
Ante-Natal	58	—	46	26	32	—	—	—	—	162
Children under 5 ...	22	—	14	40	24	—	—	—	—	100
Eye										
Children under 5 ...	34	—	—	14	—	—	—	—	—	48
Orthopaedic										
Children under 5 ...	128	—	—	57	—	—	—	—	—	185
Ophthalmia Neonatorum										
Regulations 1926	—	—	—	—	—	—	—	—	—	—
No. of cases to	—	—	—	—	—	—	—	—	—	—
St. Margaret's Hospital	—	—	—	—	—	—	—	—	—	—
Queen Charlotte's "	—	—	—	—	—	—	—	—	—	—
City of London "	—	—	—	—	—	—	—	—	—	—

Table II. General.

Year ended 31st December	MATERNITY CENTRES								Midwives Services		Grants Assisted Milk Supply
	Number of Centres	SESSIONS					Home Visita- tions	Cases attended	Visits		
		Number	Child Atten- dances	Ante Natal Attendances	Total	Average per Session				New Mem- bers	
1932	6	632	33587	597	35184	57	1444	17087	103	2167	156
1933	7	699	33325	687	39512	57	1552	17933	91	2021	268
1934	7	713	39182	1079	40267	57	1618	16008	113	2401	1220
1935	7	712	41249	1242	42491	59	1784	14150	110	2294	1588
1936	8	767	44521	1692	46029	60	1799	15527	118	2440	1715
1937	8	811	49544	2391	51935	64	1823	14571	110	2555	2091
1938	8/9	942	59535	4288	63823	68	2091	15058	134	3320	3032
1939											
4 weeks to 28th Jan.	9	80	4481	376	4857	61	157	1116	28	585	293
4 weeks to 28th Feb.	9	80	5273	402	5675	71	191	892	15	418	292
6 weeks to 8th April	9	116	7211	645	7856	68	238	1670	29	660	417
4 weeks to 6th May	9	72	4700	487	5187	72	154	1118	16	406	257
6 weeks to 17th June	9	116	7286	693	7979	69	225	1385	23	504	350

HENDON BOROUGH (Nursing Associations) SCHEME, 1935.

Number of cases and visits made on behalf of the Hendon Borough Council (children under 5, and expectant and nursing mothers). Scheme operative from 1st October, 1935.

Disease	Year to 31st Dec., 1937		Year to 31st December, 1938		Statistics for Period from 1st January to 31st March, 1939											
	Cases	Visits	Cases	Visits	Edgware and Little Stanmore		Watling		West Hendon and Colindale		Golders Grn. and East Cricklewood		Mill Hill		Totals	
					Cases	Visits	Cases	Visits	Cases	Visits	Cases	Visits	Cases	Visits	Cases	Visits
Infantile Diseases—																
Notifiable	2	58	5	34	—	—	—	—	—	—	—	—	—	—	—	—
Other	465	2198	518	2249	12	45	59	204	20	204	9	53	3	8	103	514
Maternal Diseases—																
Notifiable	—	—	3	30	—	—	—	—	—	—	—	—	—	—	—	—
Other	30	196	24	153	2	23	—	—	—	—	3	18	1	5	6	46
Diseases—																
Notifiable	—	—	—	—	—	—	—	—	—	—	—	—	—	—	—	—
Other	167	1123	22	176	1	7	13	85	1	4	—	—	4	55	19	111
Poor Law Cases ..	1	10	—	—	—	—	—	—	—	—	—	—	—	—	—	—
Totals	665	3565	572	2642	15	75	72	289	21	208	12	71	8	68	128	711

HEALTH SERVICES—General Health Statistics. Table I.

6 weeks to 17th June, 1939.

REMISSION OF FEES		DISEASES NOTIFIED		SANITATION	
Service	Number of Cases	Name	Number of Cases	Details	Number
Doctor under Midwives Acts	8	Scarlet Fever	42	Inspections, visits and Re-inspections made	1378
Council Midwife	3	Diphtheria	14	Complaints received and investigated ...	187
Provision of Dentures	7	Pulmonary Tuberculosis	17	Preliminary and Statutory notices served... ..	90
Dental Treatment	1	Other Forms Tuberculosis	—	Notices Complied with	83
Maintenance in Hospital for confinement	—	Puerperal Fever	—	Special Drain Tests ...	3
Maintenance in Orthopaedic Hospital	2	Puerperal Pyrexia	13		
Provision of Orthopaedic Appliance	2	Erysipelas	3		
Provision of Spectacles... ..	2	Pneumonia	13		
Tonsillectomy	6	Dysentery	—		
Maintenance in Convalescent Home	2	Food Poisoning	—		
Maintenance at Russell Cotes School	6	Ophthalmia Neonatorum	—		
X-Ray Treatment	1	Typhoid Fever... ..	—		
Accouchement Sets	5	Poliomyelitis	—		
Treatment of Squint	1	Malaria	—		
		Cerebro Spinal Fever... ..	—		
		Meningitis	—		
Total	46	Total	102		

General Health Statistics. Table II.

Year ended 31st December	POPULATION				Population 30th June	INFECTIOUS DISEASES				
	Births		Deaths			Notifications		Cases removed to Hospital		Cases under Treatment in Hospital at Date
	Adjusted Total	Per 1000	Adjusted Total	Per 1000		Number	Per centage	Hendon	Other	
1932	1688	13.70	1036	8.40	124477	761	6.15	311	133	47
1933	1673	13.41	1013	7.93	129698	1024	7.86	513	125	97
1934	1643	12.53	1065	8.12	138643	1322	9.53	782	117	102
1935	1724	12.85	1146	8.54	146720	806	6.11	515	96	50
1936	1835	13.04	1166	8.29	155800	777	5.0	301	99	53
1937	1674	10.32	1558	9.61	162070	828	5.11	342	87	64
1938	1914	11.63	1500	9.12	165343	1000	6.05	484	87	55
1939										
4 weeks to 28th Jan.	156	—	182	—	—	75	—	36	1	44
4 weeks to 28th Feb.	164	—	154	—	—	76	—	59	3	76
6 weeks to 8th April	240	—	237	—	—	144	—	67	4	69
4 weeks to 6th May	167	—	145	—	—	95	—	66	3	60
6 weeks to 17th June	290	—	163	—	—	102	—	67	2	51

FIRE BRIGADE SERVICES.

	FIRE BRIGADE.					AMBULANCE.				
	1935-36	1936-37	1937-38	1938-39	1st Apr. to 31st May, 1939	1935-36	1936-37	1937-38	1938-39	1st Apr. to 31st May, 1939
CALLS—						CALLS—				
Hendon Area ..	184	171	216	265	35	Private Calls ..	781	945	1020	1304
Kingsbury Area ..	11	—	—	5	—	Street Calls ..	669	683	721	737
Other Areas ..	1	—	2	6	—	Total ..	1450	1628	1741	2041
False Alarms ..	61	36	47	57	6	Mileage run ..	13024	15467	15750	17361
Total ..	257	207	265	333	41	SPECIAL CALLS (Included in Total)				
Mileage run ..	1296	808	1055	1959	310	For Finchley ..	34	27	23	22
TELEGRAMS—						For other Authorities	13	1	5	—
Alarms ..	4730	4502	5050	5604	1107	Finchley for Hendon	—	4	1	4
Hydrants ..	1627	1978	2003	2293	246	Other Authorities for Hendon ..	—	1	5	2
INSPECTIONS—										
Petrol, Factory, etc.	826	702	747	554	2					
Private Appliances	233	179	197	49	—					

REFUSE DESTRUCTOR.

	1935-36		1936-37		1937-38		1938-39		1st April to 31st June, 1939	
	T.	C.	T.	C.	T.	C.	T.	C.	T.	C.
OUTGOING MATERIALS—										
Fine Crushed Clinker	—	—	—	—	—	—	414	4	209	5
Coarse ditto	—	—	—	—	—	—	716	10	499	10
Fine Stuff sold	4863	5	5541	12	4806	9	2745	17	—	—
Fine Stuff used by Departments ..	5040	10	3393	—	5428	10	5867	1	1376	10
Clinker Sold	1852	16	526	18	54	9	2270	19	806	9
Clinker used by Departments ..	218	7	729	16	68	7	912	19	81	19
Clinker supplied for Contract Works ..	2143	15	161	3	5406	13	2079	10	125	8
Tins (Bright) Sold	530	4	525	10	576	14	632	34	184	12
Tins (Galvanised) Sold	142	14	146	7	161	2	136	11	5	14
Bottles and Cullett Sold	401	15	473	10	914	1	499	1	98	11
Paper Sold	—	10	—	—	—	—	29	7	35	5
INCOMING REFUSE—										
House Refuse weighed in	30842	6	33678	3	34278	11	33408	6	6944	9
Trade Refuse	374	4	447	16	589	19	668	15	184	19
School Refuse	—	—	153	5	139	9	159	5	30	11
ELECTRICITY GENERATED—										
Workshop (Central Depot)	—	—	—	—	5438	—	4247	—	766	—
Refuse Destructor Works	—	—	28658	—	170380	—	193943	—	36971	—
Clinker Crushing Plant	—	—	—	—	—	—	3807	—	1235	—
Totals	—	—	28658	—	175818	—	201997	—	38972	—

ADVANCES UNDER THE SMALL DWELLINGS ACQUISITION ACTS
from 3rd July, 1925, to 31st May, 1939.

	Advances completed		Council's Valuation		Amount Applied for		Amount Advanced		Advances now Outstanding		
	Number	Purchase Price	Amount	Per-centage	Amount	Per-centage	Amount	Per-centage	Amount	Per-centage	Number
Now Reported											
Details	307	279004	255224		205688		199633		45790		143
Percentages of Purchase Price				91%		80%		71%		18%	
Valuation								78%		23%	
Amt. Applied for Advances								97%			
Previous Return											
Details	307	279004	255224		205688		199633		40440		145
Percentages of Purchase Price				91%		80%		71%		15%	
Valuation								78%		23%	
Amt. Applied for Advances								97%			

HOUSING STATISTICS.

Year Ended 31st March	No. of Houses	COLLECTIBLE			TOTAL	COLLECTED			REPAIR NOTES		Electricity Charges Collected	No. Empty at End
		Gross Rents	Nett Arrears Brought Forward			Rents Received	Void, Written Off, etc.	Nett Arrears Carried Forward	Issued during Month	Jobs Done		
1936	1150	46881 7 10	380 19 1	47262 6 11	46322 17 3	491 11 10	447 17 10	—	—	861 13 11	7	
1937	1150	45962 11 9	447 17 10	46410 9 7	45617 2 1	223 12 4	569 15 2	—	—	1133 3 1	2	
1938	1169	46046 6 1	569 15 2	46616 1 3	45945 15 1	119 15 2	550 11 0	—	—	1478 18 7	1	
1939												
Week ended												
April 3	1290	1047 5 2	540 19 2	1588 4 4	1080 14 9	3 14 3	503 15 4	—	—	42 6 6	4	
10	1290	1047 5 2	503 15 4	1551 0 6	1013 17 4	3 11 2	533 12 0	—	—	43 15 9	4	
17	1290	1047 5 2	533 12 0	1580 17 2	1023 4 8	6 8 1	551 4 5	—	—	43 9 1	7	
24	1290	1047 7 9	551 4 5	1598 12 2	1071 1 11	4 8 1	523 2 2	175	230	45 4 6	5	
May 1	1290	1047 7 9	523 2 2	1570 9 11	1052 9 3	4 12 11	513 7 9	—	—	44 3 11	5	
8	1290	1047 7 9	513 7 9	1560 15 6	1041 14 10	5 10 8	513 10 0	—	—	44 2 2	6	
15	1290	1047 7 9	513 10 0	1560 17 9	1033 18 8	4 1 7	522 17 6	—	—	44 7 9	4	
22	1290	1047 7 9	522 17 6	1570 5 3	1022 14 3	3 18 3	543 12 9	—	—	42 14 8	4	
29	1290	1047 7 9	543 12 9	1591 0 6	1011 9 8	3 10 0	576 0 10	98	258	42 2 4	4	
		£ 9426 2 0	540 19 2	9967 1 2	9351 5 4	39 15 0	576 0 10	273	488	392 6 8	4	

1938-39	1304 737	238 165
	2041	403
	17361	4710
	22	3
	4	1
	2	1

1st April to 13th June, 1939	T. C.
	209 5
	499 10
	1376 10
	820 0
	81 10
	225 8
	184 12
	5 14
	98 11
	35 5

6:44 9
134 19
30 11
B.T. Units
760
3671
1235
58972

ACTS

Advances Outstanding	Per-centage	Number
		145
	18%	
	25%	
		145
	18%	
	25%	

LIBRARY SERVICES.—Statistics for May, 1939.

Table I. Members.

Distribution of Resident Members				Distribution of Non-Resident Members		
Ward	Population, June 1938 (est.)	Total Members	Percentage of Population	Library Authority	Employees, Scholars and those qualified under reciprocal agreements	Subscribers
Central	19416	6516	33.56	Finchley	382	—
Park	16671	5304	31.82	Middlesex	603	—
Golders Green	15695	5524	35.19	Adjoining Library Authorities—		
Mill Hill	24899	3740	35.1	(a) Hampstead	32	—
Childs Hill	18396	3858	20.97	(b) Willesden	33	—
Burnt Oak	21200	5899	27.84	Metropolitan Boroughs	74	1
West Hendon	19232	3971	15.96	(excluding Hampstead)		
Garden Suburb	15347	6081	39.62	Other Authorities	95	4
Edgware	14487	2844	19.63			
Total	165343	47837	28.93	Total	1219	5

Table II. General - Year 1939/40.

Type	Lectures						Inter Library Loans		Donations	
	Central		Golders Green		Mill Hill		Volumes		Details	Number
	Number	Attendance	Number	Attendance	Number	Attendance	Borrowed	Lent		
Now Reported							44	25		
University Extension	—	—	—	—	—	—			Volumes ...	370
Public Lectures	—	—	—	—	—	—			Pamphlets ...	25
Talks to Children	—	—	—	—	—	—			Maps ...	—
Story Half-Hours	—	—	—	—	—	—			Sets of Cigarette Cards	—
Total	—	—	—	—	—	—	44	25	Total ...	595
Previously Reported							34	28		
University Extension	1	10	—	—	—	—			Volumes ...	33
Public Lectures	—	—	—	—	—	—			Pamphlets ...	30
Talks to Children	—	—	—	—	—	—			Maps ...	11
Story Half-Hours	—	—	—	—	—	—			Sets of Cigarette Cards	3
Total	1	10	—	—	—	—	34	28	Total ...	77

LIBRARY SERVICES.

Comparative Table of Issues.

Period	Central Library		Golders Green Branch		Mill Hill Branch		Deposit Stations	School Libraries	Total (All Services)
	Total Issues.	Daily Average	Total Issues	Daily Average	Total Issues	Daily Average			
March 1933 ...	43948	1920					380	13012	57340
March 1934 ...	42613	1639							
March 1935 ...	41153	1584					477	18701	61791
March 1936 ...	39930	1501	35669	1372			373	21084	62610
March 1937 ...	40323	1613	35946	1401			297	15717	90703
March 1938 ...	37901	1409	34958	1261	32207	1193	277	15693	91334
March 1939 ...	39416	1461	33581	1243	39426	1127	—	23095	127321
								36884	134337
Period 1939-40									
April 1939 ...	37401	1626	33090	1439	29509	1283	—	7504	107504
May	38491	1480	32379	1245	27729	1065	—	15947	114546

Classified Table of Issues—May, 1939.

Classification	Central Library	Golders Green Branch	Mill Hill Branch	Total Central and Branches	School Libraries	Total (All Services)
General Works ...	1067	267	421	1755	278	2033
Philosophy ...	372	214	185	771	30	801
Religion ...	341	245	191	777	145	922
Sociology ...	1833	1078	940	3851	770	4621
Languages ...	541	167	224	932	24	956
Science ...	1011	599	821	2431	688	3119
Useful Arts ...	2002	699	1442	4233	1002	5235
Fine and Recreative Arts ...	1188	695	712	2595	398	2993
Music ...	767	345	326	1478	—	1478
Literature ...	2398	2321	1208	5927	512	6439
History and Topography ...	3402	2144	2061	7607	576	8183
Biography ...	1735	1670	1036	4441	213	4654
Local ...	298	—	—	298	—	298
Fiction ...	17003	18890	14868	50761	—	50761
Story Books ...	2555	2948	3294	8797	11311	20108
Books for the Blind... ..	26	—	—	26	—	26
Illustrations ...	182	—	—	182	—	182
Holiday Literature ...	1680	57	—	1737	—	1737
TOTAL ...	38491	32379	27729	98599	15947	114546
Daily average issue... ..	1480	1245	1065	—	—	—
Days open	26	26	26	—	—	—

COMPARATIVE STATISTICS.

PUBLIC PARKS.

YEAR ENDED 31st March	TENNIS						BOWLS		PUTTING	MINI-TURE GOLF Tickets Sold	CONVENIENCE FEES (Nos.)
	Courts	Single Tickets	Double Tickets	Court Tickets	Book Tickets	Special Tickets	Rinks	Tickets Sold	Tickets Sold		
1933	30	3333	1701	3944	81	159	12	194	16840	—	3831
1934	30	1787	471	9435	233	115	12	326	17010	—	5674
1935	32	2633	698	8483	211	177	12	129	16191	5587	7976
1936	32	2511	631	8188	193	119	12	183	13919	4928	7494
1937	32	3154	930	9250	196	208	12	1108	13589	5360	7697
1938	32	4201	1112	11898	225	197	12	500	12058	5659	11269
1939	34	4186	1050	13245	242	155	12	343	16192	6545	12765

1st April, 1939, to 31st May, 1939.

Basing Hill ..	2	74	22	224	2	—	—	—	235	—	444
Childs Hill ..	2	52	11	136	8	—	6	6	—	—	—
Clitterhouse ..	4	37	44	133	1	—	—	—	—	—	233
Hendon ..	9	279	79	1000	30	13	—	—	1134	—	130
Mill Hill ..	3	115	52	326	10	24	6	88	—	1009	292
Princes ..	2	110	31	203	7	—	—	—	—	—	92
Stone Grove ..	2	111	11	299	3	—	—	—	249	—	463
Sunny Hill ..	4	59	14	263	4	10	—	—	289	—	251
Watling ..	2	26	—	217	4	—	6	224	634	—	—
West Hendon ..	2	22	4	131	1	—	—	—	—	—	240
Montrose ..	2	10	5	92	2	—	—	—	—	—	267
Totals ..	34	895	273	3084	72	47	18	318	2541	1009	2415
Increase on last return	—	350	122	1978	48	36	6	316	2541	1001	1497

PUBLIC LAVATORIES.

YEAR ENDED 31st March	LADIES						GENTLEMEN					
	Convenience			Nos.	Towels		Convenience		Towels		Nos.	
	W.C's	Free	Total		Basins	Nos.	W.C's	Nos.	Basins	Nos.		
1933	12	3	15	29812	4	171	11	33793	4	603		
1934	10	4	23	37616	6	177	16	40270	6	786		
1935	28	4	32	42268	10	304	21	53589	10	1192		
1936	28	4	32	51133	10	551	21	68272	10	1870		
1937	28	4	32	56804	10	1839	21	77244	10	2397		
1938	28	4	32	64154	10	1919	21	78912	10	2762		
1939	33	5	38	62706	12	1971	25	81947	12	2744		

1st April, 1939, to 31st May, 1939.

"The Bell" ..	5	1	6	1562	2	54	4	2091	2	95
Childs Hill ..	4	1	5	2429	2	63	4	2127	2	96
Cricklewood Lane ..	2	—	2	481	—	—	2	2597	—	—
Edwards ..	5	—	5	1570	2	69	2	1358	2	66
Mill Hill ..	4	—	4	2705	2	85	3	1465	2	118
Orange Hill Road ..	5	1	6	1139	2	61	3	1436	2	103
West Hendon ..	3	1	4	1365	—	20	3	1798	—	—
Hendon Central ..	5	1	6	1752	2	71	4	1481	2	109
Totals ..	33	5	38	13003	12	423	25	14353	12	617
Increase on last return	—	—	—	7540	—	219	—	7976	—	310

PUBLIC SLIPPER BATHS.

YEAR ENDED 31st March	1st CLASS		2nd CLASS		Extra Towels	Soap	Unemployed (Free Baths)
	No. of Baths	Tickets Sold	No. of Baths	Tickets Sold			
1933	8	3967	25	17980	962	6925	331
1934	8	3752	25	19113	844	7242	141
1935	8	3856	25	19251	875	7499	46
1936	8	3571	25	18230	821	7310	19
1937	8	3581	25	19385	1141	8074	61
1938	8	3536	25	21040	1206	8281	100
1939	8	2730	25	20500	1185	7516	69

1st April, 1939, to 26th May, 1939.

Child's Hill.							
Ladies ..	2	15	5	519	1	23	—
Gentlemen ..	2	155	6	667	40	273	—
Total ..	4	170	11	1186	50	296	—
West Hendon.							
Ladies ..	2	25	6	616	45	284	—
Gentlemen ..	2	327	8	1385	80	582	7
Total ..	4	352	14	2001	125	866	7
Total of both	8	522	25	3207	175	1162	7
Increase on last return	—	281	—	1739	94	626	3

OPEN AIR SWIMMING POOL—MILL HILL.

(16)

Details.	1937		1938		1939	
	1st May—3rd October	Tickets Sold	30th April—27th Sept.	Tickets Sold	24th April to 23rd June.	Tickets Sold
SESSIONS:—						
Adults.—						
Sundays & Bank Holidays	10476		6556		2266	
Weekdays	35242	40718	21368	27924	7009	9275
Children.—						
Sundays & Bank Holidays	4987		3441		1166	
Weekdays	23589	28576	18955	22396	5742	6908
Season Pass.—						
Sundays & Bank Holidays	1874		1594		686	
Weekdays	6814	8688	6604	8195	3670	3756
SUB-TOTAL		77982		58518		19939
School Children.—						
Hendon	9661		6395		2263	
Other Authorities	—	9661	878	7268	1432	3095
TOTAL BATHERS		87043		65786		23634
MISCELLANEOUS:—						
Parking.—						
Cars	3438		2347		919	
Motor Cycles	503		381		127	
Bicycles	9487		7260		2768	
Season Tickets	1		2		—	
Deposits.—		13489		9990		5814
Costumes		4010		1835		592
Season Tickets.—						
Resident	202					
Adults			62		68	
School Children			160		245	
Non-Resident	5		2		2	
Hire of Towels, Cap, Costume and Slips		257		254		345
Weighing Machines		9856		5829		1996
		3557		2587		823

OPEN AIR SWIMMING POOL—WEST HENDON.

Details.	1937		1938		1939	
	3rd July—3rd October	Tickets Sold	30th April—2nd Oct.	Tickets Sold	24th April to 23rd June, 1939	Tickets Sold
SESSIONS:—						
Adults.—						
Sundays & Bank Holidays	2568		—		—	
7 a.m. to 12.30 p.m.....	—		2171		685	
1.30 p.m. to closing.....	—		1852		741	
Weekdays	9549	12117	11956	15929	3708	5134
Children.—						
Sundays & Bank Holidays	1124		—		—	
7 a.m. to 12.30 p.m.....	—		674		266	
1.30 p.m. to closing.....	—		1039		466	
Weekdays	6363	7487	8547	10260	2412	3024
Season Pass.—						
Sundays & Bank Holidays	506		836		431	
Weekdays	1932	2438	2853	3689	1469	1900
SUB-TOTAL		22041		29878		10038
School Children.—						
Hendon	981		6825		4856	
Other Authorities	—	981	—	6825	—	4856
TOTAL BATHERS		23021		26703		14914
MISCELLANEOUS:—						
Parking.—						
Cars	176		304		—	
Motor Cycles	82		119		—	
Bicycles	937		2237		—	
Season Tickets	—		—		—	
Deposits.—		1195		2660		366
Costumes		1148		1036		—
Season Tickets.—						
Resident	43		—		—	
Adults			35		23	
School Children			23		56	
Non-Resident	9		5		1	
Hire of Towels, Cap, Costume and Slips		52		63		80
Weighing Machines		3206		3662		1343
		—		900		205

MILL HILL GOLF TICKETS SOLD

5387	381
4928	5671
5300	7976
5659	7494
6545	7597
	11254
	12753

CONVEYANCE FEES (1918)

445

231

130

1029

202

92

451

251

210

257

1000

2415

1001

1427

MEN

Towels

Basins	Nos.
4	662
6	786
10	1192
10	1870
10	2397
10	2761
12	2744

Unemploy- ed (Free Baths)

331

144

46

19

61

100

69

7

7

7

3

WAGES RETURN.

Year Ended 31st Mar.	Net Wages Paid.	Deductions						* Contributions N.H. & U. Insurances	TOTAL
		Compulsory		Voluntary					
		Super-annuation	N.H. & U. Insurances	Sports Club Subscriptions Socials		Industrial Orthopaedic Society	Rents, Rates, etc.		
1932	81898 7 0	1416 7 3	1557 11 9	—	—	—	—	1688 5 1	87976 18 4
1933	82166 4 3	1368 7 2	1711 2 11	—	—	—	—	1805 7 10	88419 9 4
1934	95367 11 9	2049 0 2	1971 13 10	—	—	—	—	2077 11 2	103514 17 1
1935	102007 4 7	2107 11 7	2101 18 11	—	—	50 8 0	—	2215 12 6	110591 7 2
1936 (53 weeks)	107592 19 3	2581 11 11	2227 13 2	—	—	58 19 11	—	2360 4 4	117403 0 6
1937	106580 12 3	2465 6 2	2072 2 11	—	—	56 17 4	—	2210 3 5	115850 8 3
1938	116027 19 0	2405 4 10	2204 5 1	—	—	57 0 2	—	2383 10 5	125483 4 4
1939	£128550 1 2	2456 0 3	2335 19 2	134 8 0	561 2 6	56 10 2	—	2529 14 3	13979 15 9

* NOTE.—The contribution in respect of superannuation is equivalent to the deduction.

1939 Week Ended	Net Wages Paid.	Super-annuation	N.H. & U. Insurances	Subscriptions	Socials	Industrial Orthopaedic Society	Rents, Rates, etc.	* Contributions N.H. & U. Insurances	TOTAL
April 4	2399 9 4	49 5 10	43 4 1	3 2 8	15 3 4	1 2 2	—	46 17 10	2607 11 1
11	2459 5 3	49 17 0	44 8 4	3 5 4	15 10 2	1 2 3	—	48 5 11	2671 11 3
18	2492 13 10	49 16 9	45 10 10	3 3 6	15 12 6	1 2 4	30 3 3	48 14 4	2736 14 1
25	2513 9 0	49 17 2	40 12 4	3 4 8	15 9 4	1 2 4	44 6 7	50 8 4	2774 6 11
May 2	2566 8 5	49 9 4	47 3 0	3 7 4	15 6 8	1 2 1	45 4 9	51 6 3	2828 17 2
9	2585 6 4	49 4 2	46 16 11	3 5 10	15 13 8	1 2 2	44 16 7	50 16 10	2846 6 8
16	2620 0 10	49 5 11	48 2 11	3 4 10	15 12 8	1 2 2	46 11 8	52 3 10	2885 19 9
23	2637 18 9	49 9 10	49 0 6	3 5 0	16 0 0	1 2 3	47 7 4	53 0 5	2906 13 11
30	2676 4 4	49 9 5	48 15 0	3 10 10	16 9 2	1 2 3	48 10 6	53 1 5	2946 12 4
June 6	2762 6 5	40 13 11	50 13 3	3 11 0	16 19 6	1 2 2	48 9 7	54 10 10	3037 0 7
13	2738 5 1	49 5 8	50 16 1	3 9 4	17 9 8	1 2 4	48 3 5	54 14 11	3012 12 2
20	2748 13 6	49 6 9	51 9 7	3 12 4	17 12 8	1 2 3	47 2 6	55 16 4	3024 2 8
Totals	£31200 10 1	*594 1 9	572 12 10	40 2 8	192 19 4	13 6 9	450 16 2	619 17 3	34278 8 7

* The contribution has the effect of doubling this sum.

LOAN DEBT STATEMENT

Particulars.		Balance Outstanding 1st April.	New Loans	Repayments	Balance Outstanding 31st March.
Year to 31st March, 1932	...	£2,012,708 3 8	£205,025 10 9	£85,745 3 8	£2,131,988 10 9
Year to 31st March, 1933	...	£2,131,988 10 9	£150,932 19 6	£135,395 12 10	£2,147,525 17 5
Year to 31st March, 1934	...	£2,147,525 17 5	£805,020 17 2	£615,939 18 2	£2,336,606 16 5
Year to 31st March, 1935	...	£2,336,606 16 5	£70,120 0 0	£67,764 2 9	£2,338,962 13 8
Year to 31st March, 1936	...	£2,338,962 13 8	£75,500 0 0	£182,049 18 2	£2,232,412 15 6
Year to 31st March, 1937	...	£2,232,412 15 6	£241,250 0 0	£66,785 18 9	£2,406,876 16 9
Year to 31st March, 1938	...	£2,406,876 16 9	£247,052 12 8	£310,238 4 0	£2,343,691 5 5
Year to 31st March, 1939	...	£2,343,691 5 5	£506,957 1 10	£447,062 6 11	£2,403,586 0 4
Purpose.		Balance Outstanding 1st April, 1939	New Loans and Advances to Borrowing Accounts to 31st May, 1939	Repayments and Advances from Loans Pool to 31st May, 1939	Balance Outstanding at 31st May, 1939
Sewerage and Sewage Disposal	...	28043 12 2	—	213 14 7	28017 17 7
Road Improvements:—					
Main and County Roads	...	84647 2 0	—	—	84647 2 0
Local Roads	...	84210 7 2	—	—	84210 7 2
Private Streets	...	53133 4 10	—	—	53133 4 10
Public Lighting	...	2500 0 0	—	—	2500 0 0
Parks and Pleasure Grounds	...	449888 1 6	—	20 6 8	449867 14 10
Public Offices and Buildings	...	63367 14 6	—	38 19 4	63328 15 2
Public Depots	...	16617 10 0	—	—	16617 10 0
Fire Station, etc.	...	22959 17 8	—	—	22959 17 8
Health Services:—					
House Refuse Collection	...	23733 2 8	—	—	23753 2 8
Hospitals	...	57258 11 6	—	—	57258 11 6
Maternity and Child Welfare	...	17018 19 1	—	—	17018 19 1
Public Conveniences	...	8357 7 1	—	—	8357 7 1
Mortuary	...	145 0 9	—	19 12 1	125 8 8
Baths and Washhouses	...	40917 7 4	—	—	40917 7 4
Public Libraries	...	40230 6 5	—	—	40230 6 5
Allotments	...	1245408 4 8	—	302 12 8	1245105 12 0
Small Dwellings Acts, Advances	...	13502 4 10	—	—	13502 4 10
Housing (1923 Act), Subsidies	...	47151 13 0	—	—	47151 13 0
Housing	...	140 2 8	—	—	140 2 8
Housing	...	675790 0 4	—	—	675790 0 4
Education:—					
Elementary	...	343539 11 10	—	122 3 3	343417 8 7
Higher	...	7689 1 0	—	66 15 4	7622 5 8
Loans Pool	...	2333220 18 4	10000 0 0	491 11 3	2332729 7 1
	...	70365 2 0	—	100 0 0	80205 2 0
Total	...	£2,403,586 0 4	£10,000 0 0	£501 11 3	£2,412,994 9 1

(19)

LOAN SANCTIONS RECEIVED—From 1st April, 1939, to 26th June, 1939:

No.	Date of Sanction.	Purpose.	Amount.	Period. Years.
506	3rd May, 1939	Cricklewood Lane Improvement	£ 6578	20
508	13th June, 1939	Edgwarebury Lane Improvement	5920	15
509	19th June, 1939	Broadfields Avenue School—Building	25824	40
510	19th June, 1939	Broadfields Avenue School—Heating	1184	15

PAYMENTS TO CONTRACTORS UNDER ENGINEER'S CERTIFICATES:

From 1st April, 1939, to 26th June, 1939.

Contract Works No.	Amount of Contract.	Amounts Certified by Engineer.				Total Certified.	Amount of Retention.
		Previously Reported.	Now Reported.		Total Certified.		
			Certificate Numbers.	Amount.			
	£ s. d.	£ s. d.		£ s. d.	£ s. d.	£ s. d.	
301	31446 15 2	20360 0 0	9	5766 8 10	26126 8 10	— — —	
340	9755 0 0	9164 7 2	—	— — —	9164 7 2	— — —	
355	18288 0 0	15325 0 0	9	1000 0 0	16325 0 0	914 0 0	
365	7573 5 0	6549 0 0	9	708 6 5	7257 6 5	— — —	
368	1600 0 0	1182 0 0	3	62 7 6	1244 7 6	— — —	
369	2675 0 0	2033 0 0	6	150 12 1	2183 12 1	— — —	
371	20473 0 0	17253 0 0	—	— — —	17253 0 0	2047 0 0	
371	1448 0 0	1297 6 6	—	— — —	1297 6 6	144 3 0	
378b	9611 13 7	5200 0 0	6 & 7	2192 0 0	7392 0 0	821 19 4	
381	4194 7 2	1864 15 9	—	— — —	1864 15 9	— — —	
386	853 0 0	713 6 0	—	— — —	713 6 0	79 5 0	
386	5163 0 0	3995 0 0	—	— — —	3995 0 0	999 0 0	
389	1375 6 7	923 2 3	—	— — —	923 2 3	— — —	
394	552 12 10	419 4 1	—	— — —	419 4 1	— — —	
397	23577 18 3	18242 0 0	—	— — —	18242 0 0	2358 0 0	
398	790 0 0	790 0 0	—	— — —	790 0 0	— — —	
399	34179 4 6	16800 0 0	5	4135 0 0	20935 0 0	5233 0 0	
400	590 0 0	— — —	1	192 0 0	192 0 0	48 0 0	
401	1369 9 9	534 0 0	—	— — —	534 0 0	59 4 1	
401	1415 17 10	582 0 0	—	— — —	582 0 0	64 5 1	
401	3006 7 3	1350 0 0	—	— — —	1350 0 0	149 1 0	
401	867 0 2	333 0 0	—	— — —	333 0 0	36 16 9	
401	Kerb	1008 0 0	2	100 2 0	1108 2 0	— — —	
401	Surfacing	1887 6 2	—	— — —	1887 6 2	— — —	
401	Surfacing	218 3 1	—	— — —	218 3 1	— — —	
405	414 0 0	328 6 10	3	36 0 0	364 6 10	— — —	
A.R.P. Trenches	— — —	2934 11 8	—	— — —	2934 11 8	— — —	
A.R.P. Shelters	— — —	649 8 9	—	476 8 6	825 17 3	— — —	
A.R.P. Timber	— — —	5407 3 4	—	— — —	5407 3 4	— — —	
Brent Street Paving	1200 0 0	923 1 0	—	— — —	923 1 0	— — —	

1939:

Amount.	Period.
£	Year.
0578	
5920	20
5824	15
1184	30
	15

CATES:

Amount of Retention.

s. d.

£ s. d.

8 10

7 2

0 0 914 0 0

5 5

6

1

0 2047 0 0

6 144 3 0

0 821 19 4

0

0 79 5 0

0 999 0 0

3

1

0 2358 0 0

0

0 5233 0 0

0 48 0 0

0 59 4 1

0 64 5 1

0 140 1 0

0 36 16 9

0

0

2

1

0

3

3

QUOTATIONS ACCEPTED, CONTRACTS LET, ETC.:

(20)

Date of Minute.	Minute Folio.	Particulars.	Amount of Contract.
1939.			
Estates, Parks and Allotments:—			
			£ s. d.
5th May	609	Lease for Grazing—Arrandeno	2 0 0
5th May	610	Sale of Refreshments—Permit:— J. T. Enright—Woodfield Park	2 10 0
		The Park Supplies—Sunny Hill	5 0 0
5th May	610	Camp Permit—War Office	1 0 0
5th May	610	Latrines—Moat Mount Camp	850 0 0
5th May	673	Tractor—Spurling Motors Ltd.	615 2 0
5th May	673	Fencing in 8 Parks—Provo Bros. Ltd.	158 12 11
19th June	773	Pavilion and Lavatories, Edgwarebury Park—J. N. Jones	1900 0 0
19th June	773	Bandstand—Watling Park—G. H. Kempster Ltd.	479 0 0
19th June	811	Park Entertainments (3)—A. Potter	9 9 0
19th June	770	Sale of Refreshments—Silk Stream Park—H. W. Daniel	2 0 0
Highways:—			
5th May	611	Surfacing Carriageways:—Devonshire Road and Crescent, Aberdare Gardens and Osborne Gardens—G. Wimpey & Co. Ltd.—per square yard	3 10
		Surfacing Margins:—Devonshire Road and Crescent, Aberdare Gardens and Osborne Gardens—G. Wimpey & Co. Ltd.—per square yard	3 3
5th May	670	Supply of Tarmacadam and Tarpaving—Constable Hart & Co. Ltd.—per ton	£1 2 11 to £1 5 3
8th May	667	Making up Southover—C. Carter	684 11 1
19th June	773	Surfacing Southover—Constable, Hart & Co. Ltd.—per square yard	3 11
19th June	772	Road Dressings:—Asphalt Construction Ltd., McCreath Taylor & Co. Ltd., T. Hill Jones Ltd. and Situsec Ltd.—per gallon	6½
Works and Fire Brigade:—			
5th May	611	Repairs to Ambulance, BML 945—Sunbeam Talbot Ltd.	82 2 0
19th June	772	Fuel Oil—Anglo-American Oil Co. Ltd.—Wholesale, less rebate of	¼d. per gallon
19th June	773	Talbot Ambulance—"K" Garage & Service Station Ltd.	415 13 6
19th June	818	Hut—"Fenella"—H. Pickrill	505 0 0
Public Health:—			
5th May	660	Subscription—Health and Cleanliness Council	1 1 0
Air Raid Precautions:—			
5th May	640	Clothing for Auxiliary Fire Service	1172 1 0
5th May	640	Hire of Vehicles for Test Mobilisation	5 5 0
5th May	707	Six One-ton Vans—each	15 0 0
5th May	707	Three Stretcher Racks	5 10 0
5th May	707	Lease of Archway for Sandbag Store—London Passenger Transport Board—per annum exclusive	30 0 0
5th May	708	Equipment for Medical Services	48 0 0

QUOTATIONS ACCEPTED, CONTRACTS, LET, ETC.—Contd.:

Date of Minute.	Minute Folio.	Particulars.	Amount of Contract.
Education:—			
			£ s. d.
8th May	611	Fuel—J. Hudson & Co. Ltd.:—	
		Peas—per ton	1 12 6
		Singles—per ton	1 13 6
8th May	647	Fire Extinguishers—Dole Street School—Nuswift Engineering Co. Ltd.	23 8 0
8th May	648	Repairs Electric Circuits—Meads School	85 0 0
19th June	791	Hendon Schools' Sports Association—Grant.....	100 0 0
19th June	791	National Society for Prevention of Cruelty to Children—Donation	5 5 0
19th June	796	National Association Juvenile Employment and Welfare Officers—Subscription	1 1 0
19th June	796	Roofing, Burnt Oak School—Roberts and Burling Ltd.	399 13 3
Buildings and Town Planning:—			
19th June	827	Engel Park Communicating Street—Site—Park Estates Ltd.	201 12 0

Amount of
Contract.

£ s. d.

1 12 6
1 13 6

23 8 0

85 0 0

100 0 0

5 5 0

1 1 0

99 13 3

01 12 0



Borough of Hendon.

NOTICE IS HEREBY GIVEN

That a Special Meeting of the Council of the Borough of Hendon, in the County of Middlesex, will be held on **Monday** next, the **18th** day of **September, 1939**, at **6** o'clock in the afternoon, at the Town Hall, The Burroughs, Hendon, N.W. 4, and all and several the Members of the said Council are hereby summoned to attend.

The business to be transacted at such meeting is as follows:—

1. To confirm Minutes of the Ordinary Meeting of the Borough Council held on the 17th day of July, 1939.
2. Official Announcements.
3. To receive the Mayor's Report as to action taken during the Summer Recess.
4. Reports (if any) of Officers.
5. To take such action as may be necessary for the transaction of Local Government business for the period to the 9th November next.

Town Clerk.

Town Clerk's Office,
Hendon, N.W. 4.

13th September, 1939.

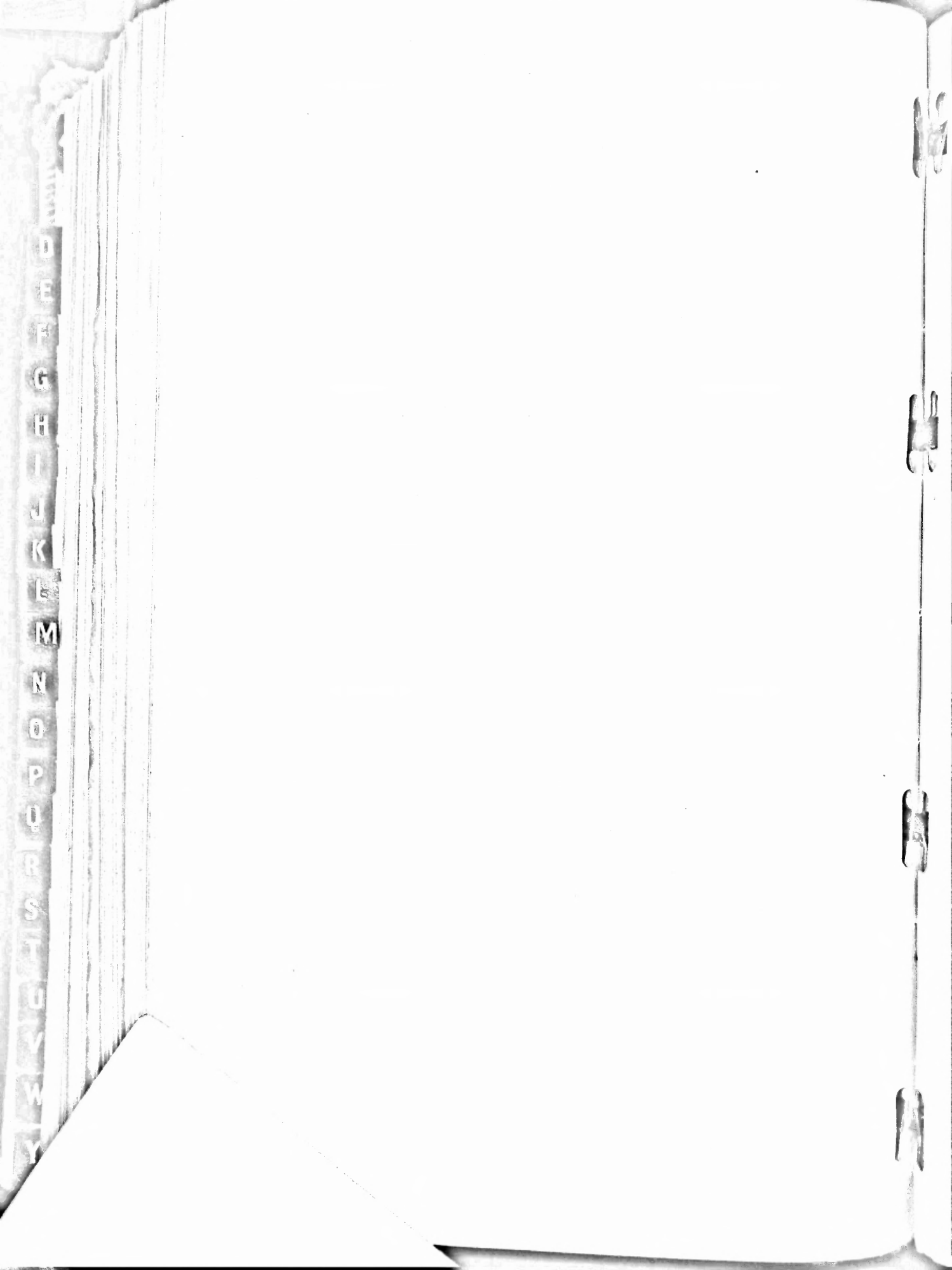

Minutes.

At an Ordinary Meeting of the COUNCIL of the BOROUGH OF HENDON, held at the Town Hall, The Burroughs, Hendon, N.W. 4, on Monday, the 17th day of July, 1939, at 6 o'clock p.m.

PRESENT:

His Worship the Mayor (Councillor H. C. Potter, J.P., F.S.I.), *in the Chair.*

The Deputy Mayor (Alderman S. H. Egan, J.P.).

Aldermen:

W. R. Clemens, F.C.A.,
J. J. Copestake, J.P.,

W. M. Maughan, J.P.,
A. J. Reynolds, J.P.,

F. C. Rice.
R. A. B. Teare, M.B.E.

Councillors:

E. Arter, M.C., M.I.A.E.,
F. H. Bate,
T. K. Bridge,
F. J. Collins,
H. Connell, J.P.,
E. J. Cox,
A. W. Curton,
F. W. Gilpin,
A. W. Creville,

J. Griffiths,
W. A. Hicks,
C. H. Hignett,
L. Hirshfield,
P. Lightfoot,
A. A. Naar, M.B.E.,
(Mrs.) F. E. Parvin,
C. Pinkney,

G. J. Pryke, F.I.A.C.,
A.M.I.S.E.,
T. Pugh,
C. R. Richardson,
J. H. Rodway,
T. J. Scott,
W. H. N. Shakespeare,
M.C., A.F.C., J.P.,
H. P. Small,
(Mrs.) M. Thomas,

NOTICE OF MEETING:

The Town Clerk read the notice convening the Meeting.

MINUTES—CONFIRMATION:

Moved by Alderman Reynolds, seconded by Councillor Bate, and

322.—RESOLVED—That the Minutes of the Statutory Meeting of the Borough Council held on the 19th June, 1939, be confirmed.

DEATH OF ALDERMAN B. J. MONRO:

His Worship the Mayor paid tribute to the late Alderman B. J. Monro, in the following terms:—

Mr. Deputy Mayor, Aldermen and Councillors.

It is my very regrettable duty to refer to the death on Sunday, the 9th July, of our colleague, Alderman B. J. Monro, whose burial, as you know took place on Thursday last.

This sad event was, perhaps, not unexpected as we had all, I think, been conscious of his increasing weakness during the last few months and had admired the courageous way in which he had, in spite of considerable suffering, endeavoured to carry on business and particularly his public duties.

Alderman Monro was elected to the Urban District Council of Hendon in April of 1926, and in the same year Mr. Charles Latham (now in another sphere of public service) and myself were returned to the Council.

In the Council Chamber, Alderman Monro seldom spoke, and for that reason perhaps his words carried the more weight when he did intervene. If his Council work were judged on this basis many would fail to do justice to his achievements, because it was in Committee and at other proceedings of a private character where his services were most useful and indeed invaluable.

The list of Committees upon which he served is a summary of the work of the Council. They included the

Buildings and Town Planning Committee,
 Estates, Parks and Allotments Committee,
 Highways Committee,
 Housing Committee,
 Libraries and Local Pensions Committee,
 Public Health and Medical Services Committee,
 Works and Fire Brigade Committee (Chairman, 1929/31),
 Finance and General Purposes Committee (Chairman, 1933/35),
 Education Committee (Chairman, 1936/38).

It was, perhaps, upon the last two Committees that his business acumen was most conspicuous and useful. I feel that the Members of the Education Committee would wish me to stress his immense service to the cause of education, especially as it was at a time when the rapidly increasing child population called for a broadminded and far seeing policy of development to lay an adequate foundation upon which to advance the educational system of the Borough.

His abilities were further recognised by his appointment to the Hendon Local Higher Education Committee, of which he was Chairman from 1936 to 1938.

His anxiety for the after care of the pupils was evidenced by his work on the Juvenile Employment Committee.

The experience he had gained in his own youthful sporting triumphs was readily placed at the disposal of the Juvenile Organisation Committee of which he was the President in the years 1936 to 1938, and the trophies he presented to this organisation or to Clubs affiliated to it will keep alive his name and memory for many years.

To quote what was written for another occasion:—

“Special Committees... which have also received the advantage of his well considered advice included:—

Emergency Committee (Chairman, 1932),
 Incorporation Committee,
 Boundaries Committee,
 Development Committee.”

In 1932 with the question of Incorporation before the Council he was elected Chairman of the Urban District Council, and on the 15th August of that year His Majesty the King granted the Charter incorporating Hendon as a Municipal Borough.

In response to the wishes of the Council he undertook the onerous duties of Charter Mayor and subsequently first Mayor of the newly incorporated Borough. In that office he established a standard to which the town owes much of its present dignity and prestige.

To him, the Borough is also indebted for the Corporation's Regalia, which will remain for all time as a permanent tribute to his interest in the District which he has served so well.

He was elected an Alderman in June, 1935, and on the 9th November of 1938, he entered on a further period of office for six years in the same capacity.

On the 20th December, 1938, the Council conferred on Alderman *Monro* the Honorary Freedom of the Borough, an act which, I know, gave him the greatest possible pleasure. It will also be a cherished memory with me that it was through my hands that he received the Council's beautiful illuminated script conferring on him the highest honour which it is their privilege to bestow, together with the casket. In his speech that evening he expressed the hope that he might justify the presentation by his future work. Unfortunately for us, that period has been all too short.

I do not think that I need hesitate now to say that at the time of the presentation of the Honorary Freedom the Doctors were gravely concerned and feared the worst would be inevitable at a comparatively early date, but since then seven weary and trying months have elapsed until the end came last Sunday week.

His last attendance at the Council was on the 8th May. Of his charming personality I need not speak at length but it permeated his dealings with his fellow Aldermen and Councillors. He had no enemies on the Council. His judgments were based on the merits of each case—he was a sympathetic listener and a ready helper, and in his death we have lost not only an eminent public man but also a warmhearted friend.

Following the Mayor's tribute, the Members of the Council and all present stood for a brief period in silence, after which His Worship moved the following Motion which was seconded by the Deputy Mayor (Alderman *Egan*):—

THAT the Council of the Borough of Hendon in expressing their profound regret at the untimely death of

Alderman *Bertrand John Monro* (Charter Mayor, First Mayor and Honorary Freeman of the Borough)

place on record their deep appreciation of the valuable service which he has ungrudgingly rendered to the public during so many years both as a Member of the Council and in other capacities, and

Do hereby convey to Mrs. *Monro* and her family their sincerest sympathy in the irreparable loss which they have sustained.

Several members spoke in support of the motion which, on being submitted, was declared **carried** unanimously.

323.—Accordingly **RESOLVED**—That the Council of the Borough of Hendon in expressing their profound regret at the untimely death of

Alderman *Bertrand John Monro* (Charter Mayor, First Mayor and Honorary Freeman of the Borough)

place on record their deep appreciation of the valuable service which he has ungrudgingly rendered to the public during so many years both as a Member of the Council and in other capacities, and

Do hereby convey to Mrs. *Monro* and her family their sincerest sympathy in the irreparable loss which they have sustained.

OFFICIAL ANNOUNCEMENT:

The Mayor expressed pleasure on the return to the Council of the Deputy Mayor (Alderman S. H. Egan, J.P.) and Councillor (Mrs.) Thomas after some months absence on account of illness.

His Worship the Mayor also intimated that Alderman Brook Flowers' condition showed a slight improvement but that his progress was very slow.

VISIT OF SCHOOL CHILDREN:

His Worship the Mayor extended a welcome to a party of senior scholars from the Garden Suburb Council School who were in attendance under the charge of their mistress.

REPORTS OF COMMITTEES.

EDUCATION COMMITTEE:

Moved by Alderman Copestake, seconded by Councillor Bate, and

324.—RESOLVED—That the report of the Education Committee (Meeting held on the 4th July, 1939—Agenda, pages 894-910) be received.

Page 897—Item 8—A.R.P. Evacuation of School Children.

In reply to Councillor Gilpin who enquired as to the present position in relation to evacuation of school children, the Chairman of the Education Committee (Alderman Copestake) stated that an intimation had been received from the Ministry of Health that Hendon was not to be included in the areas scheduled for evacuation.

The Mayor also intimated that consequent upon the enlargement of the evacuation areas from which Hendon had been excluded, he had again written to the Minister of Health on the matter.

ADOPTION OF REPORT: Moved by Councillor Copestake, seconded by Councillor Bate, and

325.—RESOLVED—That the report of the Committee, in so far as it relates to matters requiring the confirmation of the Council, be approved and adopted.

PUBLIC HEALTH AND MEDICAL SERVICES COMMITTEE:

REPORT NO. 1.

Moved by Councillor Scott, seconded by Councillor Curton, and

326.—RESOLVED—That Report No. 1 of the Public Health and Medical Services Committee (Meeting held on the 26th June, 1939—Agenda, pages 911-919) be received.

ADOPTION OF REPORT: Moved by Councillor Scott, seconded by Alderman Maughan, and

327.—RESOLVED—That Report No. 1 of the Public Health and Medical Services Committee be approved and adopted.

REPORT NO. 2.

Moved by Councillor Scott, seconded by Alderman Maughan, and

328.—RESOLVED—That the following report be received:—

REPORT (NO. 2) OF THE
PUBLIC HEALTH AND MEDICAL SERVICES COMMITTEE.

11th July, 1939.

COMMITTEE:

*Councillor T. J. Scott (*Chairman*).

Aldermen:

W. R. Clemens, F.C.A., B. Flowers, *W. M. Maughan, J.P.

Councillors:

*F. W. Gilpin, *P. Lightfoot, H. P. Small,
*G. H. Hignett, C. Pinkney, (Mrs.) M. Thomas.
L. Hirshfield, C. R. Richardson,

Co-opted Members:

Mrs. S. J. Bannister, *Mrs. W. M. Maughan, *The Rev. P. C. Howell,
L.L.A., Mrs. B. J. Monro, J.P.,

* denotes Member present.

ASSISTANT MEDICAL OFFICER:

The Committee interviewed the following applicants selected by the Chairman and the Medical Officer of Health:— (P.H. & M.S.C., 26/6/39—5.)

Dr. N. L. Lewis, Greenford.
Dr. K. M. Bodkin, Cambridge Park, E. 11.
Dr. V. N. Leyshon, Bayswater.
Dr. D. G. Sharvelle, Hull.
Dr. J. D. Whyte, London, N.W. 3.

RESOLVED TO RECOMMEND—

- (1) That subject to the receipt of a satisfactory medical report, Dr. Kathleen M. Bodkin, M.R.C.S., L.R.C.P., D.P.H., Assistant Medical Officer, Essex County Council be appointed on the permanent staff to the post of Assistant Medical Officer of Health and Assistant School Medical Officer at a commencing salary of £600 per annum, rising by annual increments of £25 to a maximum of £750, the engagement to be determinable by one month's notice on either side.
- (2) That in the event of the appointment not being taken up by Dr. Bodkin, the post be offered to Dr. Jean Duncan Whyte (Locum Brighton County Borough Mental Hospital).

ADOPTION OF REPORT: Moved by Councillor Scott, seconded by Alderman Maughan, and

329.—RESOLVED—That Report No. 2 of the Public Health and Medical Services Committee be approved and adopted.

HIGHWAYS COMMITTEE:

Moved by Councillor Curton, seconded by Councillor Copestake, and

330.—RESOLVED—That the report of the Highways Committee (Meeting held on the 26th June, 1939—Agenda, pages 920-926) be received.

Page 923—Item 12—Barrier Rails, Golders Green Cross Roads.

AMENDMENT moved by Councillor Cox, seconded by Councillor Scott:—

THAT 72 feet be substituted for 90 feet where it appears in line 4 of the Committee's recommendation.

After discussion, the amendment was submitted and declared **lost**.

FURTHER AMENDMENT moved by Alderman Clemens, seconded by Alderman Copestake:—

THAT, subject to the approval of the Minister of Transport and the Middlesex County Council, the scheme of barrier rails be modified to provide for the termination of the rails at points in Golders Green Road, 90 feet from the junction of the Cross Roads, and at points immediately opposite to and including Nos. 638 and 887, Finchley Road in a southerly direction in the Finchley Road.

Debate ensued.

MOTION moved by Alderman Maughan, seconded by Alderman Teare:—

THAT the Council proceed to the next business.

The motion, on being submitted, was declared **lost**.

The amendment moved by Alderman Clemens was thereupon put and declared **carried**, 19 voting for and 7 against.

SUBSTANTIVE MOTION: Upon submission as a substantive motion, it was declared **carried**.

331.—Accordingly **RESOLVED—That, subject to the approval of the Minister of Transport and the Middlesex County Council, the scheme of barrier rails be modified to provide for the termination of the rails at points in Golders Green Road 90 feet from the junction of the Cross Roads, and at points immediately opposite to and including Nos. 638 and 887, Finchley Road in a southerly direction in the Finchley Road.**

Page 925—Item 20—Edgwarebury Lane Improvement (Parkside Drive to Hartland Drive).

AMENDMENT moved by Alderman Clemens, seconded by Alderman Copestake:—

THAT the following words be added to the Committee's recommendation:—

“Subject to the execution of the intended Agreement with John Laing and Sons Limited.”

On submission, the amendment was declared **carried**.

332.—Accordingly **RESOLVED—That the Council take over the responsibility for the future maintenance and repair of the section of the road in question subject to the execution of the intended Agreement with John Laing & Sons Limited.**

Page 925—Item 22—Station Road, Edgware.

On consideration of the above Item, Councillor Shakespeare suggested that when the question of the re-construction of the portion of Station Road, Edgware, between the Station and High Street, comes up for consideration, due regard should be given to the possibility of reducing the width of the footpaths and constructing a central island 4 feet in width along the whole length of the road.

The Chairman of the Highways Committee (Councillor Curton) intimated that the suggestion would be borne in mind when the re-construction of the remaining portion of Station Road, Edgware comes before the Committee.

Junction, North Circular Road and Hendon Way—Fly-over.

The Chairman of the Committee (Councillor Curton) reported that the deputation appointed by the Council had been received by the Minister of Transport and that the Minister, after hearing the representations put forward by the deputation, had agreed to the removal of the round-about at this junction and the installation of a system of traffic light signal control and that the work would be put in hand forthwith.

Alderman Copestake reported that the matter had been considered by the Middlesex County Council and that that Authority were preparing the necessary plans for the approval of the Minister of Transport.

ADOPTION OF REPORT: Moved by Councillor Curton, seconded by Alderman Copestake, and

- 333.—RESOLVED—That the report of the Highways Committee, as amended, be approved and adopted.

ESTATES, PARKS AND ALLOTMENTS COMMITTEE:

Moved by Councillor Collins, seconded by Councillor (Mrs.) Parvin, and

- 334.—RESOLVED—That the report of the Estates, Parks and Allotments Committee (Meeting held on the 26th June, 1939—Agenda, pages 929-931) be received.

Page 927—Item 5—Edgwarebury Park.

AMENDMENT moved by Councillor Shakespeare, seconded by Councillor Curton:—

THAT the following words be added to Recommendation 1:—

“and that the Borough Engineer be instructed to obtain tenders for the provision of a bowling green in Edgwarebury Park in accordance with the plans submitted and provisionally agreed by the Committee 12 months ago.”

After discussion, and statements by the Chairman of the Committee and the Borough Treasurer, Councillor Shakespeare, with the consent of his seconder and of the Council, agreed to withdraw his amendment on an undertaking being given by the Chairman of the Committee that plans and estimates for the provision of a bowling green at Edgwarebury Park would be submitted to the next meeting of the Committee.

Amendment accordingly **withdrawn**.

ADOPTION OF REPORT: Moved by Councillor Collins, seconded by Councillor Teare, and

- 335.—RESOLVED—That the report of the Estates, Parks and Allotments Committee be approved and adopted.

WORKS AND FIRE BRIGADE COMMITTEE:

Moved by Councillor Naar, seconded by Councillor (Mrs.) Parvin, and

- 336.—RESOLVED—That the report of the Works and Fire Brigade Committee (Meeting held on the 3rd July, 1939—Agenda, pages 932-940) be received.

Page 932—Item 4—Resignation of Fireman.

Discussion ensued on consideration of the above item and the Chairman of the Committee reported on the present position of the Council's application for consent to the erection of the proposed new Central Fire Station.

Page 937—Item 26—Training Facilities.

AMENDMENT moved by Alderman Clemens, duly seconded:—

THAT the following be added to the Committee's recommendations:—

- “ (3) That any proposals involving expenditure under recommendations (1) and (2) be submitted for the approval of the Home Office.”

The amendment, on being submitted was declared **carried**.

337.—Accordingly RESOLVED—

- (1) **That the Fire Superintendent be authorised to negotiate with a view to obtaining the use of the buildings referred to for Divisional Headquarters for training and recreational facilities.**
- (2) **That, subject to the approval of the Education Committee, the above-mentioned school playgrounds be used for drill purposes and lock-ups for the storage of training equipment be provided.**
- (3) **That any proposals involving expenditure under recommendations (1) and (2) be submitted for the approval of the Home Office.**

The Chairman intimated that two of the schools referred to in the Committee's recommendation would not be available for the purposes suggested by the Committee.

Page 938—Item 33—Refuse Collecting Vehicles.

AMENDMENT moved by Alderman Riee, seconded by Councillor Shakespeare:—

THAT the above matter be referred back for further consideration.

On submission, the amendment was declared **carried**.

338.—Accordingly RESOLVED—**That Item 33 of the report of the Works and Fire Brigade Committee be referred back for further consideration.**

ADOPTION OF REPORT: Moved by Councillor Naar, seconded by Councillor Gilpin, and

339.—RESOLVED—**That the report of the Works and Fire Brigade Committee, as amended, be approved and adopted.**

LIBRARIES AND LOCAL PENSIONS COMMITTEE:

Moved by Councillor Lightfoot, seconded by Alderman Teare, and

340.—RESOLVED—**That the report of the Libraries and Local Pensions Committee (Meeting held on the 3rd July, 1939—Agenda, pages 941-945) be received.**

ADOPTION OF REPORT: Moved by Councillor Lightfoot, seconded by Councillor Scott, and

341.—RESOLVED—**That the report of the Libraries and Local Pensions Committee be approved and adopted:**

HOUSING COMMITTEE:

Moved by Councillor Gilpin, seconded by Councillor Scott, and

342.—RESOLVED—**That the report of the Housing Committee (Meeting held on the 3rd July, 1939—Agenda, pages 946-949) be received.**

ADOPTION OF REPORT: Moved by Councillor Gilpin, seconded by Councillor Maughan, and

343.—RESOLVED—**That the report of the Housing Committee be approved and adopted.**

BUILDINGS AND TOWN PLANNING COMMITTEE:

Moved by Councillor Hignett, seconded by Councillor Shakespeare, and

- 344.—RESOLVED—That the report of the Buildings and Town Planning Committee (Meeting held on the 3rd July, 1939—Agenda, pages 959-961) be received.

ADOPTION OF REPORT: Moved by Councillor Hignett, seconded by Councillor Naar, and

- 345.—RESOLVED—That the report of the Buildings and Town Planning Committee be approved and adopted.

RATING AND VALUATION COMMITTEE:

Moved by Councillor Small, seconded by Councillor Curton, and

- 346.—RESOLVED—That the report of the Rating and Valuation Committee (Meeting held on the 11th July, 1939—Agenda, page 962) be received.

AIR RAID PRECAUTIONS COMMITTEE:

REPORT NO. 1.

Moved by Councillor Arter, seconded by Councillor Curton, and

- 347.—RESOLVED—That Report No. 1 of the Air Raid Precautions Committee (Meeting held on the 27th June, 1939—Agenda, pages 963-970) be received.

Page 966—Item 16—Collective Training for First Aid Posts.

AMENDMENT moved by Alderman Clemens, seconded by Alderman Copestake:—

THAT the following words be inserted after the word "THAT" in the first line of the recommendation:—

"subject to the approval of the Middlesex County Council to the expenditure estimated at £50."

On being submitted, the amendment was declared **carried**.

- 348.—Accordingly RESOLVED—That, subject to the approval of the Middlesex County Council to the expenditure estimated at £50, the adaptation work to be carried out at the Health Centre, Hartley Avenue, Mill Hill, for the purpose of a First Aid Post, be put in hand forthwith, and that the Medical Officer of Health be authorised to make arrangements for suitable accommodation to be available in other parts of the Borough for the purpose of the collective training of First Aid Post Staffs.

Page 969—Item 22—Divisional Wardens—Clerical Assistance.

The Chairman stated that consequent upon the re-organisation of the Wardens' Service the above recommendation would not be put into effect.

Page 969—Item 24—Course of Instruction for L.A.R.P. Instructors.

AMENDMENT moved by Councillor Pinkney, seconded by Alderman Maughan:—

THAT the following words be added to the Committee's recommendation:—

"and that the services of Mr. R. E. Stimpson be utilised for instructional purposes."

On submission, the amendment was declared **not carried**, whereupon a division was demanded by Councillor Pugh and two other members and taken with the following result:—

	For 11.	Against 13.	Abstained from Voting 8.	Absent when Division taken 3.
Alderman	Maughan.	The Deputy Mayor.	The Mayor.	Alderman Flowers.
"	Teare.	Alderman Copestake.	Alderman Clemens.	Councillor Connell.
Councillor	Bridge.	" Rice.	" Reynolds.	" Windust.
"	Cox.	Councillor Bate.	Councillor Arter.	
"	Griffiths.	" Collins.	" Curton.	
"	Hirshfield.	" Gilpin.	" Greville.	
"	Pinkney.	" Hicks.	" Naur.	
"	Pugh.	" Hignett.	" Pryke.	
"	Richardson.	" Lightfoot.		
"	Rodway.	" (Mrs.) Parvin.		
"	Scott.	" Shakespeare.		
"		" Small.		
"		" (Mrs.) Thomas.		

Page 970—Item 30—Canteens for Air Raid Precautions Personnel.

AMENDMENT moved by Councillor Pugh, seconded by Councillor Pinkney:—
THAT the above item be referred back.

SUSPENSION OF MEMBER:

During the course of subsequent discussion, Councillor Richardson protested against a statement made by Councillor Curton, such protest, in the opinion of the Mayor, being couched in terms which contravened Standing Order No. 35. Upon being called upon by the Mayor to withdraw the offending statement, Councillor Richardson refused, whereupon, in accordance with Standing Order No. 36, the Mayor "named" the offending member and moved:—

THAT the offending member be suspended from the sitting of the Council.

349.—The motion, on being submitted was declared **carried**, whereupon Councillor Richardson left the Council Chamber.

The amendment for the reference back of Item 30 of the Committee's report, was submitted and declared **lost**.

ADOPTION OF REPORT: Moved by Councillor Arter, seconded by Councillor Curton, and

350.—RESOLVED—That Report No. 1 of the Air Raid Precautions Committee, as amended, be approved and adopted.

REPORT NO. 2.

Moved by Councillor Arter, seconded by Councillor Curton, and

351.—RESOLVED—That Report No. 2 of the Air Raid Precautions Committee (Meeting held on the 3rd July, 1939—Agenda, page 971) be received.

Lengthy discussion ensued, and to enable the Chairman of the Committee to report for information what had transpired at two subsequent meetings of the Special (Air Raid Precautions) Sub-Committee, it was

Moved by Councillor Gilpin, seconded by Councillor Bridge, and

352.—RESOLVED—That, for the purposes of this Meeting of the Borough Council, Standing Order No. 15 in so far as it precludes a Sub-Committee from reporting direct to the Council, be suspended.

The Chairman of the Committee (Councillor Arter) thereupon gave a resumé of the matters considered, and the decisions arrived at, by the Special (Air Raid Precautions) Sub-Committee, at their meetings held on the 5th and 11th July.

Constitution of Special (Air Raid Precautions) Sub-Committee.

AMENDMENT moved by Councillor Scott, seconded by Councillor Bridge:—

THAT recommendation (b) be amended by the addition of the Chairman of the Public Health and Medical Services Committee on the Special (Air Raid Precautions) Sub-Committee.

Subsequently withdrawn.

AMENDMENT moved by Alderman Reynolds, seconded by Alderman Teare:—

THAT recommendation (b) be amended by the addition of the names of the Chairman of the Public Health and Medical Services Committee (Councillor Scott) and Councillor Curton to the Special (Air Raid Precautions) Sub-Committee.

On submission, the amendment was declared **carried**.

CONSEQUENTIAL AMENDMENT: Consequent upon the adoption of the foregoing amendment, recommendation (d) was accordingly deleted.

353.—RESOLVED—

- (a) That Mr. F. H. Day of the Public Health Department be seconded for duty with the Air Raid Precautions Officer for a period of one month and the position reviewed at the expiration of this period.
- (b) That a Special (Air Raid Precautions) Sub-Committee be appointed consisting of:—

His Worship the Mayor,

The Chairman (Councillor E. Arter, M.C., M.I.A.E.),

Councillor A. A. Naar, M.B.E.,

Councillor C. Pinkney,

Councillor T. J. Scott (Chairman of the Public Health and Medical Services Committee),

Councillor A. W. Curton,

to whom shall be delegated the powers and duties of the Council under the Air Raid Precautions Act, 1937 (except Air Raid Fire Precautions), subject to the submission of reports on the action taken to the Council through the Air Raid Precautions Committee to be convened as and when considered necessary by the Special (Air Raid Precautions) Sub-Committee.

ADOPTION OF REPORT: Moved by Councillor Arter, seconded by Councillor Curton, and

354.—RESOLVED—That Report No. 2 of the Air Raid Precautions Committee, as amended, be approved and adopted.

FINANCE AND GENERAL PURPOSES COMMITTEE:

Moved by Alderman Clemens, seconded by Alderman Copestake, and

355.—RESOLVED—That the report of the Finance and General Purposes Committee (Meeting held on the 10th July, 1939—Agenda, pages 972-982) be received.

ADOPTION OF REPORT: Moved by Alderman Clemens, seconded by Councillor Shakespeare, and

356.—RESOLVED—That the report of the Finance and General Purposes Committee be approved and adopted.

SEALING OF DOCUMENTS:

Moved by Alderman Reynolds, seconded by Alderman Copestake, and

357.—RESOLVED—That the Corporate Seal be affixed to the following documents:—

Deed of Apprenticeship	Mr. S. Goodrich and D. J. Goodrich, Junior, and the Corporation— for training and instruction in gardening.
Deed of Apprenticeship	Mr. J. Lovatt and D. Lovatt, Junior, and the Corporation— for training and instruction in gardening.
Counterpart Agreement	London Passenger Transport Board and the Corporation— as to tenancy of Underground Railway Arch at Burnt Oak.

SUMMER RECESS:

Moved by the Deputy Mayor (Alderman Egan), seconded by Alderman Clemens, and

358.—RESOLVED—That His Worship the Mayor, or in his absence the Deputy Mayor, be vested with power to deal with all urgent matters which may arise during the Summer Recess, i.e., 18th July to the 18th September.

The Meeting terminated at 9.10 p.m.

Herbert G. Taylor

Mayor



Borough of Hendon.

NOTICE IS HEREBY GIVEN

That a Statutory Meeting of the Council of the Borough of Hendon, in the County of Middlesex, will be held on **Monday** next, the **9th** day of **October, 1939**, at **6** o'clock in the afternoon, at the Town Hall, The Burroughs, Hendon, N.W. 4, and all and several the Members of the said Council are hereby summoned to attend.

The business to be transacted at such meeting is as follows:—

1. To confirm Minutes of the Special Meeting of the Borough Council held on the 18th September, 1939.
2. Official Announcements.
3. Election of Alderman.
4. Questions.
5. To approve, or otherwise, the Reports of the following Committees, viz.:—
Education, and Emergency (Local Government) Committee [F. & G.P.C.].
6. Report of Emergency Committee.
7. To authorise the sealing of the following documents:—

Power of Attorney	To authorise the receipt of monies due to the Corporation in an action—The Corporation v. Bowen.
Mortgage	The Corporation and the Trustees of the Boilermakers Iron and Steel Shipbuilders Society—to secure loan of £10,000 and interest.
Indemnity	To Barclays Bank Limited relating to the release of deposited monies in respect of road charges on land in Marion Road, Mill Hill.

8. Reports (if any) of Officers.

9. Recess Powers.

TO RESOLVE—That His Worship the Mayor, or in his absence the Deputy Mayor, be vested with power to deal with all urgent matters which may arise during the interim to the 9th November, 1939.



Leonard Warden

Town Clerk.

Town Clerk's Office,

Hendon, N.W. 4.

4th October, 1939.

the Deputy
which may

on Clerk.

INDEX.



MINUTES Page 995 to 1028

REPORTS:

Education Committee 1029 to 1046

Emergency (Local Government) Committee [F. & G.P.C.] — „ 1047 to 1079

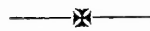

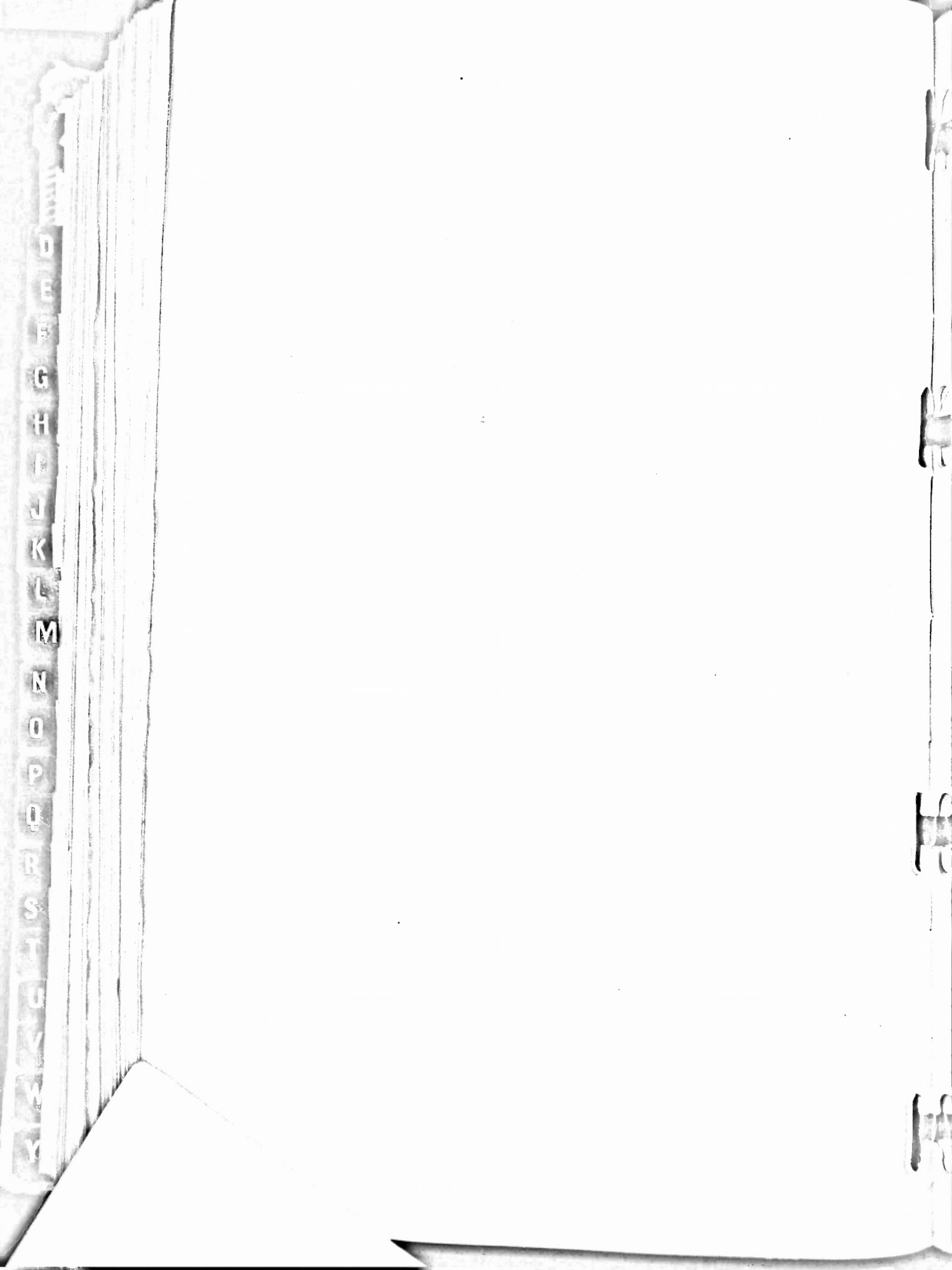

Minutes.

At a Special Meeting of the COUNCIL of the BOROUGH OF HENDON, held at the Town Hall, The Burroughs, Hendon, N. W. 4 on Monday, the 18th day of September, 1939, at 6 o'clock p.m.

PRESENT:

His Worship the Mayor (Councillor H. C. Potter, J.P., F.S.I.), *in the Chair.*

The Deputy Mayor (Alderman S. H. Egan, J.P.).

Aldermen:

**W. R. Clemens, F.C.A.,
J. J. Copestake, J.P.,**

**W. M. Maughan, J.P.,
A. J. Reynolds, J.P.,**

R. A. B. Teare, M.B.E.

Councillors:

**E. Arter, M.C., M.I.A.E.,
F. H. Bate,
T. K. Bridge,
F. J. Collins,
H. Connell, J.P.,
E. J. Cox,
A. W. Curton,
A. W. Greville,
J. Griffiths,**

**W. A. Hicks,
G. H. Hignett,
L. Hirshfield,
P. Lightfoot,
A. A. Naar, M.B.E.,
(Mrs.) F. E. Parvin,
C. Pinkney,
G. J. Pryke, F.I.A.C.,
A.M.I.S.E.,**

**T. Pugh,
G. R. Richardson,
T. J. Scott,
W. H. N. Shakespeare,
M.C., A.F.C., J.P.,
H. P. Small,
(Mrs.) M. Thomas,
G. F. Windust.**

NOTICE OF MEETING:

The Town Clerk read the Notice convening the Meeting.

MINUTES—CONFIRMATION:

Moved by Alderman Reynolds, seconded by Alderman Copestake, and

359.—RESOLVED—**That the Minutes of the Ordinary Meeting of the Borough Council held on the 17th day of July, 1939, be confirmed.**

APOLOGIES FOR ABSENCE:

Apologies for absence were submitted on behalf of Alderman F. C. Rice and Councillor F. W. Gilpin.

RECESS (SUMMER) REPORT:

360.—RESOLVED—**That the following report be received:—**

To the Aldermen and Councillors,
Borough of Hendon.

Ladies and Gentlemen,

When the Council rose on the 17th July for the Summer Recess, it had taken the step, in view of the circumstances then existing, of appointing an Air Raid Precautions Committee, and this Committee had in its turn appointed a Special Sub-Committee of five Members with power to act.

The Middlesex County Council, being the Scheme making Authority for the Borough, had requested the Hendon Council to nominate a Controller and to elect an Emergency Committee under the terms of the Air Raid Precautions Department Circular No. 57/1939 of the 21st March, 1939, as amplified by London Region Circular No. 18 of August, 1939, with wide powers in time of war to act on their behalf in matters of Civil Defence. This the Borough Council did.

On the 31st August instructions were received for the Controller and the Emergency Committee to assume their duties. A state of war was declared on the 3rd instant. The Special (Air Raid Precautions) Sub-Committee thereupon ceased to function and the operative proceedings of the Sub-Committee prior to the 31st August are merged in the report of the Emergency Committee presented for information this evening.

The report which the Chairman of the Emergency Committee is presenting will, I understand, give the Council a summary of the Civil Defence Services, from which you will appreciate the enormous amount of work done by the Special Sub-Committee and the existing Emergency Committee.

It is right, I think, that I should refer to the work of the Chief Officers, the Controller and their staffs. The Officers, upon whom falls an enormous amount of the work for protecting the civil population, have laboured incessantly to cope with the various duties thrust upon them, remaining at their work for many hours a day, and some of them undertaking all night supervision in addition. The thanks of the Council are due to all Grades engaged in these important Services.

Although a large portion of the Air Raid Precautions organisation is now worked by paid assistance, I must also gratefully acknowledge the valuable and extensive work which is still being done, and will in future be done, by voluntary help. It is not too much to say that without this help the various Civil Defence Services would have been considerably hampered.

In visiting various parts of the Borough I have been asked by and on behalf of the children from the closed Elementary Schools to find something for the children to do in the day-time. It is a difficult question but I have asked the Chairman of the Education Committee to consider if anything can be done in the matter.

I was approached with a view to setting up a Bureau of Information and this work is now being carried out by a Voluntary Committee working in conjunction with the Charity Organisation Society with offices at 130, Station Road, N.W. 4.

The following matters have been dealt with under authority of the Council's resolution No. 358 of the 17th July:—

1.—OLD AGE PENSIONS:

6 Claims and 3 Questions considered and decisions given having the following effect:—

Claims:—

5 allowed at the full rate of 10/- weekly.

1 disallowed, yearly means exceeding £49 17s. 6d.

—
6
—

Questions:—

1 Pensioner not entitled to any pension as from 12th May, 1939.

1 Pensioner entitled to a pension at the rate of 2/- weekly as from 12th July, 1939, instead of 6/-.

1 Pensioner has been from and including 11th July, 1939, disqualified by reason of being detained in a Mental Hospital.

—
3
—

2.—FOOD CONTROL COMMITTEE:

Government instructions having been issued for steps to be taken to form a Food Control Committee for the Borough of Hendon, the Borough Treasurer, who is acting as Food Executive Officer, approached me with a view to the Committee being set up in accordance with regulations prescribed by the Food (Defence Plans) Department. It was laid down in the instructions that the Committee should consist of:—

(a) 10 Members, selected so that (i) all classes of consumers in the area are represented and that (ii) at least two are women.

(b) 5 Trade Members.

The 10 following Representatives were asked to serve and all have signified their willingness to do so:—

Councillor F. H. Bate	Child's Hill.
Councillor H. Connell, J.P.	Burnt Oak.
Mrs. M. E. Cunningham	Representing Co-operators.
Alderman S. H. Egan, J.P.	Central Hendon.
Councillor W. A. Hicks	Garden Suburb.
Councillor L. Hirshfield	Golders Green.
Councillor (Mrs.) F. E. Parvin	Park (Hendon).
Alderman F. C. Rice	Mill Hill.
Councillor G. R. Richardson	West Hendon.
Mr. E. O. Robinson, M.A.	Edgware.

The following are the 5 Trade Representatives:—

Mr. S. W. Mitchell	Hendon & District Grocers' Association.
Mr. H. B. Little	Retail Butchers.
Mr. Beech	Co-operative Traders (London Co-operative Society, Ltd.).
Mr. E. E. Canning	Dairy Trades.
Mr. J. T. Seabrook	Greengrocery Trade.

10 Members having agreed to serve, the Food Control Committee was deemed to be duly constituted and it held its first meeting on Saturday, 2nd September, when the following appointments were made:—

Chairman	Alderman S. H. Egan, J.P.
Deputy Chairman	Councillor L. Hirshfield.
Food Executive Officer	Mr. George Hails.
Deputy Food Executive Officer	Mr. A. P. McCourt.

The following is a brief outline of the duties of the Food Control Committee:—

- (a) The registration of consumers and the issue of rationing documents.
- (b) The registration and licensing of retail dealers in foodstuffs.
- (c) The certification of retailers' requirements as directed by the Ministry.
- (d) The transference of registered customers from one retailer to another upon good cause shown.
- (e) The certification of the food requirements of hostels, residential and catering establishments, hotels, and other institutions as directed by the Ministry of Food.
- (f) The inspection of the records of dealings in, and of the prices charged for, controlled commodities.
- (g) The obtaining of such Returns and information as the Ministry may require.

(h) The enforcement of such Orders relating to food control as the Ministry may direct.

The local expenses of Food Control are borne directly by the Food (Defence Plans) Department.

3.—FUEL AND LIGHTING ORDER, 1939:

Under the above Order steps are to be taken to deal with the rationed supplies of coal, gas and electricity to domestic and smaller industrial consumers.

The Order will operate on the basis not of persons but of premises, although it must not be assumed there will be no limitation on supplies to premises of other consumers. The basic principle of the Order is that consumers coming within its scope will be entitled to a proportion only of the coal, gas and electricity consumed by them in a period prior to the introduction of the Order.

The responsibility for the administration of the Order is placed on Local Authorities acting through Local Fuel Overseers. Although Local Fuel Overseers are appointed by the local authorities they are required to comply with any instructions given to them by, or on behalf of, the Secretary for Mines or by the Divisional Coal Officer for the Division in which the district is situate.

An Advisory Committee representative of persons supplying coal, gas or electricity and of any registered Industrial or Provident Society carrying on the business of distributing coal in the area, is required to be appointed and the Local Authority may also make arrangements for the supervision and control of the Local Fuel Overseer and the expenditure incurred by him. The Council indicated some time ago that they desired the Borough Treasurer to undertake the duties of Local Fuel Overseer and acting under my Recess powers I have appointed Mr. George Hails as Local Fuel Overseer with Mr. G. W. M. Smith as Deputy Local Fuel Overseer.

The Association of Retail Coal Merchants, the London Co-operative Society, Ltd., the North Metropolitan Electric Power Supply Company and the North Middlesex Gas Company have been asked to nominate representatives to the advisory Committee. Sir Charles McRea, of Messrs. J. H. Beattie & Co. Ltd., has been nominated on behalf of the Society of Coal Merchants but the names of the persons nominated by other Trade interests have not yet been received.

The Local Authority is required to provide such accommodation and assistance as may be necessary for the performance of the duties of the Fuel Overseer, but the reasonable expenses incurred by a Local Authority will be refunded by the Mines Department.

I have appointed Alderman W. M. Maughan, J.P., and Councillors Windust and Griffiths as a Committee to supervise and control the Local Fuel Overseer and the expenditure incurred by him and to act generally in a consultative capacity.

Coal Rationing becomes effective from 1st October, 1939, and Gas and Electricity Rationing as from the date of consumers next meter reading after the date when the Order comes into force.

4.—AIR RAID PRECAUTIONS RATIONS:

I authorised the use of the Lecture Room at the Central Library for storage of rations as an emergency matter.

5.—LOAN SANCTIONS:

The following Sanctions have been received from the Ministry of Health, and the Borough Treasurer has been authorised to raise loans against such sanctions as and when required:—

Date.	Purpose.	Amount. £	Period. Years.
18/7/39	Edgwarebury Park, Dressing Rooms and Convenience	1,950	30
18/7/39	Penshurst Gardens, Edgware, Extension of culvert	1,250	5
27/7/39	Reconstruction works, Finchley Road	3,000	16
14/8/39	North End Road Improvements	5,600	7
21/8/39	Broadfields Avenue School Site	8,855	60

6.—LOANS:

I authorised the repayment of £100 in respect of mortgage No. 403 (Mrs. H.M.P.S.).

Authority was given for a loan of £10,000 for a period of 5 years certain at 3½ per centum per annum to be taken up from the Trustees of the Newcastle-upon-Tyne branch of the Boiler Makers Iron & Steel Shipbuilders Society.

7.—SUPERANNUATION—REFUND OF CONTRIBUTIONS:

Authority was given for the repayment of superannuation contributions to Mr. J. Henderson (Ref. 716) of the Borough Treasurer's Department amounting to £23 14s. 0d. following his resignation from the service of the Council upon his entry into the Royal Air Force.

Authority was given for the repayment of superannuation contributions to Mr. C. J. Smith (Ref. 629) of the Borough Engineer's Outdoor Staff, amounting to £37 12s. 0d. following upon his resignation from the service of the Council.

8.—INSURANCE FUND:

I gave authority for the Insurance Fund to carry the fire risk in respect of a new building recently erected in Montrose Park for the purpose of a sandbag store at an annual premium of 4/6d. and a cover of £150.

9.—PAY ORDERS:

I have examined and approved the following Pay Orders:—

List No.	£	s.	d.
47/51	203109	14	3
52 (Loans Pool)	75	1	3
53	4907	13	10
54	5430	14	3
55/61	6738	4	4
62	328	16	9
63/67	9584	1	5
68/69	875	14	9
70	1209	9	3
71/74	62643	14	5
75/76	8136	7	0
77/82	14471	10	2
83	1170	1	5
84	4271	5	4
85/90	11554	4	10
91	1279	7	10
92/95	17682	7	2
96 (Loans Pool)	100	0	0
97	11807	6	8

10.—SMALL DWELLINGS ACQUISITION ACTS:

Authority for the necessary vacating receipt was given on the repayment of Mortgage No. 339/R.3902.

11.—HOUSING—STAFF:

Miss Duckering has obtained the degree of B.Sc. (Estate Management) of London University, and I have approved her appointment to the permanent staff as Housing Assistant from the 1st August, 1939, in Grade "D" at a commencing salary of £150 per annum, her next increment to date as from 1st January, 1940. Miss Duckering has passed the usual medical examination.

I approved the continuation of the services of Miss C. R. Brown as Housing Student for the remainder of the initial period of 12 months, she having satisfactorily completed the first three months probationary service.

12.—TRANSPORT—HOUSING REPAIRS:

The Borough Treasurer reported to me that having regard to the present emergency the question of transport in connection with housing repairs might be difficult to cope with in view of the fact that Messrs. Turner's lorries would probably be commandeered. I authorised the Borough Treasurer to obtain prices for a suitable vehicle, and after consulting Councillor Greville on the prices and the details of the vehicles concerned gave authority for the purchase of a 30 cwt. Bedford re-conditioned 1938 truck for the sum of £170. Councillor Gilpin, the Chairman of the Housing Committee, concurs in the action taken. I was informed that hired transport has hitherto frequently amounted to £10 per week.

13.—ALLOTMENT OF HOUSES:

Appln. No.	Name and Address.	Family.	House Allotted.
6710*	Vincent, W. H., 18, Oldberry Road.	H. & W. 7 children.	7, Brookfield Close.
6516	Gammage, G., Kennel Compound, Rhodes Farm, N.W. 7.	H. & W. 2 children.	9, Brookfield Avenue.
6714	Steeple, J. H., 79, Park Road.	H. & W. —	24, Clitterhouse Road.
6265	Rudd, E., 39, Ramsay Road.	H. & W. 3 children.	133, Fryent Grove.
5112	Wiltshire, J., 137, Iverson Road.	H. & W. 3 children.	21, Clitterhouse Road.
5816	Prickett, H. W., 8, Ravenstone Road.	H. & W. 2 children.	31, Goldsmith Avenue.
6730	Baines, W. L., 5, Wingfield Cottages.	H. & W. Brother-in-Law.	133, Clitterhouse Road.
6330	Oliver, J. W., 8, Grange Hill.	H. & W. 3 children.	55, Clitterhouse Crescent.
6698*	Regnier, W. F., 41, Oldberry Road.	H. & W. 6 children.	51, Dole Street.

14.—TRANSFER OF TENANCIES:

Appl. No.	Name.	From.	To.
5574	Windsor, H. G.	51, Dole Street	117, Bittacy Hill.
3666	Smith, E. J.	37, Sturgess Avenue.	32, Sturgess Avenue.
5295*	Hill, H. G.	41, Riverside	37, Sturgess Avenue.

* Denotes overcrowding.

15.—GARDENS COMPETITION:

The judging has been completed in connection with the annual gardens competition and the results on the various estates are as follows:—

Child's Hill Estate:—

1st Prize	Busby, W. H.	31, Garth Road.
2nd Prize	Hobday, F. T.	100, Cloister Road.
3rd Prize	Martin, H. G.	29, Garth Road.
Commended	White, G. E.	12, Garth Road.

Clitterhouse Estate:—

1st Prize	Francis, A. J.	36, Clitterhouse Road.
2nd Prize	Saxby, D.	81, Clitterhouse Road.
3rd Prize	Stokes, G. W.	85, Clitterhouse Road.
Very highly commended	Saxby, M.	52, Clitterhouse Road.
Very highly commended	Hawes, W.	79, Clitterhouse Road.
Very highly commended	Lowe, G.	13, Clitterhouse Crescent.

The Hyde and Kingsbury Road Estates:—

1st Prize	Smith, R. J.	49, Hyde Crescent.
2nd Prize	Mills, H. R.	42, Goldsmith Avenue.
3rd Prize	Boaler, G. W.	21, Hyde Crescent.
Very highly commended	Guntrip, H.	15, Hyde Crescent.
Very highly commended	Aston, A. T.	41, Hyde Crescent.
Highly commended	Simpson, A. E.	17, Hyde Crescent.
Highly commended	Copley, E.	65, Hyde Crescent.
Highly commended	Saunders, W.	113, Goldsmith Avenue.

Reets Farm Estate:—

1st Prize	Miles, F. J.	123, Fryent Grove.
2nd Prize	Mitchener, C. L.	38, Fryent Crescent.
3rd Prize	Brown, E.	60, Fryent Grove.
Very highly commended	Finch, W. E.	45, Fryent Grove.
Highly commended	Hawes, R. P.	121, Fryent Grove.
Highly commended	Day, S. L.	23, Fryent Crescent.

(comparatively new tenant)

Brent Hill Estate:—

1st Prize	Whale, E. T.	21, Sturgess Avenue.
2nd Prize	Denmark, C.	89, Sturgess Avenue.
3rd Prize	Rogers, C. D.	82, Park Road.
			Randall, J.	112, Sturgess Avenue.
Highly commended	Drewell, G. C.	16, Daniel Place.
Highly commended	Fountain, A.	22, Sturgess Avenue.

Bittacy Hill Estate:—

1st Prize	Simmonds, A. J.	147, Bittacy Hill.
2nd Prize	Robinson, J.	30, Sanders Lane.
3rd Prize	Hope, P.	121, Bittacy Hill.
Highly commended	Fisher, J. A.	115, Bittacy Hill.
Highly commended	Francomb, W.	26, Sanders Lane.

Dole Street Estate:—

1st Prize	Deeks, C.	25, Dole Street.
2nd Prize	Rayner, H.	46, Pursley Road.
3rd Prize	Lodge, A.	44, Pursley Road.
Very highly commended	Andrews, E.	11, Dole Street.
Very highly commended	Severn, C.	27, Brookfield Avenue.
Highly commended	Paine, A. E.	1, Dole Street.
Highly commended	Cowland, S.	45, Dole Street.

The Championship Challenge Cup:—

E. T. Whale 21, Sturgess Avenue.

16.—ALLOTMENTS:

Authority was given for notice to quit to be served in respect of plot No. 65, Archfields.

17.—PRIVATE STREET IMPROVEMENTS—MARION ROAD:

I have authorised the signing of an indemnity for the release of certain monies deposited with Barclays Bank Limited in joint names. On the sealing of the indemnity the monies in question amounting to £62 with interest, will be paid to the account of the Corporation.

18.—RATING AND VALUATION:

The Chief Rating and Valuation Officer reported to me that it was desirable to obtain Counsel's Opinion in regard to a decision of the Central Middlesex Assessment Committee as to the assessment of certain "let-out" properties. Counsel's Opinion having been obtained it was decided to lodge an appeal to Quarter Sessions, but in view of the National Emergency I authorised such appeal to be withdrawn.

19.—RECONSTRUCTION OF BRIDGES CARRYING THE LONDON & NORTH EASTERN RAILWAY OVER BITTACY HILL AND FRITH LANE, MILL HILL:

I considered tenders forwarded by the London & North Eastern Railway Company for the reconstruction of the above bridges, and gave authority for the Company to be informed that the Corporation has no objection to them accepting the lowest tender, viz., that of Messrs. Fletcher & Company (Contractors) Ltd. amounting to £27,843 3s. 7d.

20.—BUS STOP SIGNS:

A letter from the London Passenger Transport Board asking permission to erect standard bus stop signs in Golders Green Road at the following points, was submitted to me, and I gave authority for permission to be given, subject to the standard agreement being entered into:—

East bound—at Nos. 16/18.

West bound—on lamp standard No. 1245 at Nos. 11/13.

21.—PUBLIC TELEPHONE KIOSK:

An application from the London Tele-communications Region of the Post Office for permission to erect a public telephone kiosk on the footway of Hartley Avenue, Mill Hill, adjacent to the Cinema was approved, subject to the standard agreement being entered into.

22.—ISOLATION HOSPITAL, HENDON—SURGICAL UNIT:

Tenders received for the above work were submitted to me, and I gave authority for the provisional acceptance of the lowest tender received, viz., that of Messrs. Norman. Wright (Builders) Limited of South Norwood, amounting to £2,889, and for the corporate seal to be affixed to any necessary documents.

I also gave authority for an application to be made to the Minister of Health for a loan sanction, made up as follows:—

	£
Amount of provisionally accepted tender	2,889
Heating and hot water supply	356
Quantity Surveyor's fee	100
Clerk of Works salary	70
Cost of raising loan, etc.	35
Total	<u>£3,450</u>

23.—WATLING PARK:

A letter was received from the Watling Association applying for the use of a third rink on the bowling green in Watling Park, and authority was given for the use by the Association of a third rink, at a pro-rata increase in the present rental of £7 10s. 0d. per rink, plus 1/- per member.

24.—AIR RAID PRECAUTIONS—WARDENS' POSTS:

It was reported to me that tenders had been received for the construction of 94 wardens' posts, and authority was given for the acceptance of the tender of Garsubil Limited amounting to £5,640, and for the necessary work to be put in hand.

25.—EDGWARE SENIOR SCHOOL:

Consideration was given to a schedule of tenders received for the erection of Edgware Senior School. The lowest tender is that of E. S. Moss Limited amounting to £20,500.

Subject to approval of the plans by the Board of Education, authority has been given:—

- (a) for the tender of E. S. Moss Limited amounting to £20,500 to be provisionally accepted and for the Corporate Seal to be affixed to the necessary contract in due course;

(b) for application to be made to the Minister of Health for sanction to the raising of a loan of £22,600, made up as follows:—

Amount of provisionally accepted tender	£	20,500
Furniture and fittings	850
Quantity Surveyor's fees	512
Clerk of Works salary	556
Legal expenses, cost of raising loan, etc.	182
					£22,600

(Loan periods:—

Building—Not exceeding 40 years.

Furniture—Not exceeding 10 years.)

26.—HENDON PLANNING SCHEME NO. 1—APPLICATIONS FOR CONSENTS:

(A). *The Bunting Construction Company, Limited, in respect of the Bittacy House Estate, Mill Hill.*

I considered an application received from The Bunting Construction Company, Limited, for permission to erect 396 flats on the Bittacy House Estate, Mill Hill, and gave authority for the application to be disapproved under the provisions of Clauses 28, 35 and 36, and also under the provisions of the Restriction of Ribbon Development Act of 1935.

(B). *Messrs. Bethell and Swannell in respect of the Manor House Hospital, North End Road, Golders Green.*

An application for permission to instal a petrol pump and tank in the grounds of Manor House Hospital was submitted to me, and authority was given for consents to be issued under Clause 29 of the Scheme, and also under the Restriction of Ribbon Development Act, both consents to contain a restriction limiting the use of the tank and pump for private purposes.

(C). *Mr. H. C. Bently in respect of The Club House Garage, Highwood Hill, Mill Hill.*

I considered an application received from Mr. H. C. Bently for permission to establish a petrol filling station on land near the junction of Highwood Hill and Lawrence Street, Mill Hill, and gave authority for the same to be disapproved under Clause 29 of the Scheme and under the Restriction of Ribbon Development Act.

27.—HENDON PLANNING SCHEME NO. 2—APPLICATION FOR CONSENT:

Mr. Jelinck-Karl in respect of land at the junction of Highfield Road and Golders Green Road, Golders Green.

I gave consideration to an application received for the use of the land at the junction of Highfield Road and Golders Green Road for the purpose of a cinema accommodating 608 people.

I gave authority for the same to be disapproved under Clauses 28, 42 and 43 of the Scheme, and under the Restriction of Ribbon Development Act.

28.—WOOD GRANGE ESTATE, EDGWARE:

It was reported to me that The Neasden Property Company, who are developing an estate at Edgware, desired to make the following alterations in the names of the roads they are laying out, and I gave authority for the application to be approved:—

Fairmead Road to be Fairmead Crescent.

Glenton Avenue to be Harecourt Avenue.

29.—BUILDING APPLICATIONS:

The applications received and the action taken thereon are shown in the appendix to this report.

30.—PETROLEUM STORAGE LICENCES:

Approval was given on an application from Messrs. Bethell & Swannell, on behalf of the Orthopaedic Society Limited, to store 500 gallons of petroleum in an underground tank at Ivy House, North End Road, Golders Green, for private use.

31.—FACTORIES ACT, 1937:

Inspections have been carried out at the following premises and authority given for certificates to be issued as to means of escape in case of fire:—

J. B. Finlay & Co. Ltd., Ludgate Works, Rookery Way, N.W. 9.

London Passenger Transport Board, Golders Green Depot, Finchley Road, N.W. 11.

Johanna Dearlove's Laundry Ltd., Granville Road, N.W. 2.

32.—DEPUTY MEDICAL OFFICER OF HEALTH:

I conferred with the War Emergency Committee on the following recommendation:—

“That the Emergency Committee recommend in the interest of Air Raid Precautions Services that Dr. J. A. Livingstone be appointed Deputy Medical Officer of Health forthwith on a salary scale to be fixed by His Worship the Mayor in consultation with the Chairman of the Public Health and Medical Services Committee and the Medical Officer of Health.”

After full discussion I confirmed the appointment, and in subsequent consultation with the Chairman of the Public Health and Medical Services Committee and the Medical Officer of Health, approved a salary scale commencing at £900 per annum, rising by annual increments of £50 to a maximum of £1,000, plus £100 car allowance per annum, subject to the consent of the Minister of Health to the appointment and the scale of salary. The Minister of Health has notified his approval to the appointment.

33.—ISOLATION HOSPITAL—EMERGENCY ARRANGEMENTS:

Upon urgent representations from the Ministry of Health and after consultation with the Medical Officer of Health and Borough Surveyor, I approved the following works for the adaptation of the above Hospital as a Casualty Clearing Hospital:—

- (i) The conversion of Ward Kitchen (Block No. 6) into an additional operating theatre and other consequential works. Estimated cost £37 2s. 6d.
- (ii) Additional entrance to Hospital grounds from Kingsbury Road. Estimated cost £25 0s. 0d.
- (iii) The conversion of Ward Kitchen (Block No. 5) to permit of the installation of emergency X-Ray apparatus, and other consequential works. Estimated cost £50 0s. 0d.

The reasonable and necessary costs of these works, up to the estimated figures, will rank for a 70 per cent. grant from the Ministry.

34.—DEFECTIVE CHILDREN:

On the reports of the Medical Officer of Health the following action has been taken:—

S.J., Chorea
Burnt Oak.
6/3/31.

Admission to Queen Mary's Hospital, Carshalton, for a period of six weeks and case to be reviewed at the expiration of that period with a view to extension if necessary.

n to the raising

£
20,500
850
512
556
182
£22,600

MENTS:

on Company,
Mill Hill, and
ns of Clauses
Development

e grounds of
onsents to be
bon Develop-
nk and pump

ermission to
nd Lawrence
r Clause 29

t the junc-
accommo-

and 43 of

veloping an
the roads

A.S., N.W. 2. 6/4/34.	Asthma and Dermatitis	Admission to a residential Open Air School for a period of six months and case to be reviewed at the expiration of that period with a view to extension if necessary.
M.B., Burnt Oak. 8/1/27.	General Debility	4 weeks' convalescence.
R.F., N.W. 7. 15/6/28.	Mentally Defective (Feeble-minded) Mental age 7 8/12 Actual age 11 Mental ratio 68	Admission to a residential Catholic School for educable feeble-minded children.
M.B., N.W. 2. 13/5/26.	General Debility	4 weeks' convalescence.
D.W., Burnt Oak. 2/2/26.	Mentally Defective (Feeble-minded) Mental age 7 Actual age 13 Mental ratio 53	Admission to the Special Day School for Educable Mentally Defective Children, Oak Lodge, Finchley.
A.C., Burnt Oak. 3/4/29.	General Debility	2 months' convalescence.
F.B., Burnt Oak. 24/12/32.	Anæmia	1 month's convalescence.
P.Y., Burnt Oak. 12/5/27.	Nervous debility	4 weeks' convalescence at a Roman Catholic Convalescent Home.
A.W., Burnt Oak. 10/11/26.	General Debility	1 month's convalescence at a Roman Catholic Convalescent Home.
H.F., N.W. 4. 11/5/27.	Sub-acute Rheumatism	4 weeks' convalescence at a Roman Catholic Convalescent Home.
L.S., N.W. 4. 25/12/31.	Malnutrition and General Debility	1 month's convalescence.
M.D., N.W. 4. 16/6/29.	General Debility following treatment for enlarged tonsils and adenitis	4 weeks' convalescence.
G.J., N.W. 9. 14/10/26.	Debility and history of Epilepsy	1 month's convalescence.
M.P., Burnt Oak. 29/8/28.	Rheumatic endocarditis	3 months' convalescence at a Hospital School and the case reviewed at the expiration of that period with a view to extension if necessary.

R.T., Burnt Oak. 12/1/31.	Debility	2 months' convalescence.
D.P., Burnt Oak. 18/11/25.	Mentally Defective (Feeble-minded)	Admission to the Special Day School for Educable Mentally Defective Children, Oak Lodge, Finchley.
D.W., Burnt Oak. 25/7/27.	Mentally Defective (Feeble-minded)	Admission to the Special Day School for Educable Mentally Defective Children, Oak Lodge, Finchley.
I.J., N.W. 2. 22/10/28.	General Debility	2 months' convalescence.
B.S., Burnt Oak. 27/3/26.	Rheumatic Condition of Heart	3 months' convalescence at a Heart Home.
P.L., Burnt Oak. 14/12/27.	Debility	1 month's convalescence at a Roman Catholic Home.
F.D., Burnt Oak. 29/7/31.	Mentally Defective (Feeble-minded)	Admission to the Special Day School for Educable Mentally Defective Children, Oak Lodge, Finchley.
J.P., Burnt Oak. 7/2/34.	Debility	2 weeks' convalescence (with mother and sister Shirley).

35.—MATERNITY AND CHILD WELFARE ACT, 1918:

M.D., N.W. 2.	General Debility	1 month's convalescence.
I.J., N.W. 2.	Debility following Tonsillectomy	1 month's convalescence.
J.B., N.W. 9. 14/3/38.	Debility with Chronic Bronchitis	1 month's convalescence.
Mrs. M., Burnt Oak.	General Debility	2 weeks' convalescence with baby 11 months (Maureen).
Mrs. P. and daughter. 17/4/37. Burnt Oak.	Menopause Debility	2 weeks' convalescence. 2 weeks' convalescence.
B.H., 3/8/37.	Debility following Tonsillitis	4 weeks' convalescence.
P.H., 13/9/38. Burnt Oak.	Debility following Tonsillitis	4 weeks' convalescence.

36.—MIDWIVES ACT, 1936:

Case of Mrs. Martha Maria Jackman, 38, Cricklewood Lane, N.W. 2.

The above-named Midwife has surrendered her Certificate of the Central Midwives Board and authority has been given for the case to be dealt with in accordance with Section 5 (1) of the Midwives Act, 1936.

37.—MIDWIFERY LECTURES:

A letter has been received from the Clerk of the London County Council intimating that the County Council is prepared to continue during the financial year 1939/40 the arrangements whereby courses of lectures and demonstrations in ante-natal and post-natal work, and in general midwifery, are open to Midwives residing or practising within the area specified.

The proposed charges for admission will be sixpence for each lecture and two shillings for each course of demonstrations, any deficit on the courses being shared by the authorities concerned on the basis of user.

I agreed that the London County Council be informed that the Town Council is again desirous of participating in the arrangements.

38.—CHILD LIFE PROTECTION:

Applications have been received from the under-mentioned persons for permission to undertake for reward the nursing and maintenance of children under the age of nine years apart from their parents.

Approval was given to the number of Foster Children to be kept to be fixed at one in all cases, except No. 280 in which case the number shall not exceed two.

Name and Address of Foster Mother.	Accommodation.	Number of Occupiers.
Case No. 276	2 living and 3 sleeping rooms	2 adults 2 children, and 1 foster child.
Case No. 277	2 living and 3 sleeping rooms	3 adults and 1 foster child.
Case No. 278	2 living and 2 sleeping rooms	2 adults and 2 children.
Case No. 279	2 living and 2 sleeping rooms	2 adults and 1 child.
Case No. 280	2 living and 2 sleeping rooms	2 adults and 2 children.

39.—CHILD WELFARE—EMERGENCY SESSIONS:

In view of the fact that the Health Centre at the rear of the Public Library, The Burroughs, Hendon, N.W. 4, and the Health Centre, Hartley Avenue, Mill Hill, N.W. 7, are being used as First Aid Posts, arrangements have been made for the maternity and child welfare sessions to be transferred to the Methodist Sunday School, The Burroughs, and the Methodist Church Hall, Goodwyn Avenue, Mill Hill.

It will be necessary to use the former Church Hall for eight half day sessions per week and the latter for three half day sessions per week, and approval has been given to the payment of 10/6d. per half day session.

The Town Clerk will take such action as may be necessary for the execution of agreements, to which authority has been given for the corporate seal to be affixed.

40.—ISOLATION HOSPITAL—CONSULTING SURGEON:

Owing to Mr. Trevor Jones being absent on annual holiday from 19th August until 3rd September, I agreed that Mr. Gilbert Howells be engaged to act as deputy during this period and that he be paid at the rate of ten guineas per operation and five guineas per consultation.

41.—STAFF:

- (i) I authorised the Town Clerk to engage an additional Typist in a temporary capacity at salary according to scale.
- (ii) In order to relieve the congestion of the work in the Public Health Department I authorised the Medical Officer of Health to engage a temporary Shorthand-Typist at a salary of £75 per annum.
- (iii) Consequent on the resignation of Mr. J. Henderson from the Borough Treasurer's Department authority was given to fill the vacancy.
- (iv) I received the resignation of Miss P. K. Bartram, Junior Assistant at the Central Library, on her appointment to a similar position in the East Ham Public Library. Her services were terminated on Saturday, 12th August, and authority was given for the engagement of a temporary assistant from the 14th August.

The vacant position was advertised and 37 applications were received. Owing to the outbreak of war the selection and interviewing of candidates was deferred.

42.—REQUISITIONS:

The following requisitions were submitted and **approved**:—

	£	s.	d.
Town Clerk's Department	6	15	6
Town Clerk's Department	56	0	0
General Stationery	220	19	7
Borough Surveyor's Department	4,412	4	8
Public Libraries	141	3	8
School Medical Services	46	15	0
Public Health Department	26	9	10
Maternity and Child Welfare	52	9	6

43.—SEALING OF DOCUMENTS:

The Corporate Seal has been affixed to the following:—

Contract	Siemens and General Electric Railway Signal Company Limited and the Corporation re installation of Traffic Signals—Finchley Road, Golders Green Road and North End Road.
Agreement	The Corporation and Grand Union Canal Company for laying of a sewer in North Circular Road, Hendon.
Counterpart Agreement	The Corporation and the Anglo American Oil Co. Ltd. for supply of Fuel Oil.
Agreement	The Corporation and the Clitterhouse Community Association—for the use of a dressing room in the Clitterhouse Playing Field.

44.—BILLETING:

Under the powers vested in me by the Minister of Health, I have appointed the Director of Education as the Chief Billeting Officer and a number of his officers as Assistant Billeting Officers.

It was also necessary to constitute a tribunal to hear appeals against billeting notices, and under the same authority I appointed Alderman A. J. Reynolds, J.P. (Chairman), Councillors (Mrs.) F. E. Parvin and C. F. Windust.

45.—GENERALLY:

I have dealt with other matters of a routine character in connection with the Borough Treasurer's Department.

HERBERT G. POTTER,

Mayor.

15th September, 1939.

APPENDIX.
BUILDING APPLICATIONS.

(A) The following applications were approved:—

Appln. No.	Description and Situation.	Public Health Act, 1936.	Town Planning.	Restriction of Ribbon Development Act, 1935.
A.755Na	Garage, 19, Worcester Crescent, N.W. 7. Applicant—G. Wimpey & Co. Ltd. Owner and	Approved	—	—
A.8152	Extension to porch, "Brookside," Dollis Road, Mill Mill. Owner—E. W. Densham. Applicant—R. Densham & Sons	Approved	—	Approved.
A.8154	Amended plan of garage, 149, Station Road, Edgware. Owner and Applicant—L. Raymond	Approved	Consent given under Clause 42 (ii)	—
A.8175	Conversion of 107, Sunny Gardens Road, Hendon, into two flats. Owner and Applicant—J. S. Giles	Approved	Condition:— That the proportion of site which may be covered by buildings shall not exceed 80 per cent.	—
A.8177	Addition, 59, New Way Road, N.W. 9. Owner and Applicant—W. D. Davies	Approved	Consent given under Clauses 35 and 36	—
A.8178	Air raid shelter, 13, Hocroft Road, N.W. 2. Owner—N. Frizzle. Applicant—F. Troy & Co.	Approved	—	—
A.8183	Alterations, 37, Woodville Road, N.W. 11. Owner and Applicant—D. Myers	Approved	—	—
A.8184	Air raid shelter, 35, Sydney Grove, Hendon. Owner—Mr. Mashford. Applicant—J. Webb & Son (Builders) Ltd.	Approved	—	—
A.8185	Addition, 1, Sylvan Avenue, N.W. 7. Owner and Applicant—Major B. B. Wills	Approved	—	—
A.8189	Air raid shelter, south side, Colindeep Lane, N.W. 9. Owner—Davies Tyre Co. Ltd. Applicant—S. C. Tee & Gale	Approved	—	Approved.

Appl. No.	Description and Situation.	Public Health Act, 1936.	Town Planning.	Restriction of Ribbon Development Act, 1935.
A.8192	Offices, east side, Rookery Way, N.W. 9. Owner—Spurling Motor Bodies Ltd. Applicant—Dudley G. Marsh	Approved	—	—
A.8194	Garage, 29, Worcester Crescent, N.W. 7. Owner and Applicant—G. Wimpey & Co. Ltd.	Approved	—	—
A.8198	Air raid shelter, 51, West Heath Road, N.W. 3. Owner—E. M. Collins. Applicant—E. Westlake	Approved	—	—
A.8199	Garage, 12, Selvaige Lane, Mill Hill. Owner and Applicant—J. W. Hepburn	Approved	—	Approved.
A.8200	Alterations and addition, 3, Thornfield Parade, Holders Hill Road, N.W. 7. Owner—E. Davis. Applicant—B. Ewart Dixon	Approved	Consent given under Clause 28	Approved.
A.8205	Air raid shelter, 10, West Heath Avenue, N.W. 11. Owner—B. Collier. Applicant—F. Troy & Co.	Approved	—	—
A.8207	Air raid shelter, 48, Hampstead Way, N.W. 11. Owner—Dr. Mathew. Applicant—F. Troy & Co.	Approved	—	—
A.8208	Air raid shelter, 16, Reynolds Close, N.W. 11. Owner—Dr. Macrae. Applicant—F. Troy & Co.	Approved	—	—
A.8209	Alterations, 83 and 85, Church Road, Hendon. Owner—V. Stummel. Applicant—T. F. Young	Approved	—	—
A.8210	House and garage, north-west side, Hale Lane, Edgware. Owner and Applicant—H. J. Hook	Approved	—	—
A.8212	Air raid shelter, 45, Rowsley Avenue, Hendon. Owner—F. Grimm. Applicant—S. Blow Ltd.	Approved	—	—
A.8214	Alterations, 294, Hale Lane, Edgware. Owner—Betty's. Applicant—Passmore Bros.	Approved	Consent given under Clauses 35 and 36	—
A.8217	Air raid shelter, 6, Heathgate, N.W. 11. Owner—A. Hebbison. Applicant—W. M. Glendinning	Approved	—	—
A.8219	Addition, 81, Hendon Way, N.W. 2. Owner—Mrs. Morris. Applicant—Oram (Builders) Ltd.	Approved	—	—

Appln. No.	Description and Situation.	Public Health Act, 1936.	Town Planning.	Restriction of Ribbon Development Act, 1935.
A.8220	Air raid shelter, 587, Watford Way, N.W. 7. Owner— I. M. Edelman. Applicant—F. G. Protheroe Ltd.	Approved	—	—
A.8228	Garage, 10, Sefton Avenue, Mill Hill. Owner and Applicant—A. G. Hill	Approved	—	—
A.8010w	Block plan of bungalow, 3, Hartland Close, Edgware. Owner and Applicant—J. Laing & Son Ltd.	Approved	—	—
A.8063h	Garage, plot 36, Fairmead Crescent, Edgware. Owner and Applicant—Neusden Property Co.	Approved	—	—
A.8196	Garage, 2, Sinclair Grove, N.W. 11. Owner—R. Whipp. Applicant—F. Dymock Ltd.	Approved	—	Approved.
A.8197	8 air raid shelters, first aid and cleansing station, north- east side, Bitlacy Hill, Mill Hill. Owner—United Kingdom Optical Co. Ltd. Applicant—H. Wright and Tidmarsh	Approved	—	—
A.8213	Addition, 290, Watford Way, N.W. 4. Owner and Applicant—G. E. Merkel	Approved	—	—
A.8223	Extension to garage, 59, Brampton Grove, Hendon. Owner—E. Newlands. Applicant—W. Richards and Son (Hendon) Ltd.	Approved	Consent given under Clause 43 (3) Condition:— That the east wall of the ex- tension may be erected up to the owner's east boundary	—
A.8227	Air raid shelter, Goods Yard, Station Road, Hendon. Owner and Applicant—Rickett, Cockerell & Co. Ltd.	Approved	—	—
A.8063	Air raid shelter, 20, Wildwood Road, N.W. 11. Owner and Applicant—F. R. Freeman	Approved	—	—
A.8193	Offices and store, south side, Forumside, Edgware. Owner—A. E. Spurrer. Applicant—A. H. W. Tod- man & Son	Approved	Consent given under Clause 43 (3) Condition:— That the north-east wall of the building may be erected up to the owner's north- east boundary	—

Condition:—
That the north-east wall of
the building may be erected
up to the owner's north-
east boundary.

Appl. No.	Description and Situation.	Public Health Act, 1936.	Town Planning.	Restriction of Ribbon Development Act, 1935.
A.8236	24 bungalows, plots 1-24, Dole Street, Mill Hill. Owner and Applicant—R. Malcolms Ltd.	Approved	—	—
A.7954b	Amended plan of alterations, 117, Hampstead Way, N.W. 11. Applicant—J. C. S. Soutar	Approved	—	—
A.8137	Factory extension, north-east side, The Hyde, N.W. 9. Owner—Duple Bodies & Motors Ltd. Applicant—Dudley G. Marsh	Approved	Consent given under Clause 6	Approved.
A.8138	Offices over existing motor showroom, north-east side, The Hyde, N.W. 9. Owner—Spurling Motor Bodies Ltd. Applicant—Dudley G. Marsh	Approved	Consent given under Clause 6	Approved.
A.8163a	Amended drainage plan, 2-8, Bedford Road, Mill Hill. Owner and Applicant—G. Wimpey & Co. Ltd.	Approved	—	—
A.8172	Factory, north-east side, The Hyde, N.W. 9. Owner—Witton-James Ltd. Applicant—C. Tavener & Son Ltd.	Approved	—	—
A.8180	Conversion into two flats, 5, St. John's Road, N.W. 11. Owner—Mrs. A. Mautner. Applicant—S. A. Pully	Approved	Consent given under Clauses 28, 35 and 36	—
A.8181	Conversion into two flats, 7, St. John's Road, N.W. 11. Owner—Mrs. S. O. Smith. Applicant—S. A. Pully	Approved	Consent given under Clauses 28, 35 and 36	—
A.8201	Bungalow, south side, Bittacy Rise, Mill Hill. Owner and Applicant—Lovesay & Son Ltd.	Approved	Consent given under Clause 43 (3)	—
			Condition:— That the distance between the east corner of the bungalow and the owner's east boundary shall not be less than two feet six inches	
A.8231	Garage and air raid shelter, 79, Station Road, Hendon. Owner and Applicant—A. W. Brittain	Approved	—	Approved.
A.8232	Verandah, 16, Fairfield Avenue, Edgware. Owner and Applicant—J. England	Approved	—	—

Appln. No.	Description and Situation.	Public Health Act, 1936.	Town Planning.	Restriction of Ribbon Development Act, 1935.
A.8233	Alteration, 131, Fairfield Crescent, Edgware. Owner and Applicant—H. Leach	Approved	—	—
A.8234	Addition, 7, Mendway, N.W. 11. Owner—E. A. Howard. Applicant—J. C. S. Soutar	Approved	—	—
A.8235	Alterations, 58, West Heath Drive, N.W. 11. Owner—F. Levy. Applicant—Downton & Hersch	Approved	—	—
A.8238	Air raid shelter, 51, Parson Street, Hendon. Owner—H. Willis. Applicant—James Gibb (Hampstead) Ltd.	Approved	—	Approved.
A.8239	Addition, 599, Watford Way, N.W. 7. Owner and Applicant—L. Rowlandson	Approved	—	—
A.8240	Air raid shelter, "Oak Lodge," West Heath Road, N.W. 11. Owner—A. Cohen. Applicant—Juretzki and Bramwell	Approved	—	Approved.
A.8241	Alteration to front door entrance, 59, The Drive, Edgware. Owner and Applicant—L. Lewis	Approved	—	—
A.8242	Dormer window, 4, Willifield Way, N.W. 11. Owner—J. Garside. Applicant—John C. S. Soutar	Approved	—	—
A.8244	Garage, 64, Worcester Crescent, N.W. 7. Owner and Applicant—George Wimpey & Co. Ltd.	Approved	—	—
A.8243	Alteration, 3, Watling Avenue, Burnt Oak, Edgware. Owner—London County Council. Applicant—A. H. W. Todman & Son	Approved	Consent given under Clause 42 (ii) Condition:— That the proportion of site which may be covered by buildings shall not exceed ninety-one per cent.	—
A.8246	Garage, 32, Broadhurst Avenue, Edgware. Owner—J. W. H. Holmes. Applicant—W. Rudd	Approved	—	—
A.8248	Outside W.C., 74, Cranbourne Gardens, Golders Green. Owner—G. L. Godden. Applicant—G. Barber and Sons	Approved	—	—

Appn. No.	Description and Situation.	Public Health Act, 1936.	Town Planning.	Restriction of Ribbon Development Act, 1935.
A.8248	A. W. H. Holmes. Applicant—W. Rudd Outside W.C., 74, Cranbourne Gardens, Golders Green. Owner—G. L. Godden. Applicant—G. Barber and Sons	Approved		
A.8249	Paint shop, east side, Rookery Way, N.W.9. Owner—Sparring Motor Bodies Ltd. Applicant—Dudley G. Marsh	Approved	Consent given under Clause 43 (3) Condition:— That the north wall of the building may be erected up to the owner's north boundary	
A.8251	House and garage, plot 4, Tenterden Gardens, Hendon. Owner—H. K. Harrison. Applicant—Bernard Engel	Approved		
A.8252	Garage, 73, Deans Way, Edgware. Owner and Applicant—Miss M. Clover	Approved		
A.8257	32 houses, 1-27 and 2-36, Raunilles Road, Mill Hill. Owner and Applicant—G. Wimpey & Co. Ltd.	Approved		
A.8261	Sub-station, east side, Stream Lane, Edgware. Owner and Applicant—The Northmet Power Co.	Approved	Consent given under Clause 28	
A.8262	Air raid shelter, 54, Wykeham Road, Hendon. Owner—D. Yager. Applicant—A. J. Willson & Sons	Approved		
A.8266	Conversion of 7, Hobbabrook Drive, Hendon, into two flats. Owner—A. Taat & Son. Applicant—B. Ewart Dixon	Approved	Consent given under Clauses 35 and 36	
A.8169	Garage, 27, Holders Hill Crescent, Hendon. Owner and Applicant—J. W. Massey	Approved		
A.8262	Garage, 231, Hale Drive, Mill Hill. Owner and Applicant—C. H. White	Approved	Consent given under Clause 6 Condition:— That Consent No. 217 is hereby cancelled	Approved. Conditions:— (1) That a crossing shall be constructed over the public footpath of Hale Drive; the work to be carried out by the Corporation after a deposit has been paid by the applicant to cover the estimated cost. (2) That Consent No. 400 is hereby cancelled.

Appl. No.	Description and Situation.	Public Health Act, 1936.	Town Planning.	Restriction of Ribbon Development Act, 1935.
A.8206	Garage, 157, Chancetonbury Way, N. 12. Owner and Applicant—A. J. Holt	Approved	—	—
A.8211	Garage, plot 44, Fairmead Crescent, Edgware. Owner and Applicant—H. A. Plumstead	Approved	—	—
A.8222	Garage, 111, Cissbury Ring South, N. 12. Owner and Applicant—Mrs. C. Barnett	Approved	—	—
A.8229	Garage, 62, The Ridgeway, N.W. 11. Owner and Applicant—Mrs. A. J. Coish	Approved	—	—
A.8255	Garage, plot 199, Keilworth Road, Edgware. Owner and Applicant—E. Eldridge	Approved	—	—
A.8260	Garage, 47, Chancetonbury Way, N. 12. Owner and Applicant—R. H. Hills	Approved	—	—

(B) The following applications were not in order:—

A.8215	Trade garage, including showrooms and service station, northeast site, Halegrove Gardens, N.W. 7. Owner—J. Fleaming. Applicant—W. A. Hunt	Disapproved (Byelaws Nos. 35, 118, 143 and 145)	Consent refused under Clauses 28, 30 and 43	Disapproved.
A.8218	Garage, The Brown Cottage, Ranauff Road, N.W. 2. Owner—H. Lawson. Applicant—Downton & Horsch	Disapproved (Public Health (Buildings in Streets) Act, 1888)	—	—
A.8263	Garage extension, 87, Platts Lane, N.W. 3. Owner—M. Koerber. Applicant—A. F. Hunt	Disapproved (Byelaws Nos. 21, 22, 97, 143 and 145)	Consent refused under Clause 42 (ii)	—

(C) The following applications for portable buildings were approved for a period expiring on the 31st March, 1942:—

A.8179	Garage, 75, Oakhampton Road, N.W. 7. Owner and Applicant—W. A. Rivers	Approved	—	—
A.8182	Addition to garage, 18, Sinclair Grove, Golders Green. Owner and Applicant—G. K. Turnbull	Approved	—	—
A.8186	Conservatory, 8, Ashley Walk, Hendon. Owner and Applicant—E. W. Warwick	Approved	—	—

A.S182 Addition to garage, 18, Sinclair Grove, Golders Green. Owner and Applicant—G. K. Turnbull
 Approved

A.S186 Conservatory, 8, Ashley Walk, Hendon. Owner and Applicant—E. W. Warwick
 Approved

Appl. No.	Description and Situation.	Public Health Act, 1936.	Town Planning.	Restriction of Ribbon Development Act, 1935.
A.S190	Garage, 36, Foscoote Road, Hendon. Owner—Mrs. Hart. Applicant—I. Hart	Approved	—	—
A.S195	Garage, 97, Cissbury Ring South, N. 12. Owner and Applicant—L. H. Brown	Approved	—	—
A.S203	Garage, 80, Banns Lane, Mill Hill. Owner and Applicant—H. P. Penny	Approved	—	—
A.S216	Garage, 79, Renters Avenue, Hendon. Owner—Mr. Lowenthal. Applicant—F. W. Escott	Approved	—	—
A.S221	Garage, 13, Holders Hill Avenue, N.W. 4. Owner and Applicant—Mrs. B. F. Brennan	Approved	—	—
A.S225	Garage, 7, Laneside, Edgware. Owner—A. H. Barton. Applicant—C. G. Barber	Approved	—	Approved.
A.S270	Dressing room accommodation, east side, Edgwarebury Lane, Edgware. Owner and Applicant—King's Cross Goods Depot Sports Club	Approved	—	—

Item 25—Edgware Senior School.

In reply to Councillor Curton, who enquired whether in view of the state of war the tenders referred to in the above-mentioned item would stand, the Chairman of the Education Committee (Alderman Copestake) stated that the matter would be considered at the meeting of the Education Committee on the 19th instant, and he asked Councillor Curton to raise the question at such meeting.

ADOPTION OF REPORT: Moved by Alderman Copestake, seconded by Councillor Scott, and

361.—RESOLVED—**That the foregoing report be approved and adopted.**

TRANSACTION OF LOCAL GOVERNMENT BUSINESS:

On consideration of Item 5 of the Agenda—to take such action as may be necessary for the transaction of local government business for the period to 9th November next—it was moved by Councillor Shakespeare, seconded by Councillor Naar:—

THAT all Committee work be undertaken by the Finance and General Purposes Committee who shall submit reports to the Council monthly.

Discussion ensued, and on the suggestion of the Mayor it was **agreed** that after consideration of the Report of the Emergency Committee the Council should stand adjourned for half-an-hour to enable the Members to consider the matter.

Further consideration of the motion was accordingly deferred.

REPORT OF EMERGENCY COMMITTEE:

The following Report was submitted:—

**REPORT OF EMERGENCY COMMITTEE
to the MEETING of the BOROUGH COUNCIL.**

18th September, 1939.

To the Mayor, Aldermen and Councillors
of the Borough of Hendon.

Ladies and Gentlemen,

Introduction.

The Committee was appointed by the Council on the 17th April last by resolution in the following terms:—

“That the Council appoint an Emergency Committee consisting of the Chairman of the Committee (Councillor E. Arter), Councillor A. W. Curton and Councillor C. Pinkney, and that such Committee be vested with the widest possible powers to act on behalf of the Council in the event of a state of emergency arising.”

We became operative as from the 31st August on the receipt of the appropriate instruction from the Headquarters of the London Civil Defence Region.

Our first meeting was held on the 1st instant, and since that date we have met daily as a Committee, but in point of fact one or more of us have been available or in attendance at the Town Hall or Air Raid Precautions Department continuously since that date. We have frequently called into consultation Councillor A. A. Naar, M.B.E., Chairman of the Works and Fire Brigade Committee, in an advisory capacity to keep closely in touch with the Auxiliary Fire Service, and the Committee have also had the benefit and advice of His Worship the Mayor at several meetings.

The Council are aware that prior to our operations the Air Raid Precautions Services were under the purview of the Special (A.R.P.) Sub-Committee whilst the auxiliary fire service continued in the control of the Works and Fire Brigade Committee. The activities of the Sub-Committee and the Works and Fire Brigade Committee under both schemes (general and fire fighting) necessarily became vested in the Emergency Committee and for convenience any action taken (since reports were last submitted to the Council) in the development of the Civil Defence Services has been merged into the following report.

1.—COMMUNICATION SERVICES—CONTROL AND REPORT CENTRES—WARDENS, ETC.:

(i). *War Establishments and present strength.*

The War Establishments of the Communications Service (Report Centre Staffs and Messengers) is at full strength but the Air Raid Wardens' Organisation continues to show a deficiency, although the existing personnel is sufficient for efficient working.

(ii). *Control and Report Centres.*

At present the organisation of the Control and Report Centres is based on the short term policy, viz.:—

Control Centre and Main Report Centre at the Technical Institute, Hendon.
Sub-Report Centre at the Swimming Baths, Mill Hill.

The Report Centres of public utility companies are co-ordinated with the official Report Centres.

(iii). *Messengers.*

The Messengers are now properly organised and allocated. An Officer-in-Charge has been appointed.

(iv). *Air Raid Wardens' Organisation.*

The Service is now completely re-organised and comprises 13 Districts, 94 Post Areas and 292 Sectors. The erection of 94 new permanent Posts approved by the Home Office is proceeding and pending the erection of these Posts 94 emergency Posts are now in use.

A contract was let with Messrs. Garsubil Limited for the erection of 94 Wardens' Posts and substantial progress is now being made under this contract.

2.—TRAINING:

Training has been pushed ahead and the standard raised. Anti-gas examinations are now only conducted by C.A.G.S. or A.R.P.S. Instructors and the examination is in two parts, oral and written.

Instruction in regard to organisation has been given to all firms and training arranged for employees.

3.—MOBILISATION:

A scheme for the mobilisation of the personnel of all the Services was prepared before any emergency arose and was put into operation immediately instructions were received from the Home Office to mobilise. The personnel was mobilised in two batches and on each occasion was carried out rapidly and without a hitch.

4.—CIVILIAN DEATHS DUE TO WAR OPERATIONS:

A complete scheme for dealing with civilian deaths due to war operations has been prepared and is at present before the Minister of Health for approval. In the meantime adequate arrangements exist in the event of immediate operations under the scheme being necessary.

5.—GROUND DETECTORS AND DETECTOR SPRAYS:

Ground Detectors and Detector Sprays are in the course of being prepared and will be erected as soon as possible on lamp posts. The Postmaster General has also consented to the use of the tops of post office pillar boxes.

6.—CASUALTY SERVICES:

(i). *Isolation Hospital.*

The Isolation Hospital, which is being used as a Ministry of Health Casualty Clearing Hospital, is in an advanced stage of preparation and could function at any time.

A large amount of work has been necessary at this Hospital to comply with the requirements of the Ministry of Health and also of the Surgeon-in-Charge, and the Committee desire to compliment the responsible officers for the manner in which the adaptations have been carried out.

(ii). *First Aid Posts.*

The following first aid posts are staffed, equipped and ready to function:—

Central Hendon Clinic.
West Hendon Clinic.
Hartley Avenue Clinic.
Mansion, Golders Hill Park.
Redhill County Hospital.
Colindale (L.C.C.) Hospital.

Certain works of adaptation are necessary at Colindale (L.C.C.) Hospital but the work is proceeding.

(iii). *Ambulance and First Aid Party Depots.*

A Special Sub-Committee invited Councillor A. W. Greville to accept the appointment of Superintendent for the organisation of the Ambulance Service, and since this appointment was made much hard work has been carried out for which the Emergency Committee record their deep appreciation.

Accommodation has been provided for ambulances and First Aid Parties at seven depôts and in an emergency the Casualty Services will have the use of ambulances at the Isolation Hospital and Fire Stations.

The Committee are very concerned about the fleet of ambulances available and the following minute has been forwarded to the Scheme Making Authority:—

Councillor A. W. Greville (Ambulance Officer) submitted through the Town Clerk details as to the present strength of the fleet of ambulances and as to their mechanical condition. The Committee are extremely concerned with the report from which it is gathered that the vehicles are in a most unreliable condition and in many cases entirely unsuitable. Attempts have been made to make the existing available vans reasonably serviceable but the proposal as to springs (3/9/39—3) had been found impracticable—costs involved would very probably exceed the value of the vehicles in most cases. There is at present a staff of seven mechanics continuously engaged in keeping the vehicles in a running state but considerable difficulties are experienced and the costs of these services must eventually assume a figure out of all proportion to the doubtful result which might be attained, in addition heavy maintenance costs are likely to continue.

On the 6th instant, the Committee authorised the Ambulance Officer to purchase a second-hand car at a cost not exceeding £30. The vehicle was actually purchased for £29 and its cost with adaptation is not expected to exceed £55, which will provide a comfortable ambulance for four stretcher cases.

It is understood that similar vehicles are available, and the Committee are of the opinion that steps should be taken to provide a fleet of 35 ambulances which will give reliable and efficient service with a degree of comfort.

That representations be made to the Middlesex County Council for immediate consent to an estimated expenditure not exceeding £2,500 on the purchase and adaptation of vehicles as ambulances.

There is a shortage of stretcher party personnel but the deficiency is being met by further recruitment and suitable personnel will be allocated. The existing personnel is, however, sufficient to man the present ambulances.

7.—WOODSIDE PARK—CASUALTY SERVICES:

At the meeting of the Special Sub-Committee on the 30th August it was reported that directions had been given for the casualty services in respect of Woodside Park to be transferred from Finchley to Hendon, and that the necessary adjustments and arrangements were well in hand.

8.—DEPUTY MEDICAL OFFICER OF HEALTH:

The Committee at their meetings held on the 2nd and 3rd instant had the above matter under consideration and deemed it expedient to make the following decision:—

That the Emergency Committee recommend in the interest of air raid precaution services that Dr. J. L. Livingstone be appointed Deputy Medical Officer of Health forthwith on a salary scale to be fixed by His Worship the Mayor in consultation with the Chairman of the Public Health and Medical Services Committee and the Medical Officer of Health.

The matter was the subject of a conference with His Worship the Mayor who confirmed the appointment under recess powers. (See Mayor's Recess Report.)

9.—ASSISTANT MEDICAL OFFICER OF HEALTH:

The Committee have been concerned with a question of adequate staffing of the Control Centre, and in order to provide the necessary medical personnel on call and to augment the staff of the air raid precautions services generally in relation to casualty services, the Committee came to the conclusion that the part-time Medical Assistant Officer for which approval was given in May last, should be replaced by a temporary full-time Assistant.

The following decision in the matter was accordingly given:—

That a temporary full-time Assistant Medical Officer of Health be appointed at a salary of £600 rising by annual increments of £25 to £750, and that the Medical Officer of Health be authorised to nominate a candidate for appointment after consultation with the British Medical Association. (The usual car allowance to be made to the Assistant Medical Officer appointed.)

The Committee understand that it has been found desirable to advertise the appointment, which it is hoped to make at an early date.

10.—TRENCHES:

The trenches which have been constructed under the first sanction from the Home Office and which accommodate 3,750 people are all completed with the exception of those at the junction of Milespit Hill and Wise Lane.

The trenches in Basing Hill and Mill Hill Parks are not complete, but are usable in case of emergency.

With regard to the construction of additional trenches (second sanction) although work on this contract was commenced on the 31st August last progress has been very slow. This is due to the fact that directly the contract was started the Government requisitioned all the mechanical diggers in the London area and set them to work for excavating material for filling sandbags. Excavators are still in use for this purpose and are not likely to be released for some weeks. The Borough Surveyor obtained one excavator for the contractors with the assistance of the Government department dealing with the matter.

The areas which should be given special attention are:—

	Capacity.
West Hendon Playing Fields	450
York Park	300
Colindale Park	300
Montrose Playing Fields	550

and in order to make further progress it is necessary to employ a contractor who has in his own possession the necessary mechanical plant.

The Committee have authorised the Borough Surveyor to arrange with Howard Farrow Limited, to proceed with the trenches at West Hendon Playing Fields, York Park and Colindale Park on a basis of prime cost of labour and materials, plus a percentage addition for overheads to be agreed between the Contractor, the Borough Treasurer and the Borough Surveyor.

11.—SHELTERS FOR PERSONS CAUGHT IN THE STREETS:

The total number of shelters available for this purpose is 58 and the approximate accommodation provided therein is for 5,017 persons.

The shelters are fairly well distributed throughout the area and the necessary steps will be taken to requisition under the Civil Defence Regulations, other premises which are desirable for the purposes of air raid shelters.

12.—HOUSEHOLDERS' GARDEN SHELTERS:

19,220 circulars were sent to householders in connection with the proposed distribution of these shelters and 13,002 replies have been received. The number of addresses already supplied to the Home Office of persons qualified to receive these shelters is 5,731. 924 have been delivered by the Railway Company and as regards erection, the contractors have now approximately 66 men engaged on this work; over 300 shelters have been completed by the contractors, and about 150 by the householders themselves.

13.—RESCUE, DEMOLITION AND DECONTAMINATION:

This work has been provided for in three Depôts and a personnel of approximately 130 is always available on 24 hour shifts.

In addition, repair gangs for the repair of streets and sewers are stationed at the same three Depôts.

Sufficient transport has been secured for the use of the various squads, and the Committee are informed that it is not anticipated any difficulty will arise in the future in maintaining the service.

14.—PUBLIC LIGHTING:

The arrangements for blacking out the the public lighting have worked excellently.

The screening of traffic signals and illuminated direction signs was proceeded with in good time and was all complete when the emergency arose. The work of painting white lines on the streets has been completed and a gang set up to maintain the same in proper condition.

15.—ARRANGEMENTS FOR THE SUPPLY OF PETROL AND REPAIR OF VEHICLES:

The Committee have authorised the Borough Surveyor to proceed with the preparation of a scheme on lines approved in principle regarding the supply of petrol and repair of vehicles.

16.—AUXILIARY FIRE SERVICE:

(i).

Mobilisation.

The following eight Auxiliary Fire Stations have been taken over and each one is manned with four Home Office trailer pumps and the necessary personnel:—

Section.	Auxiliary Station.
No. 1—Edgware	Station Garage, Station Road, Edgware.
No. 2—Mill Hill	Mill Hill Fire Station.
No. 3—Burnt Oak	Messrs. Horrocks, East Road, Burnt Oak.
No. 4—Mill Hill East	Wentworth Hall Garage, The Ridgeway, Mill Hill.
No. 5—Colindale	Government Lymph Establishment, Colindale Avenue, N.W. 9.
No. 6—Hendon	Central Fire Station, Hendon.
No. 7—Child's Hill	Messrs. Greville's Garage, Finchley Road, N.W. 2.
No. 8—Golders Green	Messrs. H. A. Saunders Ltd., 616, Finchley Road.

There are six more pumps fully equipped and manned which can be used should the necessity arise. The remaining pumps will be allocated to the Auxiliary Stations as soon as the necessary equipment for them is received from the Home Office. At present, three Action Stations in each Section are manned when an air raid warning is received.

Approximately 300 auxiliaries have been called up for full-time service. 87 full-time and 142 part-time auxiliaries are available for service if required, but it has been found impossible to get into touch with the remainder of those who enrolled.

(ii).

Reciprocal arrangements.

Councillor Naar reported that questions of co-operation with other Authorities appeared to have arisen, and asked that the principle of reciprocity with neighbouring and regional areas already agreed by the Council should be re-affirmed. With the knowledge that in certain circumstances certain proportions of the fire equipment may be called upon for service outside the Borough, the Committee re-affirmed the principle of co-operation with other areas.

17.—SCHOOLS AND EDUCATION:

All schools have been closed, and they will remain closed until further instructions have been issued by the Education Committee.

A complete scheme of Trench Protection for school children has been prepared by the Borough Engineer. The estimated cost is £60,000. The Board of Education have approved the expenditure and it will rank for a 50 per cent. grant. Tenders for the work have been advertised and they were returnable on Thursday the 14th September.

18.—PUBLIC LIBRARIES:

Owing to the urgent necessity for attention to other buildings, it has not been found practicable to carry out any darkening of windows or blast proofing of these buildings, and in the circumstances the Committee have authorised the closing of all Public Libraries in the Borough one half-hour to the nearest half-hour before sunset.

19.—HOUSING OF DISTRESSED PERSONS:

The Committee are informed that arrangements are being made by the Public Assistance Authorities for the relief of distressed persons, and a scheme is in course of preparation for the utilisation of church halls and other buildings.

In order to provide a nucleus of accommodation, authority has been given for one vacant house on each of the Council's Housing Estates to be reserved for re-housing of homeless persons and/or for other temporary air raid precautions necessities.

20.—AIR RAID PRECAUTIONS OFFICER'S SALARY:

The members of the Council will, it is felt, be the first to appreciate that the outbreak of the war emergency has thrown a great responsibility on the Air Raid Precautions Officer who has, of course, assumed the position as Controller in war.

In these circumstances, the following decision was taken:—

That in view of the heavy responsibilities assumed as the result of the war emergency the salary of the Air Raid Precautions Officer and Controller be increased to £800 per annum rising by six-monthly increments of £50 to a maximum of £900—such scale to be applicable for a period of twelve months or to the conclusion of hostilities whichever is the earlier.

21.—ASSISTANT AIR RAID PRECAUTIONS OFFICER:

(a). *Appointment.*

Pursuant to the Special Sub-Committee's instructions, advertisements were issued for the appointment of a full-time Assistant Air Raid Precautions Officer. 105 applications were received and after interviewing four candidates the Sub-Committee appointed Mr. Frank J. Munns, Chief Clerk, A.R.P. Department, Bethnal Green, as full-time Assistant A.R.P. Officer at a salary in accordance with Grade C.2 of the Council's salary scale commencing at £300 per annum in accordance with the terms and conditions prescribed in the advertisement. A satisfactory medical report was submitted and Mr. Munns took up his duties under the Council on the 31st July.

(b). *Telephone.*

The Sub-Committee authorised the installation of a telephone at the private residence of the Assistant Air Raid Precautions Officer.

22.—TRAVELLING FACILITIES FOR A.R.P. DEPARTMENT STAFF—PURCHASE OF CAR:

The Sub-Committee authorised the purchase of a new car at a cost not exceeding £145 for the use of the Assistant A.R.P. Officer and the staff of the A.R.P. Department generally on official duties.

23.—APPOINTMENT OF TEMPORARY (A.R.P.) STAFF:

The Sub-Committee gave an open authority to the Air Raid Precautions Officer, the Borough Engineer and the Medical Officer of Health to engage such temporary technical, medical and clerical, etc., assistance as may be necessary for air raid precautions purposes.

In addition, the Sub-Committee considered as to the incidence of payment for temporary assistance, and gave directions for all junior clerical assistants and typists to be paid in accordance with the Council's salary scale, eliminating the payment of overtime.

24.—APPOINTMENT OF CHIEF AND DEPUTY CHIEF WARDEN:

The Air Raid Precautions Officer reported to the Special Sub-Committee that as a result of the abolition of Divisions consequent upon the re-organisation of the Wardens' Service, it was essential that a Chief Warden and a Deputy be appointed and that an efficient general assistant should be appointed to assist the Chief Warden.

The Air Raid Precautions Officer recommended that Captain A. G. Petrie (Divisional Warden of the North Division) be appointed Acting Chief Warden, and that Mr. F. Martin (Deputy Divisional Warden of the Central Division) be appointed Acting Deputy Chief Warden, and that confirmation of the appointments be considered at the expiration of a period of six months from 31st July, 1939.

The Sub-Committee approved the recommendations of the Air Raid Precautions Officer.

25.—APPOINTMENT OF GENERAL ASSISTANT TO THE CHIEF WARDEN:

The Special Sub-Committee considered as to the appointment of a general assistant to assist the Acting Chief Warden and his Deputy and agreed that subject to the approval of the Middlesex County Council an additional General Assistant be appointed to the staff of the Air Raid Precautions Department at a salary in accordance with Grade C.1 of the Council's Salary scale commencing at £240 per annum, and that the details in connection with the appointment be settled by the Chairman of the Committee (Councillor Arter) and the Air Raid Precautions Officer.

26.—A.R.P. HEADQUARTERS, RAVENSFIELD:

Inter communication telephones and clocks.

On the report of the Air Raid Precautions Officer to the Special Sub-Committee authority was given, subject to the approval of the Middlesex County Council, to the installation of an inter-communication telephone system at the A.R.P. Headquarters, Ravensfield at an estimated cost of £20. Authority was also given to the provision at Ravensfield of such clocks as may be necessary.

27.—CANTEEN SERVICE:

Considerable attention has been given to the question of providing the staffs at the various depôts with certain free meals (within the authority granted by the Home Office) and for obtaining refreshments at reasonable prices.

In connection with this service generally the Committee desire to place on record their appreciation of the valuable services of the Mayoress and Councillor Naar who have been working in close touch with the Borough Treasurer in the matter and also express their gratitude to the helpers in the Canteens who have ungrudgingly given so much of their time.

The matter continues to occupy the attention of the Committee but in the meantime catering arrangements operate at all depôts.

28.—FINANCE:

The personnel engaged may be broadly classified in the following groups:—

1. Administration and Control.
2. Wardens' organisations.
3. Engineer's organisations including decontamination, repairs and transport.
4. Medical Officer's organisation.
5. Civilian Deaths.
6. A.F.S.

Arrangements have been made for the payment of this personnel for the period ending 10th September in the approved proportions.

The Committee are conscious of the fact that the whole question of personnel requires very serious consideration and they view with consternation the possible standing about for weeks of people doing nothing, and in effect waiting for Air Raids to occur. At a very rough calculation this standby business is going to cost something like £10,000 per week in wages alone. The matter is receiving the most careful attention of the Committee.

29.—MESSAGE—LONDON CIVIL DEFENCE REGION CIRCULAR 45:

"The Regional Commissioners wish to express their appreciation of the good work done by all those concerned with Civil Defence in the Region during the past ten days. The Officers of the local authorities and many volunteers have worked very long hours under conditions of discomfort inseparable from the early days of mobilisation.

There has been remarkable and steady progress and the Commissioners are glad to feel that the Civil Defence Services have shown the same splendid spirit as the Fighting Forces.

The long hours for which many workers have been on duty must be imposing a strain on them which ought to be relieved as far as possible by giving spells of rest. It is impossible to lay down any standardised method of doing this; but local authorities should at once make plans for it and give effect by them. They may if necessary reduce the number on duty in parties or wardens' sectors below those stipulated but, if they do so, they should arrange for mobilisation of full strength at short notice. This message applies particularly to full-time personnel which has been on continuous duty and to part-time personnel on duty at night and doing their ordinary work by day. These last should not be required to do night duty on consecutive nights.

Please report as soon as possible a summary of action taken."

Action on the lines indicated in the message is being taken as far as practicable.

30.—LONG TERM POLICY:

The Town Clerk drew attention to the desirability of considering and as soon as practicable proceeding with a long term policy which would interfere as little as possible with ordinary civil activities. The Committee propose to undertake a complete review of each Service on a programme to be fixed, with a view to consolidating the existing organisation and/or proceeding to re-organise on a long term policy as circumstances permit.

(Signed) ERLAND ARTER (Chairman).

A. W. CURTON.

C. PINKNEY.

15/9/39.

Item 6 (iii)—Ambulances and First Aid Party Depôts.

Discussion ensued on consideration of the above item and the Council were informed of the steps which had been taken by the Emergency Committee with a view to obtaining the consent of the Middlesex County Council to an expenditure not exceeding £2,500 on the purchase and adaptation of 35 vehicles for ambulance purposes. The Council were informed of the many serious difficulties which the Committee had encountered in trying to build up a satisfactory ambulance service.

On the motion of Councillor Bridge, seconded by Councillor Hignett, it was

- 362.—RESOLVED—**That, in the opinion of the Council, the Emergency Committee should proceed forthwith, irrespective of the consent of the Middlesex County Council, with the provision of an adequate and efficient fleet of 35 additional ambulances at an estimated cost not exceeding £2,500 as contemplated in Item 6 (iii) of their report.**

Item 10—Trenches.

Motion moved by Councillor Curton, seconded by Councillor Pinkney, and

- 363.—RESOLVED—**That the question of the provision of trenches and shelter accommodation be considered by the Council in Committee this evening.**

Item 18—Public Libraries.

The Chairman of the Libraries Committee (Councillor Lightfoot) stressed the desirability of the windows of the Central Library and the Branch Libraries at Golders Green and Mill Hill being darkened to enable the Libraries to be kept open after dark.

After discussion, Councillor Pinkney gave an assurance that the Emergency Committee would give further consideration to the question of darkening the windows to enable the Libraries to be kept open after dark.

VOTE OF THANKS TO THE MAYOR:

Motion moved by Alderman Egan (Deputy Mayor), seconded by Councillor Curton, and

- 364.—RESOLVED unanimously—**That the cordial thanks of the Council be accorded to His Worship the Mayor for the large volume of work he has performed in his official capacity during the Recess and for the comprehensive report submitted by him thereon; and also to the Mayoress for her valuable services in connection with the canteen arrangements for the Civil Defence Personnel.**

The Mayor returned thanks on behalf of the Mayoress and himself for the sentiments embodied in the foregoing resolution.

ADJOURNMENT:

At 7.45 p.m., the Council adjourned to 8.15 p.m. this day.

RESUMPTION OF BUSINESS:

At 8.15 p.m. the Council resumed in Open Session.

Councillor Pugh gave notice of his intention to raise a matter at the meeting of the Council in Committee.

TRANSACTION OF LOCAL GOVERNMENT BUSINESS:

Upon further consideration of the question of the steps to be taken for the transaction of Local Government business for the period to the 9th November next (*vide* Agenda—Item 5), it was

- 365.—RESOLVED—**That all Committee work be undertaken by the Finance and General Purposes Committee who shall report to the Council, and that the matter be reviewed on or before the 9th November next with a view to all the Members of the Council being allocated to Committees.**

Herbert P. Better
Mayor

Council in Committee

18th September, 1939.

PRESENT:

His Worship the Mayor (Councillor H. G. Potter, J.P., F.S.I.), in the Chair.

The Deputy Mayor (Alderman S. H. Egan, J.P.).

Alderman W. M. Maughan, J.P.

Councillors:

E. Arter, M.C., M.I.A.E.,
T. K. Bridge,
F. J. Collins,
A. W. Curton,
J. Griffiths,
W. A. Hicks,
G. H. Hignett,

L. Hirshfield,
P. Lightfoot,
A. A. Naar, M.B.E.,
(Mrs.) F. E. Parvin,
C. Pinkney,
G. J. Pryke, F.I.A.C.,
A.M.I.S.E.,

T. Pugh,
G. R. Richardson,
W. H. N. Shakespeare,
M.C., A.F.C., J.P.,
H. P. Small,
(Mrs.) M. Thomas,
C. F. Windust.

AIR RAID PRECAUTIONS—PAID SERVICE:

Motion moved by Councillor Pugh:—

THAT no near relative of any Member of the Council shall be employed on any paid work in connection with Air Raid Precautions.

Debate ensued.

Motion moved by Councillor Shakespeare—subsequently withdrawn:—

THAT the Council do now proceed to the next business.

The Mayor ruled that Councillor Pugh had no right of reply to his motion as it had not been seconded, whereupon the motion was seconded by Councillor Bridge.

The motion was thereupon submitted and declared **lost**.

TRENCHES:

Councillor Curton reported on the position regarding the construction of trenches, and submitted suggestions for the acceleration of their construction. Upon consideration the Council decided to leave the matter for determination by the Emergency Committee.

The meeting terminated at 9.9 p.m.

Mayor

Reports of Committees.

Report (No. 1) of the Education Committee.

19th September, 1939.

COMMITTEE:

*Alderman J. J. Copestake, J.P. (*Chairman*).

Aldermen:

*S. H. Egan, J.P.,

B. Flowers,

*W. M. Maughan, J.P.,

Councillors:

*E. Arter, M.C., M.I.A.E.,

A. A. Naar, M.B.E.,

*W. H. N. Shakespeare,
M.C., A.F.C., J.P.,

*H. Connell, J.P.,

*(Mrs.) F. E. Parvin,

*H. P. Small,

*A. W. Curton,

*T. Pugh,

*(Mrs.) M. Thomas.

*G. H. Hignett,

*G. R. Richardson,

*P. Lightfoot,

*T. J. Scott,

Co-opted:

*Mrs. S. J. Bannister,

*Major N. C. Brett

*The Rev. P. C. Howell,

L.L.A.,

James, M.A.,

The Rev. I. Livingstone.

*The Rev. N. R. Boyd,

B.Litt., F.S.A.,

M.A.,

* denotes Member present.

An apology for absence was submitted on behalf of the Rev. I. Livingstone.

1.—MINUTES:

The Minutes of the Meeting held on the 4th July, 1939, were read, confirmed and signed.

2.—REPORT OF CHAIRMAN:

The following report was received from the Chairman as to his action taken during the Summer Recess, viz.:—

To the Members of the

HENDON EDUCATION COMMITTEE.

Ladies and Gentlemen,

The following matters have been dealt with during the time the Committee has been in Recess:—

(1) WAR ARRANGEMENTS:

- (a) All Schools were closed after Friday afternoon session, 1st September, and will remain closed until further instructions have been issued by the Education Committee.
- (b) A scheme of trench protection for school children has been prepared by the Borough Surveyor in respect of every school which can be used for educational purposes. Trenches have been planned in separate units to hold 50 children and the class teacher. Overhead cover is provided and internally the trenches will be lighted and contain adequate sanitary conveniences. The unit has been fixed at 50 to ensure that each class would have its own trench available. In each school a sufficient number of units of 50 has been provided to accommodate the number of classes.

- (c) On 30th August I instructed the Borough Engineer to advertise for tenders for carrying out the scheme which had been prepared. Tenders are due on Thursday, 14th September. The Borough Engineer estimated the cost at £60,000 and he based this figure on the assumption that the work could be carried out by contract at reasonable prices. The Board of Education have approved the Scheme and the expenditure and will pay grant at the rate of 50 per cent.
- (d) Eight schools, providing accommodation for 5,510 children (that is, one-third of available accommodation), have been requisitioned by the Government. The pianos at these schools have been transferred to other schools for the present.
- (e) Returns have been obtained from Head Teachers of the 48 Departments giving particulars of the following:—
- Meter readings at date for gas, water and electricity.
 - Fuel (coal, coke, firewood, etc.) in stock at date.
 - Caretakers' cleaning materials in stock at date.
- (f) All consumable school stock, Domestic Science materials, Handicraft tools, Science apparatus, etc., have been removed from children's desks, stock cupboards and practical rooms and stored under lock and key in stock rooms and, where necessary, in Staff rooms.
- (g) Head Teachers have collected and packed school records and school registers and have conveyed them to a place of safety.
- (h) All members of the Teaching Staff have been informed that, during any closure, their services are at the disposal of the Education Committee. Full information is available in respect of each teacher, showing whether he or she is engaged on voluntary National Service, and if not the form of service for which available when the opportunity affords.

(2) MAINTENANCE ALLOWANCES:

Authority was given for the award of Maintenance Allowances, under the Scheme approved by the Board of Education, to the following pupils in respect of the Summer Term, 1939:—

Orange Hill Central Boys' School:—

Bloxham, Arthur	Keetch, Robert George
Hills, Douglas	Rowe, Raymond William
James, Allan Leonard	Schneider, Norman Jack
	Terrell, Alfred George

Orange Hill Central Girls' School:—

Bowles, May Rose	Jones, Audrey Mary
Chapman, Rose Clara	Levy, Sadie
Cooper, Gladys Ena	Manning, Margaret Ivy
Finch, Doris Louise	Prendy, Dorothy Peggy
Hilton, Lily Joan	West, Rosie
Hill, Joyce Edith	Windle, Betty Rosina
	Walker, Elizabeth

St. Mary's C.E. Senior School:—

Carter, Cecilia Marian

(3) BROADFIELDS AVENUE JUNIOR AND INFANT SCHOOL:

Authority was given to the Architect to instruct the General Contractors to accept the following quotations for the items mentioned, subject to the Corporation accepting no direct financial responsibility:—

	£	s.	d.
Metal windows —Messrs. R. E. Pearse and Co. Ltd.	1,051	19	2
Constructional Steel Work —Messrs. Cook & Co.	476	0	0
Heating and Hot Water Supply —Messrs. Rosser & Russell	1,061	0	0

(4) BOARD OF EDUCATION AND MINISTRY OF HEALTH APPROVALS:

The following approvals were received:—

- (a) Broadfields Avenue School Site—£8,855. (Board of Education approval and Ministry of Health loan sanction.)
- (b) Broadfields Avenue School (erection). Ministry of Health loan sanctions. (Buildings £25,824; Heating £1,184.)

(5) EDGWARE SENIOR SCHOOL—ALTERATIONS AND EXTENSIONS:

Tenders have been received for carrying out the above work. His Worship the Mayor accepted the lowest tender, namely, that of Messrs. E. S. Moss Ltd., amounting to £20,500.

On 14th August application was accordingly made to the Board of Education for approval and to the Ministry of Health for sanction to raising a loan of £22,600, made up as follows:—

	£
Amount of provisionally accepted tender	20,500
Furniture and Fittings	850
Quantity Surveyor's fees	512
Salary of Clerk of Works	556
Legal expenses, cost of raising loan, etc.	182
	<hr/>
	£22,600

(Loan periods: Buildings not exceeding 40 years; Furniture not exceeding 10 years.)

(6) PLAY LEADERSHIP SCHEMES:

Two schemes similar to those established last summer were held during the holidays under the supervision of the Male Organiser of Physical Education. One scheme was held at Watling and the other, in co-operation with the Hampstead Borough Council, held at the Westeroft Estate Playground, Criklewood.

One paid Leader and one paid Assistant, who were qualified by experience and a course of three months at Loughborough College, were employed at each centre.

At Watling, the scheme opened on the Cressingham Road Playing Field, but after the first week it was found advisable, in order to preserve the surface for use during school hours, to move the games for older children and adults to Watling Park and, finally, to Montrose Park, the younger children remaining at Cressingham Road Playing Field for quiet activities only.

Both schemes were very successful judging by the following facts:—

- (a) The attendance at Watling was exceptionally high during the first week, as many as 1,000 being present at one session; this was due to the parents of the children not taking their holidays until August Bank Holiday week-end. Thereafter, the attendances showed a steady average figure of about 350 per session at Watling and about 180 per session at Westeroft.

- (b) There was a great variety of activities, *e.g.*, cricket, netball, English and Danish rounders, stoolball, tenikoits, skipping, hoops, and quiet activities—ludo, snakes and ladders, plasticine modelling, reading and community singing.
- (c) Senior pupils who attended the schemes last year were anxious to return to give assistance as Leaders in the various activities; in this way Play Leadership fulfils its function as a training ground for good citizenship.
- (d) An atmosphere of happiness, willingness to help others, good sportsmanship and respect characterised the schemes.

(7) ST. JOHN'S C.E. SCHOOL:

Authority was given for the Borough Surveyor to carry out urgent repairs to the floors of certain classrooms at this school, at an estimated cost of £42.

(8) COLINDALE SCHOOL:

The Borough Surveyor was authorised to provide curtains for the Assembly Hall at this school at an estimated cost of £40 for use in connection with a cinema projector.

(9) DEANSBROOK SCHOOL AND BURROUGHS PLAYING FIELD—A.R.P. TRENCHES:

I approved the suggestion of the Borough Engineer to construct trenches at Deansbrook School and Burroughs Playing Fields, subject to the condition that the normal use of these fields by school children should not be interfered with.

(10) DEFECTIVE CHILDREN:

In accordance with recommendations received from the School Medical Officer, the following arrangements have been made:—

- G.J., 14/10/26. Recommended for one month's convalescent treatment.
- P.Y., 12/5/27. Recommended for four weeks' convalescence at a Roman Catholic Home.
- H.F., 11/5/27. Recommended for four weeks' treatment at a Roman Catholic Home.
- A.W., 10/11/26. Recommended for one month's convalescence at a suitable Roman Catholic Home.
- M.D., 16/6/29. Recommended for four weeks' convalescence.
- F.B., 24/12/32. Recommended for one month's convalescence.
- W.B., 14/11/33. Extension of three months granted as from 11th August, 1939.
- A.S., 6/4/34. Recommended for admission to a residential open-air school for six months' treatment.
- L.S., 25/12/31. Recommended for one month's convalescent treatment.
- R.F., 15/6/28. Recommended for admission to a residential Roman Catholic School for feeble minded children.

(11) DOLLIS JUNIOR AND INFANT SCHOOL—RESIGNATION OF CARETAKER:

I accepted the resignation of Mr. A. H. Steeds, Caretaker of Dollis School, to take effect on 23rd August, 1939, and gave authority for the vacancy to be advertised. Applications for the post are now being received.

(12) ALGERNON ROAD SCHOOL PLAYGROUND:

Authority was given for the Middlesex Regiment to have the use of the Algernon Road School playground free of charge on 8th August, 1939, from 8--9 p.m. for parade purposes.

(13) HENDON SCHOOLS' SPORTS ASSOCIATION:

I am pleased to report that at the Middlesex Sports held on 28th June, the Hendon team again won the Lady Gott trophy. This is the third year in succession that Hendon has won this trophy. In the under 14 competition, Hendon were joint runners-up and held the Douglas Martin shield for six months.

J. Curtis (St. James' R.C. Central School) was awarded the Nias trophy for the best individual performance at the meeting.

(14) J.O.C.—SUMMER CAMPS:

Necessitous children have again been sent to the Seaside for a fortnight's holiday. The children were chosen with the greatest care from the most deserving cases in the Borough. The parties were as follows:—

64 boys to Walmer—12/8/39 to 26/8/39.

60 girls to Ryde—28/7/39 to 11/8/39.

The children had a splendid holiday and their health was obviously benefited by the sea air and the change of environment. Many parents have written, expressing most sincere thanks to the Committee for the wonderful holiday given to their children.

(15) ADMINISTRATIVE STAFF:

I have to report:—

- (a) That Mr. Ivan W. R. Ilsley commenced duty in the Education Department on 17th July, 1939.
- (b) That Miss Beryl Damen was appointed as temporary Junior Clerk in the Juvenile Employment Bureau in place of Mr. J. Cobb (on Military service) for duty as from 10th July, salary at the rate of £75 per annum.

(16) TEACHING STAFF ESTABLISHMENT, 1939/40:

A letter has been received from the Board of Education approving under Article 11 of the Code an establishment of 430 teachers for the year ending 31st March, 1940.

(17) APPOINTMENT FROM TRAINING COLLEGE:

In accordance with authority delegated, it was RESOLVED—

" THAT Miss Doris G. Edgar be appointed a Certificated Assistant Teacher on the Committee's Staff as from 29th August, 1939, in full-time service exclusively in the capacity of a teacher in accordance with the conditions of employment under Article 17 of the Code, and subject to the conditions of appointment of the Committee in force from time to time and upon the terms and subject to the conditions of the Burnham Arbitration Award and the decisions of the Board of Education relating thereto, or upon the terms and subject to the conditions of any other scale of salaries that may be adopted by the Committee, the engagement to be determinable on either side by a notice of one calendar month."

(18) NON-PROVIDED SCHOOLS—APPOINTMENTS:

Subject to the completion of Agreements with the Managers, satisfactory medical certificates having been received, I consented to the following appointments of Certificated Assistant Mistresses on the staffs of the schools mentioned:—

School.	Name of Certificated Assistant Mistress.	Date of Appointment.
St. Agnes' R.C.	Gahegan, Agnes	1st July, 1939.
Annunciation R.C.	Ronayne, Mary M.	1st September, 1939.
St. James' R.C.	Thornton, Mary	1st September, 1939.

(19) NEWLY APPOINTED TEACHERS FROM TRAINING COLLEGE:

The undermentioned teachers who were appointed from Training Colleges this year took up duties on the 29th August, 1939:—

Teacher.	School.
Aldred, Fred S.	Dollis Junior and Infants'.
Collier, Gladys M.	St. Mary's C.E. Senior.
Edgar, Doris G.	Wessex Gardens Girls'.
Evans, Margaret I. B.	Childs Hill Mixed.
Griffiths, Elizabeth E. M.	Brent Modern Domestic Science Centre.
James, Margaret F. H.	Woodcroft Senior Girls'.
Johnson, B.A., Arthur S.	Brent Modern.
Kedward, Kenneth R.	Wessex Gardens Boys'.
Knight, Margaret C.	St. Mary's C.E. Junior.
McKerchar, Grace M. A.	Algernon Road Domestic Science Centre.
Parkinson, Joyee M.	St. Mary's C.E. Senior.
Rivers, B.Sc., Frederick A.	Wessex Gardens Boys'.
Robinson, B.Sc., Albert	Garden Suburb Mixed.
Russell, Janet M.	Barnfield Infants'.

All the above, with the following three exceptions, have qualified as Trained Certificated Teachers:—

(a) Miss James, who was referred in English and Miss McKerchar, who was referred in Applied Science and Hygiene. Both will take the examination again in their respective subjects in 1940, but in the meantime salary will be paid at the Uncertificated rate of £108 per annum.

(b) Miss Evans, who has not yet received the result of her examination.

(20) STUDENT TEACHERS, 1939/40:

The undermentioned Student Teachers took up duties on 1st September, 1939:—

Student Teacher.	School.
Alexander, Frederick H.	Childs Hill Mixed.
Metcalf, Jean M.	Garden Suburb Infants'.

Miss Beryl G. Thomson failed to obtain Matriculation standard in the General Schools' Examination and her appointment was not, therefore, confirmed.

(21) TEACHERS, ETC., "CALLED UP" TO SERVE IN H.M. FORCES:

I have to report that the undermentioned teachers and caretakers have been "called up" for service in H.M. Forces:—

Name and School.	Date on which "called up."
(a) Teachers:—	
Bond, William H., Clitterhouse School	25th August, 1939.
Valentine, Herbert S., Wessex Gardens Boys' School	25th August, 1939.
Brien, D. Patrick, St. James' R.C. Central School	1st September, 1939.
(b) Caretakers:—	
Martin, Walter J., All Saints' C.E. School	24th August, 1939.
Marston, Ernest E., Brent Modern School	8th September, 1939.
Steeds, Arthur H., Dollis School	24th August, 1939.
Thomas, Oswald, Clitterhouse School	25th August, 1939.

(22) SCHOOL CARETAKER—ANNUAL INCREMENT:

I have given approval to the payment of a further scale increment of 1/- per week to Mr. E. E. Marston, Caretaker of the Brent Modern School, as from 12th October, 1939.

(23) RESIGNATIONS:

The undermentioned resignations of members of the teaching staff have been received and accepted:—

Teacher.	School.	Date of Leaving.	Reason.
Blake, Thomas H.	Edgware Junior	24/10/39	Retirement.
Brotheridge, Marjorie V.	Wessex Gardens Girls'	27/ 8/39	To take up an appointment under the Plymouth L.E.A.
Coombe, M.A., Kathleen I.	Orange Hill Central Girls'	31/ 8/39	To take up an appointment at the Hendon Technical Institute.
Edwards, Ernest	Brent Modern	31/ 7/39	Retirement.
Harper, Nancy E.	Hyde Infants'	8/ 9/39	Marriage.
Hill, Iris K.	Hyde Infants'	6/ 9/39	To return home.
Semple, Charles P.	Edgware Senior	30/ 9/39	Retirement.
Smith, John H.	Orange Hill Central Boys'	10/ 9/39	To take up an appointment as Headmaster of Rattlesden School, Suffolk.
Watson, Dora	Goldbeaters Senior	31/ 8/39	Marriage.

(24) RE-ORGANISATION OF SCHOOLS:**(a) CHILDS HILL AREA:**

A letter has been received from the Board of Education stating that the Authority's proposals for the re-organisation of the Public Elementary Schools in the Childs Hill Area appear to the Board to be satisfactory. The Board assume that the Authority will now consult the Managers of the All Saints' C.E. School with a view to obtaining their formal agreement to the closure of that school and request to be informed of the decision reached in due course.

(b) NON-PROVIDED SCHOOLS:

The undermentioned re-organisation of Non-Provided Schools was carried out on 29th August, 1939:—

St. John's C.E.:

Re-organised from All-Standard Girls' to Infant and Junior Girls' Department. All eleven-plus girls transferred to the Brent Modern and the Hyde Mixed Schools.

St. Mary's R.C.:

Re-organised from All-Standard to Junior Mixed and Infants' Department. Eleven-plus boys and girls transferred to St. James' R.C. Senior Mixed School.

St. Vincent's R.C.:

Re-organised from All-Standard to Junior Mixed and Infants' Department temporarily until the R.C. Orphanage School is available. Eleven-plus boys and girls transferred to the St. James' R.C. Senior Mixed School.

(25) DOLLIS COUNCIL SCHOOL:

A letter has been received from the Board of Education recognising Dollis Council School as providing accommodation for not more than 440 Junior Mixed and Infant children as from 1st May, 1939.

(26) REFUND OF EXAMINATION FEES:

I have given approval to the refund of the undermentioned examination fees in respect of pupils who have been successful:—

Brent Modern School:—

	£	s.	d.
R.S.A. Examination in Arithmetic—Stage I.	17	6	

Garden Suburb Mixed School:—

R.S.A. Examinations in English and Arithmetic and Pitman's Shorthand Examination, speeds 50 to 120	1	4	0
---	---	---	---

£2	1	6
----	---	---

(27) OXFORD SCHOOL CERTIFICATE EXAMINATION, 1939:

I have pleasure in reporting that at the Oxford School Certificate Examination held at the Orange Hill Central School in July last, candidates were successful as follows:—

School.	Number of Entries.	Number of successful candidates.
Orange Hill Central Boys'	15	10
Orange Hill Central Girls'	4	4
St. Mary's C.E. Senior Mixed	3	1

(Signed) **JOSEPH J. COPESTAKE,**

Chairman.

RESOLVED—

THAT the foregoing report be approved and adopted and that the best thanks of the Committee be accorded to the Chairman for his work during the Recess.

3.—AIR RAID PRECAUTIONS IN SCHOOLS:

(a) RE-OPENING OF ELEMENTARY SCHOOLS:

Consideration was given to a letter from the Board of Education stating that schools in neutral areas may be re-opened for instruction on or after 11th September at the discretion of the Authorities concerned. An important factor in determining whether schools in neutral areas shall be re-opened is the degree of protection available for the children while in school. Where such protection has not yet been afforded, Authorities are urged to complete the necessary measures with the least possible delay.

RESOLVED—

THAT the Hendon Elementary Schools be not re-opened until the necessary trench protective measures have been completed.

(b) WAR RE-ORGANISATION:

Having regard to the fact that eight Hendon elementary schools have been requisitioned by the Government, the Director of Education submitted a scheme of re-organisation for elementary education in Hendon during the period of war.

RESOLVED—

THAT the Scheme be approved in principle, that a copy of the Scheme be forwarded to each member and that the Director of Education be authorised to communicate with the transport companies concerned on the lines mentioned.

(c) TENDERS FOR AIR RAID SHELTERS AT SCHOOLS:

RESOLVED—

THAT this matter be dealt with in Committee.

4.—BROADFIELDS AVENUE SCHOOL:

(a) PROGRESS:

The Architect reported that work on this contract is only moving slowly. **Noted.**

(b) CONTINUANCE OF CONTRACT:

A letter was submitted from Messrs. A. McClelland and Co. Ltd. regarding difficulties which they are encountering in connection with the carrying out of this contract.

RESOLVED—

THAT this matter be dealt with in Committee.

5.—RAISING OF SCHOOL LEAVING AGE FROM 1/9/39:

The Director of Education reported with regard to exemptions on grounds of beneficial employment under the Education Act, 1936, and it was agreed that consideration thereof be deferred for the time being.

6.—KING GEORGE VI. SCHOLARSHIPS:

(a) FIRST SERIES, 1937/40—RENEWALS:

Satisfactory reports as to character, conduct, progress, etc., having been submitted, it was RESOLVED—

THAT the awards made to Amber Bryant and Stuart L. Carey in September, 1937, be renewed for a further year ending 31st August, 1940.

as carried out

Junior Girls'
at Modern andInfants' Depart-
' R.C. SeniorInfants' Depart-
Eleven-plus
School.Dollis Council
and Infant

tion fees in

£ s. d.

17 6

1 4 0

£2 1 6

ination held
s follows:—er of
candidates.

KE,

Chairman.

est thanks
during the

(b) SECOND SERIES, 1938/41:

It was agreed that Miss Joan Cooper be invited to attend for interview in connection with the renewal of her Award.

It was reported that Mr. E. A. Newman would not be able to continue his research work at London University for the degree of Ph.D., owing to war conditions, and it was agreed that the question of the renewal of the Scholarship in this case be held in abeyance.

(c) THIRD SERIES, 1939/42:

The Committee considered a summary of 7 applications received for the award of King George VI. Scholarships, Third Series, 1939/42.

RESOLVED TO RECOMMEND—

THAT Alderman Copestake and Councillor Curton be requested to interview the applicants, together with their parents, with power to act.

7.—PROPOSED ORGANISED ACTIVITIES FOR SCHOOL CHILDREN:

A letter was considered from the Watling Association regarding the possibility of organising a number of local groups to keep school children busy whilst the schools are closed and asking whether it would be possible for the Committee to grant the use of small halls in certain schools and the services of Teachers who may be available for the purpose of holding play hours, etc.

RESOLVED—

THAT the Watling Association be informed of the decision taken by the Education Committee with regard to re-opening of Schools.

8.—BURROUGHS PLAYING FIELD—SALE OF LAND:

Consideration was given to a memorandum from the Town Clerk regarding the proposal to sell to the Hendon Electric Supply Co. Ltd. a portion of land at the above-named Playing Field (F. & G.P.C., 20/3/39—Item 30). The proposed purchase price is £109, the District Valuer having given his valuation at the rate of £1 per square yard.

RESOLVED—

THAT the Education Committee concur in the proposal, subject to approval by the Board of Education.

9.—REPORT OF SCHOOL LIBRARIES JOINT SUB-COMMITTEE:

The Report of the School Libraries Joint Sub-Committee, dated 3/7/39, a copy of which had been circulated to each member, was approved and **adopted**.

10.—DOLLIS COUNCIL SCHOOL—APPOINTMENT OF CARETAKER:

It was reported that applications had been received for the above-named appointment caused by the resignation of Mr. A. H. Steeds.

RESOLVED—

THAT the applications be referred to a Special Sub-Committee, comprising Alderman Copestake and Councillors Curton, Richardson and Shakespeare, with power to make the appointment.

11.—TRANSACTION OF FUTURE BUSINESS:

RESOLVED—

THAT a Special Meeting of the Education Committee (in Committee) be held on Tuesday, 3rd October, 1939, at 6 p.m., for the purpose of transacting any necessary business.

Report (No. 2) of the Education Committee (in Committee).

19th September, 1939.

COMMITTEE:

*Alderman J. J. Copestake, J.P. (*Chairman*).

Aldermen:

*S. H. Egan, J.P.

B. Flowers,

*W. M. Maughan, J.P.,

Councillors:

*E. Arter, M.C., M.I.A.E.,

A. A. Naar, M.B.E.,

*W. H. N. Shakespeare,
M.C., A.F.C., J.P.,

*H. Connell, J.P.,

*(Mrs.) F. E. Parvin,

*A. W. Curton,

*T. Pugh,

*H. P. Small,

*G. H. Hignett,

*C. R. Richardson,

*(Mrs.) M. Thomas.

*P. Lightfoot,

*T. J. Scott,

Co-opted:

*(Mrs.) S. J. Bannister,
L.L.A.,

*Major N. C. Brett
James, M.A.,
B.Litt, F.S.A.,

*The Rev. P. G. Howell.
The Rev. I. Livingstone.

*The Rev. N. R. Boyd,
M.A.,

* denotes Member present.

An apology for absence was submitted on behalf of the Rev. I. Livingstone.

1.—BROADFIELDS AVENUE SCHOOL:

(a) CONTINUANCE OF CONTRACT:

RESOLVED—

THAT the contractors be requested to proceed with the work until the building has been roofed in and that the Board of Education be asked to approve, for grant purposes, any increased costs which may be involved over and above the original estimate owing to the state of war.

(b) SPECIALIST ITEMS:

RESOLVED—

THAT the Architect be authorised to instruct the General Contractors to accept the following quotations for the items specified, subject to no direct financial responsibility falling on the Corporation, viz:—

	£	s.	d.
Hollow Tile Flat Roofs:—			
Messrs. Windsor Floors Ltd.	363	14	3
Roof Tiling:—			
Messrs. Greenhams, Ltd.	554	13	6
Electric Lighting (Solid drawn conduit):—			
Mr. C. E. Keates	456	0	0

In the event of any or all of the above-named Contractors withdrawing their quotations, it was further RESOLVED—

THAT the Architect be authorised to negotiate with the Contractors who have submitted the next lowest quotations.

(c) HEATING TENDER:

A letter was submitted from Messrs. Rosser and Russell asking the Committee to agree to certain specified conditions in their Contract for heating installation, owing to the state of war.

RESOLVED—

THAT the matters raised be referred to the Architect and that he be authorised to make the best arrangements possible in the circumstances.

2.—AIR RAID PRECAUTIONS FOR SCHOOLS:

The Borough Surveyor submitted a scheme and plans for the provision of air raid shelters for elementary schools and reported on tenders received for carrying out the work. A schedule of such tenders had been duly circulated to each member of the Committee.

In connection with the ten schools mentioned, it was observed that it will be necessary to obtain authority to enter upon private land.

RESOLVED—

- (a) **THAT the Scheme as outlined in the Surveyor's report be approved.**
- (b) **THAT the Town Clerk be instructed to take the necessary steps to obtain authority to enter upon private land in respect of the Schools mentioned.**
- (c) **THAT a Special Sub-Committee, comprising Aldermen Copstake and Egan and Councillors Curton, Hignett and Pugh be authorised to interview the firms who have submitted the two lowest tenders, with power to place orders, and that all necessary steps be taken to expedite the execution of the work involved.**

The following motion, moved by Councillor Curton, seconded by Councillor Richardson, was **not carried**:—

“That the Air Raid Shelters for school children, when completed, shall be available to the public should they so desire, providing the shelters are not being used by school children at the time.”

Report (No. 3) of the Education Committee.

3rd October, 1939.

COMMITTEE:

*Alderman J. J. Copestake, J.P. (*Chairman*).

Aldermen:

*S. H. Egan, J.P.,
B. Flowers,

*W. M. Maughan, J.P.,

Councillors:

*E. Arter, M.C., M.I.A.E.,
H. Connell, J.P.,
*A. W. Curton,
*G. H. Hignett,
*P. Lightfoot,

A. A. Naar, M.B.E.,
*(Mrs.) F. E. Parvin,
*T. Pugh,
*G. R. Richardson,
*T. J. Scott,

*W. H. N. Shakespeare,
M.C., A.F.C., J.P.,
H. P. Small.
*(Mrs.) M. Thomas.

Co-opted:

(Mrs.) S. J. Bannister,
L.L.A.,
*The Rev. N. R. Boyd,
M.A.,

*Major N. G. Brett
James, M.A.,
B.Litt., F.S.A.,

*The Rev. P. C. Howell,
*The Rev. I. Livingstone.

* denotes Member present.

Apologies for absence were submitted on behalf of Councillor Connell and Mrs. Bannister.

REPORT OF THE EDUCATION COMMITTEE (IN COMMITTEE), 3/10/39:

Moved by Councillor Shakespeare, duly seconded, and RESOLVED—

THAT the following Report be received:—

3rd October, 1939.

(Members present as recorded above.)

1.—MINUTES:

The Minutes of the Meetings held on the 19th September, 1939, were read, confirmed and signed.

2.—BROADFIELDS AVENUE JUNIOR AND INFANT SCHOOL:

(a) INCREASED COSTS OF CONTRACT:

A letter was submitted from Messrs. A. McClelland and Co. Ltd. stating that owing to the present state of War there is a prospect of a rise in labour and that there is a rise at the present time in the cost of materials. The Contractors ask whether the Education Committee are prepared to pay the difference in labour and materials, taking as a basis the existing prices at the time of the commencement of the work on the Contract. The Director of Education reported that he had communicated with the Board of Education regarding recognition of increased costs for grant purposes, but at the moment no decision had been received from the Board.

RESOLVED—

THAT consideration be given to the application from Messrs. A. McClelland and Co. Ltd., provided they produce evidence showing that increased prices have been incurred by them over the prices ruling at the time of commencement of the Contract.

(b) SPECIALIST ITEMS:

The Architect reported that he had interviewed certain Sub-Contractors and had instructed the general contractors to accept the following quotations for the items specified, subject to no direct financial responsibility falling on the Corporation, viz. :—

	£	s.	d.
Heating and Hot Water Supply:			
Air Vent Heater Co. Ltd.	1077	0	0
Electric Lighting (solid drawn conduit) :—			
Mr. C. E. Keates	488	0	0
Roof Tiling:—			
Messrs. Greenham Ltd.	573	18	6

RESOLVED—

THAT the action taken by the Architect be approved and that any previous Minute inconsistent herewith be rescinded.

(c) COMPLETION OF BUILDING:

RESOLVED—

THAT immediate steps be taken to make the building wind and water tight; that the heating and electrical installation work be proceeded with, and that the completion of the building be carried out if and when the Board of Education approve, for grant purposes, any increased costs which may be incurred over and above the original estimate owing to the state of War.

3.—AIR RAID PRECAUTIONS FOR SCHOOLS—TENDERS FOR TRENCH PROTECTION:

Four meetings of the Special Sub-Committee have been held. Contractors interviewed, and a visit made to one Contractor for the purpose of inspecting plant.

In accordance with authority delegated, the special Sub-Committee RESOLVED—

- (a) **THAT** the tender of Messrs. Lavender, McMillan Ltd. of Worcester Park be accepted for constructing 147 trench units as specified for the Northern Section for the following sum:—

	£	s.	d.
147 Shelters	37606	9	4
Add extra for 46 concrete shelters, type "B" in lieu of type "A" (Steel) at £9 16s. 0d.	450	16	0
	£38057	5	4

- (b) **THAT** a further contract be let for constructing 77 additional shelters assumed at the same price as above, viz., £258 17s. 10d. each.

- (c) **THAT** the Corporation authorise application to the Ministry of Health for sanction to raising a loan of £59,500, for the maximum period permitted, made up as follows:—

	£	s.	d.
Amount of provisionally accepted tender for 147 shelters, with extras	38057	5	4
Amount of contract to be let for further 77 shelters	19934	13	2
Overground shelter for Broadfields Infants' Temporary School	500	0	0
Strengthening basements at St. Paul's C.E. and St. Agnes' R.C. Schools	200	0	0
Salary of Clerk of Works	300	0	0
Cost of raising loan, etc.	508	1	6
Total	£59500	0	0

(d) **THAT the Town Clerk be instructed to execute the necessary contracts and that the Corporate Seal be affixed to such contracts.**

4.—KING GEORGE VI. SCHOLARSHIPS:

(a) SECOND SERIES, 1938/41:

It was reported that Miss Joan F. D. Cooper had been interviewed by the Special Sub-Committee appointed for the purpose regarding the question of the renewal of her award for the year 1939/40, and that it had been agreed that the Director of Education should communicate with the Principal of Somerville College, Oxford, on the lines indicated.

After consideration of a further report upon Miss Cooper from the Principal of Somerville College, Oxford, the Committee **RESOLVED**—

THAT the first instalment of the Award (£25) for 1939-40 be paid to Miss Cooper and that her case be further considered after the Christmas holidays.

(b) THIRD SERIES, 1939/42:

It was reported that, in accordance with authority delegated, Alderman Copestake and Councillor Curton had interviewed five candidates, together with their parents, in connection with the award of these scholarships.

The Special Sub-Committee **RESOLVED**—

- (i) **That Miss Marion K. Blight, born 30/10/21, of 3, Ashbourne Mansions, N.W. 11, be awarded a King George VI. Scholarship, Third Series, 1939/42, of the annual value of £50 for three years, conditional upon her admission to Cirton College, Cambridge, in October, 1939, for the purpose of taking the Honours Course in Physics and Chemistry and subject to her compliance at all times with the terms and conditions attached to the holding of such scholarship as set out in the scheme.**
- (ii) **That Mr. Jack M. Shaw, born 18/12/19, of 37, Heming Road, Edgware, be awarded a King George VI. Scholarship, Third Series, 1939/42, of the annual value of £50 for three years, conditional upon his admission to the Imperial College of Science and Technology in October, 1939, for the purpose of taking a Degree in Mechanical Engineering and subject to his compliance at all times with the terms and conditions attached to the holding of such scholarship as set out in the scheme.**

Noted.

5.—RENEWAL OF MUSIC AND DANCING AND CINEMATOGRAPH LICENCES:

It was reported that, as a matter of urgency, Alderman Copestake and Councillor Curton had considered the question of making application to the Middlesex County Council for the renewal of Music and Dancing and Cinematograph Licences in respect of the nine schools mentioned, for the year commencing 13th November, 1939, and had decided, owing to the state of War, that such applications be not made.

Noted and approved.

6.—SCHOOL BUILDING DURING WAR:

Board of Education Circular 1477, a copy of which had been circulated to each Member, was submitted. The Circular contains the following general observations for the guidance of Local Education Authorities:—

- (a) Whilst there is no general embargo on school building, the existing situation must inevitably involve the postponement of the great majority of school projects for a period which is at present unascertainable.
- (b) Proposals for the provision of new public elementary schools, or for alterations or additions to existing public elementary schools, should be deferred, unless the Authority are satisfied that the proposals cannot be avoided, postponed or reduced.

Even in such cases the Board suggest that such proposals should be deferred for at least six months. **Noted.**

7.—VOLUNTARY SCHOOL:

A letter was submitted from the Watling Association stating that they had established a voluntary school to accommodate a certain number of children on the estate and asking whether the Committee would allocate a number of Hendon elementary school teachers to help with the work.

The Director of Education reported that, as an experiment, he had arranged for home visitations in a school area for the purpose of giving instruction to a limited number of children.

RESOLVED—

- (a) **THAT the question of extending the scheme of instruction through home visitation be left in the hands of the Director of Education.**
- (b) **THAT the Watling Association be informed that the Education Committee are unable to grant their request.**

8.—TEACHERS AND WAR SERVICE:

Board of Education Circular No. 1476 was submitted with regard to the Local Government Staffs (War Service) Act, 1939, and the Teachers' Superannuation (War Service) Act, 1939, which safeguard the salary and pension interests of teachers who, with the consent of their employers, join H.M. Forces.

RESOLVED—

THAT all teachers in the service of the Education Committee and teachers in the service of the Managers of Non-Provided Public Elementary Schools under the Committee who undertake war service as defined by the Local Government Staffs (War Service) Act, 1939, and the Teachers' Superannuation (War Service) Act, 1939, be granted such leave of absence as is required in connection therewith, and that their war service pay be made up, where necessary, to an amount not exceeding the amount of the remuneration which they would have received had they continued to serve as teachers under the Committee.

9.—TEACHING STAFF—RESIGNATIONS:

RESOLVED—

THAT the undermentioned resignations be accepted:—

Teacher.	School.	Date of Leaving.
Choyce, Jenny	Woodcroft Senior	30th September, 1939
Hall, Irene	St. Agnes' R.C.	31st October, 1939
Pool, Mary E.	Goldbeaters Infants	31st October, 1939

10.—ABSENCES OF TEACHERS AND ADMINISTRATIVE STAFF:

(a) TEACHERS:

It was reported that the undermentioned teachers had been granted special leave of absence, without salary, until further notice:—

Teacher.	School.	Date on which absence began.
Freeman, Doris L.	Clitterhouse	4/9/39
Henderson, Isobel L. M.	St. John's C.E.	7/9/39
Thompson, Margaret W.	Woodcroft Infants'	2/9/39

Noted.

(b) ADMINISTRATIVE STAFF:

Mr. A. Wright has been "called up" for Military duty and his special leave of absence began on the 21st September, 1939. **Noted.**

11.—TEACHERS' SALARIES—ANNUAL INCREMENTS:

With reference to Item 2 in the Report of the Staffs and Salaries Sub-Committee of 28th February, 1939 (confirmed by the Education Committee on 14th March, 1939), the Director of Education submitted a further report on the Assistant Mistress mentioned in MS. In view of the satisfactory nature of the report now presented, it was

RESOLVED—

THAT the annual increment previously withheld from the teacher concerned be now paid with effect as from 1st April, 1939.

12.—ST. AGNES' R.C. SCHOOL—PROPOSED RE-OPENING:

A letter was submitted from the Rev. G. H. Bishop stating that he proposed, subject to the consent of the Education Committee, to re-open this school in the near future by working two sessions, namely 80 juniors in the morning and 80 seniors in the afternoon. It is understood that there is a basement capable of affording adequate air raid shelter for 80 children, at least.

RESOLVED—

(i) **THAT the proposal of the Rev. G. H. Bishop, as outlined above, be approved, subject to the following conditions:—**

- That a safe emergency exit is provided for the basement mentioned.
- That additional columns are fixed to support the roof of such basement.

(ii) **THAT the Borough Engineer be instructed to give priority to this work in his scheme of trench protection.**

13.—ST. MARY'S C.E. SENIOR SCHOOL:

The Headmaster reported that, with the consent of the Chairman of the Managers, arrangements had been made for approximately 20 Senior children to use two rooms at the Church House for elementary instruction each morning.

It is understood that there is adequate air raid shelter accommodation for these children. **Noted and approved.**

14.—RE-OPENING OF SCHOOLS:

A letter was submitted from the Watling Association, enclosing a petition signed by a number of parents, urging the immediate opening of elementary schools on the Estate.

A letter signed by four members of the clergy, couched in similar terms, was also submitted.

RESOLVED—

THAT replies be forwarded to the above-named communications in the terms mentioned.

15.—REQUISITIONS:

Requisitions amounting to £1,587 9s. 4d. were submitted and **approved.**

16.—RECESS:

RESOLVED—

THAT any matters of urgency arising before the next meeting of the Committee be referred to the Chairman, with power to act.

Moved by Councillor Shakespeare, duly seconded and RESOLVED—

THAT the foregoing Report of the Education Committee (in Committee) be approved and adopted.

Report of the Emergency (Local Government) Committee (F. & G.P.C.)

2nd October, 1939.

COMMITTEE:

*Alderman W. R. Clemens, F.C.A. (*Chairman*).

Aldermen:

*J. J. Copestake, J.P.,

*S. H. Egan, J.P.
(*Deputy Mayor*),

B. Flowers.

Councillors:

*E. Arter, M.C., M.I.A.E.,

*P. Lightfoot,

*C. R. Richardson,

*F. J. Collins,

*A. A. Naar, M.B.E.,

*T. J. Scott,

*A. W. Curton,

*C. Pinkney,

*W. H. N. Shakespeare,

F. W. Gilpin,

*H. C. Potter, J.P., F.S.I.

M.C., A.F.C., J.P.

*G. H. Hignett,

(*Mayor*),

*H. P. Small.

*L. Hirshfield,

* denotes Member present.

1.—ACCOUNTS AND BALANCES:

(a).

Receipts.

The Borough Treasurer submitted the following statement of Receipts from the 1st June to the 30th September, 1939:—

	£	s.	d.
June	272916	7	1
July	249437	10	8
August	83488	11	6
September	201949	6	5
Total from June 1st to September 30th, 1939	£807791	15	8

(b).

Bank Balances.

The following statement was also submitted:—

	Credit.		
	£	s.	d.
31/8/1939	230346	19	10
14/9/1939	173613	9	11
15/9/1939	201620	3	0
16/9/1939	205267	12	7
18/9/1939	205334	3	1
19/9/1939	201186	17	11
20/9/1939	200792	9	8
21/9/1939	208513	18	11
22/9/1939	202906	7	10
23/9/1939	201517	1	4
25/9/1939	205921	18	3
26/9/1939	206370	17	0
27/9/1939	193560	6	6
28/9/1939	191646	2	2
29/9/1939	194361	0	5
30/9/1939	195605	18	11

2.—ACCOUNTS EXAMINED AND APPROVED FOR PAYMENT:

It was reported that pursuant to the Finance and General Purposes Committee's Instruction No. 2 and Resolutions of the Council, the following accounts as listed in the Expenditure Journal, had been examined and approved; that in view of the urgency of such accounts the necessary pay orders had been prepared and signed as authority to the Borough Treasurer to draw cheques, and that copies of such pay orders had been forwarded to the Corporation's Bankers with instructions to honour only such cheques as appeared in such Pay Orders.

List No.	Examined by.	General Account.		Loans Pool.	
		£	s. d.	£	s. d.
98/100	Councillor E. Arter	20124	16 1	—	—
101	Councillor E. Arter	106274	4 1	—	—
102/104	Councillor E. Arter	—	—	95053	2 6
105	Councillor E. Arter	23738	14 10	—	—
		£150137	15 0	£95053	2 6

Noted.

3.—REQUISITIONS:

The following requisitions were submitted and **approved**:—

	£	s.	d.
Public Health Department	52	16	6
School Medical Services	8	5	8½
Maternity and Child Welfare	767	8	8½
Libraries Department	368	19	6
Borough Engineer's Department	2902	16	10
Fire Brigade	562	14	7

4.—LOCAL OLD AGE PENSIONS:

It was reported that on the 22nd September, His Worship the Mayor considered 22 claims and 7 questions. One claim was adjourned and will be dealt with when further information is available as to the claimant's age. In the remaining cases decisions were given having the following effect:—

Claims:—

- 15 allowed at the full rate of 10/- weekly.
- 1 allowed at the rate of 4/- weekly.
- 5 disallowed, yearly means exceeding £49 17s. 6d.

 21

Questions:—

- 1 Pensioner entitled to a pension of 2/- weekly only instead of 6/- as from 10/8/39.
- 1 Pensioner entitled to a pension of 8/- weekly as from 4/8/39 instead of 2/-
- 1 Pensioner has been from and including 11/8/39 disqualified by reason of being detained in a Mental Hospital.
- 1 Pensioner not entitled to any pension as from 7/9/39.
- 1 Pensioner entitled to a pension of 6/- weekly as from 13/9/39 instead of 10/-.
- 2 Pensioners entitled to pensions at the rate of 10/- weekly as from 8/9/39 instead of 4/-.

 7

5.—ABSENCES:

STAFF.

It was reported that 18 members of the Staff had been absent owing to illness since the last meeting, three of whom are still absent.

6.—INCREMENTS:

The Committee considered the recommendations of the Chief Officers in cases due for scale increments for the period to the 1st November next, together with information as to service, grade, present salary, and the amount of increment due according to scale.

RESOLVED TO RECOMMEND—That scale increments be awarded in all cases recommended by the Chief Officers and enumerated in the Borough Treasurer's Report.

7.—APPOINTMENTS TO PERMANENT STAFF:

It was reported that the following employees would attain the age of 18 years on the dates stated opposite their respective names, and were recommended by the Chief Officers concerned for appointment to the permanent staff:—

Borough Treasurer's Department:—

Williams, J. A. 18/10/39

Public Libraries:—

Caws, Miss J. E. 17/10/39

Walton, Miss J. A. 24/11/39

Borough Engineer's Department:—

Harding, J. A. 17/10/39

RESOLVED TO RECOMMEND—That the employees enumerated above be appointed to the permanent staff as from the dates mentioned opposite their respective names at salaries according to the scale, subject to production of satisfactory medical reports.

8.—JUNIOR ENGINEERING ASSISTANT:

The Borough Surveyor submitted an application from Mr. N. S. Grassam, aged 17½ years, for appointment as an Assistant for training in engineering and surveying. Mr. Grassam has obtained the London School Certificate with exemption from Matriculation.

RESOLVED TO RECOMMEND—That Mr. N. S. Grassam be appointed as a Junior in the Borough Surveyor's Department on probation for a period of six months at a salary of £50 per annum.

9.—RE-GRADING—EDUCATION DEPARTMENT:

The Committee considered the report of the Director of Education recommending the re-grading of two Officers in his Department, and it was

RESOLVED TO RECOMMEND—That as from 1st October, 1939, Mr. R. Nicholls be placed in Grade B.1 of the Council's scale at a commencing salary of £360 per annum, and that Mr. G. L. Gibson be placed in Grade C.2 of the scale at a commencing salary of £300 per annum as from 1st November, 1939.

SUPERANNUATION.

10.—TRANSFER VALUES:

The Borough Treasurer reported the following transfer values payable to or by the Council:—

Committee's
as listed in the
the urgency of
as authority to
orders had been
such cheques as

Loans Pool.
£ s. d.
— — —

053 2 6

053 2 6

Noted.

£ s. d.
52 16 6
8 5 8½
767 8 8½
668 19 6
902 16 10
662 14 7

considered 22
when further
decisions were

6/- as from
stead of 2/-
reason of

head of 10/-
from 8/9/39

2.—ACCOUNTS EXAMINED AND APPROVED FOR PAYMENT:

It was reported that pursuant to the Finance and General Purposes Committee's Instruction No. 2 and Resolutions of the Council, the following accounts as listed in the Expenditure Journal, had been examined and approved; that in view of the urgency of such accounts the necessary pay orders had been prepared and signed as authority to the Borough Treasurer to draw cheques, and that copies of such pay orders had been forwarded to the Corporation's Bankers with instructions to honour only such cheques as appeared in such Pay Orders.

List No.	Examined by.	General Account.		Loans Pool.	
		£	s. d.	£	s. d.
98/100	Councillor E. Arter	20124	16 1	—	—
101	Councillor E. Arter	106274	4 1	—	—
102/104	Councillor E. Arter	—	—	95053	2 6
105	Councillor E. Arter	23738	14 10	—	—
		£150137	15 0	£95053	2 6

Noted.

3.—REQUISITIONS:

The following requisitions were submitted and approved:—

	£	s.	d.
Public Health Department	52	16	6
School Medical Services	8	5	8½
Maternity and Child Welfare	767	8	8½
Libraries Department	368	19	6
Borough Engineer's Department	2902	16	10
Fire Brigade	562	14	7

4.—LOCAL OLD AGE PENSIONS:

It was reported that on the 22nd September, His Worship the Mayor considered 22 claims and 7 questions. One claim was adjourned and will be dealt with when further information is available as to the claimant's age. In the remaining cases decisions were given having the following effect:—

Claims:—

- 15 allowed at the full rate of 10/- weekly.
- 1 allowed at the rate of 4/- weekly.
- 5 disallowed, yearly means exceeding £49 17s. 6d.

21

Questions:—

- 1 Pensioner entitled to a pension of 2/- weekly only instead of 6/- as from 10/8/39.
- 1 Pensioner entitled to a pension of 8/- weekly as from 4/8/39 instead of 2/-
- 1 Pensioner has been from and including 11/8/39 disqualified by reason of being detained in a Mental Hospital.
- 1 Pensioner not entitled to any pension as from 7/9/39.
- 1 Pensioner entitled to a pension of 6/- weekly as from 13/9/39 instead of 10/-.
- 2 Pensioners entitled to pensions at the rate of 10/- weekly as from 8/9/39 instead of 4/-.

7

STAFF.**5.—ABSENCES:**

It was reported that 18 members of the Staff had been absent owing to illness since the last meeting, three of whom are still absent.

6.—INCREMENTS:

The Committee considered the recommendations of the Chief Officers in cases due for scale increments for the period to the 1st November next, together with information as to service, grade, present salary, and the amount of increment due according to scale.

RESOLVED TO RECOMMEND—That scale increments be awarded in all cases recommended by the Chief Officers and enumerated in the Borough Treasurer's Report.

7.—APPOINTMENTS TO PERMANENT STAFF:

It was reported that the following employees would attain the age of 18 years on the dates stated opposite their respective names, and were recommended by the Chief Officers concerned for appointment to the permanent staff:—

Borough Treasurer's Department:—

Williams, J. A. 18/10/39

Public Libraries:—

Caws, Miss J. E. 17/10/39

Walton, Miss J. A. 24/11/39

Borough Engineer's Department:—

Harding, J. A. 17/10/39

RESOLVED TO RECOMMEND—That the employees enumerated above be appointed to the permanent staff as from the dates mentioned opposite their respective names at salaries according to the scale, subject to production of satisfactory medical reports.

8.—JUNIOR ENGINEERING ASSISTANT:

The Borough Surveyor submitted an application from Mr. N. S. Grassam, aged 17½ years, for appointment as an Assistant for training in engineering and surveying. Mr. Grassam has obtained the London School Certificate with exemption from Matriculation.

RESOLVED TO RECOMMEND—That Mr. N. S. Grassam be appointed as a Junior in the Borough Surveyor's Department on probation for a period of six months at a salary of £50 per annum.

9.—RE-GRADING—EDUCATION DEPARTMENT:

The Committee considered the report of the Director of Education recommending the re-grading of two Officers in his Department, and it was

RESOLVED TO RECOMMEND—That as from 1st October, 1939, Mr. R. Nicholls be placed in Grade B.1 of the Council's scale at a commencing salary of £360 per annum, and that Mr. G. L. Gibson be placed in Grade C.2 of the scale at a commencing salary of £300 per annum as from 1st November, 1939.

SUPERANNUATION.**10.—TRANSFER VALUES:**

The Borough Treasurer reported the following transfer values payable to or by the Council:—

Ref. No.	Name and Department.	Transfer Value.		Service to Count.	Payable
		£	s. d.		
931	Hopkins, Miss G.	86	5 2	8 years 3 months Non-contributing 1 year 3 months Contributing	To Croydon Corporation.
933	Morgan, Miss E.	97	12 6	9 years 7 months Non-contributing 1 year Contributing	To Croydon Corporation.
721	Mitchell, Miss M. E.	48	12 9	3 years 6 months Contributing	To Ipswich Corporation.
835	Wright, Dr. S. L.	217	15 0	1 year 4 months Non-contributing 2 years 6 months Contributing	To Wembley Corporation.
—	Fitzpatrick, Miss A.	97	11 2	3 years 11 months Non-contributing 3 years Contributing	By Birmingham Corporation.
—	Kite, Miss W. M.	1	1 0	2 months Non-contributing	By Bucks C.C.
—	Munns, F. J.	26	10 3	10 months Contributing	By Bethnal Green Corporation.

Noted.**11.—REFUND OF CONTRIBUTIONS:**

The Committee have learned with regret of the death of Mr. G. R. Fooks of the Public Libraries Department, and

RESOLVED TO RECOMMEND—That authority be given for payment of the sum of £12 7s. 6d. (refund of superannuation contributions) to the legal personal representative of the late Mr. Fooks.

12.—ISOLATION HOSPITAL STAFF:

For the purposes of the Local Government Superannuation Act, 1937, the following appointments on the hospital staff are placed on record:—

Permanent Staff:—

Connell, Miss B. M.	Staff Nurse as from 10/9/39.
Lewis, Miss M. M.	Staff Nurse as from 13/8/39.
McKenzie, Miss M.	Staff Nurse as from 2/9/39.
Thomson, Miss D. N. F.	Staff Nurse as from 2/9/39.
Walters, Miss M.	Staff Nurse as from 22/9/39.

Temporary Staff:—

Badham, Miss N.	Probationer as from 19/9/39.
Clark, Miss M.	Probationer as from 13/8/39.
Crookshank, Miss A.	Staff Nurse as from 12/7/39.
Horswell, Miss R.	Probationer as from 15/9/39.
Murphy, Miss K. M.	Probationer as from 16/8/39.
Ross, Miss M. M.	Probationer as from 28/8/39.
Sutherland, Miss N. E.	Probationer as from 28/8/39.

Noted.

13.—FIRE BRIGADE PENSIONS ACT, 1925:

It was reported that Fireman S. G. A. Lee and Fireman-Mechanic W. J. Baldwin had resigned their positions in the Fire Brigade to take up service under the fire brigades of Tunbridge Wells and Acton Corporations respectively.

RESOLVED TO RECOMMEND—That authority be given to the issue in each case of the necessary certificate of service and written consent to the transfer in accordance with Sections 6 and 7 of the Fire Brigade Pensions Act, 1925.

14.—ISOLATION HOSPITAL:

It was reported that as a matter of urgency, and owing to the special circumstances prevailing at the hospital at the present time, the Chairman of the Public Health and Medical Services Committee had approved of the wife of the Resident Medical Officer residing with him at the Isolation Hospital, and the provision of part board for the sum indicated in the Borough Treasurer's report.

RESOLVED TO RECOMMEND—That the action taken be approved.

15.—PRIVATE STREET IMPROVEMENTS—AGREEMENTS:

It was reported that 56 Agreements to pay Private Street Improvements Expenses by instalments had been completed since the last meeting. **Noted.**

16.—“ST. GEORGE'S,” THE BURROUGHS:

The Borough Treasurer reported that notice had been received terminating the tenancy of the above premises on the 24th April, 1940. **Noted.**

17.—235, THE BROADWAY, WEST HENDON:

An application was considered from the Lessees of the above premises to be released from their lease, which is due to expire on the 1st July next, for the reasons indicated in the Borough Treasurer's report.

RESOLVED TO RECOMMEND—That the Lessees of the premises be informed that the Council regret they are unable to grant the desired release.

18.—SUNDAY ENTERTAINMENTS ACT, 1932:

The Middlesex County Council have asked for the observations of the Town Council upon the application of the Hendon and Golders Green Orphan Aid Society to be included in the list of charities under the above Act. In view of the information furnished to the Committee, it was

RESOLVED TO RECOMMEND—That the Middlesex County Council be informed that the Council are unable to recommend the application for inclusion in the approved list at the present time.

19.—NORTH MIDDLESEX JOINT TOWN PLANNING COMMITTEE:

The Borough Treasurer reported that a copy of the Auditor's Report on the accounts of the North Middlesex Joint Town Planning Committee for the year ended 31st March, 1938, had been received, and that there were no items in the report and accounts to which special attention need be drawn. **Noted.**

LOANS.**20.—SHORT TERM LOANS:**

The Borough Treasurer reported that in accordance with the Council's decision, the following loans had been renewed for a period of 5 years certain on the revised terms approved by the Council on the 17th July last (F. & G.P.C., 10/7/39—19):—

366	£400
373	£200
B.56	£1000

It was also reported that notice had been received requiring repayment of the following short term loans to take effect on the 26th November, 1939:—

324	£1000
337	£1000
365	£2000
389	£1000

Loans Nos. 292, 293, 294 and 323 which were under notice to be repaid on the 21st October are to be renewed after that date on terms to be arranged. **Noted.**

21.—DEFENCE (FINANCE) REGULATIONS, 1939:

The Borough Treasurer reported on a circular, dated 13th September, 1939, issued by H.M. Treasury, which deals with certain defence Regulations and Orders which require that the consent of the Treasury be obtained to all issues of capital, renewal of securities, and the postponement of the date of maturity of securities.

The effect of the Circular in its application to the securities usually issued by the Corporation is that:—

1. No sanction or consent to the exercise of a borrowing power given prior to the date of the Circular may be operated without the further consent of the appropriate Government Department, unless the borrowing is for the purposes of the Air Raid Precautions Act, 1937, the Civil Defence Act, 1939, Water Supply, Hospitals and Fire Brigades.
2. No sanction or consent to the exercise of a borrowing power will be issued unless the purpose of the borrowing is of pressing necessity either for reasons of public need or on account of war requirements.
3. Until further notice no consent either of the Treasury or other appropriate Department will be required for the renewal by Local Authorities of maturing mortgages or Local Bonds or for the replacement of such Mortgages or Local Bonds by new Mortgages or Local Bonds. **Noted.**

INSURANCE FUND.**22.—CLAIM:**

It was reported that on the 21st August, 1939, No. 93, Fryent Grove was damaged by lightning, and that the estimated cost of reinstating the damage would amount to £5. **Noted.**

23.—NEW INSURANCES:

RESOLVED TO RECOMMEND—That the following insurances be carried by the Council's Fund:—

Description.	Value	Commencing	Annual
A.R.P. Emergency Food	for Insurance.	Date.	Premium.
Supply	£600	9/8/39	9/-
Public Convenience and Shelter at Wooderoft Park	£600	2/8/39	9/-

CIVIL DEFENCE ACT, 1939.**24.—GRANTS—PROVISION OF AIR RAID SHELTERS IN FACTORY PREMISES, COMMERCIAL BUILDINGS, ETC.:**

The Borough Treasurer reported that Messrs. Co-Partnership Tenants Ltd., had submitted an application for a grant under Section 22 of the Civil Defence Act, 1939, in respect of the provision of air raid shelter in connection with their premises at 166, Hampstead Way. **Noted.**

25.—ADVANCES TO OWNERS OF DWELLING HOUSES, ETC., IN RESPECT OF PROVISION OF AIR RAID SHELTERS:

The Borough Treasurer reported on an application from Messrs. S. M. & A. Mackover for an advance of £450 towards the cost of providing air raid shelter at Highfield Court, Highfield Road, such shelter to provide accommodation for 75-80 residents at Highfield Court, Melvin Hall adjoining and tenants of three or four small houses in Highfield Road.

Having regard to the information furnished to the Committee by the Borough Treasurer, it was

RESOLVED TO RECOMMEND—That the applicants be informed that the Council are unable to accede to their application for an advance under the Act.

26.—WAR TIME ADULT EDUCATIONAL ACTIVITIES:

The Town Clerk reported the receipt of a letter from the Director of Home Publicity, Ministry of Information, urging the importance of the normal continuation of all types of classes and lectures for adults and asking for the Council's co-operation in maintaining as active a programme as is possible under war conditions.

RESOLVED—That the matter be referred to the Chief Librarian for consideration and to submit a report thereon to the Council on the 9th instant.

27.—CHARITIES—REPRESENTATIVE TRUSTEES:

- (a) Nicholl's and Daniel's Charities.
- (b) Mrs. Burgess' Nursery Charity.

RESOLVED TO RECOMMEND—That Councillor P. Lightfoot be re-appointed as a Representative Trustee of the Nicholl's and Daniel's Charities, for a period of four years ending 30th September, 1943, and that Mr. A. S. Roberts be re-appointed as a Representative Trustee of the Mrs. Burgess' Nursery Charity, for a period of four years ending 30th September, 1943.

28.—CLASSIFICATION OF ROADS AND BRIDGES—DEANSBROOK LANE, ETC., A.5109:

The Committee have noted a letter from the Minister of Transport, forwarding formal declaration, pursuant to Section 17 (2) of the Ministry of Transport Act, 1919, declaring as a Class I. Road (No. A.5109), the route hitherto numbered B.553, commencing at a junction with Watling Street (A.5) at its junction with Deansbrook Lane, Edgware, and proceeding in a general easterly direction via Deansbrook Lane, Deans Lane, Selvage Lane, Marsh Lane, Highwood Hill (part), Totteridge Common and Totteridge Lane to a junction with the Great North Road (A.1) at Whetstone. For the purpose of advances from the Road Fund, the declaration became operative from the 1st April, 1939.

29.—BUILDING BYE-LAWS:

It was reported that the Minister of Health, on the 22nd July, 1939, duly confirmed the above Bye-laws made by the Council pursuant to a resolution passed on the 19th June last.

30.—RE-NAMING OF (PART OF) FINCHLEY LANE, HENDON:

The Town Clerk reported that no objections had been received to the proposal to re-name as Hendon Lane the section of Finchley Lane between Great North Way and the Borough boundary (viz., The Brook).

RESOLVED TO RECOMMEND—

- (i) **That under powers conferred by Section 18 of the Public Health Act, 1925, the Council do now, by order, assign the name Hendon Lane to the section of the road in question.**
- (ii) **That the Corporate Seal be affixed to the necessary Order.**

31.—HALE END FARM, FARM ROAD, EDGWARE—APPEAL OF MR. J. S. GOFF:

The Town Clerk reported that, in connection with the appeal of Mr. J. S. Goff against the refusal of the Council to permit the transfer of an existing private petrol pump to another position on land at Hale End Farm, the Minister of Health, after holding an enquiry into the matter, had dismissed the appeal. **Noted.**

32.—HOUSING ACTS—POSTPONEMENT OF WORKS—MINISTRY OF HEALTH
CIRCULAR NO. 1866:

The Committee received a report by the Town Clerk on the provisions of Circular No. 1866, dated the 8th September, 1939, issued by the Ministry of Health.

The Circular first deals with the question of slum clearance which does not, however, affect the Council in view of the fact that no schemes are at present in contemplation.

With regard to Demolition Orders, the Minister is of opinion that save in exceptional circumstances, the steps taken should stop short of actual demolition, as in view of possible destruction by attacks from the air, it is clearly desirable that the existing accommodation should not be diminished.

The Minister is not prepared for the time being to approve of the erection of further houses unless he is satisfied that there are exceptional circumstances which render the work of national interest, viz., that accommodation is necessary for employees of new factories or for agricultural workers. **Noted.**

33.—“HANDONE,” HOLDERS HILL ROAD:

The Council on the 28th February, 1938, approved the purchase of land adjoining “Handone” in connection with Holders Hill Road Improvement, at the price of £100.

Reasonable legal charges were also to be paid by the Council, but no agreement was arrived at to pay Surveyor's fees since negotiations were conducted with the Owner direct.

In connection with the agreed works carried out by the Council, however, the Owner had to instruct Surveyors and the Committee are informed that the reasonable fees of such Surveyors should be borne by the Council.

RESOLVED TO RECOMMEND—That the reasonable fees of the Owner's Surveyors, in connection with the agreed works, be paid by the Council.

34.—SHOPS (SUNDAY TRADING RESTRICTION) ACT, 1936:

An application, together with the necessary declaration, has been received from Mr. Israel Spivaek of 45, Hall Lane, N.W. 4, for registration for the purpose of Sunday Trading, in accordance with the provisions of the above Act.

RESOLVED TO RECOMMEND—That authority be given to effect the requisite registration in accordance with the provisions of the Act.

35.—REPAIR OF WAR DAMAGE—HOUSING ACCOMMODATION—MINISTRY OF HEALTH CIRCULAR NO. 1810:

The Committee have considered a report by the Town Clerk with regard to Ministry of Health Circular No. 1810 which imposes upon the Housing Authority the duty of supervising and carrying out of necessary repairs to housing accommodation rendered unfit for habitation by air bombardment or other war action.

As regards houses for the working classes, the duties which local authorities are required to undertake are substantially those already imposed by the Housing Act, 1936. The duties are extended to cover houses and other buildings which, although not working class houses, are being used or required to be used for the accommodation of the general population.

For the purpose of dealing with possible claims for compensation, the local authority is to compile a return after any damage has resulted from war action, for transmission to the District Valuer which will show amongst other things the number of buildings which are:—

- (a) totally destroyed,
- (b) so badly damaged that demolition is necessary,
- (c) seriously damaged but capable of repair,
- (d) slightly damaged.

In the case of occupied houses with damaged walls, roofs, etc., which could speedily be rendered wind and water-tight, by emergency repairs of a "first aid" nature, the immediate carrying out of which is essential to safeguard the health of the occupants and to prevent further damage to their belongings, the authority are empowered, without serving prior notice, to carry out such repairs, subject to the keeping of proper records of the cost in terms of time and materials of the work done on emergency repairs to **each house**. In the case of more permanent repairs, the local authority are required (with the consent of the Ministry of Health) to give not less than fourteen days notice to the person having control of the house or building that at the expiration of that time they propose to carry out the works named in the Notice, the estimated cost of which should also be given. The local authority are required to consider any representations made by the person having control of the house or building with a view to reaching agreement, but there would be no question of appeal against the works which the authority proposed to carry out or against their decision to do them.

It is not intended that the representative of the Minister of Health should inspect every property, before consent to the carrying out of more permanent works is given, but he will require to be satisfied that the number of premises on which more permanent repairs are to be undertaken bears a reasonable relation to the needs of the district. It is to be kept clearly in mind that the local authority's duty will not be to repair every house that has been damaged, but to see that repairs are carried out, or to carry out those repairs themselves, where necessary on such number of houses or other buildings used as housing accommodation as will ensure that a reasonable amount of habitable accommodation is kept going in their area. The Minister's representative will also be instructed to give special attention to houses on which it is proposed that more than the average amount of money is to be spent on repairs, and one relevant factor to which regard will be had will be the relation between the value of the property when repaired to the cost of repairs.

The cost of the works carried out by the local authority would be registered as a charge on the premises, but there would be no right of recovery until the end of the emergency. Local Authorities would obtain the necessary money to pay for the repairs by means of loans advanced by the Minister on terms and conditions approved by the Treasury, and normally there would be no repayments or interest charged in respect of these loans until the end of the emergency.

Local Authorities are required to make such arrangements as may be possible for securing that the "first aid" repairs can be effected immediately, and for this purpose it is suggested that the Council should get into touch with representatives of the building industry in the area and endeavour to arrange that small squads of men with the requisite plant and temporary materials could be sent out immediately to effect temporary repairs. Steps are being taken by the Government to ensure that a reasonably adequate supply of materials will be available.

The Committee have instructed the Town Clerk to consider and submit a report to the Council on the 9th instant, on the question of making representations to the Minister of Health, with a view to the owners of property which may suffer war damage being adequately safeguarded and, in the meantime, they

RESOLVED TO RECOMMEND—That the Borough Surveyor be instructed to make all necessary arrangements for the carrying out of the duties imposed upon the Council under the above-mentioned Circular.

36.—RENT AND MORTGAGE INTEREST RESTRICTIONS ACT, 1939:

The Town Clerk reported on the provisions of the Rent and Mortgage Interest Restrictions Act, 1939.

By this Act the provisions of the previous Rent and Mortgage Interest Restrictions Acts are to continue to apply to dwelling houses already controlled. In addition they are to apply to every dwelling house of which the rateable value in the Metropolitan Police District does not exceed £100.

It should be noticed that the Act does not apply to a dwelling house in respect of which a Local Authority has to keep a Housing Revenue Account under the Housing Act, 1936.

The Act came into operation on the 2nd September, 1939, and the question whether or not a house is controlled by this Act will depend upon the rateable value as on the 2nd September. **Noted.**

37.—ALLOTMENTS—CULTIVATION OF LANDS (ALLOTMENTS) ORDER, 1939:

The Town Clerk submitted the following report on the provisions of the above-mentioned Order:—

By this Order the Minister of Agriculture has delegated his powers as regards taking possession of land under Regulation 51 of the Civil Defence Regulations, 1939, to the Council. It enables the Council to take possession of any land in the district or outside the district which in the opinion of the Council can conveniently be cultivated or used by persons residing in the Borough for the production of food.

The Council's powers of taking possession are subject to certain restrictions:—

(1) they may not enter any garden or pleasure ground occupied, together with a dwelling house or any common land without the Minister's consent or any occupied land except with the written consent of the owner and occupier of the land.

(2) the sanction of the Minister is required if it is intended to enter on land for the purpose of using it for the keeping or breeding of live-stock.

- (3) notice should be given to the occupier and owner of the land as soon as possible after entry has been made.

In cases where by agreement the Council enter upon occupied land they may make a periodical payment for its use but such payment should not exceed the rental value of the land for agricultural purposes. If the land of which possession is taken is agricultural land, an additional sum may be paid such as might reasonably have been expected to be payable by an incoming tenant as regards growing crops, seeds and other similar matters. No account should be taken of any appreciation of value due to the national emergency.

Power is also given to the Council to make arrangements with any Society that has for its object the cultivation of vacant land with a view to the cultivation or use of the land upon which the Council has entered. The Minister considers that payments made to the Council by the occupiers for the use of the land should cover the cost incurred by the Council in providing land or adapting it for cultivation and the Council should not incur expenses that would involve the Minister in liability to repay an amount exceeding £2 per acre.

It should also be noticed that no payment at the termination of the tenancies should be made except as provided by the Allotments Act, 1922.

The object of the Order is to provide for the cultivation of land with a view to the growth of crops that come to maturity during the year. The land should not be used for grazing purposes nor for vegetable or fruit crops that continue productive for more than a year.

In connection with this matter, a letter from the Ministry of Agriculture and Fisheries, addressed to the Middlesex County Council, a copy of which was transmitted for the information of the Town Council, was considered. The letter states that it may be assumed that, during the war, a great and increasing interest will be taken in the production of food from allotments and private gardens and that large numbers of people will wish to grow, in their allotments and gardens, as much as possible of the vegetables and fruit which they need in their homes and that there will, therefore, be a great demand for advice and help and it will be desirable, from the outset, that the war effort should be so guided as to achieve its maximum result. In these circumstances, it is considered desirable that in all urban areas with populations of about 20,000, a Horticultural Committee should be set up, where such Committee is not already in existence, and that this Committee should be charged with the work of encouraging food production in allotments and private gardens. Such Committee, it is suggested, should include representatives of the Allotment Committee of the Urban authority, of Horticultural Societies and Allotment Societies, and of other persons interested in food production and gardening.

The letter also contains suggestions for providing advice to growers and intimates that a service of specialist advisers would be available for advice in cases of difficulty and to whom technical problems could be referred.

The Committee are informed that a large number of applications, for plots for cultivation as allotments, have already been received and the Borough Surveyor indicated certain sites, in the ownership of the Council, which it is considered would be suitable for cultivation as allotments. The Committee

RESOLVED TO RECOMMEND—That the matter be referred to a Sub-Committee, consisting of His Worship, the Mayor, Councillor F. J. Collins and Councillor C. F. Windust, with full power to take all necessary action with a view to the provision of allotments at the earliest possible date and to consider all applications for plots.

The Committee have instructed the Town Clerk to submit a report on the question of the termination of the tenancies of allotment plots allocated under the provisions of the above-mentioned order.

38.—LOCAL GOVERNMENT STAFFS (WAR SERVICE ACT), 1939:

This Act makes provision with regard (inter alia) to the pay and superannuation of employees of local authorities who cease to serve in their civil capacity, during the period of the present emergency, in order to undertake war service, which term includes civil defence service.

The Council, by resolutions passed on the 19th June last (F. & G.P.C., 12/6/39—13) decided that any employee (except casual employees) called upon for active service with the Forces of the Crown and/or Civil Defence Forces, should, whilst on active service, be paid his normal civil pay, less any service pay and allowances, and that the same provisions should apply, in the event of a war emergency, or any measure of general compulsory service being introduced, to all employees to whom permission to join the Forces of the Crown and/or Civil Defence Services had been refused in writing, but that, as far as any other employee was concerned, the application of the resolutions would remain to be considered.

By section 10 of the Act, a person shall not be disqualified for being elected or being a member of a local authority by reason only that he is employed in civil defence service for reward during the period of the present emergency, by or under the direction of the authority, and a person who is, or has been, a member of the authority shall not be disqualified for being so employed.

The Committee are of opinion that the Council should accept the provisions of the Act, and they accordingly

RESOLVED TO RECOMMEND—That the resolutions passed by the Council on the 19th June, 1939 (F. & G.P.C., 12/6/39—13), be varied to the intent that the making up of the difference between war service and civil pay be extended to include all teachers who were, at 1st September, 1939, on the permanent school teaching staff and all persons who had at that date been in the Local Government service or the service of the Council for at least two years and who are, or may be, called up for war service (including civil defence service).

The following are, however, excluded from the foregoing recommendation:—

(a) **In the case of Officers:—**

Those employees who were not contributors to the Superannuation Fund established by the Council under the 1922 Act and who have not been appointed to the permanent staff by resolution of the Council.

(b) **In the case of Servants:—**

Those employees who were not contributors to the Superannuation Fund established by the Council under the 1922 Act and who were not at that date eligible to be classified as "Servants Class A."

The terms "Officers" and "Servants" referred to above have the same meaning as they do under the Local Government Superannuation Act, 1937.

39.—PAYMENT OF WAGES DURING SICKNESS:

The Committee have received a report from the Town Clerk dealing with the question of payment of wages during sickness arising out of the case of *Marrison v. Bell*, which was decided by the Court of Appeal in February last, which decision showed that an employee was entitled to his wages while absent through sickness, notwithstanding that he received benefit under the National Health Insurance Act, 1936. The decision only applies to National Health Contributions and in cases where under the Workmen's Compensation Act a man is getting part of his wages in the form of compensation, that Act would suspend his right to the receipt of full wages during his incapacity. The principle established in this case, however, is that an employee is entitled to his full wages during sickness unless his contract of employment makes other provisions.

In order that the Council may be relieved of their liability to pay employees full wages during sickness, the Committee

RESOLVED TO RECOMMEND—That all employees to whom the decision in the case mentioned above applies should be requested to sign a form, to be prepared by the Town Clerk, making the Council's rules as to payment during sickness part of their contract of employment.

Highways Committee Matters.

40.—JUNCTION OF WATLING AVENUE WITH BARNFIELD ROAD—PEDESTRIAN CROSSING:

A letter was submitted from the Burnt Oak Chamber of Commerce suggesting that a pedestrian crossing should be provided in Watling Avenue at its junction with Barnfield Road, Burnt Oak.

The Borough Surveyor has reminded the Committee that a scheme for the provision of guard rails at this point has already been approved and he asked for the instructions of the Committee as to whether a pedestrian crossing should be included in the scheme.

RESOLVED TO RECOMMEND—That for the time being the scheme be limited to the provision of guard rails.

41.—APPROACHES TO DOLLIS COUNCIL JUNIOR AND INFANT SCHOOL:

At a previous meeting of the Highways Committee the Borough Surveyor was instructed to submit a scheme for dealing with the approach roads to the above school. Having regard to the existing conditions, however, the Committee have decided that no further action be taken in the matter for the time being.

42.—LITTER BASKETS, EDGWARE:

Arising out of a letter from the Edgware Chamber of Commerce asking for the provision of litter baskets at suitable sites in the Edgware district, the Committee have instructed the Borough Surveyor to deal with the matter in due course.

43.—DEDICATION OF PRIVATE STREETS:

The Borough Surveyor reported as to the desirability of dedicating as public highways repairable by the inhabitants at large, the following roads, which have been made up under agreements between the owners and the Council:—

Parsons Crescent, Edgware	Whole length.
Parsons, Grove, Edgware	Whole length.
Crossgate, Edgware	Whole length.
Wolmer Gardens, Edgware	Between a point 8 feet south of Crossgate and the north end of Parsons Crescent.
Glengall Road, Edgware	Between the watercourse running under the road and its junction with Kenilworth Road.
Morley Crescent, Edgware	Whole length.
Wyre Grove, Edgware	Whole length.
Warwick Avenue, Edgware	From a line drawn from the centre of the garage entrance of No. 71 to the south side of the garage entrance of No. 98, to its junction with Glengall Road.

Emergency (Local Government). 1060

Aldridge Avenue, Edgware ----- Whole length.
Marlborough Avenue, Edgware ----- From a line drawn from the back fences of the houses on the south side of Wyre Grove, to its junction with Glengall Road.

RESOLVED TO RECOMMEND--That the streets, or portions of streets, indicated above be now dedicated as public highways and the necessary notices duly posted.

EDGWAREBURY LANE, EDGWARE.

44.—EDGWARE WAY TO PARKSIDE DRIVE:

The Borough Surveyor submitted a letter from the Minister of Transport relating to the Council's application for a grant towards the expense of widening Edgwarebury Lane between Edgware Way and Parkside Drive.

The Minister is not prepared to consider a grant unless the whole road is dealt with from Edgware Way to Elstree Road as one complete scheme.

In these circumstances the Committee

RESOLVED TO RECOMMEND—That the scheme for the widening of the section of Edgwarebury Lane between Edgware Way and Parkside Drive be postponed.

45.—STATION ROAD TO EDGWARE WAY:

At the outbreak of war, work on the section of Edgwarebury Lane between Station Road and Edgware Way was approaching completion. The Borough Surveyor reported that instructions were received from the Minister of Transport to get the work, including the asphalt surfacing, completed as rapidly as possible, and that he had accordingly obtained tenders in the usual manner, and with the approval of the Minister of Transport the tender of Messrs. G. Wimpey & Co., Ltd., amounting to 4/4d. per yard super, including 2 years' free maintenance, was accepted. The whole of the work has now been completed and the road opened to traffic.

RESOLVED TO RECOMMEND—That the action taken by the Borough Surveyor be approved.

46.—FRITH LANE, MILL HILL:

The Committee have given instructions for all further action in connection with negotiations for the widening of Frith Lane, including the acquisition of certain property belonging to the London & North Eastern Railway to be deferred for the time being.

47.—MILL HILL BROADWAY BRIDGE—CONSTRUCTION OF CULVERT:

The Borough Surveyor reported that no further action has been taken in connection with the above improvement pending further instructions, and that the Minister of Transport will shortly communicate his decision with regard to all major schemes of road improvement. **Noted.**

48.—FINCHLEY ROAD IMPROVEMENT—CRICKLEWOOD LANE TO PORTSDOWN AVENUE:

The Borough Surveyor reported that the above improvement works were completed on the 9th August, 1939.

49.—CRICKLEWOOD LANE IMPROVEMENT—EDGWARE ROAD TO HENDON WAY:

The Borough Surveyor reported that in accordance with instructions from the Ministry of Transport it had been necessary to suspend work on this contract and to complete only those sections of the road which were open at the outbreak of war.

Noted.

50.—JUNCTION OF GREAT NORTH WAY AND FINCHLEY LANE:

The attention of the Committee was drawn to the unfinished condition of the above junction, and the Committee have instructed the Town Clerk to communicate with the Middlesex County Council urging that authority be given to complete the work forthwith.

Estates, Parks and Allotments Committee Matters.

51.—WATLING PARK—PROVISION OF SANITARY ACCOMMODATION:

The Committee decided to take no action on a letter from the Watling Association asking for re-consideration of their request for the provision of a convenience adjacent to the Bowling Green, Putting Green, and Tennis Courts in Watling Park.

52.—BASING HILL PARK—FENCING:

The Borough Surveyor reported on a letter from Mr. R. Harding, on behalf of the residents in The Vale, Golders Green, complaining of the damage to the fencing at the back of the gardens which forms the boundary to this Park, and suggesting that the Council should erect a suitable fence to protect their properties.

RESOLVED TO RECOMMEND—That no action be taken in the matter at the present time.

53.—ACCESS TO OPEN SPACES FROM PRIVATE PREMISES:

The attention of the Committee was drawn to numerous instances in which owners of properties abutting on to parks and open spaces in which trenches are constructed had provided access through their garden fences on to such parks and open spaces.

The Committee have instructed the Town Clerk to communicate with the owners of such properties in all cases brought to his notice.

54.—CHILDREN'S ENTERTAINMENTS IN PARKS:

A letter was submitted from Mr. A. Potter regarding the Children's Entertainments organised by the Estates, Parks and Allotments Committee in the various parks during the month. Mr. Potter estimates the total attendance at such entertainments at 6,910.

Noted.

55.—EDGWAREBURY PARK—CONVENIENCE AND DRESSING ROOM:

The Borough Surveyor reported that Mr. J. Norman Jones, whose tender amounting to £1,900 for the work of constructing conveniences and dressing rooms in Edgwarebury Park was accepted by the Council, had intimated that owing to altered conditions he was not in a position to sign the Contract. The Committee therefore

RESOLVED TO RECOMMEND—That the erection of the conveniences and dressing rooms in question be postponed for the time being.

56.—WATLING PARK—BANDSTAND:

The Borough Surveyor asked for instructions regarding the action to be taken in connection with the erection of the above bandstand, the contract for which, amounting to £479 3s. 1d., had been let to Messrs. G. H. Kempster Ltd. and in connection with which no work has yet been commenced.

RESOLVED TO RECOMMEND—That the erection of the bandstand in question be postponed for the time being.

*Buildings and Town Planning Committee Matters.***HENDON PLANNING SCHEME NO. 1.****57.—LAND—BURNT OAK BROADWAY:**

The Borough Surveyor reported on an application from the London County Council for consent to erect five blocks of three-storey flats on land facing the Edgware Road, forming part of the Watling Estate.

RESOLVED TO RECOMMEND—That consent be given (Clauses 35, 36 and 43).

58.—LAND—MALCOLM CRESCENT, HENDON:

An application was considered from Mr. W. F. Hobbs for consent to erect 56 flats and 13 garages on land at Malcolm Crescent, Hendon.

RESOLVED TO RECOMMEND—That consideration of the matter be deferred, pending an enquiry as to whether the applicant proposes to proceed further with the application.

59.—PROPOSED FISH FRYING BUSINESS—THE HYDE, HENDON:

The Borough Surveyor reported on an application from The Popular Fisheries Ltd., for consent to establish a fish frying business in a new shop at The Hyde, Hendon, just south-east of the junction with Sheaveshill Avenue. The application has been advertised in accordance with the provisions of Clause 30 of the Hendon Planning Scheme No. 1 and a number of objections have been received.

RESOLVED TO RECOMMEND—That consent be given (Clause 28), subject to a condition providing for the installation of modern apparatus of an approved type.

60.—8, BITTACY HILL, MILL HILL:

The Borough Surveyor reported on an application from Huntleys (Mill Hill) Ltd., for the re-consideration of the Council's refusal to consent to the establishment of a fish frying business at 8, Bittacy Hill, Mill Hill. The original application was advertised in accordance with Clause 30 of the Hendon Planning Scheme No. 1 and 25 objections from residents in the vicinity were received. (B. & T.P.C., 24/4/39-1). The applicant now submits a petition signed by approximately 150 local residents who are in favour of the establishment of the business.

RESOLVED TO RECOMMEND—

- (1) **That consent be given (Clause 28), subject to a condition providing for the installation of modern apparatus of an approved type.**
- (2) **That any previous resolution inconsistent with the foregoing be varied accordingly.**

61.—HIGHWOOD HILL TEA ROOMS, MILL HILL:

An application was considered from Mrs. Pring asking for a further amendment to her agreement with the Corporation to enable the above premises to be kept open to 10.30 p.m. instead of 10 p.m.

There would not appear to be any objection to the proposed amendment, and the Committee accordingly

RESOLVED TO RECOMMEND—That the application be approved.

62.—GARAGES, KING'S CLOSE, HENDON:

The Borough Surveyor reported on a letter from Mr. J. C. Cockram of 24, King's Close, complaining of the use of the existing buildings between Nos. 20 and 22, King's Close. Two applications for the business use of these premises have been refused by the Council and a notice under the Hendon Planning Scheme No. 1 was served in 1937 prohibiting the business use of the premises in question. (B. & T.P.C., 24/4/39—2). Recently new advertisement boards have been displayed and other alterations made.

RESOLVED TO RECOMMEND—That the matter be referred to the Town Clerk to take any necessary action.

63.—GARAGE PREMISES, NEAR DEANS DRIVE OFF EAST SIDE SEFTON AVENUE, MILL HILL:

A letter was considered from two residents in Sefton Avenue regarding the use of certain garages fronting the footpath between Sefton Avenue and Downhurst Avenue. It would appear that such garages are being used for various trade purposes and the land adjacent thereto, for a builders dump, in contravention of the Hendon Planning Scheme No. 1.

RESOLVED TO RECOMMEND—That the matter be referred to the Town Clerk to take any necessary action.

64.—COPTHALL PLAYING FIELDS, MILL HILL:

The Council made an Order on the 5th July last for the compulsory acquisition of 6.19 acres of land fronting Great North Way which is scheduled in the Hendon Planning Scheme No. 1 as a public open space. After further consideration of the matter in the light of present conditions, the Committee

RESOLVED TO RECOMMEND—That the matter be left in abeyance for the time being.

HENDON PLANNING SCHEME NO. 2.

65.—1, 3, 5, BRAMPTON GROVE, HENDON:

An application was considered from Messrs. Ranger, Burton & Frost, on behalf of the Salvation Army, for consent to the use of the site of the above premises for the purpose of a hall. Permission has already been given under interim development powers, and having regard to the Hendon Planning Scheme No. 2 becoming operative, the Committee

RECOMMEND—That consent be given (Clause 28).

66.—QUEENS HALL CINEMA, CRICKLEWOOD:

An application was considered from Mr. W. G. R. Saunders, on behalf of the Queens Hall Cinema, for formal consent under the Hendon Planning Scheme No. 2 to continue the business user at these premises.

RESOLVED TO RECOMMEND—That consent be given (Clause 54).

67.—BELMONT COURT, FINCHLEY ROAD, GOLDERS GREEN:

The Borough Surveyor reported on an application from Messrs. Murrell & Piggot for consent to the construction of a porter's flat at the rear of the above premises.

Having regard to the circumstances, as indicated in the Borough Surveyor's report, the Committee

RESOLVED—

- (1) **That consent be refused (Clauses 35, 36 and 43).**
- (2) **That such application be disapproved under the Restriction of Ribbon Development Act, 1935.**

68.—BUILDING APPLICATIONS:

The following applications were in order on submission and have been accordingly **approved** as indicated:—

Appl. No.	Description and Situation.	Public Health Act, 1936.	Town Planning.	Restriction of Ribbon Development Act, 1935.
A.824a	Alterations, 5, The Park, N.W. 11. Owner—Mr. Mannheim. Applicant—W. Bolton & Sons (Builders) Ltd.	Approved	Consent given (Clause 43 (3)) Condition:— That the distance between the north-east corner of the addition and the owner's north-east boundary shall not be less than three feet, and (Clause 28)—That the building shall only be used as a private residence for a single family	Approved.
A.8107a	Amended plan showing cart shed and living rooms over, St. Vincent's Convent, The Ridgeway, Mill Hill. Owner and Applicant—The Community of St. Vincent's Convent	Approved	—	—
A.8245	Addition, 14, Shirehall Park, Hendon. Owner—A. Wolff. Applicant—H. Francis Clarke	Approved	Consent given (Clause 42 (ii)) Condition:— That the proportion of site which may be covered by buildings shall not exceed thirty-three per cent., and (Clause 43 (3))—That the south-east wall of the addition may be erected up to the owner's south-east boundary	—
A.8259	Air raid shelter and store, 122, Brent Street, Hendon. Owner and Applicant—Boots Cash Chemists (Southern) Ltd.	Approved	Consent given (Clause 42 (ii)) Condition:— That the proportion of site which may be covered by buildings shall not exceed ninety per cent.	Approved.
A.8264	Garage, 7, Glenwood Road, Mill Hill. Owner—H. W. Sampson. Applicant—Astley, Brook & Co. Ltd.	Approved	—	Approved.

Appl. No.	Description and Situation.	Public Health Act, 1936.	Town Planning.	Restriction of Ribbon Development Act, 1935.
A.8265	Additions, "Load of Hay" Public House, Brent Street, Hendon. Owner and Applicant—Truman, Hanbury, Buxton & Co. Ltd.	Approved	Consent given (Clauses 28, 30 and 33) Condition:— That the site of the building and the adjacent car park shall form one land unit	Approved.
A.8268	Air raid shelter, 33, Crespiigny Road, Hendon. Owner—C. A. Turner. Applicant—A. J. Hill	Approved	—	—
A.8269	Air raid shelter, 16, Brampton Grove, Hendon. Owner—E. J. Huxtable. Applicant—A. J. Willson & Sons	Approved	—	—
A.8271	Internal W.C., 5, Mowbray Road, Edgware. Owner—Mrs. Stack. Applicant—F. Troy & Co.	Approved	—	—
A.8272	Air raid shelter, 147, North End Road, N.W.11. Owner—E. W. Hayward. Applicant—P. J. Preston	Approved	—	—
A.8273	Garage, 1, Cissbury Ring South, N. 12. Owner—B. E. Russell. Applicant—A. Escott & Son	Approved	—	—
A.8274	Addition, 22, Cumbrian Gardens, N.W.2. Owner and Applicant—S. Topping	Approved	—	—
A.8275	Air raid shelter, 5, West Heath Avenue, N.W.11. Owner—W. Brauer. Applicant—S. J. Franklin & Co.	Approved	—	—
A.8276	Air raid shelter, Highfield Court, Highfield Road, Golders Green. Owner—S. and N. Mackover. Applicant—Samuely and Hamann	Approved	—	—
A.8277	Air raid shelter, 16, Heming Road, Edgware. Owner—E. Sofaer. Applicant—Lawes & Sinfield	Approved	—	—
A.8279	Garage, 158, Station Road, Hendon. Owner—J. W. Turner. Applicant—C. Halls & Sons	Approved	—	Approved Condition:— That a crossing shall be constructed over the public footpath of Station Road; the work to be carried out by the Corporation after a deposit has been paid by the applicant to cover the estimated cost.

Appn. No.	Description and Situation.	Public Health Act, 1936.	Town Planning.	Restriction of Ribbon Development Act, 1935.
A.8250	Air raid shelter, "Courtleigh," Bridge Lane, N.W. 11. Owner—Burghey Properties Ltd. Applicant—Morris Joseph	Approved	--	--
A.8251	Air raid shelter and garage, 63, Woodland Way, Mill Hill. Owner—J. W. Peck. Applicant—W. F. Thorpe	Approved	--	--

Works and Fire Brigade Committee Matters.

69.—PUBLIC CONVENIENCE, FINCHLEY ROAD, GOLDERS GREEN:

On the report of the Borough Surveyor, the Committee

RESOLVED TO RECOMMEND—That the scheme for the erection of a public convenience in Finchley Road be deferred for the time being.

70.—HANDLING OF CONTAMINATED REFUSE:

The Borough Surveyor reported on a letter from the Hampstead Borough Council enquiring whether arrangements can be entered into for the destruction at the Council's Refuse Disposal Works of contaminated refuse from the Borough of Hampstead, as that Authority has no means of destroying it.

RESOLVED TO RECOMMEND—That, subject to financial arrangements being made to the satisfaction of the Borough Treasurer, and to the quantity of refuse to be delivered at any one time being strictly limited so that the Council's works are not overloaded, the Hampstead Borough Council be informed that the Town Council are prepared to provide the requisite facilities.

71.—FLOODING, GREYHOUND HILL:

The Committee decided to take no action on a letter from Mr. J. Brandstater regarding the alleged flooding of his premises.

72.—LAND, GREAT NORTH WAY, HENDON:

A letter was submitted from Mr. F. Wyatt of 4, Hilltop Gardens, making application to rent a plot of land owned by the Council adjacent to his premises.

RESOLVED TO RECOMMEND—That the application be granted subject to an agreement on terms to be arranged.

73.—HORSES:

Arising out of the report of the Borough Surveyor regarding the possible difficulties which may be encountered with mechanical transport and the desirability of obtaining further horses for the purpose of refuse collection, the Committee

RESOLVED TO RECOMMEND—That the Borough Surveyor be authorised to purchase up to six additional horses.

74.—PRIVATE WORKS:

The Borough Surveyor submitted the following statement as to Agreements which have been entered into pursuant to Section 291 of the Public Health Act, 1936, for the execution of private works:—

	Date of Agreement. 1939.	Amount of Deposit. £
Glendinning, W. M.—Crossings, etc., Granville Road	13th July	30
Hendale, Ltd.—Connection, Colindeep Lane	19th July	20
Foux, A.—Connections, West Heath Road	22nd July	50
Dale Metal Containers, Ltd.—Con- nection, Tennyson Road	21st July	25

	Date of Agreement. 1939.	Amount of Deposit. £
Oliver & Sons, Ltd., H. T.—Crossings, West Heath Road	24th July	65
Ekins & Co., Ltd.—Crossing, Page Street	2nd August	30
Garlick (1910), Ltd., J.—Connection, Ashley Lane	15th August	25
Varley Estates, Ltd.—Crossing, etc., Woodfield Avenue	15th August	40
Heath (Neasden), Ltd., T. W.—Con- nection, Woodfield Avenue	28th September	30
Garsubil, Ltd.—Connection, Edgware Road	28th September	35

Public Health and Medical Services Committee Matters.

75.—HEALTH SERVICES:

The Medical Officer of Health reported that, consequent upon the outbreak of war and the use of the Public Health staff in the casualty services, it was found necessary to reduce the social services to a minimum and, as three Health Centres are being used as First-Aid Posts, to acquire temporary premises at the Methodist Sunday School, The Burroughs, Hendon, and the Methodist Sunday School, Goodwyn Avenue, Mill Hill. The demand for the services, however, continues to increase and it will doubtless be necessary to have additional sessions of various kinds and, if extensive bombing does not take place, to re-establish these services, as far as possible, on a peace-time basis. In this connection, the Medical Officer is of opinion that it is advisable to hold a Child Welfare session at St. Mary Magdalene Church, Holders Hill Road, Hendon, which would serve the eastern side of Mill Hill and the Woodside Park Estate, the centre for the latter having had to be cancelled owing to the occupation, by the military authorities, of the premises previously used.

RESOLVED TO RECOMMEND—That the report of the Medical Officer of Health be approved and he be authorised, in consultation with the Chairman of the Public Health and Medical Services Committee, to arrange for such extensions of the services as may be found necessary.

76.—MILK ACTS, 1934-1938—MINISTRY OF HEALTH CIRCULAR NO. 1840:

The Ministry of Agriculture and Fisheries have made arrangements under the Milk Acts for increasing the demand by the supply of milk to nursing and expectant mothers, and children under 5 years of age at reduced rates. The supply of milk under this scheme to any family must be authorised by the Welfare Authority and the proposal to be made by any such Authority for the supply of such milk must previously have been submitted by the Welfare Authority to the Minister of Health and approved by the Minister after consultation with the Milk Marketing Board.

The scheme deals with the issue of free milk and milk, the cost of which shall not exceed 2d. per pint, and Local Authorities will be enabled to purchase their supplies at this figure.

Milk is at present distributed free by this Authority in accordance with column (1) of the economic scale set out below:—

Where the net weekly income per head of family per week does not exceed the following amounts:—

No. in family.	Column (1).	Column (2).	Column (3).
	s. d.	s. d.	s. d.
2	10 6	14 0	16 0
3	9 6	12 0	14 0
4	8 6	11 0	13 0
5	7 6	9 6	11 6
6	7 0	8 6	10 0
7 or over	6 6	8 0	9 6

Free. 1d. per pint. 2d. per pint.

The net income per head of family shall be defined as the income after Rent, Rates (including payments for arrears) compulsory insurances and fares to and from work have been deducted.

Income shall be calculated under the following headings:—

- (a) Wages.—Parents' or Guardians' weekly—the average for four weeks being taken.
- (b) Earnings of children.—Two-thirds of the net wages with a maximum of 30/-.
- (c) Income from lodgers to be reckoned on the following basis:—

Payments received from lodgers.	Proportion reckoned as income.
Up to 12/- per week	Nil.
Over 12/- per week	50 per cent. of surplus over 12/-.
- (d) Any sum received from sub-letting to be included in the family income.
- (e) The unborn child is counted as a member of the family.

RESOLVED TO RECOMMEND—

- (i) **That the distribution of milk be authorised at 1d. and 2d. per pint where the economic circumstances of the family fall within columns 2 and 3 respectively.**
- (ii) **That a scheme be prepared and submitted, for the approval of the Ministry of Health, the conditions as to estimated income to remain as set out in the Council's economic scale.**

77.—HOSPITAL NURSING—CONDITIONS OF SERVICE—MINISTRY OF HEALTH
CIRCULAR NO. 1832:

The above-mentioned Circular which was issued by the Ministry of Health on the 29th July, 1939, is based on recommendations made in the interim report of the Inter-Departmental Committee on Nursing Services. The attention of local authorities is drawn to the recommendations enumerated in the Circular and the Minister of Health expresses his confidence that Councils will wish to take an early opportunity of reviewing the present position in hospitals under their control, in the light of the views expressed by the Inter-Departmental Committee and to take such necessary action as may be immediately possible.

The Circular deals with accommodation, the relieving of nurses from domestic duties, the framing of rules so that discipline may not be restrictive, the desirability of providing adequate leisure and, generally, as to the welfare of the Nursing Staff. The Committee are informed that effect is being given to the recommendations as far as possible but the conversion of the greater part of the Isolation Hospital into a Casualty Clearing Hospital, and the change and increase of staff consequent thereon, will necessitate adjustments in the light of experience and after casualties have been received. In view of the conditions at present obtaining, consequent upon the emergency, the Committee decided to defer further consideration of the recommendations made in the Circular.

78.—ASSISTANT MEDICAL OFFICER OF HEALTH:

The Medical Officer of Health reported regarding the grant of a car allowance to Dr. MacLellan, the Assistant Medical Officer of Health, for general Public Health duties and, in particular, duties in connection with the administration of the Midwives' Acts, and also as to the desirability of a telephone being installed at the private residence of Dr. MacLellan.

RESOLVED TO RECOMMEND—

- (a) That a car allowance of £50 per annum be granted to Dr. MacLellan.
- (b) That a telephone be installed at the private residence of Dr. MacLellan; the rental to be paid by the Council.

79.—DEFECTIVE CHILDREN—EDUCATION ACT, 1921:

On the report of the School Medical Officer, it was

RESOLVED TO RECOMMEND—That in the under-mentioned cases, action be taken as follows:—

Case.	Defect.	Recommendation.
A.C., N.W. 11. Date of birth: 1/3/32. School: Not attending.	High Myopia	Admission to the Preparatory Department at Chorley Wood School for the Blind until 9 years of age and then admission to Worcester College until he attains the age of 11 years, when he would become chargeable to the M.C.C.
A.D., N.W. 2. Date of birth: 7/4/33 School: St. Agnes' R.C.	Chorea and Nervous Debility	2 months' convalescence and case to be reviewed prior to expiration of that period with a view to extension, if necessary.

80.—MATERNITY AND CHILD WELFARE ACT, 1918:

On the report of the Medical Officer of Health, it was

RESOLVED TO RECOMMEND—That in the under-mentioned case, action be taken as indicated:—

Case.	Defect.	Recommendation.
P.T., Burnt Oak. Date of birth: 31/3/36.	General Debility	4 weeks' convalescence.

81.—STATUTORY NOTICES—PUBLIC HEALTH ACT, 1936:

RESOLVED TO RECOMMEND—

- (a) That Statutory Notices under Section 45 of the Public Health Act, 1936, be served on the owners of the following properties:—

4, Cecil Road, Colindale, N.W. 9.
17, Cuddington Road, Cricklewood, N.W. 2.

(b) **That Statutory Notices under Section 48 of the Public Health Act, 1936, be served on the owners of:—**

47, Oak Grove, Cricklewood, N.W. 2.

ISOLATION HOSPITAL.

S2.—ROTA REPORT:

The following report was submitted:—

We, the undersigned, submit the following report of a visit made to the above-named Hospital on Monday the 18th September, 1939.

We considered tenders for supplies to the hospital during the six months ending 31st March, 1940, and decided to recommend acceptance of the following:—

Milk—Express Dairy Company, Limited.

Flour and Bread—A. Walkling, Limited.

Meat—H. B. Little.

With regard to other items, many of the firms tendering had indicated their inability to fix prices over a definite period, and it was decided in the following cases to continue purchasing from the present contractors, subject to the Matron being given authority to obtain supplies elsewhere if necessary:—

Item.	Present Contractor.
Jam, Marmalade and Redcurrant Jelly	Messrs. Scotts Preserves, Limited.
Remaining Groceries	Messrs. George T. Cox & Sons, Ltd. Messrs. J. F. Percival, Limited.
Provisions (excluding butter)	Messrs. G. T. Cox & Sons, Limited.
Butter	Messrs. J. Sainsbury, Limited.
Tea and Coffee	Messrs. R. Twining & Company, Limited.
Oilman's Goods	Messrs. Ronuk, Ltd. (Floor polish). Messrs. J. F. Percival (Palmolive soap, starch and scourers). Messrs. G. T. Cox & Sons (Toilet rolls and carbosil). Messrs. Pryke & Palmer (remaining items on Oilman's goods Schedule).

We visited the wards and found the isolation part of the hospital working satisfactorily. We were very much impressed with the amount of work which has been carried out in the remainder of the hospital, which is now an emergency hospital for war casualties, and we found everything there in a thorough state of preparedness. Two operating theatres, one X-Ray unit, and a reception block and three general wards with a total complement of 170 casualty beds were in readiness.

The black-out arrangements and the splinter proofing of the windows had been very satisfactorily carried out.

(Signed) M. Thomas.

T. J. Scott (Chairman).

W. M. Maughan.

RESOLVED TO RECOMMEND—That the report be approved and adopted.

83.—SURGICAL UNIT:

Prior to the outbreak of war the Ministry of Health agreed to the Council erecting a Surgical Unit at the Isolation Hospital. A letter has now been received from the Ministry of Health referring to the Treasury Circular, dated 13th September, 1939 (Defence [Finance] Regulations) and stating that, in the present circumstances, the Minister is not prepared, on the information before him, to issue his consent to the borrowing of the necessary moneys for the purpose and that any further action by the Council should be governed by the terms of the Treasury Circular. **Noted.**

84.—HEALTH CENTRE, NORTH OF EDGWARE WAY:

A letter was submitted from the Edgware Ratepayers' Association asking the Council to provide a Clinic in the vicinity north of Edgware Way to obviate the mothers and children having to travel long distances to the other Clinics provided in the Edgware Ward. The Association also ask whether a Community Centre could be provided to serve the needs of the residents in the area north of Edgware Way.

The Committee have instructed the Medical Officer of Health to submit a report on the matter in due course.

85.—CITY OF LONDON MATERNITY HOSPITAL:

An arrangement exists between the Council and the City of London Maternity Hospital whereby a monetary contribution is made by the Council in respect of expectant mothers residing in the Borough who are sent to the Hospital. A letter has now been received from the Hospital Authorities stating that in consequence of the outbreak of hostilities the Board are faced with a rapidly falling revenue and asking the Council to contribute on the basis of the full cost per patient during the continuance of the war.

RESOLVED TO RECOMMEND—That the Council agree to pay the full cost in respect of patients sent to the City of London Maternity Hospital during the continuance of the war.

86.—NORTH WESTERN CHILD GUIDANCE CLINIC:

On the 10th October, 1938, the Council agreed, in addition to paying the cost incurred in respect of cases sent to the North Western Child Guidance Clinic, to make a grant of £50 in respect of the year ending 30th September, 1939, and that the matter be reviewed at the expiration of this period.

A letter has now been received stating that owing to the outbreak of war it has been necessary to close the Clinic and that they will not be able to accept new cases nor to continue with those under treatment. In view of the closing of the Clinic no grant will be payable from the 30th September last, and the necessity for reviewing the position does not now arise.

87.—ROYAL NATIONAL ORTHOPÆDIC HOSPITAL:

The Medical Officer of Health reported the receipt of a letter from the Royal National Orthopædic Hospital stating that the Ministry of Health had informed them that under present conditions they are no longer at liberty to hold Clinics. Authority is, however, being sought to treat such orthopædic cases as require only short periods of hospital treatment, and if such authority is obtained certain cases on the Council's waiting list and such other cases as may be necessary will be called for treatment. The Council are asked to support the action being taken by the hospital authorities to obtain authority for the continuance of the Clinic.

RESOLVED TO RECOMMEND—That the Council support the efforts being made by the hospital authorities.

88.—INFECTIOUS DISEASE:

In connection with a case of Scarlet Fever, which could not be admitted to the Isolation Hospital owing to the use to which the hospital is at present put, the Town Clerk has been instructed to report on the legal position and on other aspects of the matter as indicated by the Committee.

Libraries Committee Matters.

89.—ADULT LENDING DEPARTMENT:

The Chief Librarian reported that since the first week of the war, when there was a slump in the use of books, there has been a steady recovery until now, when the volume of work averages 75 per cent. of the normal. The largest decrease (35 per cent.) is at the Golders Green Branch, and the smallest (15 per cent.) at the Central Library.

A number of readers have left the district, but those who remain are making more use of the service than before. While many are appreciative of the fact that the libraries have been kept open, a great majority take it as a matter of course, on the ground that books in war time are necessities and not luxuries. If the experience of 1914-1918 is repeated, the Committee are informed that as the war lengthens the demand for books will increase. In the first three weeks of September the number of borrowers registered (1,176) was only 119 short of the total for the corresponding weeks in 1938; an unusually large proportion of these (70 per cent.) being new readers. **Noted.**

90.—JUNIOR LENDING DEPARTMENTS:

Children are allowed two books on one ticket so that unnecessary journeys to the Libraries may be avoided. The number of children using the Central Libraries is now about the same as in normal times. At Golders Green, where many regular readers seem to have been evacuated, there has been a decrease of between 30 and 40 per cent. in attendances and issues. On the other hand the Mill Hill and Burnt Oak children are making more use of the Library than is usual in school holidays, and issues are increasing. **Noted.**

91.—LECTURES AND TALKS:

The Chief Librarian reported that the lectures and talks arranged for the session October—December have been cancelled. **Noted.**

92.—CLOSING OF LIBRARIES:

The Chief Librarian suggested that when the Library buildings have been satisfactorily "blacked out" the hours of closing during the winter months should be fixed as follows:—

Junior Department	5 p.m.
Other Departments	7.30 p.m.

RESOLVED TO RECOMMEND—That the suggestion of the Chief Librarian be approved and adopted.

93.—STAFF:

It was reported that consequent upon the resignation of Miss I. J. Ewin, a second vacancy exists for a Junior Assistant, but that in view of the shorter hours of opening the Chief Librarian suggested that the filling of these positions should be deferred for the time being.

A further vacancy has now occurred owing to the death of Mr. G. R. Fooks, and in this case also the Chief Librarian proposed deferring the filling of the vacancy thereby created.

The application of more normal hours of opening, or further depreciation of staff owing to enlistment of men of military age will, however, entail re-consideration of the question of staff at a later date. **Noted.**

Fire Brigade Matters.

STAFF.

94.—INCREMENTS:

The Committee have received a report with regard to increments due according to scale to members of the Fire Brigade Staff, and

RESOLVED TO RECOMMEND—That such increments be granted as from the appropriate dates.

95.—SICKNESS:

A report was submitted with regard to the absence of five members of the Fire Brigade owing to sickness, all of whom have now returned to duty.

96.—RESIGNATIONS:

The following resignations as from the dates indicated were reported:—

Fireman-Mechanic W. J. Baldwin (on appointment to Acton Fire Brigade)—7th September.

Fireman A. Lee (on appointment to Tunbridge Wells Fire Brigade) — 10th August.

Temporary Fireman F. H. Allen (on joining the Army)—6th July.

97.—TEMPORARY FIREMEN:

The Fire Superintendent reported that the following temporary firemen had been appointed on the dates stated:—

L. Williams	7th July.
A. J. Coley	7th July.
H. G. Payne	14th July.
G. G. Moore	24th July.
A. J. Henry	2nd September.

98.—CALLING UP OF RESERVIST:

The Fire Superintendent reported that, on the outbreak of war, Mr. G. H. R. Yabsley, who was on the roll as a Reservist, was called up for duty and is acting as Assistant Store-keeper of Auxiliary Fire Service Equipment. **Noted.**

99.—FIRE AND AMBULANCE CALLS:

The following is a statement of Fire and Ambulance calls received during the months of June, July and August:—

Fire Calls.				Ambulance Calls.			
Fire Calls	42	Private	286
False Alarms	11	Accidents	186
Inspections	4	Not required, etc.	38
			<hr/> 57				<hr/> 510

100.—INSPECTION OF FIRE APPLIANCES:

It was reported that the usual periodical inspections of fire appliances in schools, and public buildings had been carried out when the appliances were found to be in order.

Noted.

101.—PETROLEUM STORAGE LICENCES:

The following applications to store petroleum have been received:—

The Circular Car Sales, The Circus, Watford Way, N.W. 7	To store 30 gallons of petroleum in cans in an approved bin sunk into the ground.
--	---

The Express Dairy Co., Ltd., 15/17, Tavistock Place, W.C.1	To store an additional 6,000 gallons of petrol in underground tanks, at the Depôt, Claremont Road, N.W. 2.
---	--

RESOLVED TO RECOMMEND—That the applications be approved and the necessary licences issued in due course.

102.—FACTORIES ACT, 1937:

Inspections have been carried out under Section 34 of the Factories Act, 1937, at the under-mentioned premises:—

Messrs. Clang Ltd., Crown Yard, Cricklewood, N.W. 2.
The Lapointe Machine Tool Co., Forum End, Edgware.

RESOLVED TO RECOMMEND—That certificates as to means of escape in case of fire be issued in respect of such premises.

103.—FIRE HYDRANT:

It was reported that a fire hydrant had been fixed in Hendon Wood Lane, Hendon.

104.—CIVIL DEFENCE ACT, 1939:

The Fire Superintendent reported that numerous requests had been received from factories, works, and business houses in the Borough for fire drill instruction to be given to members of their Staffs under the provisions of the above Act, and that such requests are being acceded to, subject to the Council being completely indemnified in the matter.

105.—TWO-PLATOON SYSTEM:

A letter was submitted from the Fire Brigades' Union, requesting the Committee to receive a deputation consisting of two men from the Central Fire Station and an official of the Union, to discuss the question of the introduction of the two-platoon system.

RESOLVED—That the deputation be received at the next meeting of the appropriate Committee.

106.—FIRE BRIGADES' UNION:

Letters were submitted from the Fire Brigades' Union, regarding the system of examinations for members of the Fire Brigade and the employment of temporary firemen during holiday periods.

RESOLVED—That the communications be referred to the appropriate Committee for consideration.

107.—RETENTION OF TEMPORARY FIREMEN:

Owing to the large increase in Fire Brigade duties, due to the national emergency, the Fire Superintendent asked for authority to retain for the duration of the war the services of temporary firemen who were taken on for the holiday period. The Committee decided to refer the matter for consideration by the appropriate Committee.

108.—NEW LEYLAND FIRE ENGINE:

It was reported that the new Leyland Fire Engine had satisfactorily undergone the test laid down in the specification and general conditions, and is now in commission at the Central Fire Station. **Noted.**

109.—NO. 2 LEYLAND FIRE ENGINE:

On the recommendation of the Fire Superintendent, the Committee

RESOLVED TO RECOMMEND—That No. 2 Leyland Fire Engine be kept in commission and manned by auxiliary firemen at No. 8 Auxiliary Fire Station, Golders Green.

110.—NEW AUSTIN AMBULANCE:

It was reported that the new Austin Ambulance to replace No. 2 Talbot Ambulance had satisfactorily passed tests and is now in commission at the Central Fire Station.

Noted.

111.—DRIVERS AND DRIVING PAY:

The Fire Superintendent reported that he considered it necessary for all firemen at No. 2 Station to be trained as drivers and motor-pump attendants and that three of the firemen on Scale A were now qualified for driving pay.

RESOLVED TO RECOMMEND—That payment of 2/6d. per week driving pay be made to the three firemen on Scale A, viz., Firemen Doye, Goodchild and Hunt.

112.—APPOINTMENTS:

Owing to the great increase of work incurred by the calling-up of the Auxiliary Fire Service, and also the operation of the London Civil Defence Regional Scheme, the Chief Officer of the Fire Brigade reported that the following additional Officers are now necessary, in order that the work of the Brigade can be carried out efficiently:—

- (1) Deputy Chief Officer.
- (2) Motor Engineer.
- (3) Inspection Officer.
- (4) An additional Sub-Officer to carry on the work of Liaison Officer at the Report Centre.

The Chief Officer submitted the following recommendations for appointment:—

- (1) Deputy Chief Officer—Mr. J. L. Allman; at present Station Officer at the Central Fire Station.
- (2) Motor Engineer—a Motor Engineer in the employ of Leyland Motors Ltd. since 1916. (This recommendation is made in view of the fact that all the Council's appliances are of Leyland manufacture and it is desirable to have an Engineer who is fully conversant with this make of motor and pump.)
- (3) Inspection Officer — Sub-Officer C. H. Stevens.
- (4) Sub-Officer to be appointed from the present permanent staff.
- (5) Station Officer to succeed Mr. Allman.

After full consideration, the Committee

RESOLVED TO RECOMMEND—

- (i) **That Mr. J. L. Allman be appointed Deputy Chief Officer of the Fire Brigade at a commencing salary of £326 per annum, rising by annual increments of £13 10s. 0d. to a maximum of £380 per annum.**

- (ii) That Mr. J. L. Finney, of Leyland, Lancs., be appointed to the position of Motor Engineer at a salary of £5 per week, rising by annual increments of 2/6d. per week to a maximum of £5 10s. 0d. per week, plus quarters.
- (iii) That Sub-Officer C. H. Stevens be appointed to act as Inspection Officer for the duration of the war, on the understanding that such appointment is of a temporary nature.
- (iv) That the appointment of Station Officer (vice Mr. Allman) and a Sub-Officer be approved, in principle, and that the appointments be made by the appropriate Committee.

113.—STREET TRADING—WATLING AVENUE:

Pursuant to the resolution passed by the Council on the 19th June (H.C., 15/5/39—2), an enquiry was addressed to the Commissioner of Police of the Metropolis as to whether, in his opinion, the establishment of the proposed car park (H.C., 6/3/39—11) would adequately relieve traffic congestion to permit of the issue of a limited number of street trading licences in respect of Watling Avenue.

Whilst the Commissioner welcomes the proposal to establish a car park as one likely to assist in the improvement of traffic conditions generally in the district, he does not consider the presence of a neighbouring car park would in any way justify the issue of street trading licences in respect of Watling Avenue where the parking of cars is not a serious problem and where stalls in permanent positions might give rise to dangerous conditions.

In this connection a letter has also been received from Mr. G. W. Johnson, urging the Council to grant his application for a licence to engage in street trading in Watling Avenue. The Committee have referred the whole question for consideration by the appropriate Committee.

TRAVELLING FACILITIES.

114.—EDGWARE STATION VIA STONE GROVE TO CANONS PARK:

The Council, on the 19th June (H.C., 15/5/39—8), decided to make representations to the London Passenger Transport Board for the provision of an additional omnibus service or, alternatively, additional trolley buses on the route from Edgware Station (Underground) traversing High Street and Stone Grove to Canons Park.

In a letter from the Board, it is pointed out that until the introduction of trolley buses between Edgware and Canons Park, a 'bus route from Edgware to Boreham Wood (No. 141) connected Canons Park and Edgware Station, via Stone Grove and Station Road, but that this was then diverted via Edgwarebury Lane to meet the need for additional transport in that part of the Borough. The Board considered that this step was justified, in view of the very small number of local passengers to and from the station by the former route and, although requests were received for its restoration, it was not thought to be warranted. The matter was discussed by the Middlesex Traffic Sub-Committee.

The Board state that the position has not changed since that time and that observations show that the trolley bus service meets the present requirements reasonably. In these circumstances, the Board regret that they can see no sufficient grounds for reinstating the direct service from Canons Park, via Station Road and High Street, to Edgware Station (Underground).

In this connection, a petition, bearing the signatures of a number of residents in the Harrow area and also within the Council's area, has been received urging the reinstatement of the former 'bus service No. 141. A copy of the petition has also been forwarded to the London Passenger Transport Board and also to the Harrow Urban District Council. The Council are asked to support the petition.

Having regard to the conditions at present prevailing, the Committee

RESOLVED TO RECOMMEND—That no further action be taken in the matter.

115.—BUS SERVICE, NORTH OF EDGWARE WAY:

The Committee decided to take no action on a letter from Mrs. M. E. Cormack of Franklin Gardens, Edgware, urging the provision of a bus service to serve the area north of Edgware Way in the vicinity of Broadfields Avenue, and suggesting that one of the services (No. 113 or 240) should be diverted at Apex Corner, along Edgware Way, to Broadfields Avenue.

116.—COMMUNITY CENTRE—WATLING:

A letter was submitted from Mr. E. Sewell Harris, the Secretary of the Watling Association, relative to the Association's application for a contribution towards the cost of the extension to the Community Centre on the Watling Estate.

RESOLVED TO RECOMMEND—That no action be taken in the matter at the present time.

117.—POULTRY KEEPING:

A letter was submitted from the Clerk to the Middlesex War Agricultural Executive Committee asking the Council to do everything possible, in the light of present circumstances, to encourage people, who have reasonable facilities, to take up poultry keeping, and suggesting that consideration should be given to the desirability of removing any restrictions banning the keeping of poultry in back gardens on the Council's Housing Estates during the period of the war in cases where reasonable facilities exist.

RESOLVED TO RECOMMEND—That any restrictions on the keeping of poultry in back gardens on the Council's Housing Estates, in cases where reasonable facilities exist, be relaxed as far as possible during the period of the war.

118.—EDUCATION COMMITTEE—RESIGNATION OF MRS. S. J. BANNISTER, L.L.A.:

The Committee have received and noted a letter, dated the 25th September, addressed to the Director of Education by Mrs. S. J. Bannister, L.L.A., tendering her resignation forthwith as a co-opted Member on the Education Committee.

119.—GOLDERS GREEN FOOTBALL CLUB:

A letter was submitted from the Hon. Secretary of the Golders Green Football Club asking the Council to waive, for the duration of the war, payment of rent and rates in respect of the ground used by the club at Clitterhouse.

The Committee have instructed the Borough Treasurer to report as to the financial position of the club at a later date.

120.—LOCAL GOVERNMENT—WAR TIME ORGANISATION OF COMMITTEES:

Pursuant to the resolution passed by the Council on the 18th September, the Town Clerk submitted the following scheme for the carrying out of local government business after the 9th November next:—

SCHEME FOR WAR TIME ORGANISATION OF COMMITTEES.**GROUPING OF STANDING COMMITTEES.****Group I.**

Public Health and Medical Services.
Housing.
Libraries.
Works and Fire Brigade.

Group II.

Highways.
Town Planning.
Estates, Parks and Allotments.

Finance and General Purposes Committee
(including Rating and Valuation).

MEETINGS OF COMMITTEES AND COUNCIL.

Group I. and II. to meet concurrently on the first Monday.

Finance and General Purposes Committee to meet on Wednesday week following Group I. and II. Committees (except in March, 1940, owing to Easter).

Council to meet on Monday week following Finance and General Purposes Committee.

DATES OF MEETINGS.**Annual Meeting of Council—9/11/39.**

Group I. and Group II.	Education.	Finance and General Purposes Committee.	Council.
13th November	14th November	22nd November	4th December (Ordinary).
XMAS VACATION			8th January (Special).
8th January	9th January	17th January	29th January (Statutory).
5th February	6th February	14th February	26th February (Ordinary).
4th March	5th March	11th March (Monday)	18th March (Ordinary).
EASTER VACATION			1st April (Special).
1st April	2nd April	17th April	29th April (Statutory).
WHITSUN VACATION			20th May (Special).
20th May	21st May	29th May	10th June (Ordinary).
17th June	18th June	26th June	8th July (Statutory).
MIDSUMMER VACATION			16th September (Special).
16th September	17th September	25th September	7th October (Statutory).

RESOLVED TO RECOMMEND—That the scheme for the war time organisation of Committees set out above be approved and adopted, and that the letting of houses on the Council's Housing Estates; routine matters relating to Rating and Valuation and other matters of detail be dealt with as far as possible by the Officers concerned.



These digital images are
the copyright of
The London Borough of
Barnet 2017

Minutes.

At a Statutory Meeting of the COUNCIL of the BOROUGH OF HENDON, held at the Town Hall, The Burroughs, Hendon, N.W. 4, on Monday, the 9th day of October, 1939, at 6 o'clock p.m.

PRESENT:

His Worship the Mayor (Councillor H. G. Potter, J.P., F.S.I.), in the Chair.

The Deputy Mayor (Alderman S. H. Egan, J.P.).

Aldermen:

**W. R. Clemens, F.C.A.,
J. J. Copestake, J.P.,**

**W. M. Maughan, J.P.,
A. J. Reynolds, J.P.,**

R. A. B. Teare, M.B.E.

Councillors:

**E. Arter, M.C., M.I.A.E.,
F. H. Bate,
T. K. Bridge,
F. J. Collins,
H. Connell, J.P.,
E. J. Cox,
A. W. Curton,
A. W. Creville,
J. Griffiths,**

**W. A. Hicks,
C. H. Hignett,
L. Hirshfield,
P. Lightfoot,
A. A. Naar, M.B.E.,
(Mrs.) F. E. Parvin,
C. Pinkney,
C. J. Pryke, F.I.A.C.,
A.M.I.S.E.,**

**T. Pugh,
C. R. Richardson,
T. J. Scott,
W. H. N. Shakespeare,
M.C., A.F.C., J.P.,
H. P. Small,
(Mrs.) M. Thomas,
C. F. Windust.**

NOTICE OF MEETING:

The Town Clerk read the notice convening the Meeting.

MINUTES—CONFIRMATION:

Moved by Alderman Copestake, seconded by Alderman Maughan, and
366.—RESOLVED—That the Minutes of the Special Meeting of the Borough Council held on the 18th day of September, 1939, be confirmed.

APOLOGY FOR ABSENCE:

An apology for absence was submitted on behalf of Alderman F. C. Rice.

ELECTION OF ALDERMAN:

The Mayor directed the Town Clerk to distribute voting papers to the Councillors present for the election of an Alderman to fill the vacancy caused by the death of Alderman B. J. Monro.

The voting papers having been completed in due form were delivered to the Mayor, who thereupon openly produced them and instructed the Town Clerk to read the same.

The voting was as follows:—

Councillor G. R. Richardson 21 votes.

The Mayor thereupon declared Councillor G. R. Richardson to be duly elected as an Alderman of the Borough for the period ending on the 9th November, 1944, and congratulated him on receiving an unanimous vote.

The newly-elected Alderman subscribed the declaration prescribed by law and returned thanks for his election.

QUESTION:

Civil Defence.

In reply to Councillor Pugh, who asked the Chairman of the Emergency Committee whether he would give the Council this evening a full report of the meeting held on the 27th September between the County Emergency Committee and the Borough Emergency Committee, and also a report on the subsequent action of the Borough Emergency Committee in relation thereto, the Chairman of the Emergency Committee (Councillor Arter) stated that the meeting in question was referred to in the report of the Emergency Committee presented to the Council that evening, and he had nothing further to add.

REPORTS OF COMMITTEES.

EDUCATION COMMITTEE:

REPORT NO. 1.

Moved by Alderman Copestake, seconded by Councillor Scott, and

367.—RESOLVED—That Report No. 1 of the Education Committee (Meeting held on the 19th September, 1939—Agenda, pages 1029-1038) be received.

ADOPTION OF REPORT:

368.—RESOLVED—That Report No. 1 of the Education Committee in so far as it relates to matters requiring the confirmation of the Council, be approved and adopted.

REPORT NO. 2.

Moved by Alderman Copestake, seconded by Councillor Scott:—

THAT Report No. 2 of the Education Committee (in Committee) (Meeting held on the 19th September, 1939—Agenda, pages 1039-1040) be received.

AMENDMENT moved by Councillor Curton, seconded by Alderman Richardson:—

THAT Report No. 2 of the Education Committee be received with the exception of the last five lines of item 2 on page 1040.

The amendment, on submission, was declared **carried**.

369.—Accordingly RESOLVED—That Report No. 2 of the Education Committee (in Committee) (Meeting held on the 19th September, 1939—Agenda, pages 1039-1040), with the exception of the last five lines of item 2, on page 1040, be received.

ADOPTION OF REPORT:

370.—RESOLVED—That Report No. 2 of the Education Committee, in so far as it relates to matters requiring the confirmation of the Council, be approved and adopted *as amended*.

REPORT NO. 3.

Moved by Alderman Copestake, seconded by Councillor Scott, and

371.—RESOLVED—That Report No. 3 of the Education Committee (Meeting held on the 3rd October, 1939—Agenda, pages 1041-1046) be received.

ADOPTION OF REPORT:

372.—RESOLVED—That Report No. 3 of the Education Committee in so far as it relates to matters requiring the confirmation of the Council, be approved and adopted.

EMERGENCY (LOCAL GOVERNMENT) COMMITTEE (FINANCE AND GENERAL PURPOSES COMMITTEE):

Moved by Alderman Clemens, seconded by Councillor Collins, and

373.—RESOLVED—That the report of the Emergency (Local Government) Committee (Finance and General Purposes Committee) (Meeting held on the 2nd October, 1939—Agenda, pages 1047-1079) be received.

Page 1053—Item 26—War Time Adult Educational Facilities.

On consideration of the above item the Chief Librarian reported that in view of the poor attendance at lectures to adults hitherto held at the Branch Libraries it was extremely doubtful whether those suggested by the Ministry of Information would get sufficient support to justify their arrangement. A series held at the Central Library might be more successful if the lecture room were available, but no lectures were possible as long as the room was in use for storage purposes.

Noted.

Page 1055—Item 35—Repair of War Damage—Housing Accommodation Ministry of Health Circular No. 1810.

In connection with the above item the Town Clerk submitted the following report:—

The Housing (Emergency Powers) Act, 1939.

The object of this Act is to ensure that in spite of war damage a reasonable amount of habitable accommodation shall remain available in any district.

For this purpose local authorities are empowered to carry out

- (1) "First Aid" repairs without notice.
- (2) More permanent repairs after serving—with the consent of the Ministry of Health—fourteen days' notice.

[The representative of the Minister will bear in mind the value of the property repaired and the cost of the repairs.]

Local Authorities must consider representations from persons having control of the houses, but there is no appeal against their decision.

The cost of repairs would be a charge on the property but recovery would be postponed till the end of the emergency.

Claims for war damage must be lodged with the local office of the Inland Revenue Valuer within 30 days of the damage being done, and it is understood that compensation will be paid at the end of the war, in accordance with a scale which will then be drawn up.

Having regard to the foregoing and bearing in mind the object of this recent legislation, there is little likelihood of obtaining any further safeguards.

After discussion it was agreed that the Council should make representations to the Minister of Health with a view to the owners of premises damaged by war action being adequately safeguarded in respect of the extent of the repairs they will be required to carry out to such premises, the procedure for carrying out such repairs, and the recovery of the cost thereof. It was further agreed that other local authorities be asked to support the Council's representations.

Page 1072—Item 84—Health Centre, North of Edgware Way.

It was agreed that the second paragraph of the above item be amended by the deletion of the word "matter" in the last line, and the substitution thereof of the words "provision of a Clinic."

*Page 1078—Item 118—Education Committee—
Resignation of Mrs. S. J. Bannister.*

On the motion of the Mayor, which was seconded by Alderman Reynolds, it was

- 374.—RESOLVED—**That the resignation of Mrs. S. J. Bannister, L.L.A., as a Co-opted Member of the Education Committee be accepted with regret; that the Town Council do accord to Mrs. Bannister their sincere thanks for the valuable work she has rendered as a Member of the Education Committee, and indicate their desire that when happier conditions prevail she should renew her association with the work of the Committee.**

Page 1078/9—Item 120—Local Government—War-time Organisation of Committees.

Discussion ensued on consideration of the scheme set out in the above item for the carrying out of local government business after the 9th November, 1939, and the Scheme was **approved** on the understanding that each separate Committee comprised in the two groups should elect its own Chairman.

ADOPTION OF REPORT: Moved by Alderman Clemens, seconded by Alderman Copestake, and

- 375.—RESOLVED—**That the report of the Committee, as amended, be approved and adopted.**

EMERGENCY COMMITTEE:

The following report was submitted:—

REPORT OF EMERGENCY COMMITTEE to the MEETING of the BOROUGH COUNCIL.

9th October, 1939.

To the Mayor, Aldermen and Councillors
of the Borough of Hendon.

Ladies and Gentlemen,

Introduction.

In our first report submitted to the Council on the 18th September, we endeavoured to place before you a brief indication of the position of the various Services for Civil Defence within the Borough.

In view of the short time which has elapsed this report is merely intended to submit for your information a record of the present position in certain matters and the more important decisions which have been taken.

1.—WARDENS' ORGANISATION:

(A).

Paid Personnel.

The Controller reported the receipt of a letter from the County Air Raid Precautions Officer, dated the 25th September (confirming the information given on the 22nd), to the effect that the Home Office would not approve for grant the payment of more than 20 per cent. of the war establishment of Wardens. The establishment shown in the communication indicated:—

1536 men.

384 women.

1920 -- 20 per cent. = 384

Since the above establishment was approved the whole of the Service has been re-arranged on the present Districts and Posts, and the total complement required is now 2,051, exclusive of reserves,

1633 men,	
412 women,	

2051	— 20 per cent. = 410

The limitation of 20 per cent presents some difficulty in maintaining an efficient Service, especially for the purpose of day patrols, and in the opinion of the Controller a minimum of 650 full-time paid personnel is desirable.

The Committee have interviewed the Chief Warden and the Deputy Chief Warden regarding the action taken to reduce the number of paid personnel necessitated by the decision of the Home Office referred to above. It is understood that the general principles followed in the matter were on the following lines:—

Wardens in other employment were first taken off.

All over 60 years of age were then eliminated unless any special reasons existed.

To the remainder individual consideration was given in relation to efficiency and all things being equal financial circumstances were then taken into account and preference given as far as possible to Ex-Service men.

The Committee indicated their approval to the lines adopted and (25/9/39) had before them a statement showing the day-time patrol strength of the various Wardens' Posts. Upon consideration of the deficiencies in numbers and the difficulty of maintaining an effective voluntary Service, the Committee came to the conclusion that an increase in the approved percentage (20 per cent.) of paid Wardens would be necessary to meet the situation. It was thereupon decided that a deputation consisting of His Worship the Mayor, the Chairman of the Committee (Councillor E. Arter), Councillor A. W. Curton, the Controller and the Acting Chief Warden be appointed to confer with the Commissioner of Police with a view to obtaining consent to an establishment of 666 Wardens as paid personnel for the Service. (26/9/39).

In trying to arrange for the deputation to be received, the Controller was informed that no useful purpose would be served by the attendance of the deputation and an intimation was given that probably a further reduction in the personnel would be made.

The Committee are in communication with the Commissioner of Police through the Town Clerk on the matter. (28/9/39).

(B).

Record of Duties.

The Committee have directed that arrangements be made for all Wardens (paid and voluntary personnel) on reporting to their Posts for duty to sign (in a book to be provided) the time of arrival for duty, enter in such book a record of the duties performed and to record the time at which the period of duty ceased. (16/9/39).

2.—CASUALTY SERVICES:

(A).

Ambulances.

The Council (18/9/39) passed the following resolution:—

“That in the opinion of the Council the Emergency Committee should proceed forthwith, irrespective of the consent of the Middlesex County Council, with the provision of an adequate and efficient fleet of 35 additional ambulances at an estimated cost not exceeding £2,500 as contemplated by item 6 (iii) of their report.”

In pursuance thereof the Committee resolved (19/9/39):—

“That the Ambulance Officer (Councillor A. W. Greville) be authorised to proceed immediately with the purchases of the required vehicles and to arrange, in consultation with the Borough Surveyor, for conversion and adaptation of such vehicles, within the estimated cost of £2,500.”

Due provision is being made under this decision, and it is anticipated that the full fleet of 35 ambulances will be available in the Borough within the next fortnight. The original complement was 78 and an enquiry has been addressed to the County Council on the question of proceeding to make satisfactory provision up to this number.

(3/10/39).

We continue to press for recognition to the expenditure, and it is understood that the application is now receiving careful consideration by the Ministry of Health and the Home Office. The Council will be interested to learn that certain of the ambulances provided under this Scheme have been inspected by Admiral Sir Edward Evans, K.C.B., D.S.O., one of the London Civil Defence Commissioners, who has written:—

“I feel that London Region should have hundreds of these instead of the lorries and even pantechinon vans, which have been used in some boroughs.

You may hear from the ... County Council in connection with your splendid work; which is, I think, most helpful to London Civil Defence.” (3/10/39).

(B). *Cars for Stretcher Parties and Sitting Wounded.*

The present Scheme for the transport of Stretcher Parties and Sitting Wounded is that certain personnel both paid and voluntary are providing cars for these parties. This method is very unsatisfactory, in so far as it depends on personnel continuing to supply cars, which for the most part are unsuitable from the point of view of size and type. Furthermore, the number of cars available is dependent on the regular attendance to duty of the personnel owning them.

The position regarding the use of these private cars has become more acute because of the following factors:—

1. All male personnel employed at Ambulance Depôts are paid a flat rate of £3 per week, those supplying cars are now demanding extra payment for their use.
2. A fresh taxation period is imminent and the owners are requesting that the Council should pay the next instalment otherwise those requiring tax renewal will be withdrawn from service.
3. Most owners are now requesting that the Council contribute to the car insurance.
4. Further difficulties are arising owing to the new petrol regulations. Most of the present owners are now demanding free supplies of petrol for their journeys to and from duty.

The above difficulties will increase as more transport is required.

Three Schemes for car transport have been investigated:—

Scheme 1—Dependent upon personnel appointed providing own cars of suitable size and power.

Scheme 2—Based upon the purchase of cars by the Committee.

Scheme 3—Based upon cars being requisitioned at the rate of say 30/- per week or £78 per annum for each car.

The comparison in the costs involved under the various Schemes is as follows:—

Scheme.	1st year.	2nd year.	3rd year.	Total.
1	£20,694	£20,694	£20,694	£62,082
2	£ 5,830	£ 1,590	£ 1,590	£ 9,010
3	£ 8,268	£ 8,268	£ 8,268	£24,804

Your Committee deemed it necessary in order to secure an efficient Service to make application for the approval of the Scheme Making Authority to the following Scheme:—

Scheme 2.

Based upon purchase of cars by Local Authority.

According to war strength the number of cars required under this Scheme would be:—

52 cars for Stretcher Parties.

52 cars for Sitting Wounded.

2 cars for Mobile Unit personnel.

Total 106

Assuming that cars of 12 h.p. or more can be purchased at the cost of £40 each, the cost of 106 cars would be as follows:—

Cost of cars at £40 per car	—	—	—	—	—	£
Taxation and Insurance	—	—	—	—	—	Nil
Maintenance at £15 per car	—	—	—	—	—	1,590
Total	—	—	—	—	—	£5,830

Cost of Scheme 2 for first year £5,830.

Cost for subsequent years, i.e., maintenance only (£15 per car x 106) £1,590.

[There would also be a certain realisation value of cars at the end of the war.]

It is understood that the application is being considered by the Ministry of Health and Home Office, but a verbal intimation has been received from the County Council that if the Borough Council care to take the risk we can proceed to purchase at reasonable prices pending the issue of the sanction.

In view of the urgency in the matter we have authorised in the first instance the purchase of 52 cars. (3/10/39).

3.—ASSISTANT MEDICAL OFFICER OF HEALTH:

Pursuant to the Committee's Minute (4/9/39—5), the Chairman, in consultation with the Chairman of the Public Health Committee and the Medical Officer, appointed Dr. J. N. Morris as temporary full-time Assistant Medical Officer. (26/9/39).

4.—MULTI-PURPOSE BUILDINGS AND TWO FIRST AID POSTS:

Directions have been given for tenders to be obtained on a fixed schedule of prices for materials and current rates for labour for the erection of 3 Multi-Purpose Buildings at—

Claremont Road
Hendon Grove
Mill Hill Park (Daws Lane)

and for two First Aid Posts at—

Hendon Cottage Hospital
 Hendon Isolation Hospital. (19/9/39).

In the negotiation with the Managers of the Hendon Cottage Hospital for the lease of the land required, insuperable difficulties have been found which indicated the improbability of agreement and the desirability of exploring the possibility of finding a new site.

The Committee regret to note that difficulties should have arisen with the Managers in arriving at satisfactory terms for the lease, especially having regard to the urgent necessity for the provision of the First Aid Post in the existing emergency, and have directed that the Managers of the Hendon Cottage Hospital be so informed. (26/9/39).

The question of an alternative site for the First Aid Post in substitution for that intended at the Cottage Hospital is receiving attention.

5.—DEPOTS—SLEEPING ACCOMMODATION AND HEATING:

The Committee have conferred with the Borough Surveyor on the question of the accommodation at various Depôts in relation to their suitability for sleeping during winter months, and have considered details as to the number of parties and their constitution.

It was apparent that additional accommodation was essential at Mill Hill and West Hendon Swimming Pools, and in view of the cold weather approaching and the labour available, one large hut has been erected at Mill Hill and another is being constructed at West Hendon by direct labour.

In addition, tenders have been considered for a further hut at each of the Swimming Pools, and the consent of the Scheme Making Authority is being sought to the acceptance of tenders (based upon the supply of timber from stock at Hendon Way Depôt).

Mill Hill	£420
West Hendon	£285. (3/10/39).

6.—DEPOT PARTIES—RECREATIONAL FACILITIES:

The Controller reported the receipt of applications for recreational facilities to counteract the long periods of inactivity. In this connection the London Regional Circular No. 50 was submitted in which it was stated:—

Parties are settling down as well as can reasonably be expected, but a great number of A.R.P. workers are beginning to feel the strain of having nothing to do. In fact, they are getting bored. The cure for this is activity, and for this reason, apart from the vital necessity of taking advantage of the present respite to perfect the organisation of the Services, we request that you will carry out exercises within your Borough as soon and as frequently as may be found possible.

These exercises should provide valuable training for personnel, especially those recently recruited, besides making them acquainted with the geography and special features of their locality.

For the time being many members of the Civil Defence Services are being engaged on sandbagging of buildings and other work connected with their Depôts, but this work will be of limited duration and if the present period of quiet is prolonged the exercises referred to above will be insufficient to occupy their time. The

Commissioners therefore recommend most strongly that Local Authorities should take immediate steps to encourage the development of organised physical training, games and recreation for the personnel. There will almost certainly be found in the ranks of the A.R.P. workers, persons with experience and ability in this matter whose services could usefully be enlisted for this purpose."

The Controller has been directed to make early arrangement for adequate and frequent exercise on the lines contemplated by the London Regional Circular No. 50, and to report on the results of the exercises carried out. (14/9/39).

The Committee have considered a report on the requisites required for recreation games, etc., with an estimate of cost and information as to the Depôts and Posts concerned and have submitted an application to the County Council for consent to an estimated expenditure of £17 15s. 2d. (25/9/39).

7.—SHELTERS (INCLUDING TRENCHES):

This matter has received special attention during the last fortnight.

The Chairman reported that application had been received from the Press for information as to the authorised provision and intended user of Public Shelters and the population of the Borough on which the provision of such accommodation had been based.

Generally the provision is based on an estimated population of 170,000, and the authorised provision of Shelters is for 10 per cent. of the population in mainly residential areas and about 15 per cent. of the day population in business centres — **the Shelters being intended for persons caught in the streets and for persons within the scheme of free provision of Shelters for whom Shelters cannot be provided at their homes.**

The authorised scale had been carefully considered when the original programme was prepared, and it had been found more advantageous to base the provision on 10 per cent. of the total population. With this in view it was at that time proposed to provide:—

				Accommodation. (Persons).
First Scheme of Trenches built by direct labour	—	—	—	3,400
Shelters consisting of empty shops, etc.	—	—	—	1,500
Second Scheme of Trenches to be built by contract	—	—	—	12,100
				17,000
			Total	17,000

On the war emergency occurring it soon became evident that difficulties would arise in connection with materials for the construction of Trenches. The Surface Shelters were, therefore, pushed on with and increased in number, the present position being as follows:—

				Accommodation. (Persons).
First Scheme of Trenches completed	—	—	—	3,400
Shelters, consisting of empty shops, etc.	—	—	—	5,000
			Total	8,400

With regard to the second Scheme of Trenches the contract was let to Rigg and Remington Ltd. for the balance to accommodate 12,100. Steel linings were promised by Steel Ceilings, Ltd., for the 15th September, but they subsequently altered this date to the 1st October. No useful purpose would, therefore, have been served in opening up more ground until a supply of linings was assured.

In the circumstances the instructions to this firm were limited to the following blocks of Trench Shelters:—

	Persons.
Clitterhouse Playing Fields	850
West Hendon Playing Fields	450
Colindale Park	300
Watling Park	800
Montrose Playing Fields	550
Total	<u>2,950</u>

On the completion of the above Trenches the provision would therefore be as follows:—

	Accommodation. (Persons).
First Scheme—Trenches	3,400
Shelters consisting of empty shops, etc.	5,000
Second Scheme—Trenches	2,950
	<u>11,350</u>

leaving provision to be made for 5,650 to bring the total up to 10 per cent. of the estimated population (i.e., 17,000).

The Committee have carefully considered the possibility of obtaining the services of a number of firms working on a cost plus percentage basis to provide Trenches up to the authorised accommodation, but having regard to the fact that the speed of the contractors would be controlled by the delivery of materials on which there is little or no guarantee, they are of opinion that the inevitable delay in completion must be avoided by the adoption of other methods to provide protection.

Before departing from the intention to proceed with the Trenches, the Committee considered the possibility of alternative forms of construction, but a satisfactory variation of the specification to meet the approval of the Home Office presents considerable difficulty.

A similar problem is being faced in other areas, and one solution appears to be the construction of Surface Shelters in units for about 100 persons. The Borough Surveyor submitted designs of a proposed Surface Shelter to accommodate 100 persons, and it is understood that the design would be approved by the Home Office and any expenditure incurred would rank for grant. Authority has been given for the construction of 24 Surface Shelters.

Since this decision was taken, circumstances in regard to the supply of steel have improved, and the full programme of Public Shelter accommodation contemplated by the Committee, at this date, is:—

1st Scheme—Trenches	3,400
2nd Scheme—Trenches	2,950
Shelters, empty shops, etc.	5,000
24 Surface Shelters (to be erected)	2,400
Trenches (to be constructed)	3,250
	<u>17,000</u>

(26/9/39).

The question of siting of some of the Public Shelters has been raised by the County Council, and the Borough Surveyor has made representations on the matter. In the meantime, of course, further progress towards the completion of the Scheme outlined above is to some extent delayed pending a decision from the Scheme Making Authority.

8.—PETROL SUPPLIES:

The Borough Surveyor reported upon a Scheme for securing and controlling supplies of petrol for all Services for which the Council are normally responsible or have assumed by reason of the present state of emergency.

Petrol rationing came into operation on the 23rd September, and quantities which the Council are authorised to purchase for the various Services are based on an estimate sent to the Petroleum Office of the Mines Department some months ago. The supplies will be arranged and maintained by the Local Manager of the Petroleum Board on the orders of the Borough Surveyor.

The Scheme provides for taking over three pumps and tanks (one at each of the following):—

North—Observatory Garage, Watford Way, N.W. 7.

Central—Hill's Garage, Finchley Lane, N.W. 4.

South—Metropolitan Motors, St. Albans Lane, N.W. 11.

The Council's pumps at the Central Dépôt, Hendon Way, and the Refuse Disposal Works, North Circular Road, also to be available.

Before any vehicle in private ownership is supplied with petrol, the Borough Surveyor must issue a certificate that such car is permitted to be engaged on Council Services and entitled to a supply of petrol either free, or at cost of the owner.

Supplies for all Services will be obtained on a written authority (stores issue note) from the nearest pump mentioned above, and arrangements made for pump owner to make weekly returns of petrol issues. The contents of the tank are to be checked periodically by the Borough Surveyor in order to check the Council's stock.

As regards the issue of permits for supplies, the stores issue notes are to be signed by:—

- (a) the 8 Dépôt Commanders in respect of petrol necessary for Air Raid Precautions Services at their respective Dépôts;
- (b) the Fire Superintendent in respect of supplies for the Fire Brigade and the Auxiliary Fire Service; and
- (c) the Borough Surveyor, or such other persons as may be authorised by him, in respect of petrol necessary for any other purpose appertaining to the Council's Services.

The persons authorised to sign the stores issue notes are to be responsible for ascertaining that the quantity issued is reasonable having regard to the Service rendered, and they will also keep a record of all petrol issued to each vehicle, together with a return of the mileage on the Council's Services, such records to be in a form to be approved by the Borough Treasurer and the Borough Surveyor.

The Scheme has been approved, and any disputes in its administration will be referred to the Emergency Committee. (14/9/39).

9.—CIVILIAN DEATHS:

The Controller has received a letter from the Ministry of Health intimating that arrangements are being made to earmark premises for Mortuary purposes, viz., Highfield Garage, Hills Garage and Nelsons Club, and that on receipt of an estimate of the cost of the equipment proposed to be obtained the Minister will be prepared to issue his approval for grant purposes.

It will be appreciated that the earmarking of the premises mentioned is merely a temporary expedient against any emergency, and for a long term policy we propose to consider plans in course of preparation for three buildings of temporary structure (11/9/39—6) which will eventually replace the premises proposed to be earmarked.

In the circumstances the Controller has been directed to arrange for the provisional earmarking only of the three premises referred to in the Scheme, and to inform the Ministry of Health of the proposal for the erection of three temporary buildings.

(25/9/39).

The personnel for the three Mortuaries has been arranged, and authority has been given for the Senior Attendant at each to be paid at the rate of £3 per week, and for the remaining Attendants to be retained on call at a fee of 10/- per week each, subject to such Attendants entering into a form of undertaking to be approved by the Town Clerk. (26/9/39).

10.—CONTROLLER'S SALARY:

In connection with the decision (12/9/39—8) taken to increase the salary of the Controller to £800, rising by six monthly increments of £50 to a maximum of £900—such scale to be applicable for a period of twelve months or to the conclusion of hostilities whichever is the earlier—we have made representations to the Scheme Making Authority to obtain recognition of the increase for the purposes of grant but they have decided to adhere to their decision given in the following terms:—

“..... regarding the increase in salary which your Council propose to pay to your Air Raid Precautions Officer who is now the Controller in your Borough, I have to inform you that the question was discussed at the last meeting of my War-time Emergency Committee who feel that they are only able to approve the sum of £600 per annum ranking for grant, in accordance with the scale of salaries set out in my circular letter of the 6th instant.” (19/9/39).

11.—DISCIPLINE—A.R.P. PERSONNEL:

The Heads of Services have been authorised, after full investigation and satisfaction in respect of any irregularity of conduct, to take such disciplinary action as they deem desirable, including the dismissal of any persons (other than permanent staff of the Council) engaged on the Civil Defence Services. (14/9/39).

12.—ACCOMMODATION ROAD—CENTRAL FIRE STATION:

In order to provide better facilities for the movement of traffic at the Fire Station and Town Hall, the Borough Surveyor has been authorised to extend the existing accommodation road on the south side of the Central Fire Station. (14/9/39).

13.—STAFF SHELTERS—HENDON GROVE:

The Committee have again discussed the question of the intended user of these Trenches (Town Hall Staff or Public), and after receiving reports from Chief Officers reaffirmed the previous decision allocating the Trenches for the use of the Town Hall Staff (A.R.P.C., 16/5/39—7 (1); Emg.C., 4/9/39, 16/9/39 and 19/9/39).

The Borough Surveyor has been requested to consider the question of the necessity for further public accommodation in this area.

14.—LECTURE FEES—PERMANENT STAFF:

At the request of the Committee, the Borough Treasurer reported on the provisions of Air Raid Precautions Department Circular No. 51 of the 17th March last in which the following paragraph appears:—

"The fees are subject to the conditions set out in paragraph 11 of the explanatory memorandum issued with Home Office Circular 701.078/10 of the 29th July, 1938, on the Air Raid Precautions (Approval of Expenditure) Provisional Regulations, 1938. The phrase 'reasonable maximum limit' in that paragraph may be interpreted to mean payments in respect of not more than five lessons a week."

Approval has been given for members of the permanent staff to be engaged as Lecturers up to a maximum of five lessons per week. (25/9/39).

15.—CIVIL DEFENCE SERVICES—GENERALLY:

The Committee were called into consultation, at an informal meeting on the 27th September, with the County Emergency Committee when various references were made to the Civil Defence Services of the Borough. Subsequently a report was received from the Controller, Group 6, on a visit of one of his Officers to the several Depôts on the 1st October.

Your Committee have very carefully considered all matters which came under discussion at the meeting, and such as are mentioned in the report, together with the observations of the Chief Officers concerned and the Controller for the Borough. We, and the Heads of Services, are equally aware of the difficulties which exist in the working of the present "short term" policy in improvised buildings and other premises, but every endeavour has been made and continues to be made to ensure an effective Service under present conditions.

(Signed) E. ARTER.

A. W. CURTON.

C. PINKNEY.

6th October, 1939.

Item 15—Civil Defence Services Generally.

Debate ensued on consideration of the above item.

Motion moved by Councillor Pugh, seconded by Alderman Richardson:—

THAT the report received from the Controller, Group 6, on a visit of one of his officers to the several Depôts on the 1st October, be made available to the Council this evening.

After discussion the motion was **withdrawn** on the understanding that a copy of the report and of the Emergency Committee's reply thereto would be circulated to each member of the Council.

ATTENDANCE OF MEMBERS OF THE COUNCIL AT MEETINGS OF THE EMERGENCY COMMITTEE:

Motion moved by Councillor Bridge, seconded by Alderman Richardson:—

THAT Members of the Council who so desire shall be entitled to attend any meeting of the Emergency Committee, but such members shall not be entitled to take part in the proceedings without the consent of the Chairman of the Meeting, nor in any case to vote.

On submission, the motion was declared **carried**.

376.—Accordingly **RESOLVED**—That Members of the Council, who so desire, shall be entitled to attend any meeting of the Emergency Committee, but such Members shall not be entitled to take part in the proceedings without the consent of the Chairman of the Meeting; nor in any case to vote.

SEALING OF DOCUMENTS:

Moved by Councillor Naar, seconded by Councillor Hirschfield, and

377.—RESOLVED—That the Corporate Seal be affixed to the following documents:—

Power of Attorney	To authorise the receipt of monies due to the Corporation in an action—The Corporation v. Bowen.
Mortgage	The Corporation and the Trustees of the Boilermakers Iron and Steel Shipbuilders Society—to secure loan of £10,000 and interest.
Indemnity	To Barclays Bank Limited relating to the release of deposited monies in respect of road charges on land in Marion Road, Mill Hill.

VOTE OF THANKS TO THE MAYOR:

Moved by Alderman Clemens, seconded by Councillor Hicks, and

378.—RESOLVED—That this Council, on behalf of the inhabitants of Hendon, place on record its high appreciation and thanks for the valuable service rendered to the District by His Worship the Mayor (Councillor Herbert George Potter, J.P.) over a continuous period of 13 years, and in particular during the year of his Mayoralty for his able conduct of the business of the Corporation. They further convey to the Mayoress their sincere thanks for the support which she has at all times accorded to His Worship the Mayor and for her unflinching interest in the welfare of the Borough.

379.—FURTHER RESOLVED—That the foregoing resolution be engrossed on vellum with the Corporate Seal affixed thereto and presented to the Mayor.

His Worship the Mayor, on behalf of the Mayoress and himself, thanked the Council for the sentiments embodied in the foregoing resolutions.

RECESS POWERS:

Moved by the Deputy Mayor (Alderman Egan) seconded by Alderman Clemens, and

380.—RESOLVED—That His Worship the Mayor, or in his absence the Deputy Mayor, be vested with power to deal with all urgent matters which may arise during the interim to the 9th November, 1939.

The Meeting terminated at 9.21 p.m.

A. A. Naar
Mayor.

B O R O U G H O F H E N D O N

NOTICE IS HEREBY GIVEN

THAT A SPECIAL MEETING of the Council of the Borough of Hendon in the County of Middlesex, will be held on MONDAY next, the 6th day of NOVEMBER, 1939 at 6 o'clock in the afternoon, at the Town Hall, The Burroughs, Hendon, N.W.4. and all and several the Members of the said Council are hereby summoned to attend.

1. Official Announcements.
2. Questions.
3. To consider reports of Special Committees appointed by His Worship the Mayor during Recess.

Town Clerk.

Town Clerk's Office,
Hendon, N.W.4.

1st November, 1939.

S
T
I
S
P
O
P
O
N
M
T
K
J
H
G
F
E
D
C
B
A



Minutes.

At a Special Meeting of the COUNCIL of the BOROUGH OF HENDON, held at the Town Hall, The Burroughs, Hendon, N.W. 4 on Monday, the 6th day of November, 1939, at 6 o'clock p.m.

PRESENT:

His Worship the Mayor (Councillor H. G. Potter, J.P., F.S.I.), in the Chair.

The Deputy Mayor (Alderman S. H. Egan, J.P.).

Aldermen:

**J. J. Copestake, J.P.,
W. M. Maughan, J.P.,**

**A. J. Reynolds, J.P.,
C. R. Richardson,**

R. A. B. Teare, M.B.E.

Councillors:

**E. Arter, M.C., M.I.A.E.,
F. H. Bate,
T. K. Bridge,
F. J. Collins,
H. Connell, J.P.,
E. J. Cox,
A. W. Curton,
A. W. Grevilla,
J. Griffiths,**

**W. A. Hicks,
G. H. Hignett,
L. Hirshfield,
P. Lightfoot,
A. A. Naar, M.B.E.,
(Mrs.) F. E. Parvin,
C. Pinkney,
C. J. Pryke, F.I.A.C.,
A.M.I.S.E.,**

**T. Pugh,
T. J. Scott,
W. H. N. Shakespeare,
M.C., A.F.C., J.P.,
H. P. Small,
(Mrs.) M. Thomas,
C. F. Windust.**

NOTICE OF MEETING:

The Town Clerk read the notice convening the Meeting.

OFFICIAL ANNOUNCEMENTS:

The Town Clerk read a letter from Alderman F. C. Rice explaining the reason for his absence from the meeting.

SPECIAL COMMITTEES:

His Worship the Mayor made the following announcement:—

On the expressed wish of the Members of the Council for the appointment of two Special Committees, the following were constituted with the terms of reference indicated:—

(i) **Special (A.R.P.—Inquiry) Committee:**

Consisting of

Members.

Alderman W. M. Maughan.
" G. R. Richardson.
" R. A. B. Teare.
Councillor T. K. Bridge.
" G. J. Pryke.
" T. J. Scott.

Terms of Reference.

"To investigate the administration and control of the Air Raid Precautions Organisation and to report back to a further meeting of the Council to be held before the 9th November next upon—

1. The efficiency of the Controller.
2. The degree of assistance received or expected by him from the permanent Officials.
3. To what extent the Emergency Committee could have controlled any defects that may have arisen out of numbers 1 and 2.
4. A general investigation into the reports now before the Council and report thereon."

(ii) **Special (Fire Brigade—Inquiry) Committee:**

Consisting of

Members.

Councillor F. J. Cox.
 „ G. H. Hignett.
 „ T. Pugh.
 „ W. H. N. Shakespeare.
 „ C. F. Windust.

Terms of Reference.

“To enquire into the general condition of the Fire Brigade Service in the Borough.”

QUESTIONS:

Air Raid Precautions.

Pursuant to notice duly given in accordance with Standing Order No. 22, Councillor Bridge asked the Chairman of the Emergency Committee the following questions:—

1. *What, in approximate terms, is the capital expenditure on Air Raid Precautions since its inception to October 31st?*
2. *Of the above figure*
 - (a) *What amount ranks for grant?*
 - (b) *What amount is to be met by the Hendon Borough Council?*
3. *What is the total expenditure on salaries and wages for all personnel from the commencement of the war, September 3rd, to the end of October?*
4. *Of the above figure*
 - (a) *How much has been paid to regular A.R.P. personnel?*
 - (b) *What is the cost of salaries and wages of regular Council staff seconded to A.R.P. work?*
5. *What is the total number of A.R.P. personnel paid by the Hendon Borough Council during the last complete week of October, 1939?*

Reply by Chairman of the Emergency Committee (Councillor Arter):—

1. The approximate Capital Expenditure to which the Corporation became committed since the inception of A.R.P. up to the 31st October, 1939, is £204,771. As much of the work is still in progress, certain items are based on estimates.
2. (a) The amount thereof recoverable by way of Grants from Government Departments and by reimbursement from the Scheme Making Authority is approximately £173,191.
 (b) The amount to be met by the Corporation is approximately £31,580.
 (a) and (b) are subject to final audited costs.
3. The total expenditure on salaries and wages for all personnel from the commencement of war to the end of October is £48,153.

4. (a) Of the above figure the amount paid to whole-time personnel was £43,308.
 (b) The amount paid to staff (administrative) engaged and seconded for A.R.P. duties was £2,845.
 (c) The amount paid to Corporation workmen, painting kerbs and generally, was £2,000.
5. Total number of A.R.P. personnel paid by the Corporation during the last complete week of October, 1939 (excluding Council's workmen):—

Staff (Administrative)	74
Auxiliary Fire Service	276
Air Raid Wardens	872
Other A.R.P. Services	1048
Total	1770

REPORT OF SPECIAL (AIR RAID PRECAUTIONS—INQUIRY) COMMITTEE:

Motion moved by Alderman Teare, seconded by Alderman Maughan, and
 381.—RESOLVED—That the following report be received:—

REPORT OF THE SPECIAL (AIR RAID PRECAUTIONS—INQUIRY) COMMITTEE.

1.—APPOINTMENT OF COMMITTEE:

This Committee was appointed by His Worship the Mayor in Recess to meet the wishes of the Members of the Council expressed at an informal meeting held on the 25th October, 1939.

2.—CONSTITUTION:

Aldermen:—

W. M. Maughan, J.P.
 G. R. Richardson.
 R. A. B. Teare, M.B.E.

Councillors:—

T. K. Bridge.
 G. J. Pryke, F.I.A.C., A.M.I.S.E.
 T. J. Scott.

3.—TERMS OF REFERENCE:

“To investigate the administration and control of the Air Raid Precautions Organisation and to report back to a further meeting of the Council to be held before the 9th November next upon—

1. The efficiency of the Controller.
2. The degree of assistance received or expected by him from the permanent officials.
3. To what extent the Emergency Committee could have controlled any defects that may have arisen out of numbers 1 and 2.
4. A general investigation into the reports now before the Council and report thereon.”

4.—CHAIRMAN:

Alderman R. A. B. Teare, M.B.E., was appointed Chairman of the Committee.

5.—MEETINGS OF COMMITTEE:

Thursday, 26th October, 1939.

The Committee commenced their investigation and inspected the Golders Hill House First Aid Post and Ambulance and Stretcher Party Depôt.

Friday, 27th October, 1939.

The Committee interviewed the Officer who was in charge of the West Hendon Depôt at the time of Capt. Matheson's inspection of the 1st October; the Borough Engineer and Mr. Pelham; and the Medical Officer and Dr. Livingstone. They also inspected the following:—

1. Clitterhouse Farm—Ambulance and Stretcher Party Depôt.
2. West Hendon First Aid Post.
3. West Hendon Swimming Pool—Combined Depôt.

Saturday, 28th October, 1939.

An inspection was carried out at—

1. Hendon Way Reseue, Decontamination and Repair Depôt.
2. Mill Hill Swimming Pool:—
 - (a) Sub Report Centre;
 - (b) Combined Depôt.
3. Mill Hill—Hartley Avenue—First Aid Post.
4. Mobile First Aid Unit.

Sunday, 29th October, 1939.

The following services were inspected:—

1. Central Hendon First Aid Post.
2. Hendon County School—Ambulance and Stretcher Party Depôt.
3. Christ Church Hall (The Crest)—Rest quarters for Nursing A.R.P. Personnel.
4. John Groom's Crippleage—Ambulance and Stretcher Party Depôt.
5. Redhill County Hospital—Ambulance and Stretcher Party Depôt.
6. West Hendon—York Park Shelters.
7. Colindale Hospital First Aid Post.
8. Hyde School—Trenches in course of construction.
9. Hendon Isolation Hospital—Casualty Clearing Station.
10. Wardens' Posts—one temporary, one permanent.

Monday, 30th October, 1939.

The Committee inspected the A.R.P. Headquarters at "Ravensfield" and subsequently interviewed the Controller (Captain E. C. Smith), the Medical Officer of Health and the Borough Engineer.

Tuesday, 31st October, 1939.

An inspection was made of the Main Control and Report Centre at Hendon Technical Institute and the members of the Emergency Committee were also interviewed.

Wednesday, 1st November, 1939.

The members of the Emergency Committee again attended before the Committee.

Thursday, 2nd November, 1939.

We interviewed the Chief Warden (Captain Petrie); gave consideration to various outstanding matters and proceeded with the completion of our report.

6.—CRITICISMS AND OBSERVATIONS:

The criticisms and observations we have to make as a result of our visits of inspection and the consideration of the reports referred to in our terms of reference are appended.

PART I.
SERVICES INSPECTED BY CAPTAIN MATHESON.

CRITICISMS.	COMMENDATIONS.
<p>1. Golders Hill House—First Aid Post and Ambulance and Stretcher Party Depôt:</p> <p>(a) First Aid Post:</p> <p>(i) With regard to paragraph 2 of item 1 of Capt. Matheson's report we find that the provision of chairs in the rest room is satisfactory for rest purposes for the staff, but are of opinion that instead of the kitchen being used as a rest room for nurses, the large room should be used for rest purposes for the sisters and nurses.</p> <p>(ii) On the occasion of our visit some considerable time elapsed before we were able to get into touch with the Sister-in-Charge.</p> <p>(b) Cleansing Section:</p> <p>(i) The cleansing arrangements in the decontamination section are unsatisfactory and a corridor should be provided to enable contaminated persons to pass into the "shower" room without coming into contact with persons who have been cleansed.</p> <p>(ii) Locks should be provided to the outside doors of the cleansing section so that the cleansing utensils can be left in the rooms in which they are intended to be used.</p> <p>(iii) Steps should be taken to provide adequate ventilation for the building during the "black-out" periods.</p>	

CRITICISMS.

COMMENDATIONS.

(iv) **Equipment Room.**—We are satisfied as a result of our inspection that it is possible to improve on the housing of the protective clothing and steps should be taken to effect such improvement.

(v) The depot generally was not kept in as tidy a condition as it might be and the general appearance of the interior of the depot could be smartened up.

(c) Lay-out of building:

We are in agreement with the remarks in Capt. Matheson's report to the effect that the lay-out of the building is unsatisfactory, but we are of opinion that the only solution is the erection of a new building.

(d) General conclusion:

We are of opinion that an improvement in the accommodation at this depot must be made and suggest that preferably a building should be erected to accommodate the First Aid Post, provided its erection can be arranged in the grounds of the Manor House Hospital or in close proximity thereto, e.g.—at Annandale House, North End Road.

If this does not prove to be practicable the alternative would appear to be the removal of the Ambulance and Stretcher Party Depots to a suitable site where a building could be erected and parking facilities provided.

We desire to record that the plans for the adaptation of this depot were agreed by the Middlesex County Council and the Ministry of Health.

2. Clitterhouse Farm—Ambulance and Stretcher Party Depot:

(i) We are of opinion that the ventilation is unsatisfactory; that attention should be given to the question of ventilation and the

2. We desire to record our satisfaction with the orderly and well organised condition in which this depot was found during our inspection.

CRITICISMS.	COMMENDATIONS.
<p>provision of necessary heating in the men's rest room; and that an opening should be made in the fence to provide better access to the Women's lavatories.</p> <p>(ii) Additional rest room should be provided.</p> <p>(iii) Suitable covering should be provided for the concrete floor of the canteen.</p> <p>(iv) Further coat-hangers are required for hanging protective clothing.</p> <p>(v) It was ascertained that (at the time of our inspection) owing to the lack of necessary arrangements, two classes, each of 30 trainees, who had completed their training a month ago had not taken their examination.</p> <p>(vi) The kerbs at the entrance to the Dépôt and ambulance park should be splayed to provide better ingress and egress to minimise the dangers at present existing.</p> <p>(vii) We observed that the benches in the undressing sheds were not covered with impervious material and we recommend that the benches in the undressing sheds at this Dépôt and in all other Dépôts where this is not already provided, should be so covered.</p> <p>3. West Hendon First Aid Post:</p> <p>(i) Pools of water were found on the concrete floor outside the undressing shed. Attention should be given to this matter.</p> <p>(ii) There is insufficient room to enable stretchers to be taken into or out of the First Aid Post.</p> <p>(iii) No "showers" are provided (only a hose-pipe) and no overhead covering from the undressing sheds to the treatment room.</p>	<p>We are of opinion that the "showers" in the cleansing section are now quite satisfactory.</p>

CRITICISMS.

COMMENDATIONS.

(iv) No facilities are provided in the cleansing section for the segregation of sexes.

(v) Proper facilities are required for hanging the protective clothing.

(vi) In the absence, through illness, of the Sister-in-Charge, Miss Drakas was on temporary duty. In this connection it is understood that Miss Drakas is "on call" when not at the Post, but we consider that although she can be got into touch with over the telephone, she resides too far away from the Post to enable her to get there in reasonable time in the event of an air raid taking place, and the Post might therefore, be left without proper supervision.

General Conclusion.—We recommend that every effort be made to expedite the completion of the new First Aid Post at the Isolation Hospital in order that the use of this First Aid Post, which in our opinion is entirely unsatisfactory, can be discontinued.

4. West Hendon Swimming Pool—Combined Dépôt:

We regard this Dépôt as entirely unsatisfactory both from the point of view of accommodation and control.

5. Hendon Way—Rescue, Decontamination and Repair Dépôt:

(i) We observed that there were not sufficient facilities provided for drying protective clothing.

5. During our inspection we gave an order for a test turn-out in full protective clothing, and a complete turn-out of all parties stationed at the dépôt at the time of our inspection was effected in 13 minutes, which, we consider satisfactory.

CRITICISMS.

(ii) It was observed that a gong is used to warn the squads to "stand-to." We do not consider the gong sufficiently effective and are of opinion that an alarm-bell should be provided inside the men's quarters.

6. Mill Hill Swimming Pool—Combined Dépôt:

(a) Sub-Report Centre:

Ventilation and heating require attention. Higher chairs should be provided immediately for the telephonists.

(b) Rescue and Decontamination Section:

Immediate steps should be taken to prevent pilfering of petrol from the tanks of vehicles.

(c) Ambulance Section:

Cars for sitting cases should be put in order before delivery to the dépôt.

Vehicles Generally.—A senior chauffeur-mechanic in charge of vehicles should be appointed.

Staff.—Consideration should be given to the position of the Dépôt Commanders in relation to the leaders of other services.

7. Public Shelters:

We desire to call serious attention to the grave delay in the provision of the requisite number of public shelters. We understand, however, that difficulty has been experienced in obtaining sanction for the expenditure and approval of the sites.

COMMENDATIONS.

On Thursday, the 26th October, on our instructions, a test "turn-out" call was put through to this Dépôt from the Town Hall at shortly before 10 p.m. and a complete Light Rescue Squad, fully clothed and equipped, arrived at the Town Hall 16½ minutes after the call was put through. We considered the "turn-out" to be eminently satisfactory.

We wish to place on record our conclusion that this Dépôt is well organised and controlled and to express particular satisfaction with the de-contamination arrangements.

6. (a) We were greatly impressed with the efficiency of the Report Centre Staff as a result of a practice test which was carried out on our instructions.

PART II.

SERVICES INSPECTED BY THE COMMITTEE BUT NOT INSPECTED BY CAPTAIN MATHESON.

CRITICISMS.	COMMENDATIONS.
<p>(A) Mill Hill, Hartley Avenue First Aid Post:</p> <ul style="list-style-type: none">(i) The arrangements for cleansing at this First Aid Post are deplorable and there is no provision for the cleansing of male casualties.(ii) The storage accommodation for protective clothing is unsatisfactory. <p>(B) Mobile Unit:</p> <p>We consider that a suitable form of interior heating should be provided for the mobile unit.</p> <p>(C) Central Hendon First Aid Post:</p> <ul style="list-style-type: none">(i) The cleansing arrangements at this post are unsatisfactory.(ii) The question of ventilation requires attention and the faulight should be made movable.(iii) Only one man is on duty on alternate days.(iv) The protective clothing should be properly suspended.(v) More volunteers are required to man the post. <p>(D) Hendon County School—Ambulance and Stretcher Party Depot:</p> <ul style="list-style-type: none">(i) No facilities are provided for hanging protective clothing.(ii) The gymnasium, which is used for sleeping quarters for men, should be blacked out.	<p>(A) On our inspection of this First Aid Post we were pleased to be assured of the harmonious working of the Post between the members of the British Red Cross Society and the St. John Ambulance Association.</p> <p>(D) This depot is generally satisfactory.</p> <p>The "turn-out" of the ambulance personnel which was carried out at our request, was very smart, and we desire to pay tribute to the excellent team spirit existing at this Depot.</p>

CRITICISMS.

COMMENDATIONS.

(E) Christ Church Hall—Rest Quarters for Nurses:

We observed that the sink in the kitchen was stopped up and that there was no plug in the lavatory basin.

The water supply in the W.C. was defective and no light provided.

These matters require attention.

(F) John Groom's Grippage—Ambulance and Stretcher Party Depôt:

(i) We ascertained during our inspection that the Deputy Depôt Commander would be relinquishing duty the following day but that no substitute had been appointed.

(ii) Small size respirators are required for the women personnel.

(iii) While adequate facilities for ventilation exist these were not used in the men's quarters.

(C) Redhill County Hospital—Ambulance and Stretcher Party Depôt:

(i) In the ambulance depôt, the sleeping accommodation is inadequate and an endeavour should be made to obtain further use of a part of the Old Men's Quarters to provide additional sleeping accommodation.

(ii) Further blankets are urgently required for the ambulances. We were given to understand that these have been on order for two or three weeks.

(iii) There was an air of untidiness generally.

(iv) Supervision of the female personnel by a Lady Commandant of either the British Red Cross Society or the St. John Ambulance Association would appear to be essential.

CRITICISMS.

- (v) We were unable to obtain access to the First Aid Post which, we were told, would not be staffed by voluntary personnel.
- (vi) We were very surprised to find there was no proper decontamination provision and we consider that the County Council, as the Scheme Making Authority, should have provided thoroughly adequate cleansing facilities which could have served as a model for the rest of the district.

(H) West Hendon—York Park Shelters:

We desire to draw attention to the fact that rain gets into the trenches at the emergency exits. We are further of opinion that retaining concrete walls should be provided at the entrance to the trenches.

(I) Colindale Hospital, First Aid Post:

- (i) The Rest Room at this First Aid Post is very inadequate.
- (ii) Telephone facilities are required.
- (iii) There is an absence of "showers."

(J) Hendon Isolation Hospital—Casualty Clearing Station:

It is essential that sheds should be provided for cleansing purposes for both men and women.

(K) A.R.P. Headquarters, Ravensfield:

The user of the office premises is in need of re-organisation.

It is our view that the Controller's office should not be used for sleeping accommodation. Other rooms could be made available for that purpose.

The stores are in a chaotic condition. No entry has been made in the stockbook since September 2nd, 1939, and adequate arrangements are necessary.

In view of the fact that the Chief Warden's Office is the Field Headquarters of an extensive organisation, the map was not adequate for its purpose.

COMMENDATIONS.

- (H) We were pleased to find that, in spite of the very wet weather, the trenches in York Park were highly satisfactory.

- (I) The test to "Action Stations" carried out during our inspection was performed in an efficient manner.

- (J) We express very great appreciation of the arrangements made at this hospital and during our visit we were pleased to observe many desirable innovations carried out by the Medical Staff in conjunction with the Borough Engineer's Department.

7.—AMBULANCES:

The new ambulances show a very marked improvement on those originally provided, but We RECOMMEND—

- (a) That on all ambulances the exhaust pipe should be continued up to the top of the side of the vehicle to prevent fumes penetrating.
- (b) Reflectors, internal lighting and seating accommodation for the attendants—where lacking—should be fitted.
- (c) All ambulances should be fitted with metal flooring.

Attention is also drawn to the damp condition of the interior of certain of the ambulances.

8.—WARDENS' ORGANISATION:

We interviewed the Chief Warden (Captain Petrie) who raised certain matters of detail with regard to the Wardens' Organisation, which could not be dealt with by us, but require attention at an early date.

9.—DISMISSAL OF PERSONNEL:

We think it undesirable that subordinate officers in Air Raid Precautions, paid or unpaid, should be empowered to dismiss personnel (paid or unpaid), and We RECOMMEND—

THAT in future such action be taken by the Controller or other Chief Officers; who will have the benefit of the advice of the subordinate officers.

10.—EMERGENCY COMMITTEE—PROCEEDINGS:

On the instructions of the Committee the Town Clerk reported—as to the recording of the proceedings of the Emergency Committee—as follows:—

“The Emergency Committee are to issue instructions to the Controller who is to give the necessary orders. He is also the officer to whom the Government should give their instructions. In the words of Sir Ernest Gowers, one of the Commissioners for the London Civil Defence Region ‘the Controller not only reports to the Committee and then passes instructions to the Chief Officers, but he is an Executive Officer... He has the responsibility and decisions must not be carried through other sources.’

We have been told that A.R.P. is an integral part of Local Government. I consider that the instructions of all Local Government Committees should be issued through the Town Clerk as the mouthpiece of the Council. This cannot, however, prevail where an outside Controller is endowed with power to convey the decisions of the Committee and instructions to the Chief Officers and, in the existing circumstances, the only practicable method is for the Controller to carry out the whole of the organisation and administration, record the decisions of his Committee and obtain all necessary approval and consents.

It is essential to avoid dual control.

Under existing conditions A.R.P. must remain divorced from the ordinary functions of Local Government.”

As the matters stand at present a further difficulty arises in relation to the Auxiliary Fire Service.

It will be remembered that the Controller does not control or accept responsibility for that service. It would appear therefore that matters relating to the Auxiliary Fire Service should revert to the Works and Fire Brigade Committee, which has control of the permanent brigade.

The Committee are in accord with the views expressed in the Report.

11.—RELIEFS FOR RESPONSIBLE OFFICERS:

Proper reliefs must without delay be provided for all responsible Officers of the Air Raid Precautions Services if the efficiency of the organisation is to be maintained.

12.—MESSENGERS—AIR FORCE CADETS:

The Air Force Cadets at the Main Control Centre are employed 12 hours a day for seven days a week. The age of these boys is between 16 and 18 and we are of opinion that some drastic revision of this arrangement is necessary immediately.

13.—MAP AND CHART:

We have caused to be prepared and displayed in the Council Chamber for the information of Members, a Chart and Map shewing the whole of the Air Raid Precautions Services.

14.—GENERAL:

We are pleased to note the very definite progress in all Air Raid Precautions Services during the past month.

15.—Other conclusions and recommendations are in MS.

R. A. B. TEARE (Chairman).	} Members of the Committee.
W. M. MAUGHAN	
G. R. RICHARDSON	
T. K. BRIDGE	
G. J. PRYKE	
T. J. SCOTT	

3rd November, 1939.

Discussion ensued on consideration of the report.

AMENDMENT moved by Councillor Pinkney, seconded by Councillor Curton:—

THAT paragraph 15 of the report be amended to the intent that the manuscript items be taken in Open Council.

The amendment, on submission, was declared **lost**, whereupon Councillor Pinkney requested the Council to take note of his resignation from membership of the Emergency Committee as from this evening.

FURTHER AMENDMENT moved by Councillor Curton, seconded by Councillor Arter:—

THAT paragraph 3 of the items recorded in manuscript be considered in Open Council this evening.

The further amendment, on submission, was declared **carried**.

Discussion thereupon ensued upon the following paragraph of the manuscript entries:—

3. We acknowledge the unremitting and sincere labours of the Emergency Committee since the outbreak of War. Their work has, however, been seriously hindered by a lack of unanimity. It is our considered opinion that better team-work, tactful co-ordination, and the exercise of business acumen, would have prevented many of the defects and greatly improved the Air Raid Precautions Organisation throughout the Borough.

ADOPTION OF REPORT: Before moving the adoption of the report, the Chairman of the Special (A.R.P.—Inquiry) Committee (Alderman Teare) expressed on behalf of the Committee their appreciation of the assistance rendered them by the Town Clerk, and also by Mr. Blizard, who had cheerfully responded to the very heavy demands upon him.

Motion moved by Alderman Teare, seconded by Alderman Maughan, and
 382.—RESOLVED—That the report of the Special (Air Raid Precautions—Inquiry) Committee be approved and adopted, and the Emergency Committee requested to implement as soon as possible the conclusions and recommendations therein contained.

SPECIAL (FIRE BRIGADE—INQUIRY) COMMITTEE:

Councillor Shakespeare informed the Council that at the first meeting of the Special (Fire Brigade—Inquiry) Committee he was appointed to preside over their deliberations, which he did until Thursday last, but that since then Service duties had precluded his attendance and Councillor Hignett had taken the Chair. He therefore asked the Council to permit Councillor Hignett to present the report. The Council indicated their assent to this course.

Motion moved by Councillor Hignett, seconded by Alderman Copestake, and
 383.—RESOLVED—That the following report be received:—

INTERIM REPORT
 of the
SPECIAL (FIRE BRIGADE—INQUIRY) COMMITTEE.

COMMITTEE:

Councillor W. H. N. Shakespeare, M.C., A.F.C., J.P. (Chairman).
 .. E. J. Cox.
 .. G. H. Hignett.
 .. T. Pugh.
 .. C. F. Windust.

Introduction.

As stated in the Mayor's official announcement the Committee was appointed (27th October) with the following terms of reference:—

"To enquire into the general condition of the Fire Brigade Services of the Borough."

Our first meeting was held on the day of appointment, since which date we have met daily either at the Town Hall or on visits of inspection to the Auxiliary Fire Stations, and it is considerations arising out of the latter visits which reveal the necessity for this interim report.

It must be understood that to fully discharge our reference it will require extensive research and enquiry, and in these circumstances it will not, it is felt, be possible to bring our proceedings to a conclusion and to report on other issues, if any, until a later date. It has been the subject of discussion amongst us, and a division of opinion exists as to whether the extremely wide terms of reference were intended when the proposal for the appointment of the Committee was made, and we would be glad if a direction can be given as to the application of the reference to the regular Fire Brigade.

REPORT—AUXILIARY FIRE STATIONS.

The Auxiliary Stations included in the Council's Emergency Fire Brigade Scheme under the Air Raid Precautions Act, 1937 [Section 1 (3)] comprises the following premises:—

Section No.

- 1 Station Garage, Station Road, Edgware.
- 2 Mill Hill Fire Station, Hartley Avenue, N.W. 7.
- 3 Horrocks Garage, East Road, Burnt Oak.
- 4 Wentworth Hall Garage, The Ridgeway, N.W. 7.
- 5 Lymph Establishment, Colindale Avenue, N.W. 9.
- 6 Hills Garage, Finchley Lane, N.W. 4 (temporarily at Central Fire Station).
- 7 St. Peter's Hall, Cricklewood Lane.
- 8 Saunders Garage, Finchley Road, N.W. 11.

All Auxiliary Fire Stations (generally, occupied on the 1st September) have been inspected and the conditions investigated. We were particularly concerned to find that in some cases the living arrangements (sleeping and messing) were in a very unsatisfactory condition, which had been accentuated by the recent cold weather. In fact we regarded the matter of sufficient importance to make immediate representations to the Emergency Committee on the 31st October with a view to the early alleviation of the apparent discomforts which existed.

It is understood that plans for the adaptation of the premises for the purpose of the Fire Services were prepared and had been before the Emergency Committee, but on the issue of the Home Office Circular No. 70/1939 on the 29th September it became necessary for amendments and additions to be made to bring the buildings into line with the requirements laid down for the organisation of Auxiliary Fire Stations for continued occupation.

The plans have been the subject of discussion with the Home Office, and the Borough Surveyor has reported to us and to the Emergency Committee, that following a visit of Technical Officers of the Department the proposals shown on the plans are regarded as a minimum for the purpose, and as there did not appear to be any prospect of finding more suitable premises in the required areas they would recommend the Home Office to approve the plans and estimates.

With this information at hand we have thought it expedient to represent to the Emergency Committee the necessity for the immediate execution of certain works which, if carried out separately, might have had the effect of increasing the estimated costs of the complete schemes as shown on the plans. In these circumstances it was suggested that the improvements in their entirety at certain Stations should be immediately carried out without waiting for the formal approval of the Home Office.

We are pleased to record the Emergency Committee's concurrence in the proposals submitted to them, and formally place on record below a list of the contemplated provisions:—

Works per the Borough Surveyor's Plans and Estimates:—

Section No.		Estimated Cost.
		£
1	STATION ROAD GARAGE, Edgware	495
3	HORROCKS GARAGE, East Road, Burnt Oak	550
4	WENTWORTH HALL GARAGE, The Ridgeway, N.W. 7	400

All Sections.—6 Canvas Chairs to all Stations.

Proposals modifying Plans and Estimates:—

Section No.

8 SAUNDERS GARAGE, Finchley Road, N.W. 11.

Vacation of King Freemans Premises and the substitution of St. Albans Hall, West Heath Drive, for sleeping and messing accommodation.

[This will have the effect of saving some £350 on adaptation of the building to be vacated.]

Additional:—

Section No.

6 CENTRAL FIRE STATION, N.W. 4 100

The immediate erection of a hut to serve as storage accommodation for equipment, and thus release two rooms at "Fenella" to be utilised for sleeping accommodation for the Members of the Auxiliary Fire Service.

2 MILL HILL 100

Pathway, Hartley Avenue to messroom and extension of messing accommodation.

 1645

CONCLUSION AND RECOMMENDATION.

At one of the Auxiliary Fire Stations we were informed of the resignations of no less than eight members of the Service and we gathered that conditions of living were contributory factors in the resignations of at least four. The Emergency Committee appear to have comprehensive schemes in the Borough Surveyor's plans for all necessary adaptation and improvement of buildings concerned in the Emergency Fire Brigade Scheme and the acceleration of the works referred to above will result in a greater degree of contentment at the Auxiliary Fire Stations where remedial measures are most pressing.

We strongly urge the Council to confirm the action which we have taken in the matter, and to endorse the authority given by the Emergency Committee to proceed with works in anticipation of the sanction from the Home Office.

With regard to the terms of reference, perhaps the Council will give a direction as to whether our enquiries are to extend in all respects to the regular Fire Brigade.

Our Chairman, Councillor W. H. N. Shakespeare, has unfortunately been precluded from sitting with us since Wednesday owing to his Service duties, and whilst he is aware of the presentation of this report he has not had the opportunity of knowing its full text, hence the reason that his signature is not appended hereto.

(Signed) G. H. HIGNETT.
 TOM PUGH.
 EDWARD J. COX.
 CHAS. F. WINDUST.

2nd November, 1939.

REPORT

Moved by Councillor Hignett, seconded by Councillor Windust:—

THAT the report of the Committee be approved and adopted, and that the terms of reference to the Special (Fire Brigade—Inquiry) Committee be amended to read:—

“ To enquire into the general condition of the Auxiliary Fire Brigade Service of the Borough and into the relationship of the personnel of the Regular Fire Brigade to that Service, and to report thereon.”

After discussion, the motion was submitted and declared **carried**.

384.—Accordingly **RESOLVED**—**That the report of the Committee be approved and adopted, and that the terms of reference to the Special (Fire Brigade—Inquiry) Committee be amended to read:—**

“ To enquire into the general condition of the Auxiliary Fire Brigade Service of the Borough and into the relationship of the personnel of the Regular Fire Brigade to that Service, and to report thereon.”

REPORT OF EMERGENCY COMMITTEE:

Councillor Arter asked that a lengthy report of the Emergency Committee should be circulated to the members and considered by the Council this evening. The Mayor ruled that as the report did not appear on the agenda for the meeting it could not be considered, but that arrangements would be made to enable the report to be considered at the Annual Meeting of the Council on the 9th instant.

The meeting terminated at 7.40 p.m.

Adams
Mayor.

A
B
C
D
E
F
G
H
I
J
K
L
M
N
O
P
Q
R
S
T
U
V
W
X
Y
Z

NAME	COUNCIL		Hi.	E.P.A.	P.H.& M.S.	Bldgs	Hsg.	Li. & Pen.
	Spec. Statutory & Ord.	in Cttee	Cttee	Cttee	Cttee	Cttee	Cttee	Cttee
	P. A.	P. A.	P. A.	P. A.	P. A.	P. A.	P. A.	P. A.
✓ COX E.J.	20 15	6 4		7 6			8 5	9 5
✓ CURTON A.W.	20 18	6 5	7 7					
✓ GILPIN F.W.	20 15	6 4			8 7		8 7	9 8
✓ GREVILLE A.W.	20 20	6 5	7 7					
✓ GRIFFITHS J.	20 13	6 2	7 6			8 4		
✓ HICKS W.A.	20 16	6 5		7 6		8 6		
✓ HIGNETT G.H.	20 20	6 6			8 8	8 8		
✓ HIRSHFIELD L.	20 15	6 4			8 6	8 5		
✓ LIGHTFOOT P.	20 19	6 5			8 8		8 8	9 9
✓ NAAR A.A.	20 20	6 6	7 6					
✓ <i>True</i> PARVIN MRS F.E.	20 20	6 6		7 7				
✓ PINKNEY C.	20 17	6 6			8 7		8 6	9
✓ PRYKE G.J.	18 17	5 4	6 6				6 6	7
✓ PUGH T.	20 20	6 6		7 6		8 6		
✓ RICHARDSON G.R.	20 20	6 5			8 7		8 7	9
✓ RODWAY J.H.	20 17	6 5		7 7				
✓ SCOTT T.J.	20 19	6 4			8 8		8 7	9
✓ SHAKESPEARE W.H.N.	20 17	6 5		7 6		8 8		
✓ SMALL H.P.	20 18	6 6			8 6	8 8		
✓ THOMAS MRS.M.	20 10	6 3			8 2		8 3	9
✓ WINDUST C.F.	20 19	6 6	7 7					

sg.

ttee

A.

5

7

8

6

6

7

7

9

BOROUGH OF H

MEMBERS ATTENDANCE
1938/1939.

NAME	COUNCIL		Hi.	E.P.A.	P.H.& M.S.	Bldgs.	Hsg.	Li.& Peris.	W.& F. B.
	Spec-ial. Statu-tory & Ordin-ary.	in Cttee	Cttee.	Cttee.	Cttee	Cttee.	Cttee.	Cttee.	Cttee
✓ POTTER H.G. (MAYOR)	P. A. 20.20.	P. A. 6 6	P. A. 7 4		P. A.				P. A. 9 7
✓ CLEMENS W.R.	20.16.	6 2			8 5	8 6			
✓ COPESTAKE J.J.	20 19	6 4	7 7			8 7			
✓ EGAN S.H.	20 16	6 5		7 5		8 6			
✓ FLOWERS B.	20 13	6 5			8 6	8 5			
✓ MAUGHAN W.M.	20 19	6 6			8 8		8 8	9 8	
✓ REYNOLDS A.J.	20 15	6 5	7 5						9 8
✓ RICE F.C.	20 15	6 4	7 5						9 7
✓ TEARE R.A.B.	20 17	6 4		7 7			8 8	9 9	
✓ ARTER E.	20 18	6 6	7 6			8 5			
✓ BATE F.H.	20 20	6 4		7 7		8 8			
BRIDGE T.K.	6 6	2 2		2 2			2 2	2 2	
✓ COLLINS F.J.	20 19	6 6		7 7					9 8
✓ CONNELL H.	20 15	6 2	7 6						9 9

1
2
3
4
5
6
7
8
9
10
11
12
13
14
15
16
17
18
19
20
21
22
23
24
25
26
27
28
29
30
31
32
33
34
35
36
37
38
39
40
41
42
43
44
45
46
47
48
49
50
51
52
53
54
55
56
57
58
59
60
61
62
63
64
65
66
67
68
69
70
71
72
73
74
75
76
77
78
79
80
81
82
83
84
85
86
87
88
89
90
91
92
93
94
95
96
97
98
99
100

W.&.F.
B.
Cttee

	P.	A.
	9	4
	9	9
	9	9
	9	7
6		
7		
7		
	9	8
3		
3		
	9	8
		8

W.&F. B. Cttee	Rating Cttee	F.&G.P Cttee	AIR RAID PRECAU- TIONS CTTEE.			School Li.Sub Cttee	Books Selec- tion Sub- Cttee	TOTAL
			Ordin- ary.	Spec.	Emer- gency.			
P. A.	P. A.	P. A.	P. A.	P. A.	P. A.	P. A.	P. A.	P. A.
	8 3							58 38
9 4	8 7	9 8	13 10	6 6	22 22			100 87
		9 6						60 47
9 9								42 41
			13 8					54 33
	8 4		13 10					62 47
		9 9	13 12					64 63
		9 9	13 8					64 47
		9 9				2 2	6 6	68 66
9 9		9 9	13 12	6 6				70 68
9 7								42 40
6		7 7	12 9	6 5	22 22			98 85
7								42 40
								41 38
7		7 7				2 1	6 5	66 59
9 8								42 37
8		9 8	13 8	4 4		2 1	6 4	85 71
		9 7	13 8					63 51
	8 7	7 5						57 50
3							6 1	57 22
9 8	8 7		13 13					63 60